

**United States Court of Appeals  
for the Federal Circuit**

---

**3M INNOVATIVE PROPERTIES COMPANY AND 3M  
COMPANY,**  
*Plaintiffs-Appellants,*

v.

**TREDEGAR CORPORATION AND TREDEGAR FILM  
PRODUCTS CORPORATION,**  
*Defendants-Appellees.*

---

2012-1241

---

Appeal from the United States District Court for the  
District of Minnesota in No. 09-CV-3335, Judge Donovan  
W. Frank.

---

Decided: August 6, 2013

---

JONATHAN F. COHN, Sidley Austin LLP, of Washing-  
ton, DC, argued for plaintiffs-appellants. With him on the  
brief were CARTER G. PHILLIPS and BRIAN P. MORRISSEY.

CHARLES K. VERHOEVEN, Quinn Emanuel Urquhart &  
Sullivan LLP, of San Francisco, California, argued for  
defendants-appellees. With him on the brief were  
CHRISTOPHER E. STRETCH, EMILY C. O'BRIEN and AARON J.  
BERGSTROM. Of counsel on the brief was KURT J.  
NIEDERLUECKE, Fredrickson & Byron, P.A., of Minneap-  
olis, Minnesota.

Before O'MALLEY, PLAGER, and REYNA, *Circuit Judges*.

Opinion for the court filed by *Circuit Judge* REYNA.

Concurring opinion filed by *Circuit Judge* PLAGER.

Concurring-in-part and dissenting-in-part opinion filed by  
*Circuit Judge* O'MALLEY.

REYNA, *Circuit Judge*.

This appeal deals with claim construction disputes arising out of 3M Innovative Properties Company and 3M Company's (collectively, "3M") allegations of patent infringement brought against Tredegar Corporation and Tredegar Film Products Corporation (collectively, "Tredegar") in the United States District Court for the District of Minnesota ("district court"). 3M competes in the elastomeric laminate industry with Tredegar. 3M is a global manufacturing company that sells laminate products such as diapers. Tredegar is a supplier of breathable and nonwoven film laminates for personal care products, including baby diapers, training pants, and adult incontinence products.

The district court construed claim terms in four asserted patents. After claim construction, the parties stipulated to noninfringement. 3M appeals the district court's construction for four of the thirty disputed claim terms or groups of terms. We *affirm* the appropriate scope of the claim terms "continuous contact" and "continuous microtextured skin layer over substantially the entire laminate," but clarify the appropriate scope of those claim terms. We *reverse* the district court's claim constructions relating to the terms grouped as "preferential activation zone" and the term "ribbon." Because the district court erroneously limited certain claim terms in a manner that is inconsistent with the intrinsic disclosures, we provide the appropriate constructions, *vacate* those

constructions that are inconsistent with the analysis herein, and *remand* for further proceedings.

## I. BACKGROUND

### A. Technical Overview

The patents-in-suit relate to multi-layer elastomeric laminates found in the body-hugging areas of products such as the waistband or side tabs of disposable diapers or adult incontinence products. The claims disclose stretchable films or laminates that, once affixed to the diaper, allow the product to expand to fit around the person wearing them with the laminate stabilizing to recover its shape once stretching is complete.

The elastomeric nature of the laminate is discussed in all four patents.<sup>1</sup> United States Patent Nos. 5,501,679 (“the ’679 Patent”) and 5,691,034 (“the ’034 Patent”)—the Krueger Patents—share a largely identical written description and are directed to laminates with “continuous” microtexturing over the laminate’s skin layer. See ’034 Patent col. 28 ll. 40-45; ’679 Patent col. 3 ll. 15-45. United States Patent Nos. 5,468,428 (“the ’428 Patent”) and 5,344,691 (“the ’691 Patent”)—the Hanschen Patents—are

---

<sup>1</sup> All of the patents in suit name more than one inventor. When discussing the prosecution history, we collectively refer to the multiple inventors as “the applicant.” Consistent with the manner in which the parties presented arguments, we divide the asserted patents into two groups and discuss them accordingly. We refer to U.S. Patent Nos. 5,501,679 and 5,691,034 by reference to lead inventor, Dennis L. Krueger (“the Krueger Patents”). We refer to U.S. Patent Nos. 5,468,428 and 5,344,691 by reference to lead inventor Thomas P. Hanschen (“the Hanschen Patents”). The two Krueger Patents and the two Hanschen Patents share nearly identical written descriptions.

directed to laminates in which the elastic or stretching portions of the skin layer are limited to selected areas identified as “preferential activation zones,” with the adjacent regions of the skin layer remaining inelastic. *See* '691 Patent col. 8 ll. 6-59.

The internal core and surrounding skin layers are central to the claimed inventions. *E.g.*, '679 Patent col. 4 ll. 46-51, col. 15 ll. 15-17. One or more inelastic skin layers are outside an elastic or stretchable core layer. The flanking skin layers protect the elastomers in the core from degrading when exposed to oxygen. Depicted below is a scanning electron micrograph (100x) of the core and skin layers as seen in the written description of the Hanschen Patents. *See* '679 Patent col. 4 ll. 15-17.

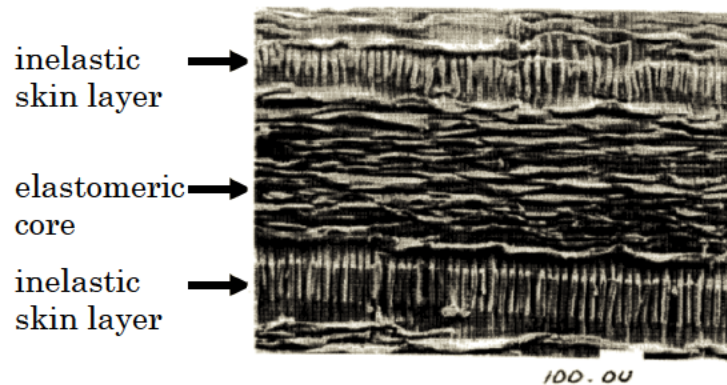

*Fig. 16*

In the absence of stretching, the core and skin layers are intact. But, when the laminate is stretched, folds form where the skin meets the core and the folding alters the surface texture. *See* '034 Patent col. 11 ll. 50 to col. 12 l. 4 (describing the folds as “buckled” or as appearing “worm-like” in character). The folds in the skin give rise to a microtextured surface. A side-by-side comparison of Figures 1 and 2, cross-sectional laminate drawings, illustrates the changes that occur during stretching. In Figure 1 the core and skin layers are tightly bound, while

in Figure 2, stretching has resulted in microtexturing of the laminate, seen as folds between the skin and core layers:

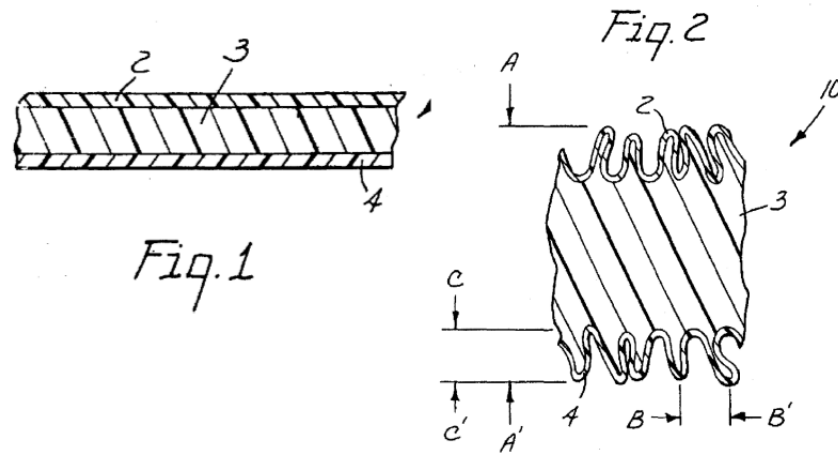

'034 Patent col. 3 ll. 42-46, col. 10 ll. 62-65. The microtexturing that occurs upon stretching provides elasticity, durability, and gives the expanded garment a soft feel. *Id.* at col. 11 ll. 35-42, col. 13 ll. 1-8, col. 13 ll. 22-30.

Both the Krueger and Hanschen Patents address problems resulting from the inflexibility of the materials used in the prior art to manufacture a diaper waistband or the protective back sheet or top sheet of a diaper. *See, e.g.,* '034 Patent col. 3 ll. 1-8; *see also* '691 Patent col. 2 ll. 12-14 ("Problems with these elastomeric films include the difficulties inherent in applying a stretched elastic member to a flexible substrate such as a disposable diaper."). For example, the Krueger Patent disclosure explains that the lack of flexibility in earlier laminates results in an uncomfortable stiffness that can cause the material to "bite" or "grab" the wearer of the diaper. '679 Patent col. 3 ll. 6-11.

Additional problems were discussed with the PTO examiner during prosecution. In the application that later issued as the '679 Patent, the examiner considered U.S.

Patent No. 4,880,682 (“Hazelton”) and U.S. Patent No. 5,057,097 (“Gesp”) and noted that “neither Gesp nor Hazelton et al. disclose films capable of recovering slowly over time at ambient conditions or capable of substantial heat activated recovery” as claimed in the ’679 Patent application. J.A. 1257. In these prior art laminates, the outer skin layers deformed when stretched; the deformation impeding recovery because there was only intermittent contact between the skin and the core. *E.g.* J.A. 1526; *see also* J.A. 1257. 3M maintains that separated skin and core layers exposed the core to oxidation, thereby decreasing the effectiveness of earlier films.

The Krueger Patents overcome some of the problems associated with robust stretching by allowing the laminate to recover following deformation. The “continuous contact” between the layers allows for recovery from deformation because the microtexturing—*i.e.* folds in the skin layer—allows the laminate to withstand the compromising effects of the skin and core being pulled apart. Claim 1 in the ’034 Patent recites the arrangement of the layers:

1. An elastomeric laminate consisting essentially of at least one elastomeric layer and at least one continuous microtextured skin layer over substantially the entire laminate wherein:
  - (a) the microtexture on said skin layer is formed by stretching an untextured laminate past the deformation limit of at least one untextured skin layer and allowing the stretched laminate to elastically recover over the entire region stretched and
  - (b) said at least one elastomeric layer and said at least one continuous microtextured skin layer are in substantially continuous contact.

’034 Patent col. 28 ll. 40-45. Claim 1 of the ’679 Patent provides additional detail as to the nature of the micro-

texturing found on the skin layer that is in “continuous contact” with the elastic core layer:

1. A garment comprising a body engaging area said body engaging area comprising an elastomeric laminate comprising at least one discrete elastomeric layer and at least two discrete continuous skin layers at least one of which is a microtextured permanently deformed polymeric layer wherein the materials forming the elastomeric layer and the materials forming the polymeric layer are selected such that said at least one elastomeric layer and said at least one microtextured skin layer are in continuous contact.

'679 Patent col. 28 l. 61 to col. 29 l. 2.

The Hanschen Patents depart from the Krueger Patents in that they teach a laminate with “preferential activation zones.” As explained in the '691 Patent disclosure, the laminates claimed in the Hanschen Patents “are capable of becoming microtextured at specified areas along the laminate length.” '691 Patent col. 3 ll. 11-13. The microtextured areas correspond to sections of the laminate that have been “activated from an inelastic to an elastomeric form.” *Id.* col. 3 ll. 13-15. The Hanschen Patents thus limit elasticity to specific areas claimed as “preferential activation zones.” Claim 1 of the '691 Patent is representative of the claims relating to “preferential activation zone.” Claim 1 states:

1. A multi-layer film laminate comprising at least one nonelastomeric skin film layer and at least one core film layer, the at least one skin film layer and the at least one core film layer together forming at least one preferential activation zone where the film laminate will preferentially elongate when stretched, wherein said at least one core film layer is substantially elastomeric, each of said core and skin layers being substantially coextensive and having relatively constant average thickness over

both the at least one preferential activation zone and an at least one adjacent non-preferential activation zone such that, for a given skin or core layer, the skin or core layer thickness in one zone will be substantially the same as the same skin or core layer thickness in all zones, said at least one skin film layer and/or at least one core film layer are provided such that when the multi-layer laminate is stretched said at least one preferential activation zone will preferentially elongate and can recover in said preferential activation zone to become an elastic zone, of said multi-layer film laminate, and adjacent multi-layer non-preferential activation zones will not preferentially elongate to provide substantially inelastic zones.

'691 Patent col. 36 ll. 41-63.

The claimed zone can be activated by conditions producing designated stretch ratios. The Hanschen Patents depart from the Krueger Patents in that those patents require a lower stretch ratio to effectuate stretching or activate the microtextured laminate. *See* '691 Patent col. 3 ll. 34-49. In particular, the Hanschen Patent disclosure teaches that when stress is applied to a localized region, there will be preferential elasticization of the specified zone. *See id.* col. 3 ll. 38-58, col. 10 l. 11 (identifying methods of “post formation stress localization” or “controlled localized stretching”).

### B. Prior Proceedings

3M, the assignee of the Krueger and Hanschen Patents, brought suit against Tredegar on November 23, 2009. 3M sought injunctive relief as well as compensatory damages for alleged willful infringement. In its Answer, Tredegar filed counterclaims seeking declarations that the asserted claims were not infringed and that the patents are invalid and/or unenforceable. After briefing, the district court held a claim construction hearing on September 6, 2011 and issued a fifty-five page opinion



construing thirty separate terms from the four patents.<sup>2</sup> See *3M Innovative Prop. Co. v. Tredegar Co.*, No. 09-3335, 2011 WL 6004023 (D. Minn. Nov. 30, 2011) (“*Markman Order*”). Following the claim construction rulings, the parties jointly stipulated to a finding of noninfringement and the district court entered final judgment so that 3M could appeal. J.A. 4–6. The district court entered final judgment pursuant to the parties’ joint stipulation without making any independent findings on the allegations of infringement. Accordingly, we express no opinion as to the infringement contentions which remain open for the parties and the district court to resolve on remand.

## II. DISCUSSION

Claim construction is a question of law that we review without deference. *Cybor Corp. v. FAS Techs., Inc.*, 138 F.3d 1448, 1455–56 (Fed. Cir. 1998) (en banc). To the extent possible, claim terms are given their ordinary and customary meaning, as they would be understood by one of ordinary skill in the art in question at the time of the invention. *Phillips v. AWH Corp.*, 415 F.3d 1303, 1312–13 (Fed. Cir. 2005) (en banc). Idiosyncratic language, highly technical terms, or terms coined by the inventor are best understood by reference to the specification. *Id.* at 1315–16. While we construe the claims in light of the specification, limitations discussed in the specification may not be read into the claims. *Intervet Inc. v. Merial Ltd.*, 617 F.3d 1282, 1287 (Fed. Cir. 2010); *Abbott Labs. v. Sandoz, Inc.*, 566 F.3d 1282, 1288 (Fed. Cir. 2009). Courts may rely on dictionary definitions when construing claim terms, so long as the dictionary definition does not contradict any definition found in or ascertained by a reading of the patent documents. See *Advanced Fiber Tech. (AFT) Trust v. J & L Fiber Servs., Inc.*, 674 F.3d

---

<sup>2</sup> Most of the district court’s constructions are not at issue in this appeal.

1365, 1374–75 (Fed. Cir. 2012) (internal citations omitted).

The meaning of the claim language is informed, as needed, by the prosecution history. *Pass & Seymour, Inc. v. Int’l Trade Com’n*, 617 F.3d 1319, 1327 (Fed. Cir. 2010) (quoting *Multiform Desiccants, Inc. v. Medzam, Ltd.*, 133 F.3d 1473, 1478 (Fed. Cir. 1998)); *Phillips*, 415 F.3d at 1315. This court does not rely on the prosecution history to construe the meaning of the claim to be narrower than it would otherwise be unless a patentee limited or surrendered claim scope through a clear and unmistakable disavowal. *Trading Tech. Int’l, Inc. v. eSpeed, Inc.*, 595 F.3d 1340, 1352 (Fed. Cir. 2010) (internal citations omitted); *Vitronics Corp. v. Conceptronic, Inc.*, 90 F.3d 1576, 1582–83 (Fed. Cir. 1996).

It is with an eye to these tenets of claim construction that we review the district court’s *Markman* Order pursuant to our jurisdiction under 28 U.S.C. § 1295(a)(1).

#### A. “Continuous Contact”

The terms “continuous contact” and “substantially continuous contact” appear in claims 1, 2, 4, 5, 7, and 8 of the ’679 Patent, claims 1, 2, 5, and 6 of the ’034 Patent, and claim 52 of the ’691 Patent. The parties agree that the two terms should be given an identical construction. *See Markman* Order at \*7, n.8. The district court construed the terms to mean “full surface contact” in reference to the contact occurring between the elastomeric core layer and the folds of the microtextured skin. *Id.* at \*8–10.

The parties’ dispute is directed to three Figures in the specification of the Krueger Patents, wherein each Figure shows a varied mode of physical contact between the microtextured skin and the elastomeric layers. Figures 22, 23, and 24 set forth three distinct spatial relationships between the skin and the core during stretching; the spatial relationships depicted in the three figures frame

the parties' competing understandings of the claim term's scope.

The '679 Patent describes an embodiment with the core and skin remaining in "full contact," whereby the core material fills the folds formed in the skin layers. '679 Patent col. 13 ll. 10-12. Figure 22, representative of the full contact mode, shows such a stretched laminate:

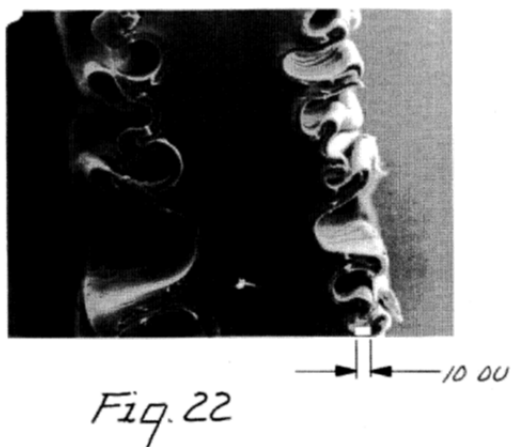

See *id.* col. 4 ll. 32-34. The parties agree that the full skin-to-core contact depicted in Figure 22 constitutes "continuous contact" as it is used in the claims.

The strained skin-to-core contact shown in Figure 23 is less than full contact. The Figure shows a stretched laminate with the folds of the skin pulling away from the core in a mode described as "cohesive failure."<sup>3</sup>

---

<sup>3</sup> All references to the cohesive failure mode in Figure 23 are exclusive to the right-hand side of the Figure as circled herein. At oral argument Tredegar understood 3M's position to also refer to the left-hand side of the Figure, but 3M conceded during briefing that the left-

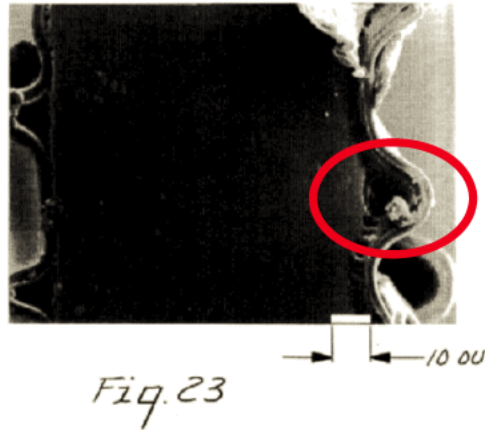

See '679 Patent col. 4 ll. 35-37. The specification describes this mode of contact as the elastomer filling the skin folds but cohesively failing under the folds. *Id.* at col. 13 ll. 14-16. As discussed in more detail below, 3M and Tredegar offer competing views as to whether a laminate presenting cohesive failure should be understood to have “continuous” skin-to-core contact.

Figure 24 shows only intermittent skin-to-core contact because the stretching has caused a lapse in the adhesion between the two layers. In this mode of contact, known as “intermittent contact” or “adhesive failure,” the extensive folding in the skin allows for only sporadic contact with the core.

---

hand side of Figure 23 “depicts adhesive failure akin to that observed in Figure 24.” Appellant Br. 16, n.9.

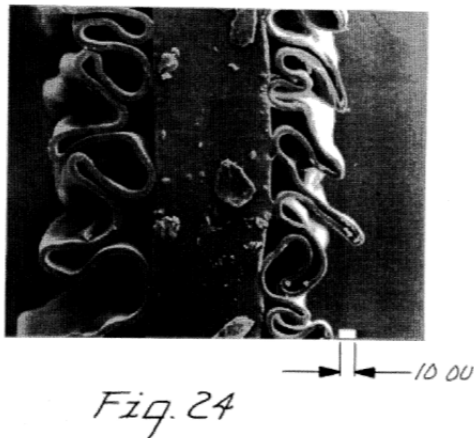

See '679 Patent col. 4 ll. 38-40. The intrinsic teachings differentiate between “adhesive failure” and “continuous contact,” with Figure 24 illustrating decreased skin-to-core contact. '679 Patent col. 6 ll. 46-49 (describing “adhesive failure of the skin to the core under the micro-textured folds with intermittent skin/core contact at the fold valleys”).

3M argues that the cohesive failure mode, like the full contact in Figure 22, is “continuous” or “substantially continuous contact” because the skin and core layers remain joined without interruption despite cracks pervading the core. The identified cracks within the core can be seen at the center-right of Figure 23 where, beneath the point of contact with the skin, the stretching has caused the core to pull apart. Pointing to this image of cohesive failure, 3M contends that because the cracks are within the core—and not between the core and skin layers—the skin-to-core contact is still “continuous.” 3M argues that there is no exclusion in the intrinsic disclosures that would preclude the term from being given its full effect, an effect which includes the cohesive failure in Figure 23.

Tredeggar counters by arguing that the cohesive failure mode is not a subset of “continuous contact” because, during prosecution, the applicant twice amended the claims to distinguish between Figures 22 and 23 so as to

limit itself to the full contact depicted in Figure 22. Tredegar, however, does not point to anything in the written description that would compel such a conclusion.

The district court adopted Tredegar's proposed construction of "full surface contact" after examining amendments made by the applicant during the prosecution of the claim issuing as claim 1 in the '679 Patent. In the *Markman* Order, the district court traced the original application, noting that it was amended on two separate occasions to distinguish the Hazelton prior art reference.<sup>4</sup> As originally drafted, the '679 Patent application had no limitation regarding the range of contact that could exist between the skin and core layers. *See* J.A. 1154. It was amended for a first time, adding the limitation "*substantially* continuous contact," to claim the interface between the skin and core. In submitting the amendment, the applicant noted that "substantially continuous contact" was depicted in Figures 22 and 23. J.A. 1268. This first amendment, however, was rejected as obvious in light of Hazelton. *Id.* In response, the claim was amended a second time by deleting the word "substantially" so that the limitation required "continuous contact" between the core and skin layers. J.A. 1278–80. The applicant did not provide statements illuminating why "substantially" was removed.

Tredegar argued, and the district court agreed, that by removing the word "substantially" from the first amended claim, the second amendment surrendered any skin-to-core contact that was not "full surface" contact.

---

<sup>4</sup> Hazelton disclosed a low gloss film made up of an elastomeric core and two inelastic outer skin layers. J.A. 1513 col.1 ll.57–60; *see also* J.A. 1268 ("Hazelton et al [sic] employ substantially the same genres of both core and covering materials as do applicants and the resultant films can be stretched to yield the same 'microtexturing' surface structure.").

*Markman* Order at \*9–10. The district court found that the second amendment to the claim disavowed embodiments depicting cohesive failure—*i.e.*, Figure 23. *See id.* at \*10. The district court limited its interpretation of “full surface contact” to the embodiment illustrated in Figure 22. *Id.*

### 1. Claims

We begin our analysis with the language of the claims. The term “continuous contact,” as used in the Krueger Patents, does not suggest whether the patentee intended the term to include the cohesive failure mode shown in Figure 23. Thus, while it is unclear whether the skin folds pulling away from the core qualify as remaining in “continuous contact,” there is no basis to suppose that the claim term applies only to the full contact mode shown in Figure 22. Indeed, claim 1 of the ’679 Patent merely states that the “elastomeric layer and [the] skin layer are in continuous contact.” ’679 Patent col. 29 ll. 1–2. In the absence of exclusionary language, the term’s ordinary meaning—read to give full effect to the claim language—captures situations in which the elastomeric layer undergoes cohesive failure because “continuous contact” requires nothing more than uninterrupted contact between the laminate’s skin and core layers. Regardless of whether the core has internal cracks, the applicant, in claiming his invention, did not suggest he sought to exclude cohesive contact. We therefore agree with 3M that the plain and ordinary meaning of the claim term supports a broad claim scope. *See TI Grp. Auto. Sys. (North Am.), Inc. v. VDO North Am., L.L.C.*, 375 F.3d 1126, 1138 (Fed. Cir. 2004) (explaining that absent other limiting circumstances, a patentee is entitled to the full breadth of claim scope supported by the words of the claims and the written description).

### 2. Written Description and Prosecution History

The written description and corresponding illustrations confirm that “continuous contact” includes the

cohesive failure mode of contact. The written description provides a concise recitation of two *variations* of “continuous contact” that align with the modes of contact depicted in Figures 22 and 23. *See* ’034 Patent col. 13 ll. 9-16. The disclosure first describes a situation in which “the core and skin remain in full contact,” *id.* at col. 13 ll. 4-6, and then characterizes instances of cohesive failure as “a variation” of this “continuous contact construction.” *Id.* at col. 13 ll. 8-11. The specification then distinguishes between cohesive failure and intermittent contact—as shown in Figure 24—emphasizing that the two modes of contact are distinct. By explaining that instances of cohesive failure are “a variation” of full contact and then distinguishing those variations from the intermittent contact or adhesive failure, the written description includes both full and cohesive contact within the meaning of “continuous contact.” *See* ’034 Patent col. 13 ll. 13-16 (describing the intermittent contact shown in Figure 24 as “an entirely different skin/core adhesion mode” from the “variations” of “continuous contact”).

Tredegar suggests that this reading of “continuous contact” is unsupported, but offers no competing written description reference that affirmatively requires narrowing the construction to include only Figure 22. The district court similarly failed to explain how the Krueger Patent disclosure requires excluding cohesive failure from the construction of “continuous contact.”

Tredegar relies heavily on amendments made during prosecution to assert that, in narrowing claim 1 of the ’679 Patent from “substantially continuous contact” to “continuous contact,” the applicant simultaneously limited itself to the skin-to-core contact of Figure 22. We have fully considered the narrowing amendments in the prosecution history, including the applicant’s stated reasons as to why the claims are patentable over Hazelton, and find Tredegar’s arguments unpersuasive. Ultimately, Tredegar fails to demonstrate how the amendments are tied to the cohesive failure characterized



in the issued patents as a “variation” of “continuous contact.” Indeed, cohesive failure—or a description thereof—is not mentioned in the applicant remarks surrounding either amendment. The district court found that the amendments constituted a disclaimer, but our precedent requires that, in order for prosecution disclaimer to attach, the disavowal must be both clear and unmistakable. *Lazare Kaplan Int’l., Inc. v. Photocopy Tech., Inc.*, 628 F.3d 1359, 1370 (Fed. Cir. 2010); *Omega Eng’g, Inc. v. Raytek Corp.*, 334 F.3d 1314, 1325–26 (Fed. Cir. 2003). Our cases also warn that, because the prosecution history represents an ongoing negotiation between the PTO and the inventor, “it often lacks the clarity of the specification and thus is less useful for claim construction purposes.” *Netcraft Corp. v. eBay, Inc.*, 549 F.3d 1394, 1401 (Fed. Cir. 2008) (quoting *Philips*, 415 F.3d at 1317).

We do not find a clear and unmistakable disclaimer of the cohesive contact depicted in Figure 23 in the prosecution history. It is apparent from the prosecution history that the applicant distinguished Hazelton, but there is no statement that amounts to a disavowal of cohesive failure. To the contrary, 3M presents a competing interpretation that the applicant eliminated the word “substantially” to more clearly recite that “continuous contact” was different from Hazelton because Hazelton disclosed only intermittent contact.<sup>5</sup> Such a reading of the prosecution history is consistent with the Krueger Patents’ written description. The patents refer to the full contact and cohesive failure modes of contact as variations of “continuous contact,” while explaining that the adhesive failure causing intermittent contact between the skin and core was something different. The December 13, 1994 remarks to the PTO

---

<sup>5</sup> Hazelton does not disclose continuous skin-to-core contact. See J.A. 1511–13. Hazelton instead discloses the kind of intermittent contact shown in Figure 24 of the Krueger Patents.

can be similarly read to clarify that the elimination of “substantially” was, at least in part, an effort to draw a line between the claimed “continuous contact” and the intermittent contact in Hazelton. J.A. 1280–81.

Given this reasonable, contrary reading of the prosecution history, we cannot say with certainty that the ’679 Patent was intended to limit “continuous contact” to the type of full skin-to-core contact depicted in Figure 22. Where an applicant’s statements are amenable to multiple reasonable interpretations, they cannot be deemed clear and unmistakable. *See Grober v. Mako Prods., Inc.*, 686 F.3d 1335, 1342 (Fed. Cir. 2012) (rejecting prosecution disclaimer arguments because the applicant’s ambiguous statements distinguishing from prior art did not focus on specific prior art features); *see also Abbott Labs.*, 566 F.3d at 1289. The district court erred when it concluded otherwise.

\* \* \*

Where, as here, a disavowal does not exist, the ordinary and customary meaning of the claim term will be given its full effect. In our view, the district court’s construction of “full surface contact” properly includes instances where the elastomeric layer fills the folds of the microtextured skin but cohesively fails under the folds. The district court’s claim construction of “full surface contact” is *affirmed* with the clarification that the definition includes the cohesive failure depicted in Figure 23.

#### B. “Continuous Microtextured Skin Layer”

The term “continuous microtextured skin layer over substantially the entire laminate” appears in claims 1, 2, 5, and 6 of the ’034 Patent. The district court concluded that the term should be read to require the microtexturing *and* the skin layer be “continuous” across “substantially the entire surface area of the laminate.” *Markman* Order at \*24. The district court qualified its construction, however, by acknowledging that the microtexturing is “substantially uniform over the elastomeric laminate

surface.” *Id.* at \*23 (citing ’034 Patent col. 11 ll. 35-37). We find the district court’s construction was consistent with the intrinsic evidence.

In essence, the parties dispute the extent of the microtexturing on the skin of the laminate, with each side interpreting the disputed claim language in a different light. The disputed words are:

1. An elastomeric laminate consisting essentially of at least one elastomeric layer and at least one *continuous microtextured skin layer over substantially the entire laminate* wherein:

’034 Patent col. 28 ll. 40-43 (emphasis added) (remainder of the claim omitted). 3M would read the foregoing claimed laminate to have “at least one microtextured region,” while Tredegar reads the same limitation as requiring the laminate, as a whole, to develop microtexturing. 3M argues that the district court improperly deviated from a plain reading of the claim term. It contends that the skin layer, not the microtexturing, must be “continuous” across the laminate because the adjective “continuous” only modifies the noun “skin layer.”<sup>6</sup> Tredegar contends that the district court’s construction is correct, and in particular, points to language in the written description that refers to a skin layer that is both continuous and microtextured over substantially the entire laminate. Close examination of the intrinsic and extrinsic references supports the middle path identified by the district court<sup>7</sup> in which a skin layer can have non-

---

<sup>6</sup> 3M maintains that the district court should have construed the claim term as “one unified skin layer over substantially the entire laminate having at least one microtextured region.”

<sup>7</sup> The district court indicates that it is adopting Tredegar’s proposed construction but the accompanying discussion is not precisely aligned with Tredegar’s narrow

microtextured areas, but the microtexturing encompasses “substantially the entire surface area of the laminate.” *See Markman Order* at \*24.

3M’s purported plain reading of the claim term applies the *The Chicago Manual of Style* in arguing that “continuous” is limited to modifying “skin layer” and cannot modify the entire phrase “microtextured skin layer.” We do not adopt 3M’s reliance on extrinsic evidence because we must first consider what a skilled artisan reading the claim would understand the limitation to mean. Here, the ’034 Patent provides a skilled artisan with substantial guidance in deciphering the extent of the microtexturing. The written description is unambiguous in teaching that the microtexturing is continuous, but not restricted to a single zone or region of the skin layer. The Patent specifically refers to “unique continuous microstructured surfaces,” ’034 Patent col. 12 l. 11, and particularly characterizes the microtexturing as being “substantially uniform” over the laminate surface. ’034 Patent col. 10 ll. 35-37.

When viewed contextually against the applicant’s description of the invention, the extent of the microtexturing is ascertainable. To qualify as “continuous,” the microtexturing need not be symmetrical or perfectly uniform across the entire surface of the skin layer. Rather, the ’034 Patent confirms that stretching impacts the surface structure: “The unique continuous microstructured surfaces of the invention can be altered and controlled by the proper choice of materials and processing parameters.” *Id.* at col. 12 ll. 11-13. A skilled artisan reading the

---

approach. *Markman Order* at \*23–24. Our interpretation of the claim limitation adopts the district court’s discussion of the written description references but, as discussed herein, we do not agree with the overly broad understanding set forth by 3M, nor do we agree with the restrictive interpretation set forth by Tredegar.

disclosure would understand the claimed “continuous microtextured skin layer over substantially the entire laminate” to be the same “unique continuous microtextured surfaces” in the written description, and she would further understand the microtexturing as “substantially uniform.” *See id.* at col. 10 ll. 35-37. By contrast, there is no discussion in the written description that minimizes the microtexturing to 3M’s suggested single region of the skin layer.

While it may be beneficial, for purposes of litigation, for 3M to argue that if the inventors had wished to require the microtexturing to be “continuous,” then they would have used the adverb “continuously” instead of “continuous,” our cases do not indulge hindsight. We are satisfied—based on the clear indications in the written description—that a person of ordinary skill would understand that when the laminate is stretched to the point of deformation, it is substantially the entire skin layer that develops substantially uniform microtexturing.

We have no occasion to address in detail the prosecution history because we conclude that none of the statements contained therein rise to the level of a clear disavowal or otherwise support a departure from the claim language and the written description. We have similarly considered comparisons to the Hanschen Patents but do not read those disclosures to change the meaning of the claims in the ’034 Patent. We *affirm* the district court’s interpretation of “continuous microtextured skin layer,” and as previously clarified, to be “continuous” the microtexturing is “substantially uniform” as opposed to limited to a single region or zone.

### C. “Preferential Activation Zones”

Eleven claim terms deriving from the baseline term “preferential activation zone” appear throughout the Hanschen Patents in claims 1, 19, 25, 29, 30, 51–53, 55, and 56 of the ’691 Patent and claims 1 and 4 of the ’428 Patent. In addition to “preferential activation zone” and

“preferential activation regions,”<sup>8</sup> the remaining derivative terms are as follows: (1) “non-preferential activation zones,” (2) “non-preferential activation regions,” (3) “elasticized preferential activation zones,” (4) “non-elasticized preferential activation zones,” (5) “treated to create preferential stress concentrations,” (6) “preferential stress regions,” (7) “will preferentially elongate when stretched,” (8) “will preferentially elongate and recover to form an elastic zone,” and (9) “zone activatable.” The district court addressed all eleven “preferential activation zone” terms, but in the interest of efficiency, we address the salient claim language “preferential activation zone” with the understanding that on remand the district court will be well-positioned to decide the overlapping terms consistent with the guidance set forth in this opinion.

The term “preferential activation zone” does not have an ordinary meaning outside of the Hanschen Patents, yet the claims specify that these zones are an area of the film laminate that will “preferentially elongate when stretched.” ’691 Patent col. 36 ll. 41-63. The presence of both elastic and inelastic zones is in contrast to the claims of the Krueger Patents, which contemplate “continuous” microtexturing once stretched. Use of the term “preferential activation zone” thus limits the area of elasticization to designated zones or regions on the laminate. It is unambiguous from the face of the claims that there are both areas on the laminate that become elastic when stretched and other adjacent areas that are generally inelastic.

The district court adopted Tredegar’s proposed construction and held that the “preferential activation zones”

---

<sup>8</sup> Our discussion of “preferential activation zone” applies equally to “preferential activation regions” based on representations made to the district court, and again on appeal, that the two terms are identical in meaning. *See* Appellee Br. 9 (citing J.A. 481–82).

must be “predetermined” and “identifiable” before activation. *Markman* Order at \*13. Based on this construction, the laminate must exist in two states—“an intermediate and a final state.” *Id.* The district court construed the term as “identifiable predetermined areas of the laminate that are inelastic and, when the laminate is stretched as a whole, will elongate before or to a greater extent than adjacent areas.” *Id.* at \*15. The parties first dispute whether the intrinsic evidence supports construing the zones as “predetermined” and “identifiable.” They also dispute how a “preferential activation zone” is formed.

3M maintains that the creation of the activation zone and the stretching can occur simultaneously. Specifically, it asserts that the specification teaches that “controlled localized stretching” requires the preferential elongation to occur in a single step. It proposes a construction for “preferential activation zone” that tracks the language of the claim: “the area of the multi-layer laminate which will preferentially elongate to form an elastic zone.”

Relying on the specification and prosecution history, Tredegar asserts that the use of “predetermined” in the specification warrants inclusion of that limitation in the district court’s construction. Tredegar also points to portions of the prosecution history to argue that a “preferential activation zone” is formed through a two-step process in which the selected laminate zones must progress through an intermediate state prior to activation.

We agree with 3M that the district court’s construction for “preferential activation zone” improperly reads “predetermined” and “identifiable” into the claims. The district court further erred in determining that the claims require preferential elongation to occur through a two-step process.

### 1. Plain and Ordinary Meaning

“Preferential activation zone” is a term specific to the claimed inventions and should be understood in a way that does not render the actual words of the claim super-

fluous. *Digital-Vending Sys. Int'l, LLC v. University of Phoenix, Inc.*, 672 F.3d 1270, 1275 (Fed. Cir. 2012) (discussing, *Phillips*, 415 F.3d at 1314). A skilled artisan encountering the term for the first time would have the patentee's own descriptions in the claims to frame the meaning of an otherwise unfamiliar reference. To that end, claim 1 provides a contextual description of "preferential activation zone." There are no express restrictions to limit a "preferential activation zone" as "predetermined" or "identifiable." There is similarly no mention of the laminate achieving an intermediate state prior to activation. Instead, the claims indicate only that the laminate's "preferential activation zone" will "preferentially elongate when stretched" and then later recover. '691 Patent col. 36 ll. 41-63.

For this claim term the patentee offers an ascertainable definition in the body of the claim, and our cases do not support prescribing a more particularized meaning unless a narrower construction is required by the specification or prosecution history. *E.g.*, *Woods v. DeAngelo Marine Exhaust, Inc.*, 692 F.3d 1272, 1285 (Fed. Cir. 2012) (declining to limit "angularly disposed" to any specific angle); *King Pharm., Inc. v. Eon Labs, Inc.*, 616 F.3d 1267, 1275 (Fed. Cir. 2010) (declining to limit the broad terms used in the [patent's] pharmaceutical claims to specific food conditions); *TI Grp. Auto. Sys.*, 375 F.3d at 1138 (clarifying that the claim term "at the bottom of the reservoir" need not be understood narrowly to be an opening "in the bottom surface of the reservoir"). Given that one of skill in the art is informed by the claim disclosures, it is unnecessary to limit the plain language based on unclear statements in the specification and prosecution history. *Thorner v. Sony Computer Ent. Am. L.L.C.*, 669 F.3d 1362, 1367 (Fed. Cir. 2012) (emphasizing that "[t]he patentee is free to choose a broad term and expect to obtain the full scope of its plain and ordinary meaning, unless the patentee explicitly redefines the term or disavows its full scope").



## 2. Written Description References

We consult the written description to determine whether the district court's claim construction encroaches on the straightforward definition provided in the claims. Based on the use of "predetermined," the district court limited the scope of the claims and required a "preferential activation zone" to have both clearly determined and identifiable properties.<sup>9</sup> We disagree.

Both 3M and Tredegar rely on the "predetermination" references in the specification, but the parties use the references differently in contesting whether the applicant narrowed the meaning of "preferential activation zone." The fundamental point of distinction is that, while Tredegar suggests that the zones must *exist* before activation, 3M suggests that the zones must be *selected* before activation. 3M contends that even if a region of the laminate is selected or predetermined for preferential elongation, the zone is not in existence until activation occurs.

The description in the Summary of the Invention is consistent with the broader understanding that a "preferential zone" can be "predetermined" or "selected" on the laminate without having yet undergone any of the alterations that accompany activation. It is apparent from a plain reading of the Summary of the Invention that the preferential activation regions are, in fact, "predetermined":

---

<sup>9</sup> Nowhere in the Hanschen Patent written description does the patentee characterize a "preferential activation zone" as "identifiable." As such, we see no basis to include the limitation in the claim construction. To the extent the district court relies on the discussion of relative modulus values in the prosecution history, it is using language connoting determination rather than identification. *See Markman* Order at \*12, n.10.

The novel, non-tacky microtextured laminate is obtained by stretching the laminate past the elastic limit of *predetermined* regions of the skin layers. This is termed *selective or preferential* activation. The laminate then recovers in these *predetermined* regions, which can be instantaneous, over an extended time period, which is skin layer controllable, or by the application of heat, which is also skin layer controllable.

'691 Patent col. 3 ll. 24-33 (emphases added). The disclosure indicates that microtexturing occurs by stretching "predetermined regions of the skin," and such an event is "termed *selective or preferential* activation." *Id.* (emphasis added). Rather than being mutually exclusive, the concepts of predetermination and selection are linked. *See* '691 Patent Abstract; col. 3 ll. 24-33. The flexible use of "predetermined" in the written description does not mean that, just because the zone can be predicted or chosen upon concentration of stress, the zone, as claimed, must exist prior to stretching. One of skill in the art would recognize that predetermination can be synonymous with selection. We therefore have a basis to presume that "preferential activation" appearing in the claims, refers to the same thing as "selective or preferential activation" in the Summary of the Invention. *See Digital-Vending Sys.*, 672 F.3d at 1275 (internal citations omitted). Because the written description treats both "selected" and "predetermined" regions as interchangeable in some circumstances, the claimed "preferential activation zones" are capable of selection upon concentration of stress in a particular region.

"Controlled localized stretching," as disclosed in the written description, weighs against a claim construction that artificially separates predetermination from activation. The disclosure teaches that localized stretching will result in selection and activation of one region of the laminate, while surrounding regions will not be activated. *See* '691 Patent col. 9 ll. 53-56, col. 9 ll. 61-63. Such acute

stretching provides the best illustration of simultaneous zone creation and activation because, in a single step, the interjection of stress both selects and activates the claimed zones.

The district court's use of "predetermined" in its claim construction does not take into account the "controlled localized stretching" that can create a "preferential activation zone" by applying acute stress to a localized region of the laminate. The passages discussing "controlled localized stretching" contemplate an alternative embodiment to that which the district court relies on in characterizing preferential activation as occurring prior to elongation. Our cases emphasize that an alternative means of accomplishing the claimed result weighs against a claim construction that would exclude that alternative. *Helmsderfer v. Bobrick Washroom Equip., Inc.*, 527 F.3d 1379, 1383 (Fed. Cir. 2008) (cautioning against interpreting a claim term in a way that excludes disclosed embodiments) (citing *Verizon Servs. Corp. v. Vonage Holdings Corp.*, 503 F.3d 1295, 1305 (Fed. Cir. 2007)).

Here, "controlled localized stretching" functions as such an alternative embodiment. As disclosed in column 3 of the '691 Patent, activation can be initiated through either uniform or localized stretching. '691 Patent col. 3 ll. 39-46. Both modes of activation create the claimed "preferential activation zone," but the treatment of the laminate varies depending on the type of stress applied to the laminate. Because there is no basis in the claim language to limit our understanding of the claim term and the disclosure teaches more than one activation method, the district court erroneously included "clearly determined [] properties." *Markman* Order at \*12.

### 3. Process of Creating a Preferential Activation Zone

The parties next argue over the related issue of whether the written description and prosecution history contemplate that the zones are created simultaneously at the point of activation or must first go through an inter-

mediate state to achieve elasticity. On this point, we hold that the “preferential activation zone” can be created and activated simultaneously. The elasticization of the zones does not require an intermediate, pre-activation state.

Tredegar’s argument for two distinct steps is premised on reading the claim to require the laminate to elongate when the “preferential activation zone” is created in a first step and activated in a second step. Such an understanding necessarily requires that “predetermined” zones be in existence exist prior to activation. As we have explained, however, the intrinsic evidence does not support this interpretation of “predetermined,” and we reject any attempt to adopt an initial step that is separate and distinct from the activation step defined in the claims and specification.

Tredegar’s most compelling argument for a two-step process is based on examiner statements during reexamination of the ’691 Patent. There, in distinguishing the claims from prior art, the examiner noted that claim 1 is drawn to “a multi-layer film with activation zones, i.e., the laminate *before activation*,” and he further states that “claim 1 is directed to *an intermediate product before activation*, not the final product after activation.” J.A. 1004 (emphases added). Tredegar maintains that the examiner’s interpretation of “preferential activation zone” contemplates a two-step process.

While the examiner’s statements could make this a close question, we are guided by legal principles dictating that we rest on the statements made by the patentee over conflicting statements of an examiner because it is the patentee’s words that define the claim. *See Elbex Video, Ltd. v. Sensormatic Elec. Corp.*, 508 F.3d 1366, 1372–73 (Fed. Cir. 2007) (interpreting claim term in favor of patentee when an ambiguous statement made to examiner was not supported by a “shred of evidence from the specification”); *Renishaw PLC v. Marposs Societa’ per Azioni*, 158 F.3d 1243, 1250 (Fed. Cir. 1998) (“Ultimately, the interpretation to be given a term can only be deter-

mined and confirmed with a full understanding of what the inventors actually invented and intended to envelop with the claim.”). We are hesitant to rely too heavily on examiner statements over those of the patentee. Rather than relying on the examiner’s statement as dispositive for claim construction purposes, this court previously explained that an examiner’s statement during reexamination was, at most, representative of how one of skill in the art would understand the term. *Biagro Western Sales, Inc. v. Grow More, Inc.*, 423 F.3d 1296, 1303 (Fed. Cir. 2005). The same is true in this case; the claim construction is not decided based on isolated statements of one of skill in the art. *Cf. C.R. Bard, Inc. v. U.S. Surgical Corp.*, 388 F.3d 858, 869 (Fed. Cir. 2004) (determining there was a clear disavowal because the patentee, to overcome examiner’s rejection of that claim, made a clear statement during reexamination that limited the scope of the claim by adopting language substantially identical to language suggested by examiner).

Tredeggar neither argues nor provides evidence of a disclaimer in the original prosecution or the reexamination. In the absence of such a showing, we decline to narrow the meaning of the claim term. The district court erred in relying on the prosecution history to support its conclusion that a “preferential activation zone” must exist before the laminate is stretched. The record indicates that during the course of the original prosecution, the applicant was asked about the meaning of “preferential activation zone” and broadly defined the term in a manner consistent with the claim language.<sup>10</sup> We defer to the

---

<sup>10</sup> The applicant specifically stated:

[T]he preferential activation zone has been further defined as that area of the multi-layer laminate which will preferentially elongate when the laminate is stretched, which elon gate [sic] region can then recov-

plain meaning of the claims and statements made in the written description referencing “controlled localized stretching” to conclude that there is no requirement that a “preferential activation zone” exist in an intermediate state before it is stretched or activated.

\* \* \*

The term “preferential activation zone” is entitled to a broad meaning unencumbered by limitations not found in the claims, and the creation and activation of the claimed zone can occur simultaneously. We *reverse* the district court’s construction of “preferential activation zone,” as well as derivatives thereof and clarify the proper interpretation: “selected area[s] of the multi-layer laminate which, when stretched will elongate to form an elastic zone before or to a greater extent than other areas of the laminate.” The construction of derivative claim terms is *remanded* for a determination consistent with the conclusions articulated in this opinion.

#### D. “Ribbon”

The term “ribbon” appears in dependent claims 9 and 10 of the ’034 Patent. The term refers to a multi-layer laminate in the shape of a “ribbon.” The elastomeric “ribbon” disclosed in claims 9 and 10 requires at least two layers, one opaque layer and a colored layer. ’034 Patent col. 29 ll. 7-10. The opaque skin layer is a microtextured outer layer, *id.* at col. 29 ll. 7-10, and the colored core layer is elastomeric. *Id.* at col. 29 ll. 11-13. While the claims describe the “ribbon” in terms of color and texture, the words of the claim are silent as to a particular size or any specific dimensions of the claimed “ribbon.”

---

er (as described in the specification) to form an elastic zone in the multi-layer laminate.

J.A. 681–82.

In the proceedings below, the parties proposed competing constructions of “ribbon.” The parties generally agreed that a “ribbon” was a strip of film, but Tredegar proposed that the strip of film could be no wider than one inch. *Markman* Order at \*25. The district court construed “ribbon” to mean “a strip of film having a width of no more than one inch.” *Id.* at \*26. To support its construction, the district court relied on U.S. Patent No. 4,143,195 (“Rasmussen”), a prior art reference disclosing “ribbon-like strips” of a specified width. *Id.*; J.A. 532–33.

3M asserts that the district court’s construction was in error because requiring a width of no more than one inch defies the plain meaning of “ribbon” and is unsupported by the intrinsic record. Tredegar maintains that a width limitation is necessary because, in the absence of such a restriction, the claims would be indefinite under § 112, ¶ 2. Tredegar maintains that, to cure “ribbon” of its vagueness, it is proper to look to the Rasmussen reference cited on the face of the ’034 Patent.

It is axiomatic that we will not narrow a claim term beyond its plain and ordinary meaning unless there is support for the limitation in the words of the claim, the specification, or the prosecution history. *Douglas Dynamics, LLC v. Buyers Prods. Co.*, 717 F.3d 1336, 1342 (Fed. Cir. 2013); *Aventis Pharma S.A. v. Hospira, Inc.*, 675 F.3d 1324, 1329 (Fed. Cir. 2012) (citing *Philips*, 415 F.3d at 1312). In this patent, as in everyday parlance, the term “ribbon” has a customary meaning that is not subject to specific size requirements. It is also uncontested that the written description and prosecution history do not provide additional information as to the parameters of the claimed ribbon. *See Markman* Order at \*25.

Tredegar’s indefiniteness arguments are unavailing. In order to be indefinite, reasonable efforts at claim construction must result in a definition that does not provide sufficient particularity or clarity to inform a skilled artisan of the bounds of the claim. *Star Scientific, Inc., v. R.J. Reynolds Tobacco Co.*, 537 F.3d 1357, 1371

(Fed. Cir. 2008). Such insoluble ambiguity is not applicable for the term “ribbon” because, regardless of whether a “ribbon” is half an inch wide or 10 inches wide, the plain meaning is still ascertainable to one of skill in the art. One only need look as far as the highly detailed description in the claims to appreciate the scope of the claimed “ribbon.” *Wellman, Inc. v. Eastman Chemical Co.*, 642 F.3d 1355, 1367 (Fed. Cir. 2011) (explaining that to be definite claims must be amenable to construction and provide a boundary between what is claimed and what is not claimed). In the absence of vagueness in the claim term, there was no need to import the teachings of the cited Rasmussen reference. Indeed, our claim construction standards do not support exploring tangential prior art references to understand the meaning of the claims.<sup>11</sup> *Thorner*, 669 F.3d at 1365.

Because ordinary usage of ribbon comports with its use in the '034 Patent, it was against established principles of claim construction to impose an artificial one-inch width requirement. Based on the foregoing, we *reverse* the district court’s construction of “ribbon” and construe that term to mean, simply, a “strip of film.”

### III. CONCLUSION

For the foregoing reasons, this court *affirms* the district court’s claim constructions as to the terms “continuous contact” and “continuous microtextured skin layer of substantially the entire laminate” and provides specific

---

<sup>11</sup> While there may be a case in which a cited reference—when examined in tandem with the intrinsic record—bears on the meaning of a disputed claim term, these claims, specification, and prosecution history provide no basis to do so. This is especially true because the cited reference—Rasmussen—does not even claim a ribbon range that includes 1”. The 1” limitation is an arbitrary choice.



clarifications on the proper scope of the disputed terms. We *reverse* the district court's constructions as to the terms "preferential activation zone" and "ribbon." Finally, this court *remands* all issues for further proceedings consistent with this opinion.

**AFFIRMED-IN-PART, REVERSED-IN-PART,  
AND REMANDED**

COSTS

No costs.

**United States Court of Appeals  
for the Federal Circuit**

---

**3M INNOVATIVE PROPERTIES COMPANY AND 3M  
COMPANY,**  
*Plaintiffs-Appellants,*

v.

**TREDEGAR CORPORATION AND TREDEGAR FILM  
PRODUCTS CORPORATION,**  
*Defendants-Appellees.*

---

2012-1241

---

Appeal from the United States District Court for the District of Minnesota in No. 09-CV-3335, Judge Donovan W. Frank.

---

PLAGER, *Circuit Judge*, Concurring.

I join the opinion of Judge Reyna and his claim construction conclusions. This case is yet another example—and an extreme example—of problems with claim drafting and their ensuing consequences. To resolve the question of whether the Tredegar product infringed 3M's patents, the district court was called upon to construe some thirty separate terms, which it did in a fifty-five page opinion. We in turn are being asked to review a number of the district court's constructions. Since we treat claim construction as a question of law, we have reserved to the appellate courts the last word on words.

Our panel manages to agree on all but one of the contested constructions, affirming some and reversing some.

But we disagree on one particularly convoluted claim phrasing, unfortunately one that runs through many of the claims.

I appreciate that there are four different patents involved, and that the particular technology for manufacturing the product is quite detailed, although the products themselves are fairly basic—the material at issue is used for example in diapers. Nevertheless, when claims are larded with terms such as “substantially,” “preferentially,” and “relatively,” and when it takes four judges and some seventy pages of densely written opinions to find meaning in these terms, there is considerable evidence of a failure by the claim drafters to be clear and precise, and, beyond that, of a shortcoming in the patent examination process that permits claims to be so drafted.

Sometimes such ambiguity is the result of sloppy drafting, and sometimes it appears that claims are drafted with a degree of indefiniteness so as to leave room to later argue for a broad interpretation designed to capture later-developed competition. The problem is exacerbated when, as here, there is a conflicting or indeterminate written description and prosecution history with regard to the claim terms at issue. Claim construction then becomes a game of crystal ball gazing, not resolved until this court’s gaze is announced.

The particular claim construction issue that divides the three appellate judges provides a perfect example of the problem. The claim term, “continuous microtextured skin layer,” truly is perplexing. Does “continuous” apply to the microtexturing, the skin layer, or both? Does it mean the microtexturing is everywhere (except perhaps for manufacturing flaws), or can it cover only a part of the skin layer as long as that part is continuous? Relying on the Chicago Manual of Style, 3M argues that “continuous” and “microtextured” are adjectives that separately modify “skin layer,” and thus, the claim term does not require that the microtexturing itself be continuous. According to 3M, if the applicant wanted “continuous” to modify “mi-

crotextured,” the applicant would have used the adverb “continuously.”

3M makes an interesting argument to be sure. But the argument creates its own grammatical problems. For example, there is no comma between “continuous” and “microtextured.” And the Chicago Manual of Style also tells us that adjectives that separately modify a noun are generally separated by a comma, unless of course the second adjective is a unit with the noun being modified (which would favor Tredegar’s construction). *The Chicago Manual of Style* § 6.33 (16th ed. 2010). The applicant seems to have understood this comma concept, and in fact used it when referring in the written description to a “continuous, deeply textured, microstructured surface.” ’034 patent, col.15 ll.2-3. But the nuances of comma usage, like 3M’s adverb argument, seem to me a tenuous foundation for an entire claim construction on which substantial liabilities may rest. See *United States v. Palmer*, 16 U.S. 610, 638, 4 L. Ed. 471 (1818) (noting that “the use of the comma is exceedingly arbitrary and indefinite”); *United States v. Ron Pair Enterprises, Inc.*, 489 U.S. 235, 249, 109 S. Ct. 1026, 1035, 103 L. Ed. 2d 290 (1989) (characterizing a comma as a “capricious bit of punctuation”) (internal quotation marks omitted).

Much like the claim’s grammar, the written description provides little help deciphering the meaning of the disputed term. Certainly, the ’034 patent has a lot of disclosure: nearly 30 columns of it. The patent has 33 different examples, 16 tables, and 24 figures. The patent’s problem does not lie in the quantity of its disclosure; it lies in the disclosure’s relevance to the language used in the claims.

The applicant knew or should have known that the claim term “continuous microtextured skin layer” was highly relevant to the patented technology. The appli-

cant wrote the term nine times in the first eight claims.<sup>1</sup> Strangely, however, the disclosure does not reflect this relevance. “Continuous microtextured skin layer” does not appear one single time in the written description. The written description provides no discussion of “continuous microtextured skin layer,” no definition. Language resembling the claim term appears here and there, but mutated versions of claim terms often confuse more than they elucidate.

While ultimately I have voted to join Judge Reyna for the reasons I explain shortly, Judge O’Malley in her dissent-in-part makes an argument for the opposite construction based on the prosecution history. The argument is not without merit, although again, I do not find the prosecution history a shining example of clarity.

Cases like this—claim construction issues such as this one—may well deserve application of a principle analogous to the contract doctrine of *contra proferentem*. See Williston on Contracts § 32:12 (4th ed.). When a term is ambiguous, a crystal ball matter, the ambiguity should be construed against the draftsman. (Or better yet, the claim should simply be invalidated as indefinite, though our court has not seen fit to go there as yet.)

Without labeling it as such, we have already used this principle to construe claims for compliance with 35 U.S.C. § 112. See *Athletic Alternatives, Inc. v. Prince Mfg., Inc.*, 73 F.3d 1573, 1581 (Fed. Cir. 1996) (“Where there is an equal choice between a broader and a narrower meaning of a claim, and there is an enabling disclosure that indicates that the applicant is at least entitled to a claim having the narrower meaning, we consider the notice function of the claim to be best served by adopting the

---

<sup>1</sup> The term is included in claim 8, albeit with a typographical error in “continuous.”

narrower meaning.”); *see also* *A Theory of Claim Interpretation*, 14 Harv. J.L. & Tech. 1, 81 (2000).

The *contra proferentem* principle would require the applicant to draft clear claims, using simple, direct sentences,<sup>2</sup> proper grammar, and definitions in the written description where appropriate. It harmonizes with the notice function of patent law. It would result in applicants—and prospective patentees—investing more resources on the front end, during drafting, and less resources on the remedial end, during litigation. Better drafting of patent applications can only improve the efficiency of the patent system by clearly delineating a patentee’s property rights, thereby reducing wasteful and unnecessary litigation.

Specifically in this case, when I gaze in my crystal ball, I see, in addition to the verbal jousting, a district judge who struggled at length to make sense of the claims, and I see a patentee (more correctly a patent applicant) who had the last clear chance—infringement is after all a tort—to avoid this kind of unnecessary claim construction game.<sup>3</sup> My crystal ball tells me to vote

---

<sup>2</sup> Since claim clarity is so critical to defining a patentee’s property rights, I puzzle why claim drafters are expected to draft each claim as a tortuous, “wherein”-laden, run-on sentence. Nothing could be more conducive to less clarity. But this is a matter for the U.S. Patent and Trademark Office to resolve; *see* Manual of Patent Examination Procedure § 608.01(m) (stating that “each claim must be the object of a sentence”).

<sup>3</sup> It will be interesting to observe in the years ahead whether the new post-grant administrative review procedures under the AIA result in clearer and more defined terminology in claims. The recent surge in applications seeking the newly-available review procedures before the PTO suggests a significant opportunity is in the offing.

against the patentee's construction of "continuous micro-textured skin layer" and in favor of a competitor who should not have the risk of guessing wrong about what a claim term could possibly mean.

**United States Court of Appeals  
for the Federal Circuit**

---

**3M INNOVATIVE PROPERTIES COMPANY AND 3M  
COMPANY,**  
*Plaintiffs-Appellants,*

v.

**TREDEGAR CORPORATION AND TREDEGAR FILM  
PRODUCTS CORPORATION,**  
*Defendants-Appellees.*

---

2012-1241

---

Appeal from the United States District Court for the  
District of Minnesota in No. 09-CV-3335, Judge Donovan  
W. Frank.

---

O'MALLEY, *Circuit Judge*, concurring in part and dissent-  
ing in part.

I agree with and join the majority's well-reasoned rulings on three of the four claim terms in dispute: "continuous contact," "preferential activation zone," and "ribbon." I disagree, however, with its analysis and conclusion regarding the fourth claim term, "continuous microtextured skin layer." I believe the district court erred in its treatment of the term and its rejection of 3M Innovation Properties Company and 3M Company's (collectively, "3M") argument—that skin layers having regions with and without microtexturing are within the plain meaning of the term. To the extent the majority affirms these



errors, I dissent. Accordingly, I do not join Part II.B of the majority opinion. I would instead construe the term as follows.

### I.

Turning first to the claim language, I do not believe that it excludes a skin layer where the extent of the microtexturing is anything other than “continuous” over the entire surface. The term “continuous microtextured skin layer over substantially the entire laminate” appears in claims 1, 2, 5, and 6 of U.S. Patent No. 5,691,034 (“the ’034 patent”). The pertinent portion of claim 1 reads:

An elastomeric laminate consisting essentially of at least one elastomeric layer and at least one *continuous microtextured skin layer over substantially the entire laminate* wherein . . .

’034 patent col. 28 ll. 40–43 (emphasis added).

As a matter of grammar, the term is best interpreted as a skin layer that is continuous, microtextured, and extends over substantially the entire laminate. Under a natural reading of term, i.e., its plain and ordinary meaning, the word “continuous” modifies the term “microtextured skin layer.” This follows simply from the grammatical structure of the phrase. “Continuous,” as an adjective, modifies the noun “skin layer” (in the same way the adjective “microtextured” does). If this word were meant instead to describe the microtexturing, it would be more natural to use the adverb form, “continuously,” since adverbs modify adjectives. Any reader, including a person of skill in the art, would thus understand the plain and ordinary meaning of the phrase to require a continuous “skin layer,” not continuous microtexturing. And the plain and ordinary meaning is always our starting point in a claim construction analysis. *See Phillips v. AWH Corp.*, 415 F.3d 1303, 1312 (Fed. Cir. 2005) (en banc) (“We have frequently stated that the words of a claim “are generally given their ordinary and customary meaning.”).

Because the word “continuous” does not modify the word “microtextured,” I agree with 3M on this point.

The question we must next ask is what does it mean for the skin layer to be “microtextured?” If the word “continuous” in the claim language does not define that term, then what does?

Since I find the claim language to impose no clear exclusion of skin layers that contain intermittent areas of microtexturing, I examine the written description for a clear disavowal of such skin layers. While the written description contains some language that may require complete microtexturing, I do not believe these passages meet the high burden necessary to limit the claim scope. *See Bell Atl. Network Servs., Inc. v. Covad Commc'ns Grp., Inc.*, 262 F.3d 1258, 1268 (Fed. Cir. 2001) (“We have previously held that, in redefining the meaning of particular claim terms away from the ordinary meaning, the intrinsic evidence must clearly set forth or clearly redefine a claim term so as to put one reasonably skilled in the art on notice that the patentee intended to so redefine the claim term. We have also stated that the specification must exhibit an express intent to impart a novel meaning to claim terms.”) (internal citations and quotation marks omitted). Specifically, the written description states:

Whether the laminate is prepared by coating, lamination, sequential extrusion, or a combination thereof, the laminate formed and its layers will preferably have substantially uniform thickness across the laminate. Preferably the layers are co-extensive across the width and length of the laminate. With such a construction the microtexturing will be *uniform* over the elastomeric laminate surface.

'034 patent col. 10 ll. 33–36 (emphasis added).

By stating that the microtexturing is preferably “uniform” over the elastomeric laminate surface, the written description does not clearly require microtexturing over

the entire skin layer. First, this excerpt describes a preferred embodiment, to which claims typically are not limited. *See Phillips*, 415 F.3d at 1323 (“Although the specification often describes very specific embodiments of the invention, we have repeatedly warned against confining the claims to those embodiments.”). Second, it is unclear that “uniform” means “complete” or “continuous,” or that it refers to the amount of the skin layer that must exhibit microtexturing. It indicates instead, I believe, that the ridges in the skin layer that produce the microtexturing must have uniform dimensions,<sup>1</sup> regardless of

---

<sup>1</sup> These dimensions are discussed in further detail later in the same section of the patent:

FIG. 2 is a schematic diagram of the common *dimensions* which are variable for uniaxially stretched and recovered laminates. The general texture is a series of regular repeating folds. These variables are the total height A-A', the peak-to-peak distance B-B' and the peak-to-valley distance C-C'. These variables were measured for a series of polyolefin/styrene-isoprene-styrene/polyolefin laminates. General ranges for A-A', B-B' and C-C' were noted. For total height (A-A'), the range measured was from 0.79 to 32 mils (0.02 to 0.81 mm). For peak-to-peak distance (B-B'), or the fold period, the measured range was from 0.79 to 11.8 mils (0.025 to 0.30 mm). For peak-to-valley distance (C-C'), the measured range was from 0.04 to 19.7 mils (0.001 to 0.5 mm). These ranges are only exemplary of the surface characteristics obtainable by the practice of the present invention. Laminates of other compositions will demonstrate different microstructures and microstructure dimensions. It is also possible to obtain dimensions outside the above ranges by suitable

how far over the surface those ridges extend. This is not to say that it was unreasonable for the majority or the district court to find some useful guidance in this passage. But, since it is at the least subject to varying interpretation, I believe the passage fails to meet the high burden necessary to limit claim scope. *See Bell Atl.*, 262 F.3d at 1268.

Turning next to the prosecution history, while it does clearly limit claim scope, it does not do so in the way the district court believed. The '034 patent was rejected for obvious-type double patenting over U.S. Patent No. 5,344,691 (“the '691 patent”). To overcome the rejection, the applicants stated:

Claim 1 of the '691 patent essentially claims a multi-layer film laminate with “preferential activation zones” and “non-preferential activation zones.” The multi-layer film laminate preferentially elongates in the preferential activation zones forming an elastomeric laminate only in these zones. The invention disclosed in the '691 patent is patentably distinct from that claimed in the instant application at least in that claim 38 et al. of the instant application do not teach or suggest how to provide a laminate having these preferential and non-preferential activation zones. *Rather, the instant claims are limited to a laminate material which is elastomeric over substantially the entire laminate.*

J.A. 1460–61 (emphasis added).

---

selection of core/skin ratios, thicknesses, stretch ratios and layer compositions.

'034 patent col. 10 l. 62 – col. 11 l. 14 (emphasis added). In fact, all of columns 11 and 12 of the '034 patent describe the different characteristics the microtexturing can have.

The laminate is elastomeric where it is microtextured. Therefore, this statement requires laminate material that is microtextured over “substantially the entire laminate.” But this statement does not require “continuous” or “complete” “microtexturing.” The microtexturing must extend “over *substantially* the entire laminate,” not over *all* of it. Discontinuities in the microtexturing are still within the scope of the claim term, so long as they do not reduce the microtexturing below a “substantial” portion of the laminate. This word of degree, “substantially,” was sufficient to overcome the obviousness type double patenting rejection. The claims require no more. What is “substantial” and whether an accused product qualifies as such seems to me a question of fact for a jury to resolve. See *TechSearch, L.L.C. v. Intel Corp.*, 286 F.3d 1360, 1369–70 (Fed. Cir. 2002) (“Whether the accused device contains an element corresponding to each claim limitation or its equivalent is a question of fact.”); *Crystal Semiconductor Corp. v. TriTech Microelectronics Int’l, Inc.*, 246 F.3d 1336, 1345 (Fed. Cir. 2001) (“Application of the claim to the accused device is a question of fact.”).

I ultimately believe the wording of the district court’s construction was very close to the correct one. Much like the trial court, I would construe the term as “a continuous skin layer, with microtexturing that extends over substantially the entire surface area of the laminate.” I do not agree, however, with the district court’s construction to the extent it requires that the “microtexturing” be “continuous” from start to finish.

## II.

In its claim construction opinion, the district court construed the term “continuous microtextured skin layer over substantially the entire laminate” as “substantially the entire surface area of the laminate.” *3M Innovative Prop. Co. v. Tredegar Co.*, No. 09-3335, 2011 WL 6004023, at \*24 (D. Minn. Nov. 30, 2011). On its face, the district court’s construction seems to be one which requires microtexturing that extends over “substantially the entire

surface area of the laminate,” a construction with which I would agree.

The district court, however, went on to reject 3M’s argument that “the term ‘continuous’ relates to the skin layer but not the microtexturing and thus does not require continuous microtexturing.” *Id.* at \*23. As discussed above, I disagree with this aspect of the district court’s construction; I agree with 3M.

The district court based this explanation of the scope of its construction on a distinction it saw between the two families of patents involved in this case—the “Kreuger patents” (the ’034 patent and U.S. Patent No. 5,501,679 (“the ’679 patent”)) and the “Hanschen patents” (U.S. Patent No. 5,468,428 and the ’691 patent”):

While both the Hanschen and the Krueger patents relate to multi-layer laminates that are stretched beyond the skin layer’s deformation [limit] to become elastic, the Hanschen and Krueger Patents differ in the following way: in the Hanschen Patents, only certain regions of the laminate are stretched beyond the deformation limit (and therefore the laminate has regions both with and without a microtextured surface); and the Krueger Patents do not teach a laminate with the different regions or zones (preferential activation zones that are stretched to have a microtextured surface and non-preferential zones that do not have a microtextured surface). In addition, the ’034 Patent teaches that microstructuring is continuous.

*Id.* Based on this distinction, the district court held that the microtexturing must be “continuous,” or, that is, the claims of the ’034 patent do not cover skin layers with regions that are not microtextured.

But, the distinction between the two families of patents does not mandate this conclusion. I agree that the Hanschen patents disclose laminates with regions that are microtextured and regions that are not. But there is

no basis to view the two families of patents as mutually exclusive. The Kreguer patents, in my opinion, are not limited to laminates that are *fully* microtextured. And the earliest filed Kreuger patent (the '679 patent) and Hanschen patent (the '691 patent) share the same filing date, making it conceivable that the Kreguer family is a broader one, covering various subspecies (i.e., fully-microtextured and partially-microtextured laminates), while the Hanschen family is drawn only to one of those subspecies (partially microtextured laminates).

### III.

Turning next to the majority's analysis, I do agree with some of it, in particular, the statement that "[c]lose examination of the intrinsic and extrinsic references supports the middle path identified by the district court in which a skin layer can have non-microtextured areas, but the microtexturing encompasses 'substantially the entire surface area of the laminate.'" *Majority Op.* at 19–20. This seems to fully align with my conclusion. If the majority reached this holding through the analysis I lay out above, I happily would join.

But the majority determines that "the written description is unambiguous in teaching that the microtexturing is continuous." *Id.* at 20. As discussed above, I disagree. I believe the microtexturing need not be "continuous;" it only needs to extend over *substantially* the entire laminate.

The majority also looks for a potential narrowing of claim scope in the claim language or written description. Specifically, the majority asks whether the specification *limits* the microtexturing to "a single region." *See id.* ("The written description is unambiguous in teaching that the microtexturing is continuous, *but not restricted to a single zone or region of the skin layer.*") (emphasis added); *id.* at 21 ("By contrast, there is no discussion in the written description that minimizes the microtexturing *to 3M's suggested single region of the skin layer.*") (emphasis

added); *id.* at 21 (“We *affirm* the district court’s interpretation of ‘continuous microtextured skin layer,’ and as previously clarified, to be ‘continuous’ the microtexturing is ‘substantially uniform’ *as opposed to limited to a single region or zone.*”) (second emphasis added). This reasoning turns the disclaimer analysis on its head. The relevant inquiry is not whether the microtexturing is *limited* to a single region, but whether the term “continuous microtextured skin layer” was narrowed to exclude partially-microtextured skin layers, such as those with microtexturing in only one region.

Perhaps the majority was led astray by 3M’s proposed construction: “one unified skin layer over substantially the entire laminate having at least one microtextured region.” But this construction does not limit the microtexturing to a single region. Instead, it merely requires “at least” one microtextured region—thus including within its scope skin layers with some regions having no microtexturing, so long as at least one region is microtextured. Under this construction, the skin layer must be at least partially-microtextured, a concept with which I agree. I do, however, ultimately reject 3M’s construction to the extent it reads on skin layers with microtexturing that does not extend over *substantially* the entire laminate.

#### IV.

To conclude, I believe the term “continuous microtextured skin layer over substantially the entire laminate” should be construed as “a continuous skin layer, with microtexturing that extends over substantially the entire surface area of the laminate,” effectively the same wording employed by the district court. I disagree, however, with the majority and the district court to the extent they believe this construction requires “continuous microtexturing” over the entire skin layer. No such requirement is mandated by the patents-in-suit. I dissent from the portions of the majority opinion so holding and would reverse the district court’s similar ruling.