

**IN THE UNITED STATES DISTRICT COURT
NORTHERN DISTRICT OF ILLINOIS
EASTERN DIVISION**

THE CHAMBERLAIN GROUP, INC.,)	
)	
Plaintiff,)	
)	
v.)	No. 14-cv-05197
)	
LINEAR LLC, AND NORTEK SECURITY)	
& CONTROL LLC,)	
)	
Defendants.)	

MEMORANDUM OPINION AND ORDER

AMY J. ST. EVE, District Court Judge:

Plaintiff The Chamberlain Group, Inc. (“Chamberlain”) is a Connecticut corporation with a principal place of business in Elmhurst, Illinois. (R.51, Second Amended Complt., ¶ 1.) Chamberlain sells garage door openers and related accessories. (*Id.*, ¶¶ 2, 3.) Defendant Nortek Security & Control LLC (“Nortek” or “Defendant”)¹ is a California company that offers products in a variety of security-related industries, including the access control industry. (*Id.*, ¶¶ 12, 13.) Chamberlain filed its initial complaint on July 9, 2014 and an Amended Complaint on December 29, 2014, both alleging Defendant infringed U.S. Patent Nos. 6,998,977 (“the ‘977 Patent”), 7,852,212 (“the ‘212 Patent”), and 8,144,011 (“the ‘011 Patent”). (*See* R.1, Complt.; R.27, First Amended Complt.) On March 3, 2015, Chamberlain filed a Second Amended Complaint which retained the allegations of infringement for the ‘977 Patent, the ‘212 Patent, and the ‘011 Patent, and further alleged infringement of U.S. Patent Nos. 7,489,923 (“the ‘923 Patent”) and 7,876,218

¹ Linear LLC was renamed Nortek Security & Control LLC in 2014 (R.27, ¶ 12.) The two defendants listed in the caption are therefore treated as a single entity and referred to herein as “Nortek” or “Defendant”.

(“the ‘218 Patent”). (*See* R.51.) Before the Court is Defendant Nortek’s motion to dismiss the Second Amended Complaint pursuant to Federal Rule of Civil Procedure 12(b)(6) for failure to recite patent eligible subject matter pursuant to 35 U.S.C. § 101. (*See* R.53.) The Court has original jurisdiction of this patent infringement action pursuant to 28 U.S.C. §§ 1331 and 1338(a). (*See* R.51, ¶ 22.)

BACKGROUND

I. U.S. Patent No. 6,998,977

The ‘977 Patent, entitled “Method and Apparatus for Monitoring A Movable Barrier Over A Network” was filed on June 26, 2003 and issued on February 14, 2006. (R.54-1, ‘977 Patent.) The ‘977 Patent lists two inventors, Eric M. Gregori and Eric Peterson, and is assigned to Chamberlain. (*Id.*) The ‘977 Patent is directed to opening and closing a movable barrier, e.g., a garage door, a gate, a door, or a window, by sending status signals and requests over a computer network, e.g., the Internet. (*Id.*, col.1:44-67; col.2:35-38.) The claimed apparatus and methods of the ‘977 Patent respond to “a need for a monitoring system for a movable barrier which can solve the problems.” (*Id.*, col.1:38-39.) The specification details the problem—generally due to human error—solved by the ‘977 Patent when “a movable barrier may be left open when the user intended that it be closed.” (*Id.*, col.1:24-25.) In particular, the specification discloses apparatus and methods for monitoring the status of a garage door or other movable barrier. (*Id.*, col.3:54-61.) The status can then be checked over the Internet using a standard “web enabled cellular telephone or PDA.” (*Id.*) Figure 1 depicts a functional block diagram of a system for monitoring a movable barrier:

Fig. 1

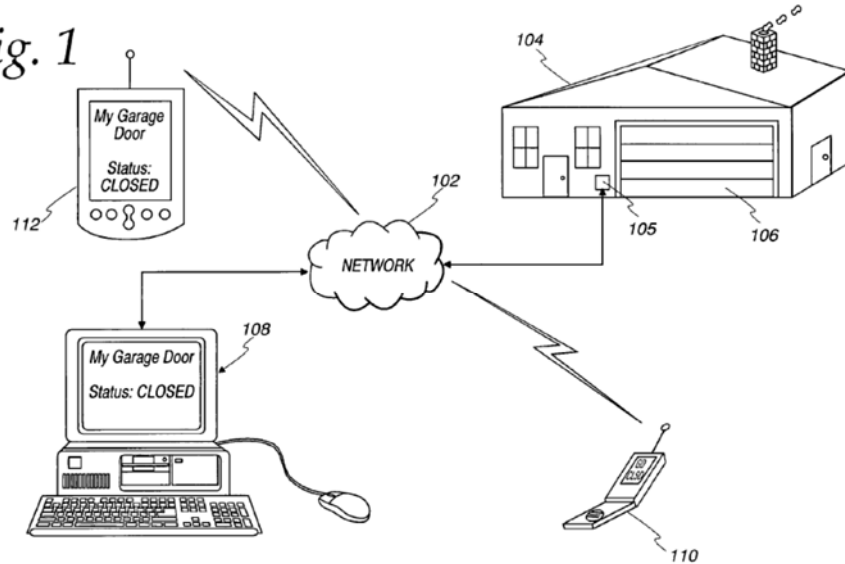

(R.54-1, Fig. 1; *id.*, col.2:6-7, 25-38.) The system disclosed in the '977 Patent adds network connectivity to movable barrier operators which can then allow a variety of remote devices, such as smartphones, to obtain the status of the door and open or close the door remotely. (*Id.*, col.4:54-58.) The '977 Patent has three independent claims—two directed to an apparatus and one directed to a method for checking the status of the movable barrier. Claim 1 of the '977 Patent states:

1. An apparatus comprising:
 - a movable barrier operator including a controller for controlling movement of a moveable barrier; and
 - a network interface electronically connected to the controller for connecting the controller to a network;wherein the network interface responds to requests received on the network by sending a status of the movable barrier over the network and;
wherein the network interface receives a status change request from the network and the controller responds to the status change request by moving the barrier.

(*Id.*, col.5:5-15; *see also id.*, col.6:27-39 (Claim 22 directed to an apparatus).) Claim 12 recites a method for checking the status of a movable barrier and states:

12. A method for checking the status of a movable barrier comprising the steps of:
receiving from a network client over a network, a status request for a movable barrier;
determining a status of the movable barrier;
sending a status of the movable barrier over the network to the network client in response to the status request and;
wherein the movable barrier comprises a barrier movement operator for controlling the movement of the barrier and the method comprises receiving a status change request from the network client and controlling movement of the barrier in response to the status change request.

(R.54-1, col.5:38-col.6:4.)

II. The Alarm System Patents

The remaining four patents asserted against Nortek are related and entitled “Alarm System Interaction with a Movable Barrier Operator Method and Apparatus” (the “Alarm System Patents”). (See R.54-5, at 1; R.54-4, at 1; R.54-3, at 1; R.54-2, at 1.) The inventor of the Alarm System Patents, James Joseph Fitzgibbon, filed the first application in the Alarm System Patents family, U.S. Patent Application No. 11/044,928, on January 27, 2005, which issued as the ‘923 Patent on January 27, 2009. (R.54-5, at 1.) Continuations of the ‘923 Patent issued as the ‘218, ‘212, and ‘011 Patents, all of which share a common specification. (See R.54-3, at 1, “Related U.S. Application Data”.) The Alarm System Patents generally describe connecting a movable barrier, e.g., a garage door opener, to a home or business alarm or automation system to carry out a number of functions and are each assigned to Chamberlain. (See R.54-5, at 1; R.54-4, at 1; R.54-3, at 1; R.54-2, at 1.) Figure 2 of the Alarm System Patents depicts how the “movable barrier operator 23” connects to a special “secure communication link interface 22” via a “secure communication link 24,” and then to an “alarm system controller 21”:

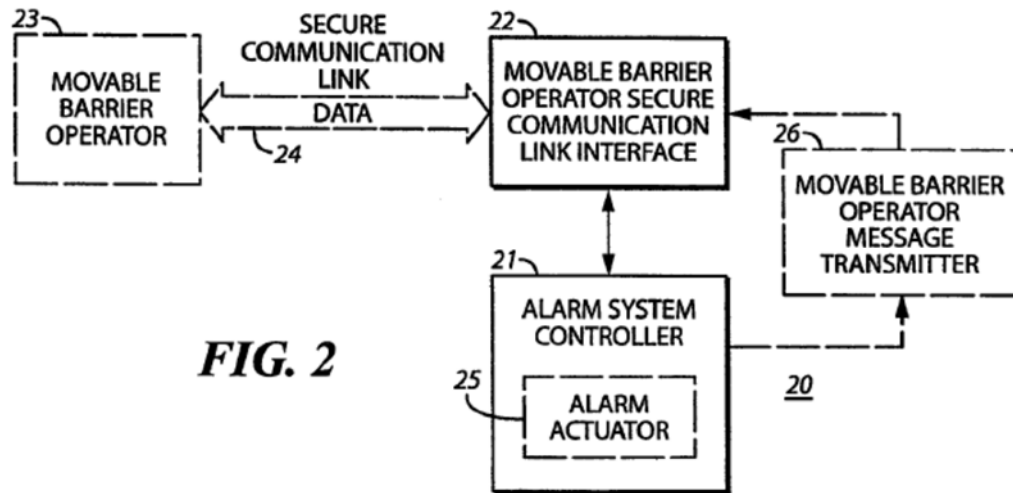

FIG. 2

(R.54-5, Fig. 2; *see also id.*, col.3:46-3:64.) The specification describes the illustrative embodiment shown in Figure 2, stating:

[T]he alarm system controller 21 operably couples to a movable barrier operator secure communication link interface 22. The latter, in turn, comprises the interface that effects compatible interaction with a corresponding movable barrier operator 23 via a given secure communication link 24. So configured, the alarm system controller 21 is able to receive data from the movable barrier operator 23 via the secure communication link 24. As per these teachings, the alarm system controller 21 is then able to respond in some appropriate way to such received data.

(*Id.*, col.3:62-col.4:4.) The secure communication link of the Alarm System Patents can communicate signals from the garage door opener to the security system (e.g., indicating whether the door is open or closed), and from the security system to the garage door opener (e.g., to open or close the door). (*Id.*, col.2:45-52, 3:38-41.) The secure communication link prevents outsiders from compromising the system, such as by surreptitiously opening a closed garage door, or by falsely reporting to a user that the door is closed when it is actually open. (*See id.*, col.5:6-41.) The Alarm System Patents identify benefits of the claimed integration as including delaying the actuation time for the alarm system until after the garage door has closed (*id.*, col.2:40-51), disarming the alarm system upon opening of the garage door (*id.*, col.4:22-32), and

detecting an unauthorized opening of the garage door and providing a signal to a peripheral alarm system (*id.*, col.5:7-19).

A. The '923 Patent Claims

The '923 Patent contains both method claims and system claims. The method claims are directed to: (1) methods for communicating between a peripheral alarm system and a movable barrier operator controlling movement of a movable barrier, e.g., garage door (Claim 1), and (2) methods for use by an intrusion detection alarm system for communicating with a garage door opener controlling movement of a garage door (Claim 11). (*See generally*, R.54-5, col.5:48-col.8:14.) The system claim is directed to an alarm system comprising a movable barrier operator, a movable barrier operator secure encrypted communication link interface, and an alarm system controller (Claim 3). The independent claims of the '923 Patent state:

1. A method for communicating between a peripheral alarm system and a movable barrier operator controlling movement of a movable barrier, the method comprising:
providing a secure encrypted wireless communication link between the movable barrier operator and the peripheral alarm system;
effecting at least one encrypted wireless information communication from the movable barrier operator to the peripheral alarm system using the secure encrypted wireless communication link; and
performing a peripheral alarm system action in response to the encrypted wireless information communication from the movable barrier operator to the peripheral alarm system,
wherein the moveable barrier operator is configured to receive secure encrypted signals from a user input via a remotely located user interface and wherein effecting the at least one encrypted wireless information communication further comprises providing an instruction from the movable barrier operator to the peripheral alarm system for the peripheral alarm system to take an action, and
wherein the method further comprises the peripheral alarm system action providing an encrypted wireless signal over the secure communication link to instruct the movable barrier operator to take an action.

(R.54-5, col.5:48-col.6:7.)

3. An alarm system comprising:
a movable barrier operator secure encrypted communication link interface;
an alarm system controller that is responsive, at least in part, to data from a movable barrier operator as is received via the movable barrier operator secure encrypted communication link interface;
wherein the alarm system controller comprises an alarm actuator having a corresponding actuation time delay, wherein a first mode of operation of the actuation time delay is alterable, at least in part, in response to reception of data from a movable barrier operator via the movable barrier operator secure encrypted communication link interface.

(*Id.*, col.6:13-26.)

11. A method for use by an intrusion detection alarm system for communicating with a garage door opener controlling movement of a garage door, the method comprising:
receiving from the garage door opener, via a secure encrypted communication link, information regarding at least one of operational status and received operational commands as corresponds to the garage door opener;
effecting at least one intrusion detection alarm system action in response to the information received from the garage door opener.

(*Id.*, col.7:5-14.)

B. The '218 Patent Claims

The independent system claim of the '218 Patent is directed to an egress control system comprising a movable barrier operator, a secure encrypted information communication link interface, and a peripheral system controller (Claim 6). The independent method claims are directed to: (1) methods of controlling access to a secured area with a movable barrier operator and a movable barrier, a secure wireless encrypted communication link, and a peripheral control system (Claims 1 and 11); (2) methods for communicating between a movable barrier operator that controls a movable barrier and a peripheral device outside of the movable barrier operator using a secure encrypted communication link (Claims 12, 16, 19, and 21); and (3) methods for using a peripheral device for communicating with a garage door opener controlling movement of a garage door (Claim 22). (*See generally*, R.54-4, col.5:58-col.10:15.)

C. The ‘011 Patent Claims

The independent claims of the ‘011 Patent are directed to an apparatus comprising a movable barrier operator, a secure encrypted communication link interface, and a peripheral alarm system. (*See generally*, R.54-3, col.6:5-col.8:48.)

D. The ‘212 Patent Claims

The independent claims of the ‘212 Patent are directed to methods for communicating between a peripheral alarm system and a movable barrier operator that controls movement of a movable barrier. (*See generally*, R.54-2, col.6:5-col.8:61.)

LEGAL STANDARD

I. Rule 12(b)(6)

“A motion under Rule 12(b)(6) tests whether the complaint states a claim on which relief may be granted.” *Richards v. Mitcheff*, 696 F.3d 635, 637 (7th Cir. 2012). Under Rule 12(b)(6), a plaintiff’s “[f]actual allegations must be enough to raise a right to relief above the speculative level.” *Bell Atlantic Corp. v. Twombly*, 550 U.S. 544, 555, 127 S.Ct. 1955, 167 L.Ed.2d 929 (2007). Put differently, a “complaint must contain sufficient factual matter, accepted as true, to ‘state a claim to relief that is plausible on its face.’” *Ashcroft v. Iqbal*, 556 U.S. 662, 678, 129 S.Ct. 1937, 173 L.Ed.2d 868 (2009) (quoting *Twombly*, 550 U.S. at 570). “In reviewing a motion to dismiss a counterclaim, the Court must assume the truth of the facts alleged in the counterclaim, construe allegations liberally, and view them in the light most favorable to the counterclaim plaintiff. *See Centers v. Centennial Mortg., Inc.*, 398 F.3d 930, 933 (7th Cir. 2005); *Cozzi Iron & Metal v. U.S. Office Equip., Inc.*, 250 F.3d 570, 574 (7th Cir. 2001); *see also Alam v. Miller Brewing Co.*, 709 F.3d 662, 665-66 (7th Cir. 2013); *Teamsters Local Union No. 705 v. Burlington N. Santa Fe, LLC*, 741 F.3d 819, 823 (7th Cir. 2014). “In evaluating the

sufficiency of a complaint, ‘the court may also consider documents attached to the pleading without converting the motion into one for summary judgment.’” *Runnion ex rel. Runnion v. Girl Scouts of Greater Chicago and Nw. Ind.*, 786 F.3d 510, 528, n. 8 (7th Cir. 2015) (citing *Wigod v. Wells Fargo Bank, N.A.*, 673 F.3d 547, 556 (7th Cir.2012) & Fed. R. Civ. P. 10(c) (“A copy of any written instrument which is an exhibit to a pleading is a part thereof for all purposes”)); see also *Cole v. Milwaukee Area Technical Coll. Dist.*, 634 F.3d 901, 903 (7th Cir. 2011) (citations omitted) (“The consideration of a Rule 12(b)(6) motion is restricted to the pleadings, which consist here of the complaint, any exhibits attached thereto, and the supporting briefs.”) Where an exhibit conflicts with the allegations of the complaint, however, the exhibit typically controls. *Centers*, 398 F.3d at 933.

II. Patent Eligibility under 35 U.S.C. § 101

Section 101 of the Patent Act defines the subject matter eligible for patent protection and provides:

Whoever invents or discovers any new and useful process, machine, manufacture, or composition of matter, or any new and useful improvement thereof, may obtain a patent therefor, subject to the conditions and requirements of this title.

35 U.S.C § 101. For over 150 years, the Supreme Court has “held that this provision contains an important implicit exception: Laws of nature, natural phenomena, and abstract ideas are not patentable.” *Alice Corp. Pty. Ltd. V. CLS Bank Int’l*, ___ U.S. ___, 134 S.Ct. 2347, 2358, 189 L.Ed.2d 296 (2014) (citing *Association for Molecular Pathology v. Myriad Genetics, Inc.*, 569 U.S. ___, ___, 133 S.Ct. 2107, 2116, 186 L.Ed.2d 124 (2013)).

The concerns of pre-emption drive this exclusionary principle. See *Alice*, 134 S.Ct. at 2354 (citing *Bilski v. Kappos*, 561 U.S. 593, 612, 130 S.Ct. 3218, 3231, 177 L.Ed.2d 792 (2010)) (explaining how upholding the patent “would pre-empt use of this approach in all fields, and

would effectively grant a monopoly over an abstract idea”). The Supreme Court has repeatedly emphasized the concern for inhibiting “further discovery by improperly tying up the future use of these building blocks of human ingenuity.” *Id.* at 2354 (citing *Mayo Collaborative Servs. v. Prometheus Labs, Inc.*, 566 U.S. ___, 132 S.Ct. 1289, 1301, 182 L.Ed.2d 321 (2012) (citations omitted)). This preemptive concern is construed carefully, however, “lest it swallow all of patent law.” *Id.* (citing *Mayo*, 566 U.S. at ___, 132 S.Ct. at 1293-94). Patent claims that include an abstract concept are not deemed ineligible on that basis alone. *See id.* (citing *Diamond v. Diehr*, 450 U.S. 175, 187, 101 S.Ct. 1048, 1057, 67 L.Ed.2d 155 (1981)). Indeed, inventions that are “applications of such concepts to a new and useful end ... remain eligible for patent protection.” *Id.* (citing *Gottschalk v. Benson*, 409 U.S. 63, 67, 93 S.Ct. 253, 255, 34 L.Ed. 2d 273 (1972)). “Accordingly, in applying the § 101 exception, [courts] must distinguish between patents that claim the building blocks of human ingenuity and those that integrate the building blocks into something more, thereby transforming them into a patent-eligible invention.” *Id.* (quotations and citations omitted).

The Supreme Court has also recognized, however, that “too broad an interpretation of this exclusionary principle could eviscerate patent law.” *Mayo*, 132 S.Ct. at 1293; *see also Alice*, 134 S.Ct. at 2354. “For all inventions at some level embody, use, reflect, rest upon, or apply laws of nature, natural phenomena, or abstract ideas.” *Id.* Accordingly, the Supreme Court has explained that “an *application* of a law of nature or mathematical formula to a known structure or process may well be deserving of patent protection.” *Diehr*, 450 U.S. at 187; *see also Funk Bros. Seed Co. v. Kalo Inoculant Co.*, 333 U.S. 127, 130 (1948) (“If there is to be invention from [a discovery of a law of nature], it must come from the application of the law of nature to a new and useful end.”) (internal quotation marks omitted).

Keeping this balance in mind, the Supreme Court has established a two-step framework to guide lower courts in distinguishing between “those patents that claim laws of nature, natural phenomena, and abstract ideas from those that claim patent-eligible applications of those concepts.” *Alice*, 134 S.Ct. at 2355; *Mayo*, 132 S.Ct. at 1294, 1296-98. First, courts must “determine whether the claims at issue are directed to one of those patent-ineligible concepts.” *Alice*, 134 S.Ct. at 2355 (citing *Mayo*, 132 S.Ct. at 1296-97). If the claims are directed to a patent-ineligible concept, then courts must conduct an analysis to search for the “inventive concept”—“*i.e.*, an element or combination of elements that is ‘sufficient to ensure that the patent in practice amounts to significantly more than a patent upon the ineligible concept itself.’” *Id.* (citing *Mayo*, 132 S.Ct. at 1294). In doing so, the court must ask “what else is there in the claims before [it]?” and must “consider the elements of each claim both individually and ‘as an ordered combination’ to determine whether the additional elements ‘transform the nature of the claim’ into a patent-eligible application.” *Id.* (citing *Mayo*, 132 S.Ct. at 1298, 1297).

ANALYSIS

I. Addressing Patent Eligibility in a Motion to Dismiss

Patent eligibility² is a threshold issue of patentability and a question of law for the court. *See Bilski*, 561 U.S. at 621; *Dealertrack, Inc. v. Huber*, 674 F.3d 1315, 1333 (Fed. Cir. 2010). The Federal Circuit has treated Section 101 analyses like a jurisdictional inquiry and encouraged district courts to assess Section 101 patent eligibility “at the outset of litigation” to preserve judicial resources. *See Ultramercial, Inc. v. Hulu, LLC*, 772 F.3d 709, 717-19 (Fed. Cir. 2014)

² Patent *eligibility* does not mean *patentability* under, *e.g.*, 35 U.S.C. §§ 102 and 103. Defendant has not argued that the ‘977 Patent or the Alarm System Patents are invalid as anticipated by or obvious over prior art, nor have they argued that the claims at issue lack an adequate written description or are not enabled. Accordingly, the Court’s opinion regarding patent eligibility of the ‘977 Patent and the Alarm System Patents does not speculate on the invalidity of the claims at issue here.

(Mayer, J., concurring). Recently, the Federal Circuit has approved of district courts addressing challenges to patent eligibility at the pleading stage. *See e.g., Internet Patents Corp. v. Active Network, Inc.*, ___F.3d___, 2015 WL 3852975 (Fed. Cir. June 23, 2015) (affirming district court's dismissal of the complaints in four related actions for patent infringement on the ground of patent ineligibility under Section 101); *Content Extraction & Transmission LLC v. Wells Fargo Bank, Nat'l Ass'n*, 776 F.3d 1343, 1344 (Fed. Cir. 2014) (affirming district court's grant of the defendant's motion to dismiss under Rule 12(b)(6) on the ground that the claims were invalid as patent-ineligible under Section 101). Accordingly, the filing of motions to dismiss based on alleged patent ineligibility under Section 101 has dramatically increased. *See e.g., TriPlay, Inc. & TriPlay, Ltd. v. WhatsApp Inc.*, No. 13-1703-LPS, 2015 WL 1927696, at *1 (D. Del. Apr. 28, 2015); *Ameritox Ltd. v. Millenium Health, LLC*, No. 13-cv-832-wmc, 2015 WL 1915043 (W.D. Wis. Apr. 24, 2015); *Wireless Media Innovations, LLC v. Maher Terminals, LLC*, No. 14-7004, 2015 WL 1810378, at *1 (D.N.J. Apr. 20, 2015); *OpenTV, Inc. v. Apple, Inc.*, No. 14-cv-01622-HSG, 2015 WL 1535328, at *1 (N.D. Cal. Apr. 6, 2015); *Clear with Computers, LLC v. Altec Indus., Inc.*, 2015 WL 993392, at *1 (E.D. Tex. Mar. 3, 2015); *In re TLI Commc'ns LLC Patent Litig.*, ___ F.Supp.3d ___, 2015 WL 627858, at *1 (E.D. Va. Feb. 6, 2015); *Vehicle Intelligence & Safety LLC v. Mercedes-Benz USA, LLC*, No. 13 C 4417 (N.D. Ill. Jan. 29, 2015); *Money Suite Co. v. 21st Century Ins. & Fin. Servs., Inc.*, 2015 WL 436160, at *1 (D. Del. Jan. 27, 2015); *Morales v. Square, Inc.*, ___ F.Supp.3d ___, 2014 WL 7396568, at *9 (W.D. Tex. Dec. 30, 2014); *Cogent Med., Inc. v. Elsevier Inc.*, ___ F.Supp.3d ___, 2014 WL 4966326, at *1 (N.D. Cal. Sep. 30, 2014).

II. The ‘977 Patent Is Directed To Patent-Eligible Subject Matter

The claims of the ‘977 Patent are directed to apparatus and methods for opening and closing a door (or other movable barrier) after detecting and transmitting a message of the status of the door—as either open or closed. This claimed process for monitoring and controlling the operator of a movable barrier (i.e., facilitating the closing and opening of a door) constitutes a category of statutory subject matter under 35 U.S.C. § 101. *See* 35 U.S.C. § 101 (“Whoever invents ... process, machine, manufacture, or composition of matter ... may obtain a patent thereof ...”). The question remains, however, whether this process is directed to an exception—a law of nature, natural phenomena, or abstract idea. *See Alice*, 134 S.Ct. at 2354 (explaining that while the scope of Section 101 is broad, there is an “important implicit exception [to it]: [l]aws of nature, natural phenomena, and abstract ideas are not patentable”). Defendant argues that the ‘977 Patent is an exception to patent-eligibility because it is directed to an abstract idea. As such, the Court focuses its analysis under *Alice* to first address whether the ‘977 Patent claims are directed to the patent-ineligible concept of an abstract idea and if so, whether those claims include an inventive concept. *See id.* at 2355 (citations omitted).

A. The ‘977 Patent Claims Are Not Directed to Abstract Ideas

Defendant presents a very brief argument in support of its contention that the ‘977 Patent claims are directed to an abstract concept. Specifically, Defendant argues that the “movable barrier” claims—directed to opening and closing a door—are “as old as civilization.” R.54, at 10 (“Houses, gates, castles, and city walls have had ‘movable barriers’ for as long as humans have built dwellings.”) Plaintiff responds that the ‘977 Patent claims are directed to real-world, physical components: “a movable barrier operator (*e.g.*, a garage door opener) and a network interface connected to a controller of the garage door opener to connect the garage door opener

to a network.” (R.58, at 6.) Plaintiff further asserts that the ‘977 Patent claims are directed to categories of invention that are patent eligible. Namely, an invention that improves the operation of a computer system and an invention that uses a computer to operate something that would be on its own, patent-eligible. (R.58, at 7.)

An idea is abstract if it has “no particular concrete or tangible form.” *Ulramercial*, 772 F.2d at 715; *see also In re TLI Commc’ns.*, 2015 WL 627858, at *8 (An idea is abstract if it “describes a scheme or concept not tied to a particular concrete application”). Although the “precise contours of the ‘abstract ideas’ category” were not delimited in *Alice*, the Supreme Court and the Federal Circuit have provided some important principles that are instructive here. Namely, the Supreme Court has instructed that mathematical algorithms and fundamental economic and conventional business practices are abstract ideas. *See DDR Holdings, LLC v. Hotels.com LP*, 773 F.3d 1245, 1256 (Fed. Cir. 2014) (*citing Benson*, 409 U.S. at 64, 93 S.Ct. 253 (finding mathematical algorithms patent ineligible); *Bilski*, 561 U.S. at 611 (finding the “fundamental economic practice” of hedging to be patent ineligible); *Alice*, 134 S.Ct. at 2356 (same for intermediated settlement)). In addition, claims that “simply instruct the practitioner to implement the abstract idea of intermediated settlement on a generic computer” are also abstract. *DDR Holdings*, 773 F.3d at 1256 (*citing Alice*, 134 S.Ct. at 2359); *see also Ulramercial*, 772 F.3d at 715-16 (finding claims using advertising as a currency as applied to the particular technological environment of the Internet merely recited an abstract idea); *BuySAFE, Inc. v. Google, Inc.*, 765 F.3d 1350, 1355 (Fed. Cir. 2014) (finding claims patent ineligible that did nothing more than implement the abstract idea of creating a “transaction performance guaranty” over a network); *Accenture Global Servs., GmbH v. Guidewire Software, Inc.*, 728 F.3d 1336, 1344-45 (Fed. Cir. 2013) (finding claims patent ineligible that merely recited “generalized

software components arranged to implement an abstract concept on a computer”); *Bancorp Servs., LLC v. Sun Life Assur. Co. of Canada (U.S.)*, 687 F.3d 1266, 1278 (Fed. Cir. 2012) (finding claims patent ineligible that recited the use of a computer to implement the abstract idea of managing a stable-value protected life insurance policy). The claims at issue in the above cases “were recited too broadly and generically to be considered sufficiently specific and meaningful applications of their underlying abstract ideas ... [and] in substance were directed to nothing more than the performance of an abstract business practice on the Internet or using a conventional computer.” *DDR Holdings*, 773 F.3d at 1256. These type of claims are not patent-eligible. *Id.*

The ‘977 Patent claims do not fall within the contours of an abstract idea or patent-ineligible computer implementation of an abstract idea as they have physical and tangible components that are directed to more than performance of an abstract idea. *See id.* The ‘977 Patent claims use a computer network interface to facilitate communication between the movable barrier (e.g., a garage door) and a controller or operator that controls movement of the garage door in response to a status check or a status change request received on the network interface. Figure 2 of the Alarm System Patents, for example, illustrates a movable barrier operator for automatically opening and closing a barrier and depicts a garage door, guide rails, a ceiling, a wall, a power drive unit, an integrated drive rail, an operator arm, a trolley, a push button control unit, electrical conductors, network interface, a remote control transmitter, and an auxiliary power drive. (*See* R.54-5, Fig. 2.) These components are connected, in part, by a network interface. (*See id.*, Fig. 2; *id.*, Fig. 3.) The ‘977 Patent claims mirror the concept depicted by the Figures—physical and tangible components directed to performance of more than an abstract idea. Claim 1 of the ‘977 Patent, for example, is directed to an apparatus that has two

components: a network interface and a movable barrier operator—which includes a controller for controlling movement of a movable barrier. (*See* R.54-1, col.5:5-15.) Claim 22 is also directed to an apparatus that has a network interface, a barrier status monitor coupled to a movable barrier, and a controller coupled to both the network interface and the movable barrier. (*See id.*, col.6:27-39.) Claim 12 is directed to a method for checking the status of a movable barrier that includes the use of a barrier movement operator for controlling the movement of the barrier in response to a status change request. (*Id.*, col.5:38-col.6:4.) The steps of Claim 12 include receiving a movable barrier status request (from a network client), determining the status of the movable barrier, sending a status over the network in response to the network client’s movable barrier status request. (*Id.*)

The ‘977 Patent claims are not directed to apparatus and methods that are capable of being “performed mentally” nor are they the “equivalent of human mental work.” *See CyberSource Corp. v. Retail Decisions, Inc.*, 654 F.3d 1366, 1373 (Fed. Cir. 2011) (explaining that a “method that can be performed by human thought alone” is an abstract idea). In short, the ‘977 Patent claims are directed to opening and closing a movable barrier (e.g., garage door) using a computer network for communication between the monitor or operator (including a controller), and movable barrier. Indeed, Defendant understands the claims in this same manner. *See* R.54, at 1 (“The ‘977 Patent ... describes the idea of opening and closing a garage door or other “movable barrier” over the Internet”); *id.*, at 10 (“the claims are all directed to opening and closing a door”); R.59, at 5 (“Claim 1 narrows the abstract idea of moving a movable barrier ...”); *see also id.*, at 2 (“The Claims Are Directed to the Abstract Idea of Opening and Closing a Door” ... “The ‘977 claims, with the network and controller limitations stripped away, is [sic] directed to moving a barrier. Or, more colloquially, opening and closing a door”). Despite

agreeing that the claim is directed to real-work, physical opening and closing of a door, Defendant argues this is an abstract idea. The Court disagrees. Opening and closing—moving—a movable barrier in response to signals as to that barrier’s status is not an abstract idea. Monitoring the status of an open or closed movable barrier when the inquiring party is not in visual proximity of the movable barrier is not an abstract idea. An idea is abstract if it has “no particular concrete or tangible form.” *Ulramercial*, 772 F.3d at 715. The ‘977 Patent claims have a clear concrete and tangible form in that they are directed to monitoring and opening and closing a movable barrier—a particular tangible form, e.g., a garage door, gate, door, or window.

The exemplary cases upon which Defendant relies (*see* R.54, at 8, n.3) do not change the fact that the claims at issue here, are directed to a fundamental concept that, unlike those recited in the exemplary cases, is more than an abstract idea—more than a mental process. In *Digitech Image Techs., LLC v. Elecs. for Imaging, Inc.*, 758 F.3d 1344, 1351 (Fed. Cir. 2014), the Federal Circuit affirmed summary judgment of invalidity under Section 101 for claims directed to a process of taking two data sets and combining them into a single data set. In finding the claims invalid, the Federal Circuit explicitly noted that the claim “recited an ineligible abstract process of gathering and combining data that does not require input from a physical device.” *Id.*, 758 F.3d at 1351. Furthermore, it noted “nothing in the claim language expressly ties the method to an image processor” as the claim “generically recites a process of combining two data sets into a data profile; it does not claim the processor’s use of that profile in the capturing, transforming, or rendering of a digital image.” *Id.* Unlike the *Digitech Image* patent claims, the ‘977 Patent claims are explicitly tied to “a movable barrier operator including a controller for controlling movement of a moveable barrier.” (R.54-1, col.5:5-15.) The detection of the movable barrier’s status and relaying of that status over the communication network to the various integrated

physical components renders the claimed invention more than an abstract idea because it provides a “concrete and tangible form.” *See Ultramercial*, 772 F.3d at 715.

In addition, the claims “effect an improvement in [another] technology or technical field.” *See Alice*, 134 S.Ct. at 2539. The ‘977 Patent claims are not directed to a method for organizing human activity or computerizing a long-standing commercial practice. Rather, the claims are directed to a garage door opener and a network—the use of a computer in conjunction with a machine in a system. Defendant does not argue that a garage door opener, alone, is patent ineligible. The ‘977 Patent’s invention improves the technology or technical field by integration of a garage door opener and a network. Absent the integration, the garage door opener was limited. With the integration, the garage door opener can do new things like provide for remote monitoring and control of the garage door opener. The integration of the computer with the garage door opener, therefore, improves the technical field of a generic garage door and garage door opener.

In the single paragraph of Defendant’s opening brief asserting the ‘977 Patent claims are directed to an abstract concept, Defendant states: “[o]pening and closing a ‘movable barrier,’ of course, is as old as civilization. Houses, gates, castles, and city walls have had ‘movable barriers’ for as long as humans have built dwellings.” (R.54, at 10.) Defendant’s argument, however, treads too closely to allegations of novelty and obviousness. While it may be true that ancient civilizations used—and even, opened and closed—movable barriers, that analysis is more appropriately addressed as a question of what constitutes the prior art and whether the ‘977 Patent claims hold any novelty over the teachings of the prior art. *See Diehr*, 450 U.S. at 190 (“The question therefore of whether a particular invention is novel is ‘wholly apart from whether the invention falls into a category of statutory subject matter’”); *accord. Trading Techs. Int’l*,

Inc. v. CQG, Inc., No. 05-CV-4811, 2015 WL 774655, at *5 (N.D. Ill. Feb. 24, 2015) (“The inventive concept” step of the *Alice* analysis requires something different than pre-AIA §§ 102 and 103.”)

Accordingly, the ‘977 Patent claims—directed to opening and closing a movable barrier via communication over a computer network—encompass patent eligible subject matter and do not claim an abstract, mental process. The analysis under *Alice* consequently comes to an end.

B. Even if Considered an Abstract Idea, the ‘977 Patent Claims Include an Inventive Concept

Although the ‘977 Patent claims are not directed to an abstract idea, as explained above, even if the Court found the concept of opening and closing a door to be an abstract idea—as Defendant asserts—the ‘977 Patent claims would still clear the hurdle of § 101 patent eligibility because the claims include an inventive concept. The second step of the *Alice* framework requires the Court to determine whether a claim—found to be directed to an abstract idea—includes “additional elements” that transform the nature of the claim into something “significantly more” than the ineligible subject matter. *See Alice*, 134 S.Ct. at 2355. In doing so, the Court must ask “what else is there in the claims before [it]?” and must “consider the elements of each claim both individually and ‘as an ordered combination’ to determine whether the additional elements ‘transform the nature of the claim’ into a patent-eligible application.” *Alice*, 134 S.Ct. at 2355 (citing *Mayo*, 132 S.Ct. at 1298, 1297). The simple addition of using the internet in conjunction with an abstract idea is not an “inventive concept.” *Ultramercial*, 772 F.3d at 716 (“the use of the Internet is not sufficient to save otherwise abstract claims from ineligibility under § 101”); *Content Extraction*, 776 F.3d at 1348 (“[t]here is no ‘inventive concept’ in [the plaintiff’s] use of a generic scanner and computer to perform well-understood, routine, and conventional activities commonly used in the industry”).

The ‘977 Patent claims include additional elements that—considered individually and in combination—transform the nature of the claim into something significantly more than the idea of opening and closing a movable barrier. Defendant asserts that the ‘977 Patent claims “simply recite[] checking the status of a door, and then opening or closing that door, over a generic computer network.” (R.54, at 10.) This interpretation, however, is an oversimplification of the ‘977 Patent claims. Claim 1, for example, is an apparatus that in addition to using a computer network, uses a movable barrier operator which is connected to the network and used for automatically opening and closing a barrier (R.54-1, col.2:38-40.) Figure 2 of the ‘977 Patent depicts one embodiment of a movable barrier operator, which includes the garage door, guide rails, the fixtures of the ceiling and wall of the garage, a power drive unit, an integrated drive rail, an operator arm, a trolley, a push button control unit, electrical conductors, a remote control transmitter and an auxiliary power drive. (*See* R.54-1, col.2:38-col.3:35.) The specification and the claims, therefore, describe a movable barrier operator that has multiple components—more than the simple addition of a generic computer to check the status of a door and then open or close that door. Defendant ignores the garage door opener and controller, as well as ignoring the requirement for the network interface of the ‘977 Patent claims to be one that must connect the garage door opener to the network—a particular type of interface. The additional elements included in the ‘977 Patent claims provide an inventive concept beyond opening and closing a door. *See e.g., Fairfield Indus., Inc. v. Wireless Seismic, Inc.*, No. 4:14-CV-2972, 2014 WL 7342525, at *5-6 (S.D. Tex. Dec. 23, 2014) (finding claims to a method of data transmission that includes the additional elements of acquisition units to receive and transmit data from other acquisition units to contain an inventive concept and minimize the risk of preemption).

Although the machine-or-transformation test is not the sole test governing a Section 101 analyses, it can provide a “useful clue” in the second step of the *Alice* framework. *Bancorp Servs.*, 687 F.3d at 1278 (citing *Bilski*, 561 U.S. at 604) (“[W]hile not the sole test for deciding whether an invention is a patent-eligible ‘process,’” the machine-or-transformation test “remains a ‘useful and important clue, an investigative tool, for determining whether some claimed inventions are processes under § 101”). The Supreme Court has acknowledged that the machine-or-transformation test “may well provide a sufficient basis for evaluating processes similar to those in the Industrial Age—for example, inventions grounded in a physical or other tangible form.” *Bilski*, 561 U.S. at 605. Here, application of the machine-or-transformation test confirms the outcome reached by the Court. A claimed process can be patent-eligible under § 101 if: “(1) it is tied to a particular machine or apparatus, or (2) it transforms a particular article into a different state or thing.” *In re Bilski*, 545 F.3d 943, 954 (Fed. Cir. 2008) (en banc), *aff’d*, *Bilski*, 561 U.S. 593. In addition to being tied to a network and network interface, the claims of the ‘977 Patent are tied to a particular machine or apparatus. In particular, the claims are tied to a movable barrier operator that includes a controller that can control movement of the movable barrier (e.g., a garage door). This is not a claimed method or apparatus that can be performed or function without its machine components. Instead, the use of the movable barrier and controller are essential to the operation of the claimed methods. *See SiRF Tech., Inc. v. Int’l Trade Comm’n*, 601 F.3d 1319, 1333 (Fed. Cir. 2010) (finding a claimed GPS receiver to satisfy the machine-or-transformation test because it “played a significant part in permitting the claimed method to be performed” and put a meaningful limit on the scope of the claim). This connection, therefore, satisfies the machine prong of the machine-or-transformation test. The ‘977 Patent claims also satisfy the transformation prong of the test, as the controller responds to the status

change request by moving the barrier e.g., from an open to a closed position—thereby transforming the state of the movable barrier. *See Bilski*, 561 U.S. at 600 (citations omitted) (“A claimed process is surely patent-eligible under § 101 if: (1) it is tied to a particular machine or apparatus, *or* (2) it transforms a particular article into a different state or thing”).

Furthermore, this implementation of the idea of opening and closing a door—limited to the additional use of a movable barrier operator and a controller—does not preempt every technique for opening and closing a door. In particular, the claimed implementation is limited to a system that can identify the status of the door and change that status over a network. *See* R.54-1, col.5:5-15 (claim limitations reciting “responds to requests received on the network by sending a status of the movable barrier over the network” and “receives a status change request from the network[,], and the controller responds to the status change request by moving the barrier”). The ‘977 Patent claims directed to the opening and closing of a door tied to a movable barrier operator and controller are patent eligible.³

III. The Alarm System Patents Are Directed to Patent-Eligible Subject Matter

Defendant argues that the Alarm System Patents fail the *Alice* test because they are directed to an abstract idea—integrating an alarm system and a movable barrier operator to permit communication between the two. Defendant further argues that the Alarm System Patents fail to add an inventive concept. Plaintiff replies that the Alarm System Patents’ claims are not directed to an abstract idea because they are not methods of organizing human activity or carrying out long-recognized commercial activity. Instead, Plaintiff contends that the ‘977 Patent claims are directed to methods and processes that have physical, real-world methods that

³ Because the Court finds the elements of the independent claims of the ‘977 Patent to be directed to patent-eligible subject matter, the dependent claims that incorporate those limitations are also, therefore, patent-eligible.

use a machine and system, and are not about commerce or mental thought. As with the '977 Patent, because Defendant argues whether the Alarm System Patents are directed to an abstract idea, the Court focuses its analysis under *Alice* on first addressing whether the Alarm System Patents' claims are directed to the patent-ineligible concept of an abstract idea and if so, whether those claims include an inventive concept. *See Alice*, 134 S.Ct. at 2355 (citations omitted).

A. The Alarm System Patents' Claims Are Not Directed to an Abstract Idea

The Alarm System Patents are directed to monitoring the status of a movable barrier in such a way that a change in that status can set off an alarm or adjust the timing of an alarm disarmament or actuation. The claims of the Alarm System Patents—like those of the '977 Patent—include a limitation to a movable barrier operator that is configured to control movement of a movable barrier. (*See e.g.*, R.54-2 (claims 1, 4, 8, 12, 15, and 21); R.54-3 (claims 1, 8, 17); R.54-4 (claims 1, 6, 11, 12, 16, 19, 21); R.54-5 (claims 1, 3, 11); *see also* R.54-5 (claim 22) & R.54-5 (claim 11) (directed to a garage door opener controlling movement of a garage door).) The various embodiments of the Alarm System Patents include “a secure communication link between a movable barrier operator and a peripheral alarm system ... [that effects] at least one communication between these elements using that secure communication link.” (R.54-2, col.2:37-42.)

The claimed alarm system connected to a movable barrier operator falls within the realm of patent-eligible subject matter. The claims are directed to movable barrier operators and security systems that, individually, are the sort of mechanical and electrical systems that are patent-eligible. Indeed, the claimed methods of the Alarm System Patents could not be performed without the use of a movable barrier operator that controls a movable barrier in communication with an alarm system. This vital connection to the mechanical and electrical elements of the claim renders the claims at issue patent-eligible. *See SiRF Tech.*, 601 F.3d at

1333 (finding claims tied to a GPS receiver to be patent eligible because the methods could not be performed without a GPS receiver because it would be impossible to generate pseudoranges or to determine the position of the GPS receiver whose position is the precise goal of the claims). The claims integrate communication between two real-world systems that “can comprise an instruction to the movable barrier operator regarding subsequent movement of a movable barrier as is controlled, at least in part, by the movable barrier operator.” (R.54-4, col.3:28-31; *see also id.*, col.4:50-55 (describing the communication between the alarm system controller and the movable barrier operate to provide “a specific instruction to illuminate one or more lights, to move the movable barrier to a particular position, to maintain a present position of the movable barrier, and so forth”).) The claims require input from the physical devices of the movable barrier, the movable barrier operator and the alarm system controller, and the language of the claims expressly ties the methods and systems to at least one of these components. *See Digitech Image Techs.*, 758 F.3d at 1351 (finding claims patent ineligible because they recited an “abstract process of gathering and combining data that does not require input from a physical device”).

Furthermore, the Alarm System Patents’ claims improve the operation of each of the basic components—the garage door opener and the security system. In particular, the movable barrier operator, e.g., the garage door opener, can access the functionality of the alarm security system without illicit interference. Similarly, the security system’s capabilities are expanded to include monitoring and controlling the garage door opener. The improvement of providing communication between these basic components—individually, patent-eligible—also uses a computer with methods or systems that would otherwise be patent eligible absent the computers. *See Alice*, 134 S.Ct. at 2359-60.

The Alarm System Patents' claimed alarm system is more than an abstract idea as the patents disclose the monitoring of process variables and the means of setting off an alarm or adjusting an alarm system. Specifically, the Alarm System Patents disclose the means for setting an alarm and adjusting the alarm system to delay actuation time and disarmament of the alarm system upon opening of the garage door. (*See e.g.*, R.54-2, col.2:43-64.) These additional variables in the disclosure of the Alarm System Patents anchor the claimed subject matter to a particular tangible and concrete form, rendering it patent-eligible. *See Ultramercial*, 772 F.3d at 715. The Supreme Court's reasoning in *Parker v. Flook*, 437 U.S. 584, 98 S.Ct. 2522, 57 L.Ed.2d 451 (1978), is instructive here. In *Parker*, the Supreme Court found the claims patent-ineligible because they sought to protect a formula for computation of a number, an updated "alarm limit" calculated if certain variables were known, but did not provide any additional explanation as to how the variables were to be determined. *See Diamond*, 450 U.S. at 186-87 (*citing Parker*, 437 U.S. at 586) (finding claims patent ineligible, in part, because they failed to explain how to determine variables needed to calculate an updated alarm limit and did not purport "to contain any disclosure relating to the chemical processes at work, the monitoring of process variables, or the means of setting off an alarm or adjusting an alarm system"). The Alarm System Patents, unlike the alarm limit calculations in *Parker*, contain tangible components of the movable barrier operator and alarm system. In addition, the specification discloses use of the network to monitor and communicate regarding variables linked to the alarm system, e.g., open or closed status of the garage door.

Accordingly, the Alarm System Patents—directed to integrating an alarm system and a movable barrier to include communication between the two—do not claim an abstract idea and are patent-eligible subject matter. The analysis under *Alice*, therefore, ends.

B. Even if Considered an Abstract Idea, the Alarm System Patents' Claims Include an Inventive Concept

Although the '977 Patent claims are not directed to an abstract idea, as explained above, even if the Court found the concept of integrating an alarm system and a movable barrier operator to permit communication between the two to be abstract, the Alarm System Patents' claims would still clear the hurdle of § 101 patent eligibility because the claims include an inventive concept.

As noted above, the second step of the *Alice* framework requires the Court to determine whether a claim—found to be directed to an abstract idea—includes “additional elements” that transform the nature of the claim into something “significantly more” than the ineligible subject matter. *See Alice*, 134 S.Ct. at 2355. In doing so, the Court must ask “what else is there in the claims before [it]?” and must “consider the elements of each claim both individually and ‘as an ordered combination’ to determine whether the additional elements ‘transform the nature of the claim’ into a patent-eligible application.” *Id.* (citing *Mayo*, 132 S.Ct. at 1298, 1297). The simple addition of using the internet in conjunction with an abstract idea is not an “inventive concept.” *Ultramercial*, 772 F.3d at 716 (“the use of the Internet is not sufficient to save otherwise abstract claims from ineligibility under § 101”); *see also Content Extraction*, 776 F.3d at 1348.

The Alarm System Patents' claims include additional elements that—considered individually and in combination—transform the nature of the claims into something significantly more than mere communication. Defendant's characterization of the claims as directed to mere communication ignores the claims' specific ties to mechanical and electrical devices—a movable barrier operator and an alarm system controller. This connection is more than simply communication, as the claims rely on particular input and commands to operate—for example, the claims address particular commands that are to be relayed between the garage door opener

(e.g., a “movable barrier movement command”), and the action of physically moving the garage door (“performing a movable barrier operator action”) in response to receiving a particular signal from the alarm system. These and other additional commands and inputs of the claimed alarm systems and methods transform any abstract concept of communication between the two components into something significantly more than communication, rendering it patent-eligible subject matter. *See Alice*, 134 S.Ct. at 2355 (explaining the inventive concept as transforming the nature of the claim into something “significantly more” than the ineligible subject matter).

In addition, inclusion of the movable barrier operator and the alarm system satisfies the machine-or-transformation test, further confirming the patent-eligible nature of the claims. A claimed process can be patent-eligible under § 101 if: “(1) it is tied to a particular machine or apparatus, or (2) it transforms a particular article into a different state or thing.” *In re Bilski*, 545 F.3d 943, 954 (Fed. Cir. 2008) (en banc), *aff’d*, *Bilski*, 561 U.S. 593. The claims of the Alarm System Patents are tied to particular machines or apparatus—a movable barrier operator that includes a controller that controls movement of the movable barrier (e.g., a garage door), and an alarm system controller. As with the ‘977 Patent claims, these are not claimed methods or apparatus that can be performed or function without their machine components. *See SiRF Tech.*, 601 F.3d at 1333. Indeed, the claimed mechanical and electrical parts (movable barrier operator, movable barrier, and alarm system) and their ability to detect and respond to the status of the movable barrier (e.g., by respectively, closing or opening) are central to the invention. This connection to a combination of devices satisfies the machine prong of the machine-or-transformation test and renders the subject matter patent-eligible. *See id.* at 1332 (defining a “machine” as “a concrete thing, consisting of parts, or of certain devices and combination of

devices ... to perform some function and produce a certain effect or result”); *see also In re Ferguson*, 558 F.3d 1359, 1364 (Fed. Cir. 2009).

Furthermore, the integration of an alarm system and a movable barrier operator to permit communication between the two does not preempt every technique for the use of an alarm system in connection with opening and closing a door. In particular, the claimed implementation is limited to a system that can identify the status of the door and respond to or change that status over a network. *See e.g.*, R.54-5, col.5:59-col.6:7 (claim limitations of “performing a peripheral alarm system action in response to ... communication from the movable barrier operator” and “the peripheral alarm system action ... instruct[s] the movable barrier operator to take an action”). The Alarm System Patents’ claims directed to communication and response between an alarm system and a movable barrier operator are patent eligible.⁴

CONCLUSION

For the reasons discussed in detail above, the Court finds the ‘977 Patent and the Alarm System Patents to be directed to patent-eligible subject matter and denies Defendant’s motion to dismiss Plaintiff’s Second Amended Complaint pursuant to Rule 12(b)(6).

DATED: July 7, 2015

ENTERED

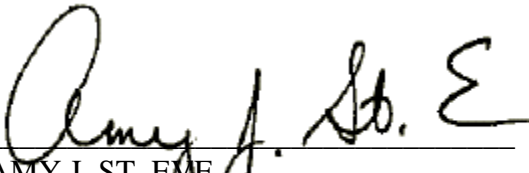

AMY J. ST. EME
United States District Court Judge

⁴ Because the Court finds the elements of the independent claims of the Alarm System Patents to be directed to patent-eligible subject matter, the dependent claims that incorporate those limitations are also, therefore, patent-eligible.