

NOT FOR PUBLICATION

**UNITED STATES DISTRICT COURT
DISTRICT OF NEW JERSEY**

_____)	
WADDINGTON NORTH AMERICAN, INC.,)	
)	
Plaintiff,)	
)	
v.)	Civil Action No. 09-4883 (GEB)
)	
SABERT CORPORATION,)	
)	MEMORANDUM OPINION
)	
)	
Defendant.)	
_____)	

BROWN, Chief Judge

This matter comes before the Court on two motions by Waddington North American (“WNA”) for relief from a jury verdict that found that certain of Sabert’s products did not infringe WNA’s patent and invalidated several of its claims. WNA requests relief in the form of a motion for judgment *non obstante veredicto* (“JNOV”) (Doc. No. 247), as well as a motion for a new trial (Doc. No. 248). Having considered the parties’ submissions, and having determined that the misconduct of Sabert’s counsel and witnesses was inexcusable and likely improperly influenced the jury’s verdict, the Court grants the motion for a new trial pursuant to Federal Rule of Civil Procedure 59(a). However, despite this ruling, the Court concludes that had the misconduct not occurred, a properly instructed jury could have reasonably reached a verdict for either party except as to written description. Thus, the Court denies the motion for JNOV with respect to the infringement of claim 25 and invalidity based on obviousness, but grants it with respect to written description.

I. BACKGROUND

This is a patent infringement case involving metalized plastic cutlery. Plaintiff, Waddington North American, is the assignee of the single patent at issue, U.S. Patent No. 6,983,542 (“the ‘542 patent”), for among other things, plastic eating utensils covered with a thin metallic coating of stainless steel that gives them the appearance of real metal cutlery. (Compl. at ¶ 12; Doc. No. 1). As depicted in cross section in Figure 4 of the patent, a vapor deposition process covers the underlying plastic substrate with a thin metallic coating:

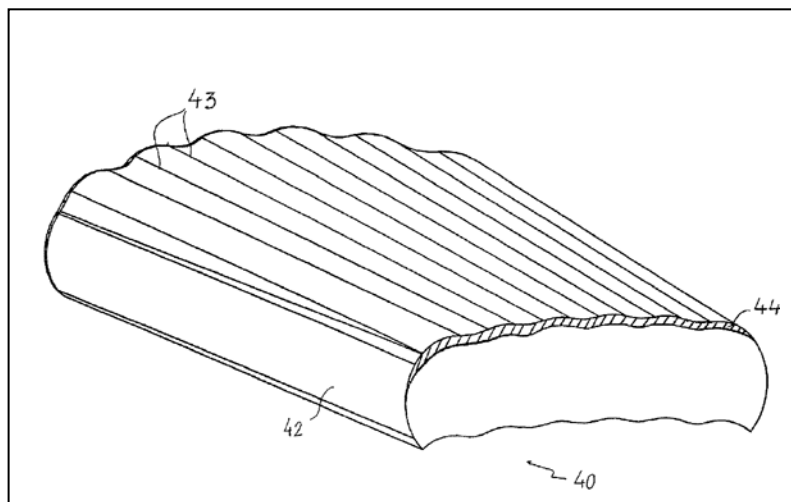

(‘542 patent, Fig. 4). The main difference between the diagram and the actual product is that that on the actual product the metallic coating is much thinner; it is only a few nanometers thick, far thinner than a human hair. Defendant Sabert Corporation originally produced similar utensils coated on both sides with stainless steel, but changed the product in an attempt to avoid infringement by using a titanium coating and making the plastic substrate opaque.

The claims at issue in this patent are not difficult to summarize. Claim 1 of the patent claims the following subject matter:

A metalized plastic food service item, comprising:

a plastic cutlery article having a display surface and an underside, said plastic cutlery article being adapted for placement on a table surface in a traditional table-setting presentation with said underside facing down towards said table surface and said display surface facing upwards; and

a thin metallic coating deposited on said display surface of said plastic cutlery article,

wherein said thin metallic coating is characterized by its suitability for food contact without an overcoat,¹ and is at least one of steel and stainless steel,

and wherein said thin metallic coating is of a sufficient thickness to impart a reflective metal-like appearance to the plastic cutlery article, to simulate genuine metal cutlery, said thickness being less than about 2000 nanometers and wherein said thin metallic coating is deposited by a vacuum deposition process.

(Reexamination Certificate, '542 patent, 1:25-1:44). Dependent claims 3, 35 and 12 narrow this claim by adding limitations requiring that the coating be less than “1000 nanometers in thickness,” “about 200 nanometers in thickness” and that the vacuum deposition process be “sputtering deposition” respectively. Claim 38 is similar to claim 1 except that: (1) it does not require the metallic coating to be “suitable for food contact”; but (2) does require that it be produced “without an overcoat.” An overcoat is a plastic coating deposited on top of the metal layer to act as a barrier between food and the metal layer.

Claim 25, the only claim asserted against Sabert’s titanium cutlery, claims “a cutlery article for handling and consuming food, comprising[:]

a light transmitting plastic material and having a plurality of surfaces, wherein at least one surface amongst said plurality of surfaces is deposited with a thin metal layer suitable for food contact without an overcoat;

said thin metal layer being deposited by a sputter deposition process,

¹ An overcoat is a plastic coating deposited on top of the metal layer to act as a barrier between food and the metal layer.

whereby a reflective metal-like appearance is imparted to at least a portion of said cutlery article, and said thin metal layer being less than about 2000 nanometers.

(Reexam Certificate at 2:44-54). This claim differs from claim 1 primarily in that it does not require the metal to be steel or stainless steel but does require the use of a “light transmitting plastic material.”

A. The Parties’ Contentions

WNA contended that Sabert’s steel and titanium products infringed many of the claims of its patent. Most relevantly, WNA argued that Sabert’s product infringed claim 25, despite the fact that Sabert’s underlying plastic cutlery item was opaque, because it was made out of polystyrene. Polystyrene is light transmitting, and Sabert’s underlying substrate is opaque because it adds “regrind” (essentially black recycled polystyrene) to the virgin polystyrene. Thus, WNA alleged that the “material” itself was clear even if the substrate was opaque.

Sabert contended that WNA’s claims were invalid for a variety of reasons. In addition to alleging the claims were invalid based on lack of written description and indefiniteness, Sabert argued that the claims were invalid because they were obvious. Sabert’s closest prior art reference was a product produced by Spir-It. The Spir-It products were plastic cutlery items with a thin coating of aluminum deposited by thermal vapor deposition and covered with an overcoat. Sabert maintained that this prior art reference, combined with several other references, made the case for obviousness. Sabert also contended that the claims were unenforceable based on WNA’s inequitable conduct before the patent office.

B. The Court's Rulings

Prior to trial, the Court made several rulings in favor of WNA. First, early on, the Court granted WNA's motion to dismiss Sabert's assertion of unenforceability based on inequitable conduct. Second, when the Court construed the claims, it rejected Sabert's primary indefiniteness argument and adopted Plaintiff's construction of the term "a thin metallic layer . . . without an overcoat." (Doc. No. 113). In doing so, the Court refused to adopt Sabert's proposed construction that the term be limited to the metals specifically set forth in the specification. (*See* Doc. Nos. 56-1, 56-2 at 16-17).

Third, the Court granted WNA's motion for summary judgment that Sabert's steel cutlery infringed the patent and rejected one of Sabert's theories of invalidity as a matter of law. Fourth, the Court granted several of WNA's motions *in limine*, including, most importantly, WNA's motion to exclude the results of several foreign decisions that found that similar patents in those foreign countries were invalid. (Doc. No. 185; Doc. No. 188 at 70-72). Finally, because Mr. Sutton, Sabert's counsel, had again attempted to include allegations of his dismissed inequitable conduct claim, the Court struck those portions of the Proposed Final Pretrial Order.

C. Misconduct

The parties tried the case to a jury over a two-week period. During the case, Mr. Sutton and Sabert's witnesses repeatedly disregarded the orders and rulings set forth above, brought in improper evidence, made numerous arguments that were contrary to the law, denigrated the presumption of validity, and substituted leading questions for the testimony of Sabert's witnesses. Specifically:

- The Court excluded evidence that foreign tribunals had found the patent invalid because they were irrelevant and substantially prejudicial. The Court did so in a motion *in limine* and in several subsequent rulings during the trial. (Doc. Nos. 188 at 69-71, 185 at 2; 3/31/11 AM Sidebar tr. at 3-5). However, Mr. Sutton and a witness for Sabert

disregarded these rulings and put the evidence before the jury. (*See* 3/31/11 AM tr. at 86-88, 138-139).

- The Court dismissed Sabert’s inequitable conduct claim on the pleadings and reinforced this decision in pretrial hearings. (Doc. No. 99 at 9-15; 3/17/11 Pretrial tr. at 71; 3/21/11 Pretrial tr. at 62-65). However, Mr. Sutton and witnesses for Sabert made repeated references to WNA “misleading” the PTO before the jury, which encouraged the jury to disregard the merits of the case and punish WNA for such conduct. (*See, e.g.*, 4/4/11 Am tr. at 15-16, 24; 4/5/11 PM tr. at 43).
- The Court ruled in its *Markman* Order and several times during the trial that the word “metal” covered titanium. (Doc. Nos. 113, 3/28/11 PM tr. at 5-8; 3/29/11 AM Sidebars tr. at 1-4). Despite such rulings, Mr. Sutton repeatedly made the noninfringement argument that titanium was not covered by the term “metal” because it was not one of the metals specifically mentioned in the patent. (*See* 3/28/11 AM tr. at 61, 63, 65-66; 3/29/11 AM tr. at 126-27; 3/29/11 PM tr. at 58-59; 4/5/11 PM tr. at 46-47).
- Mr. Sutton used a visual aid during his closing with a clear expression of his personal opinion of the merits of the case.
- Despite repeated objections, which were sustained, and several instructions from the Court, Mr. Sutton put on the majority of Sabert’s case using leading questions. (*See, e.g.*, 3/31/11 PM tr. at 17-33, 37-40, 49-51, 104-115, 116-122, 4/1/11 AM tr. at 17-21).
- Mr. Sutton repeatedly argued that the presumption of validity did not apply in this case because there was prior art that the PTO did not consider. (*See, e.g.*, 3/28/11 AM tr. at 55-56).

After this conduct, which when combined occurred almost constantly throughout the trial, the jury returned an inconsistent verdict on lack of written description. The verdict also found that Sabert’s titanium cutlery did not infringe the patent and that all of the claims were obvious.

II. DISCUSSION – MOTION FOR A NEW TRIAL

Mr. Sutton’s conduct, in aggregate, created a reasonable probability that the jury was influenced by Mr. Sutton’s improper conduct. While no party is entitled to a perfect trial, all parties before this Court are entitled to a fair trial. WNA did not receive a fair trial and thus, the

Court must order the case to be retried. However, as discussed in Section III, the Court determines that absent such misconduct, the jury could have reasonably found in favor of either party on the issues of obviousness and the infringement of the titanium cutlery. Thus, except with respect to written description, the Court denies that motion.

A. Standard Of Review

Motions for new trials are governed by Federal Rule of Civil Procedure 59(a), which provides in pertinent part:

The court may, on motion, grant a new trial on some or all of the issues . . . for any reason for which a new trial has heretofore been granted in an action at law in federal court[.]

Several reasons justify granting a new trial, including: (1) when the jury's verdict is against the clear weight of the evidence and a new trial must be granted to prevent a miscarriage of justice, *Roebuck v. Drexel Univ.*, 852 F.2d 715, 717 (3d Cir. 1988); (2) when the verdict is internally inconsistent, *Malley-Duff & Assocs., Inc. v. Crown Life Ins. Co.*, 734 F.2d 133, 145 (3d Cir. 1984); and (3) when prevailing counsel committed misconduct and there is a “reasonabl[e] probabl[ity] that the verdict was influenced by prejudicial statements,” *Greenleaf v. Garlock, Inc.*, 174 F.3d 352, 366 (3d Cir. 1999).²

The Third Circuit reviews a trial court’s decision on a motion for new trial for abuse of discretion. *Montgomery County v. Microvote Corp.*, 320 F.3d 440, 445 (3d Cir. 2003). The discretion afforded to a trial court is particularly broad when the motion is based upon the misconduct of counsel because “in matters of trial procedure the trial judge . . . is in a far better position than [an appellate court] to appraise the effect of the improper argument of counsel.” *Greenleaf*, 174 F.3d at 366 (internal quotations omitted).

²The Federal Circuit applies the law of the regional circuit in matters of procedure. *Exergen Corp. v. Wal-Mart Stores, Inc.*, 575 F.3d 1312, 1318 (Fed. Cir 2009).

Where a motion alleges that the jury's verdict was against the clear weight of the evidence, the Court need not make all inferences in favor of the prevailing party. Indeed, there are situations where a judgment *non obstante veredicto* ("J.N.O.V") would be inappropriate but granting a new trial is within the discretion of the district court. *Fineman v. Armstrong World Indus. Inc.*, 980 F.2d 171, 211-212 (3d Cir. 1992).

B. Analysis

In exercising its discretion on this matter, the Court determines that a new trial is required based upon the transgressions of Sabert's counsel. While zealous advocacy can sometimes lead to minor misconduct that would not warrant a new trial, in this case the Court determines that the repeated misconduct of Sabert's counsel on a wide variety of fronts requires a new trial, particularly in light of the jury's inconsistent verdict. Prior to explaining the misconduct of Sabert's counsel, the Court notes that because of the repeated nature of Mr. Sutton's conduct, the Court can hardly assign blame to counsel for WNA for failing to object in every instance.

1. The Failure to Object and the Court's Curative Instructions Did Not Cure Prejudice from the Misconduct of Counsel.

Generally, individual elements of misconduct of counsel are insufficient to justify a new trial where they are not objected to or where the Court gives a curative instruction upon the request of counsel. In such cases, objections are either waived or juries are presumed to have followed the instructions of the Court. *Wilson v. Vermont Castings, Inc.*, 170 F.3d 391 (3d Cir.1991); *U.S. v. Riley*, 621 F.3d 312 (3d Cir. 2010). However, in cases where the misconduct at issue is substantial or repeated, such as this one, a new trial is warranted even if opposing counsel does not object to every single violation. *See Draper v. Airco, Inc.*, 580 F.2d 91 (3d Cir. 1978) (finding a closing prejudicial despite a curative instruction where there were several

violations including improper references to defendant's wealth, personal opinion of the justness of the cause of action, and referring to information not in evidence); *Kiewit Sons' Co.*, 624 F.2d 749, 758-59 (6th Cir. 1980) (ordering a new trial despite the fact that the Court repeatedly gave curative instructions). In instances where misconduct is constant and repeated, counsel cannot object to every transgression – there are simply too many transgressions. Indeed, such constant misconduct puts opposing counsel in lose-lose situation requiring counsel to either object and be seen as combative, or allow the misconduct to continue. *See Straub v. Reading Co.*, 220 F.2d 177, 181 (3d Cir. 1955).

In this case, as mapped below, Mr. Sutton's misconduct was so constant and repeated that if WNA had objected to every issue, the stream of objections would have ground the proceeding to a halt, and given the jury the impression that counsel for WNA was angry, combative, and attempting to keep relevant evidence from it. Thus, counsel for WNA can hardly be faulted for failing to object to the thirtieth transgression of the day at trial. Indeed, the Court notes that WNA likely erred on the side of objecting frequently, so frequently that its proper objections likely prejudiced its position with the jury.

3. *Misconduct*

In this case, Sabert's counsel, Mr. Sutton, committed misconduct at trial that, when taken together created a reasonable probability that the verdict was influenced by the improper statements. *See Greenleaf v. Garlock, Inc.*, 174 F.3d 352, 366 (3d Cir. 1999). Sabert's counsel and witnesses put before the jury prejudicial evidence of foreign decisions invalidating the patent, made unwarranted accusations of misrepresentations by WNA to the PTO despite the fact that the court dismissed Sabert's inequitable conduct claims, Mr. Sutton gave his personal convictions about the merits of the case, argued that there was no presumption of validity,

repeatedly disobeyed the rules against leading friendly witnesses, and improperly argued that titanium was not covered by claim 25's use of the word "metal." Each of these issues will be discussed in turn, and when taken together, the Court determines that there was a reasonable probability that the jury was influenced by the improper conduct of Mr. Sutton and Sabert's witnesses.

The violations were egregious and they were made far worse by the fact that in committing these violations Mr. Sutton repeatedly ignored the Court's rulings. The Court has seldom had an attorney before it who had as much difficulty following the Court's orders and rulings. A trial is not the Old West. There are rules, and attorneys are expected to follow them. The Court cannot reward a litigant who manifestly disregards those rules and express rulings of the Court based on either the effectiveness of opposing counsel or the proper instructions of this Court.

a. Sabert's Counsel and Witness Improperly Introduced Evidence of Foreign Proceedings that Invalidated WNA's Foreign Patents

Sabert's amended answer in this case included allegations about two foreign proceedings finding similar claims in foreign patents invalid for lack of inventiveness. (Doc. No. 18 at 35-36). To prevent the introduction of this evidence, WNA filed a motion *in limine* to exclude testimony about foreign decisions, which the Court granted. (Doc. No. 185 at 2; 3/21/11 Pretrial tr. at 69-71). Mr. Sutton stated that his only reason for seeking their admission was that the jury might be aided in its obviousness determination by knowing another country applied similar law to a similar patent to find the invention was invalid. (3/21/11 Pretrial tr. at 69-71). The Court concluded that because the decisions involved different laws and different patents, they were not relevant to this proceeding and that there would be substantial prejudice if these decisions were

admitted. (*Id.*). The Court granted the motion to exclude the proceedings without any relevant exceptions.³ (Doc. No. 185 at 2). The Court was not equivocal in its decision.

Nonetheless, without raising this issue again with the Court, Mr. Sutton and his witness, Mr. Salama, introduced this extremely prejudicial evidence to the jury. Specifically, when Mr. Sutton asked Mr. Salama about the information he relied upon to decide to produce the cutlery in the face of WNA's patent, he responded:

A: Well, as was mentioned, I think early on in the lawsuit there was other legal proceedings taking place in China and in Europe –

(3/31/11 AM tr. at 86). WNA objected and the Court sustained the objection. However, counsel continued to pursue this line of questioning and asked about the European proceedings.

Sabert's new theory, which it did not present to the Court prior to eliciting this testimony, was that the proceedings were relevant to whether Sabert willfully violated the patent -- it would not have done so willfully if it believed in good faith that the patent was invalid. Essentially, Mr. Sutton's argument was that the fact that Sabert thought the results would be the same in the United States, would suggest it did not willfully violate the patent. Before there were any other substantive answers, the Court granted a sidebar and made unequivocally clear that the content and outcome of the foreign proceedings would not be admitted *even for the purpose of Mr.*

Salama's state of mind:

THE COURT: The problem with the foreign ones and why I've sustained the objection on that is, it really seems to be very much 403 --

MR. MENTLIK: Yes, Your Honor.

THE COURT: -- any relevance, which doesn't seem to be there, would be overwhelmed by confusion, the delay and all the rest of it. So that's out.

MR. MENTLIK: But the --

MR. SUTTON: (Indiscernible) state of mind.

³ The Court did agree to leave open the question of whether the *statements* made by the parties in those proceedings would be admissible. (3/21/11 AM Pretrial tr. at 70:23-71:1). However, the Court never left open the question of whether the conclusions of the foreign decisions would be admissible. (*Id.* at 71).

THE COURT: **Well, we're not going to bring it in for the state of mind.** I mean, the whole thing is what's going on in some foreign proceeding with different claims, different issues, et cetera.

MR. MENTLIK: Exactly, Your Honor.

THE COURT: We'll be here forever on irrelevancies.

MR. MENTLIK: And my concern is that now the jury thinks I'm trying to keep something from them.

THE COURT: No.

MR. MENTLIK: So I think it needs to be cleared up.

MR. SUTTON: Your Honor, I just want to ask the question, was there a foreign proceeding and did you rely on, without asking him the outcome, was there a foreign proceeding, did you get other legal advice from those attorneys?

THE COURT: **How is a foreign proceeding going to invalidate the U.S. patent?**

MR. SUTTON: It's not invalidated. It goes to whether he was willfully infringing.

THE COURT: **Sustain the objection. Foreign proceeding is not going to invalidate a U.S. patent, end of story.**

(3/31/11 AM Sidebar tr. at 3-5) (emphasis added).⁴

Even though the Court had sustained the objection and specifically told Mr. Sutton he could not pursue this testimony *even to put forth state of mind testimony*, Mr. Sutton continued his line of questioning in a way that suggested to the jury that the Court and Mr. Mentlik were keeping important information from it:

Q. Okay, Mr. Salama, without going into details in the foreign countries, were there other events occurring in those foreign countries that you relied on in deciding to go forward with making the product in the United States?

A. You mean selling the product?

Q. Yes.

A. Yes, of course. As I mentioned earlier --

Q. Well, I'm afraid we can't get into that too deeply. But you did rely on these other proceedings, correct?

A. I did.

Q. Let me ask you a more specific question so we -- and did you rely on foreign counsel in those countries as to the validity of the WNA patent?

A. Yes, we did.

Q. And based on their decisions you decided to go forward with selling in the United States?

A. In 2009, yes.

⁴ The Court did initially entertain this new theory, (3/31/11 AM tr. at 86-87), but at the sidebar quoted above made a definitive ruling against Mr. Sutton.

(3/31/11 AM tr. at 87-88). This exchange strongly implied that Sabert had prevailed in the foreign proceedings. Such an implication was prejudicial to Waddington as it encouraged the jury to conclude that if other jurisdictions had found the patent invalid, the jury should as well.

Far more egregious than this question was that, despite knowing that it was a forbidden subject, Mr. Salama purposely put the evidence before the jury several times even after the Court had sustained Mr. Mentlik's objections:

Q. So what is your belief -- what was your state of mind in 2009 regarding infringement?

A. Well, as I said earlier there were a lot of -- there was a lot of information that we reviewed already, that we believed, **and we had also prevailed in other countries** --

MR. MENTLIK: Your Honor?

THE COURT: **Sustained.**

A. -- and we, you know --

MR. MENTLIK: Objection.

THE COURT: **Sustained, as to other countries. I've ruled on that.**

MR. MENTLIK: Move to strike the testimony.

A. Well, you know, it was my state of my mind then that **because we had prevailed in other countries** --

MR. MENTLIK: Your Honor?

A. -- **that we would prevail in the U.S.**

MR. MENTLIK: Your Honor --

A. It's -- it was my --

MR. MENTLIK: -- the witness is in my view Your Honor, avoiding --

THE WITNESS: Mr. Sutton asked me an open-ended question and I'm answering the question.

THE COURT: I've ruled on the foreign proceedings. All right, as far as it goes to your state of mind, you felt that you would prevail, right? That's all.

THE WITNESS: That's correct.

THE COURT: Okay.

(3/31/11 AM tr. at 138-39) (emphasis added). This exchange was egregious and grossly prejudicial to WNA.

While Sabert attempts to characterize the Court's last statement as a ruling in its favor, this misrepresents the sequence of events. The Court twice sustained the objection, and it was only after Mr. Salama purposely injected the improper testimony that the Court tried to place the testimony in its proper light before the jury. At that point, the Court was in a difficult situation: the cat was out of the bag and the Court had to place the testimony in context without it looking as if the Court and Mr. Mentlik were purposely concealing important evidence from the jury. The Court did the same with its attempted curative instruction. (3/31/11 AM tr. at 140). In sum, the Court made these statements in reaction to the improper testimony; they were not rulings in favor of Sabert.

The prejudice from this testimony is substantial. The testimony encouraged the jury to abdicate its responsibility to decide the question of the U.S. Patent's validity under U.S. law and conclude that if other jurisdictions had found foreign patents invalid, it also should find the U.S. patent invalid. However, such an action would have been wholly improper -- U.S. patent law is distinct from foreign patent law, and the patent itself is a different from its foreign counterparts. In sum, except to the extent that it prejudicially suggests that the jury should follow the foreign decisions, the conclusions of those decisions have absolutely no relevance to liability. *In re Dulberg*, 472 F.2d 1394, 1398 (C.C.P.A. 1973) (patent rights in foreign countries have no relevance to United States Patents); *see also Windsurfing Intern'l, Inc. v. Fred Ostermann GmbH*, 668 F. Supp. 812 (S.D.N.Y. 1987) (noting that foreign decisions were properly held irrelevant during the liability phase of the trial). This prejudice was made worse by the fact that, because WNA had prevailed pretrial on this issue, it was not able prepare contrary evidence of foreign proceedings in which WNA prevailed.

Moreover, the way in which Mr. Sutton and Mr. Salama presented this excluded evidence to the jury made it even more prejudicial. Mr. Salama forced the issue on the jury despite WNA's objections and the Court's repeated sustaining of those objections. (3/31/11 AM tr. at 138-39). This allowed Sabert to feign victimhood in front of the jury, and it is probable that the jury left with the impression that the Court and Plaintiff's counsel were conspiring to keep important evidence from it. In addition, Mr. Salama cannot reasonably assert that he did not purposely put such evidence before the jury – he knew and heard that an objection was pending and sustained—but chose to essentially shout his conclusions to the jury and argue with the Court. The actions of Sabert's counsel and Mr. Salama were in contempt of this Court's express rulings.⁵

The competence of WNA's counsel in responding to this grossly improper information is irrelevant and misses the point. The results of the foreign decisions should not have been before the jury in the first place – the Court repeatedly excluded the evidence for *all purposes*. Counsel for WNA should not have had to try to play “damage control” with this testimony. The testimony was excluded because that “damage control” was likely to fail, and the prejudice of the testimony – in encouraging the jury to exclusively rely on irrelevant evidence – was likely to remain.

This improper conduct of Sabert alone makes a strong case for a new trial. Despite the Court's proper instructions, the Court was hamstrung in its ability to correct the prejudice by the

⁵ The cases cited by Sabert do not convince the Court otherwise. Sabert cites two cases suggesting that foreign decisions are relevant to willfulness, but these cases do not suggest that the relevance of the foreign decisions to willfulness is not substantially outweighed by unfair prejudice to the liability phase of a jury trial. *See Windsurfing Int'l*, 668 F. Supp. 812; *Pfizer Inc. v. Teva Pharm. USA, Inc.*, No. 04-754, 2006 WL 3041102 (D.N.J Oct. 26, 2006). Thus, the cases do not undermine the Court's ruling excluding them under Federal Rule of Evidence 403. In addition, Sabert had the opportunity to present these cases at the motion *in limine* or prior to asking questions it knew would elicit improper answers. Sabert did neither; rather, it put the foreign proceedings before the jury in a way that maximized the unfair prejudice to WNA. In sum, Sabert's introduction of the foreign proceedings was improper and extremely prejudicial.

way in which Sabert had presented the evidence. Thus, there is a reasonable likelihood that they influenced the jury's verdict. *See Greenleaf v. Garlock, Inc.*, 174 F.3d at 366. On retrial, Sabert's counsel and witness shall *not* repeat this misconduct. Any reference to foreign proceedings will be immediately sanctioned. Depending on the severity of the infractions, sanctions may include contempt of court or the entry of judgment against Sabert. Counsel has been warned.

b. Sabert Made Extremely Prejudicial Accusations of Inequitable Conduct Despite the Court Having Dismissed that Element of the Case

Where no inequitable conduct claim exists in a case, it is improper for a party or the Court to cast aspersions on the validity of the patent based upon improprieties in the prosecution of the patent. Indeed, in *Norian Corp. v. Stryker Corp.*, 363 F.3d 1321 (Fed. Cir. 2004), the Federal Circuit found that flawed arguments made by the patentee in prosecution were irrelevant to patent validity if inequitable conduct had been dismissed.⁶ The reason behind this strict proscription is clear – evidence of improper conduct before the PTO, where such is not part of the case, is likely to encourage the jury to punish the perceived offender instead of passing on the merits of invalidity.

On September 29, 2010, almost *six months* before trial, this Court dismissed Sabert's inequitable conduct claims under Federal Rule of Civil Procedure 9(b) because they did not meet the heightened pleading standard required by inequitable conduct. (Doc. No. 99 at 9-15). Sabert thus had more than ample time to prepare its case without allegations of inequitable conduct.

⁶ While the *Norian* court ultimately found the trial court had not abused its discretion in refusing to grant a new trial because counsel failed to object to the flawed jury instruction, that does not undermine the fact that the evidence is improper. *Id.* at 1329; *see also Aristocrat Technologies Australia PTY Ltd. v. Intern. Game Technology*, 543 F.3d 657, 663 (Fed. Cir. 2008) (irregularities in prosecution relevant only to unenforceability for inequitable conduct, not invalidity, where they only serve to distract from the real issues at hand); *Magnivision, Inc. v. Bonneau Co.*, 115 F.3d 956 (Fed. Cir. 1997) (same).

Nonetheless, during the Final Pretrial Conference it became clear that Sabert had included these allegations in the Proposed Final Pretrial Order. Sabert's counsel suggested that such allegations related to a "duty of candor" in connection with commercial success, a theory that is invalid as a matter of law. *See Norian*, 363 F.3d at 1328-1329 (even alleged misstatements to the patent office are only relevant to inequitable conduct and are irrelevant and prejudicial on the issue of validity). The Court clearly rejected Sabert's contentions as follows:

THE COURT: Commercial success, you can raise. **But anything about duty of candor or--**

MR. SUTTON: Well--

THE COURT: --**misleading the Patent Office, you cannot.** All Right? That makes it fairly simple.

(3/17/11 Pretrial tr. at 71) (emphasis added). When the pretrial conference continued on March 21, 2011, Mr. Sutton raised this issue a third time, but the Court reinforced this ruling in forceful language. (3/21/11 Pretrial tr. at 62-65). Thus, the Court, on *three separate occasions* informed Sabert that it would not be able to make any allegations about inequitable conduct or violating the duty of candor.

Nonetheless, Sabert's counsel and witnesses repeatedly referred to inequitable conduct arguments. First, Darryl Nazareth elaborated, in an answer to a simple yes or no question, that the patent "issued because the Patent Office was led [by WNA] to believe that aluminum was toxic, and that is a misrepresentation of the facts."⁷ (4/4/11 AM tr. at 24). While WNA failed to move to strike this testimony, WNA had recently objected several times to Mr. Sutton using Mr. Nazareth, a fact witness, as an expert. These objections were sustained. (4/4/11 AM tr. at 15-16). Further, Mr. Nazareth gave the answer as an unexpected elaboration to a simple yes or no question. As mentioned, WNA's counsel could not object to every impropriety without

⁷ While question of whether the aluminum was toxic was legitimately before the jury as it determined how many limitations of the claims the Spir-It prior art contained, the implication that WNA's statement was an intentional misrepresentation of the facts was inappropriate.

appearing combative and as if it were trying to hide information from jury. *See City of Cleveland v. Peter Straub v. Reading Co.*, 200 F.2d 177 (3d Cir. 1955).

Mr. Nazareth's statements were not the only situation where Sabert made improper reference to inequitable conduct. Despite *three rulings* against it, Mr. Sutton again cast aspersions in his closing that the patentee purposely failed to disclose important information to the patent office, which in his view should have undermined the validity of the patent:

But, again, they -- the examiner -- I didn't see any evidence in this case where the examiner was told. I didn't see any evidence in the file where the examiner was actually told that [WNA] had a great machine that we were using to make it very cheaply and that may have been the reason for the commercial success and that's why we sold millions of pieces

(4/5/11 PM tr. at 43). First, this statement improperly suggested that WNA hoodwinked the patent agent. Second, and more importantly, this statement is patently false. WNA twice provided this information to the PTO examiner in a declaration from Donald Mattox, which WNA submitted at Sabert's request.⁸

Not only did these statements suggest that WNA had committed inequitable conduct, a claim that was dismissed from the case six months prior to trial, but they also miscast the facts. Thus, there is no question that these statements were prejudicial – allegations of improper conduct before the patent office are excluded from non-inequitable conduct cases because they encourage a jury to discard the presumption of validity and the merits of the invention and punish the patentee for its supposed misconduct before the PTO. In this case, these statements contributed substantially to the possibility that the jury was influenced by improper considerations.

⁸ Sabert's argument that WNA did not submit this information in the prosecution of the original patent is irrelevant because the trial examined only the claims of the reexamined patent.

In the new trial, Mr. Sutton and Sabert's witnesses shall not make arguments about the lack of disclosure or the intentional misleading of the PTO on the toxicity of aluminum. Sabert may argue that aluminum is nontoxic to support its position that the Spir-It prior art makes an obviousness case. However, Sabert may not allege that the contrary statement made to the PTO was intentionally misleading. The Court realizes that this is a fine line to toe, but Sabert must toe it. If Sabert fails to do so, the Court will impose sanctions.

c. Sabert Improperly Argued That Titanium Is Not Covered by Claim 25

Mr. Sutton's persistent argument that titanium is not covered by Claim 25 was improper and the Court, in its discretion, determines that it was confusing to the jury. It was an improper attempt to revise this Court's construction of claim terms.

In this Court's claim construction proceedings, Sabert proposed a construction that would have limited the term "metal" to "silver, steel, stainless steel, chromium, aluminum, copper, and gold." (Doc. Nos. 56-2 at 17, 56-1 at 8). This Court entered a *Markman* order that rejected Sabert's proposed construction (Doc. No. 113) based upon the plain meaning of the term "metal," which is open to every metal, not just those listed, and the fact that the description of embodiments in the specification does not limit the scope of the claims of the patent.

Despite this clear ruling in the *Markman* order, Mr. Sutton continued to argue and elicit testimony that Sabert's titanium-coated products did not infringe Claim 25 because they utilized titanium and the patent was limited to the seven metals specifically listed in the patent. This was in direct contradiction of the *Markman* order.

Specifically, Mr. Sutton harped on this improper and prejudicial theory in his opening and made it a major theme:

Now, going back to Claim 25, this claim is different than Claim 1 which you will be considering, as well, and it says a thin metal layer to be coated onto the plastic. It doesn't say – it's not limited to stainless steel. And in this claim, WNA has taken the position that Sabert is infringing that claim even with titanium which is never mentioned in their patent, but Sabert has switched over from stainless steel to titanium coating to avoid a problem. So, now they say, well, our patent also covers titanium, **even though they never mentioned it in the patent, and there will be a lot of discussion about that, that they reduced their seven metals** that they originally disclosed down to two metals, steel and stainless steel, and that although they reduced from seven to two, they're now saying, well, we think our patent also covers titanium, even though we never mentioned it.

(3/28/11 AM tr. at 61) (emphasis added).

To avoid a problem, Sabert changed from coating its product with stainless steel. They changed over to titanium **because it was not mentioned in the patent.**

(3/28/11 AM tr. at 63) (emphasis added).

There is another reason why Sabert's titanium coated plastic cutlery *does not infringe*, because it is never mentioned or disclosed in the original patent or the revised patent. Secondly, WNA's patent listed seven different metals right in the body of the patent that could be used. The seven metals are aluminum, stainless steel, gold, silver, chromium, or copper, and I think the other one is not just stainless steel but steel. So, they had seven metals disclosed in their written write-up of the patent originally and the patent never mentioned or disclosed titanium.

(3/28/11 AM tr. at 63).

Now, after Sabert changed from stainless steel to titanium in 2010 to try and avoid a problem with WNA, WNA then decided in late 2010 that its original patent that it filed in 2002 with these seven metals that I mentioned earlier, all of a sudden they said, well, it also covers titanium. You switched to titanium to avoid a problem? Well, guess what. **We think our patent also covers titanium, even though it was never mentioned in the patent.** And you'll hear from Mr. Vergason a lot of statements from the original arguments to the Patent Office during the three years when they were doing the re-examination to get the second patent, where they never talked about any other metals and, in fact, they were reducing the number of metals and not increasing the number of metals. And **it's very simple that the public and Sabert have a right to know what a patent covers from the time it's granted**, and it should not be a moving target that changes. Therefore, the evidence will show the jury that WNA has no basis for adding titanium to its patent when WNA never

disclosed it in 2002 and when Sabert changed to titanium in 2010, Sabert reasonably believed and relied on what they saw in the patent and it did not mention titanium.

(*Id.* at 65-66) (emphasis added).

This argument had utterly no basis in the Court's claim construction. When Mr. Mentlik mentioned the issue during the break, Mr. Sutton claimed that the issue had not been decided by because the titanium cutlery was not an allegedly infringing item at the time of claim construction.

However, Mr. Sutton's claims were incorrect. While the titanium cutlery had not been alleged infringing,⁹ the question of what "metal" meant was at issue. On the claim construction chart for "a thin metal layer suitable for food contact without an overcoat," in claim 25, in addition to alleging indefiniteness, Sabert proposed that the "a thin metal layer . . . without an overcoat" portion should be construed as "There is no overcoat on a thin metal layer, *which is a metal selected from the group consisting of silver, steel, stainless steel, chromium, aluminum, copper and gold.*" (Doc. Nos. 56-2 at 17, 56-1 at 8). The Court declined to adopt this construction that limited "metal" to those metals specifically enumerated in the specification, and indeed, adopted the Plaintiff's construction, which was open to all metals.

Thus, Mr. Sutton knew his construction had been rejected and that the term "metal" was not limited to the metals specifically listed in the specification.¹⁰ However, without batting an eyelash, he made this rejected and improper noninfringement argument to the jury.

⁹ The allegation towards the titanium cutlery is in most ways irrelevant, as construction is based on the intrinsic evidence, not the allegedly infringing device.

¹⁰ The Court acknowledges that Sabert raised this issue again in his summary judgment briefs and that the Court did not expressly address the question because it found an issue of material fact based on another limitation. However, that does not undermine the original construction's clear rejection of Sabert's position or Mr. Sutton's obligation to request supplemental claim construction prior to presenting this issue of law to the jury.

The issue was extensively discussed between counsel and the Court after the opening in the absence of the jury. The Court categorically rejected Mr. Sutton's argument and reminded him that:

[THE COURT:] it is for the Court to define claim terms using primarily intrinsic evidence, the patent itself and where helpful the prosecution history.

(3/28/11 PM tr. at 5). On the merits of the claim construction, the Court expressly rejected Mr. Sutton's position and referred the parties to the periodic table to help define metal. The Court closed the matter by stating that "I understand your position. I've dealt with it. **Your exception's noted.**" (3/28/11 PM tr. at 7) (emphasis added). Mr. Sutton could not have left the conference believing that he was still able to argue that "metal" did not cover titanium, but amazingly he attempted to argue it anyway.

Despite the Court's rejection, Mr. Sutton sought to re-submit the argument during a break, and the Court again rejected it:

MR. SUTTON: No. By limiting it to four out of the seven they thereby implicitly excluded titanium.

THE COURT: I've heard your position. It's been argued before. **I rule otherwise.**

(3/28/11 PM tr. at 8:12-15) (emphasis added). The Court now had ruled *three times* that metal included titanium. There could have been no question that Mr. Sutton's argument was precluded.

However, despite *three* rulings on the subject, Mr. Sutton again demonstrated his manifest disregard for this Court's rulings by repeatedly bringing up this issue. The next morning he engaged in the following cross examination of a witness of WNA that put this improper and prejudicial theory before the jury yet again:

Q Now at the time in 2001 and two when you were working on developing your product --

A Yes.

Q -- did you consider using titanium?

A No, we did not.

Q Now in the summary of invention of your patent application I want you to read -- I would like to read a sentence to you. "Yet a further object of the invention is the metalized plastic food service item wherein the thin metallic coating is **comprised of a metal selected from the group consisting of silver, steel, stainless steel, chromium, aluminum, copper, and gold.**" And I'm reading from an argument you made to -- excuse me -- I'm reading from your patent. **So there again are the seven metals that we talked about earlier, right?**

A I'm not sure where you are reading from but --

Q It's from the objects of --

A -- I think that you are --

Q -- it's from the objects of -- excuse me -- from the summary of the invention in the patent. **I just read you a sentence that says the thin metallic coating is comprised of a metal selected from the group consisting of and then it has the seven metals.**

A Okay.

Q So that was stated in your patent, correct?

A Yes.

Q **And you only stated those seven, correct?**

A Yes. We identified those seven specific metals, yes.

Q **And then as we said earlier in Claim 2 you list the seven metals in the form of a Markush group of seven metals, right?**

A **In Claim 2, yes.**

Q **And you agreed with me earlier, without going through it all over again, that that is a Markush type of claim and it's a closed end type of claim listing seven metals, right?**

A Yes.

Q **And you did not include titanium in that list.**

A **That is correct.**

Q So you --

MR. MENTLIK: Your Honor, may we have a sidebar?

(3/29/11 AM tr. at 126-27). At the sidebar, the Court made yet a *fourth* ruling:

THE COURT: Yes.

MR. MENTLIK: Your Honor, [] you ruled yesterday that the way you're going to construe Claim 25 is that it's not limited to any particular metal. Mr. Sutton is clearly in my view trying to --

THE COURT: Is that where we're going?

MR. SUTTON: No, I didn't hear you make a ruling on that.

MR. MENTLIK: I thought you --

MR. SUTTON: We discussed it.
MR. MENTLIK: -- I thought you made it pretty clear, Your Honor.
THE COURT: I thought I did too.
MR. MENTLIK: I thought your words were periodic table and that Mr. Sutton
--
THE COURT: Yes, I did. I mean I --
MR. MENTLIK: It seems to me --
THE COURT: **I was 100 percent clear on that one. Absolutely.**
MR. MENTLIK: (Indiscernible).
THE COURT: Yes, I was. Look at the transcript if you want to.
MR. MENTLIK: It seems to me that the --
THE COURT: As a matter of fact if you want to -- go ahead.
MR. MENTLIK: -- it seems to me that what Mr. Sutton is trying to do is argue
exactly what you ruled on --
THE COURT: **Precisely.**
MR. MENTLIK: -- and trying to get the jury to (indiscernible).
MR. SUTTON: I thought we were conferring and I didn't think (indiscernible).
THE COURT: I considered it and then I came back **and I ruled.**
MR. MENTLIK: And he's trying to get the jury to believe that titanium is
excluded.
THE COURT: If you want to get a transcript fine, but I recall that.
MR. SUTTON: So you're saying that titanium is covered by that claim?
THE COURT: I'm saying that metal means metal unless you can find
something in prosecution history otherwise it was for me to decide, not for the
jury to decide and I decided it, all right?
MR. SUTTON: **Okay. But, Your Honor, I was hoping to put on the
evidence today which I just did that it's a closed end Markush group that
excludes other metals.**
MR. MENTLIK: **That's Claim 2.**
THE COURT: **We're talking about Claim [25] here.**
MR. MENTLIK: (Indiscernible).
THE COURT: **I've ruled on this one, all right.** Let's take the break until
2:00.

(3/29/11 AM Sidebars tr. at 1-4).

It is inconceivable to this Court how an attorney, after having been ruled against *four* times, could again raise an issue before the jury. However, Mr. Sutton again raised the issue before the jury, prompting WNA's counsel to raise objections which the Court sustained.

(3/29/11 PM tr. at 58-59; *see also* 3/31/11 PM at 50; 3/31/11 AM tr. at 56, 102-107 (arguably going to state of mind but going too far)). Mr. Sutton also repeatedly stressed the seven metals

included in a number of other contexts as well. Mr. Sutton's persistence led the Court to issue a revised *Markman* order, which stated:

xxi) "metal layer" as used in the reexamined claim 25 of the '542 patent, is not limited to only those metals specifically identified in the '542 Patent and means "any metallic coating."

(Doc. No. 244).

Mr. Sutton also pushed the issue in his closing, where he made the argument in his *infringement* section, and then attempted to pass off the argument as one addressed to willfulness. In the section of his discussion that discussed the *infringement* of claim 25, he stated that:

So they're saying, WNA is saying that somehow that creates **an infringement situation**.

So **with regard to Claim 25**, I just want to -- the last thing I want to say about it is they -- WNA has charged Sabert with **infringement** on two different products, the original product that we were making in September of '09 and that was coated with stainless steel. So since that stainless steel product had the black plastic material and a coating of stainless steel, so you could not see through it, it's not light transmitting, we do not infringe -- Sabert does not infringe with this product Claim 25. All you have to do is simple. Remember it's not light transmitting. And so that's the stainless steel coated product.

And then would be when Sabert switched over to titanium -- and by the way, you heard evidence from Mr. Salama that they switched over to titanium because when you read the patent -- and I want you to read the patent when you go in there. But I will represent to you it never says titanium as one of the seven metals that they talk about. They give a list of seven metals. They cut it down to two in the claims, steel and stainless steel. **They do have a Claim 25 that says a metal, but they were cutting down the number of metals that worked.** They said aluminum was no good, so they cut the seven metals down. They cut out aluminum, they cut out chromium, they cut out copper. They dropped -- in the claims they only have steel and stainless steel. And yet they came back and said we covered titanium.

(4/5/11 PM tr. at 46-47). At this point Mr. Sutton had only been speaking about *infringement* and there is no doubt that this discussion is improper argument against the infringement of claim

25. It is only after making these improper statements, which seemed clearly to speak to the *infringement* of claim 25, that Mr. Sutton explained how the discussion was relevant to willfulness. (*See id.*) In light of Mr. Sutton’s prior disregard for the Court’s rulings, the Court can only conclude that he intentionally put the discussion of the seven metals first – while discussing infringement and before mentioning willfulness – in order to impress upon the jury that “metal” did not cover titanium, and then only mentioned willfulness as an attempt to pass off the statement as one within the permissible scope of argument.

The Court has seldom encountered an attorney who has so much difficulty following the Court’s orders. Mr. Sutton’s actions must be interpreted as an attempt to suggest an improper basis for the jury to conclude that the titanium cutlery did not infringe the patent. Despite the Court’s curative instructions, the Court believes that this created a likelihood that the jury was influenced by the improper arguments. On retrial, Mr. Sutton shall not make such arguments unless it is abundantly clear that they are directed towards willfulness and not towards infringement. The Court will impose sanctions if Mr. Sutton strays from this path. If necessary, the Court will bifurcate the trial.

d. Sabert Employed an Improper Visual Aid During Its Lengthy Closing Argument

In addition to the above infractions, Mr Sutton used a visual aid during his closing argument that was not only improper but also prejudicial. The visual aid read:

It is my absolute conviction that after I have a chance to review the facts of the case with you and put the pieces together in a coherent and orderly fashion so that it might make more sense, you will decide in favor of Sabert on all these points.

There was no doubt that such expression of personal opinion is both improper and potentially prejudicial. The aid violated New Jersey's R.P.C. 3.4(e), which provides that an attorney shall not "in trial . . . state a personal opinion as to the justness of a cause, the credibility of a witness, [or] the culpability of a civil litigant[.]" New Jersey's Rules of Professional Conduct apply in this Court under L. Civ. R. 103.1 (a).

The Third Circuit has granted new trials in a number of cases where attorneys expressed their personal opinion to the jury when such conduct was paired with other misconduct or errors of the trial court. In *Blanche Road*, a new trial was granted, in part, due to counsel's statement that his witness "answered honestly, candidly, accurately" and was "excellent." *Blanche Road*, 57 F.3d at 264; *see also Draper v. Airco, Inc.*, 580 F.2d 91, 95-96 (3d Cir. 1978) (new trial granted, in part, because of "counsel's assertion of his personal opinion of the justness of his client's cause"); *Fineman v. Armstrong World Indus., Inc.*, 980 F.2d 171, 209 (3d Cir. 1992) (new trial granted, in part, because counsel "improperly provided his personal opinion as to the justness of his cause"). Although such cases have not granted new trials *solely* based on counsel's statements of personal opinion, it is clear that such statements constituted an important factor in the court's decision to grant a new trial. The expression of opinion played a similar role in this case, which was rife with other misconduct.

In a timely fashion, WNA's counsel objected at sidebar that Mr. Sutton's personal opinion was inappropriate. (4/5/11 PM Sidebar tr. at 2). While the Court properly instructed the jury to disregard the aid, the use of the aid was prejudicial because it was displayed for more than 80 minutes during Mr. Sutton's closing. Mr. Sutton shall not express his personal opinion of the justness of the cause on retrial.

e. Mr. Sutton Constantly Disobeyed Rules and the Court's Directions Regarding The Leading of Friendly Witnesses

Mr. Sutton's continuous disregard for this Court's instructions regarding leading questions was improper, undermined the jury's ability to determine the credibility of his witnesses, and cast opposing counsel in a negative light. Indeed, Mr. Sutton repeatedly asked leading questions of friendly witnesses, including Mr. Salama, Mr. Vergason (*see e.g.* 3/31/11 PM tr. at 20, 50) and Mr. Darryl Nazareth (4/5/11 AM tr. at 27). (*See also, e.g.*, 3/31/11 AM tr. at 104-115 (in which every question asked by Mr. Sutton for more than 10 pages is leading immediately after an objection for leading the witness); 3/31/11 AM tr. at 116-122 (where Mr. Sutton continues to lead on almost every question despite repeated objections by counsel, requiring opposing counsel to become combative)). Prompted by WNA's objections, the Court asked Mr. Sutton to stop asking leading questions:

[THE COURT]:. . . **please avoid leading.** This is your client.

(3/31/11 AM tr. at 115:21-22) (emphasis added). However, Mr. Sutton continued to ask leading questions, prompting WNA to raise numerous objections. However, the frequency of the leading questions made it effectively impossible for WNA to raise an objection after every question.

Mr. Sutton's use of only leading questions became so persistent that the Court decided that a brief explanation of the prompts that give rise to leading questions was appropriate:

[THE COURT]: Do you? Yes? No? Leading.
Non-leading, why? How? Describe?

(3/31/11 AM tr. at 121:16-17). However, Mr. Sutton continued to lead friendly witnesses despite this instruction.

Mr. Sutton's persistence in asking leading questions led this Court to order a recess later that day. The Court instructed Mr. Sutton to stop asking any further leading questions of his own witnesses, and took the time to explain to Mr. Sutton what a leading question is:

If you look at Rule 611 of the Federal Rules of Evidence, tells us leading questions should not be used on direct examination of a witness, except as may be necessary to develop the witness' testimony. Ordinarily, leading questions should be permitted on cross examination. Here, we have an adverse party. Therefore, the direct examination by the plaintiff is conducted by leading questions and the cross by the attorney of the client is by non-leading questions. A leading question is one that suggests the desired answer. When you make statements and have the witness agree or disagree with you, yes or no, **as counsel has been doing repeatedly**, that is a leading question.

Now, we don't have the sort where we allow a leading question, for example, to matters not in dispute, preliminary matters or foundations for exhibits. Therefore, please redirect your examination so that it will not be leading, and I won't have to sustain any more objections. All right?

(3/31/11 AM tr. at 123:3-19) (emphasis added). Despite this Court's clear explanation of what a leading question is and *two* firm instructions where the Court felt the need to pause the trial, Mr. Sutton continued asking leading questions to his witnesses. (*See, e.g.*, 3/31/PM tr. at 17-33, 37-40, 49-51 (where the vast majority of the questions to Sabert's primary expert are leading, causing the Court to suggest non-leading questions and prompting objections from Mr. Mentlik); 4/1/11 AM tr. at 17-21 (similar)). After a certain point, it was not possible for WNA to object on every occasion without prejudicing itself. If Mr. Mentlik had objected to every leading question, it would have ground the proceedings to a halt and caused WNA to be the object of the juror's ire, who would see his actions as intentionally slowing down the pace of the trial. Indeed, Mr. Mentlik and Mr. Kennedy objected frequently, so frequently that the jury may have come away with an opinion that they were combative and attempting to slow the trial.

While the occasional improper leading question occurs in every case, repeatedly asking leading questions of a party's own witnesses is prejudicial. Indeed, leading questions have the effect of preventing the jury from making a proper credibility determination. If a witness cannot recall the events and has difficulty answering an open-ended question, a jury is entitled to find that testimony not credible. Leading questions rob the jury of the ability to make that determination. Repeated leading questions cause witnesses to become "relatively unnecessary except as sounding boards." *Straub v. Reading Co.*, 220 F.2d, at 180. The effect is that the attorney testifies and the jury is unable to assess the credibility of the witness.

Mr. Sutton's continuous use of leading questions of his own witnesses was improper and resulted in unfair prejudice to WNA by preventing the jury from judging the credibility of his witnesses. His witnesses acted as mere sounding boards, and his persistence allowed him to cast opposing counsel as combative. This Court will not encourage such behavior and this conduct will not be repeated upon retrial. Mr. Sutton shall take the time to prepare his case *without* leading questions for his own witnesses.

f. Sabert Improperly Argued That There Was No Presumption Of Validity

Pursuant to Title 35 U.S.C §282, "[a] patent shall be presumed valid" and "[t]he burden of establishing invalidity . . . rest[s] on the party asserting such invalidity." Further, "a defendant seeking to overcome this presumption must persuade the factfinder of its invalidity defense by clear and convincing evidence." *Microsoft Corp. v. 141 Ltd. P'ship*, 564 U.S. ____ (2011). In reaffirming the "clear and convincing" standard of proof in *Microsoft*, the Supreme Court noted that the Federal Circuit has "never wavered" from its view that the burden is "constant and never

changes[.]” *Id.* at *3 (“That burden is constant and never changes and is to convince the court of invalidity by clear evidence.”).

Here, WNA suffered prejudice because Sabert’s counsel misstated the law regarding the presumption of validity of a patent, which, in the Court’s view, may have misled the jury.

In his opening statement, Mr. Sutton made *three* statements as to the patent’s ‘presumption of validity’:

Yes, the Government issues a patent and **there is a presumption that they didn’t make a mistake** and that **it’s valid unless -- unless there are things that the Patent Office did not know.**
(3/28/11 AM tr. at 55:15-18).

... **there is no presumption of validity.** There’s no presumption that the patent is correct from the Government if we show that there was prior art that the Patent Office did not consider
(3/28/11 AM tr. at 56:2-5).

And the presumption of validity, by the way, for the second patent, or the revised patent, does not apply. **The presumption does not apply** because there is new prior art such as Vergason and some other prior art that you’ll hear about that the Patent Office did not consider.

(3/28/11 AM tr. at 56:16-20) (emphasis added). Whereas in the first statement Mr. Sutton concedes that a presumption may exist, he then contradicts this statement by stating that no presumption exists under the circumstances of this case.

Although the Court took curative action by instructing the jury as the correct state of the law, the Court’s proper instruction was confusing in light of Mr. Sutton’s arguments. The Court’s instruction to the jury stated:

A granted patent is presumed to be valid, but that presumption of validity can **be overcome** if clear and convincing evidence is presented that proves the patent is invalid.

One example, a way in which a presumption may be overcome, is if the PTO has not considered, for whatever reason, **invalidating** prior art that is presented to you.

(Emphasis added). The instruction stated that the presumption could be “*overcome*, . . . if the PTO has not considered, for whatever reason, *invalidating* prior art that is presented to you.”

Without the two italicized words, the instruction seems to agree with Mr. Sutton’s statements that the presumption of validity did not apply where there was *any* prior art that the PTO did not consider.

The risk of confusion caused by Mr. Sutton’s improper statement of the law is clear: if no presumption existed because Sabert presented *any* piece of prior art not considered by the PTO (as Mr. Sutton’s statements suggest), the jury could more readily infer that the patent was invalid. In such a case, the jury need not have concluded that the presumption had been *overcome* by invalidating prior art. Thus, these statements were improper statements of law and confusing to the jury.

On retrial, Mr. Sutton shall not to dismiss the presumption of validity or fail to mention that it must be *overcome* by the prior art. The Court will endeavor to give an appropriate instruction if Mr. Sutton fails to make this distinction.

g. Sabert Confused Enablement and Written Description

As mentioned in this Court’s JNOV decision below, Sabert’s argument on written description confused written description and enablement.¹¹

¹¹ This was confusing to the jury. It need not be extensively discussed because the Court grants JNOV on the matter of written description. Mr. Sutton shall not bring up any aspect of written description in the new trial.

3. *The Jury's Inconsistent Verdict*

After having heard the prejudicial evidence of foreign decisions, unwarranted accusations of inequitable conduct, improper arguments that were inconsistent with claim construction and the plain meaning of metal, expressions of personal opinion, and the repeated testimony of counsel via leading questions, the jury returned an incomplete verdict not long after having received all of the evidence. Then, having been sent back to the jury room to complete the verdict form, the jury returned an inconsistent verdict.

The jury found that the independent claims were invalid based upon the lack of written description of the term “suitable for food contact without an overcoat.” However, the jury determined that the dependent claims, which incorporated the same term by reference, were not invalid based on written description. Both parties agree that the verdict was inconsistent and both posit that the jury mistakenly believed that dependent claims did not include the term. (Sabert Br. at 4; WNA Op. Br. at 6). On this basis, WNA argues it is entitled to a new trial on the issue of written description as well as obviousness because it demonstrates that the jury did not understand the relationship between independent and dependent claims. For its part, Sabert puts forth several arguments as to why such inconsistency should not affect the verdict. First, Sabert argues that the verdict reflected the jury’s intent to find any claim with the term “suitable for food contact without an overcoat” (including the dependent claims) invalid and that the Court should simply correct the verdict. Second, Sabert argues that the error was harmless in light of the jury’s obviousness verdict.

It would be improper for this Court to peer into the mind of the jury to try to divine the reason behind its inconsistent verdict for the benefit of either party. *United States v. Powell*, 469 U.S. 57, 66, 105 S.Ct. 471, 83 L.Ed.2d 461 (1984). Such speculation is inappropriate – the

inconsistency could have just as easily resulted from a scrivener's error, the jury's dislike of *either party*, or the jury's decision to determine the verdict by flipping coins. It is impossible to know. *See id.* at 478-79; *Freeman v. Chicago Park Dist.*, 189 F.3d 613, 615 (7th Cir. 1999). Thus, it is inappropriate to conclude that because the jury's verdict on written description was inconsistent, its verdict on obviousness was necessarily colored by its misunderstanding of claim dependence. Further, the inconsistency of the written description verdict does not necessarily infect that of obviousness – the two are independent bases for invalidity. Thus, the Court sees no reason that this inconsistency *requires* a new trial on obviousness.

Even so, there is no avoiding that an improper understanding of claim dependency (which both parties at points argue led to the inconsistent verdict) is one possibility for the inconsistent verdict. That misunderstanding would have affected the jury's obviousness deliberations because it suggests that they did not consider the dependent claims as a whole, but only as what they individually added. This would have been improper because the individual elements of almost every invention are obvious. *See The Ass'n For Molecular Pathology v. USPTO*, ___ F.3d ___, ___ (Fed. Cir. 2011) (“[O]nly God works from nothing. Men must work with old elements.”). Further, given Sabert's repeated misconduct, other improper considerations could well have influenced the verdict.

Thus, while the inconsistent verdict on written description is not an independent reason for a new trial on obviousness, it does legitimately color the Court's view of the potential prejudicial effect of Mr. Sutton's conduct and whether such conduct could reasonably have influenced the jury's verdict. Indeed, the Court concludes that the verdict may be the culmination of this misconduct.

4. *When Taken Together, Sabert's Acts of Misconduct Require a New Trial*

For the foregoing reasons, the Court determines that there is a “reasonabl[e] probabl[ity] that the verdict was influenced by prejudicial statements,” *Greenleaf v. Garlock, Inc.*, 174 F.3d at 366, and orders a new trial. This Court concludes that when taken together, Mr. Sutton’s acts of misconduct provide a sufficient basis to order a new trial. To hold otherwise would encourage the use of deliberately crafted misconduct and improper litigation tactics to influence a jury’s verdict.

IV. DISCUSSION – MOTION FOR JNOV

While the Court has determined that the misconduct of Sabert requires a new trial, that result does not imply that the Court should grant a motion for JNOV. The Court’s decision on the new trial motion was based upon improper evidence and argument before the jury, not the insufficiency of the evidence. The presence of improper conduct does not undermine a determination that sufficient evidence was present before the jury on the issues of obviousness and infringement.

However, based on the concessions of Sabert’s expert, Gary Vergason, the Court determines that no reasonable jury could have found against WNA on the matter of written description. This verdict could only have been influenced by improper considerations. Indeed, the verdict was inconsistent and, as discussed below, was subject to the argument of an improper theory of invalidity. As such, with respect to this element, the Court grants WNA’s motion for JNOV.

A. Standard of Review

A motion for judgment as a matter of law under Federal Rule of Civil Procedure 50(b) “should be granted only if, viewing the evidence in the light most favorable to the non-movant and giving it the advantage of every fair and reasonable inference, there is insufficient evidence

from which a jury reasonably could find liability.” *Lightning Lube, Inc. v. Witco Corp.*, 4 F.3d 1153, 1166 (3d Cir. 1993); *see also Mandile v. Clark Material Handling Co.*, 131 F. App'x 836, 838 (3d Cir. 2005). “In determining whether the evidence is sufficient to sustain liability, the court may not weigh the evidence, determine the credibility of witnesses, or substitute its version of the facts for the jury’s version.” *Lightning Lube*, 4 F.3d at 1166 (citing *Fineman v. Armstrong World Indus., Inc.*, 980 F.2d 171, 190 (3d Cir. 1992)). “A judge may overturn a jury verdict only when, as a matter of law, the record is critically deficient of that minimum quantity of evidence from which a jury might reasonably afford relief.” *Raiczyk v. Ocean County Veterinary Hosp.*, 377 F.3d 266, 268 (3d Cir. 2004)) (quotations omitted). However, “[t]he question is not whether there is literally no evidence supporting the party against whom the motion is directed but whether there is evidence upon which the jury could *properly* find a verdict for that party.” *Lightning Lube*, 4 F.3d at 1166 (quoting *Patzig v. O'Neil*, 577 F.2d 841, 846 (3d Cir. 1978)) (emphasis added).

B. Analysis

1. Written Description

Pursuant to paragraph one of 35 U.S.C. § 112, the specification of a patent must contain “a written description of the invention . . . in such full, clear, concise, and exact terms as to enable any person skilled in the art . . . to make and use the same.” 35 U.S.C. § 112, ¶ 1. The purpose behind the written description requirement is “to prevent an applicant from later asserting that he invented that which he did not.” *Amgen Inc. v. Hoechst Marion Roussel, Inc.*, 314 F.3d 1313, 1330 (Fed. Cir. 2003) (citing *Vas-Cath Inc. v. Mahurkar*, 935 F.2d 1555, 1561 (Fed. Cir. 1991)).

To meet the written description requirement, the specification must “describe the invention sufficiently to convey to a person of skill in the art that the patentee had possession of the claimed invention at the time of the application, i.e., that the patentee invented what is claimed.” *Id.*

However, “[a] claim will not be invalidated on section 112 grounds simply because the embodiments of the specification do not contain examples explicitly covering the full scope of the claim language.” *Lizard Tech*, 424 F.3d at 1344-45. “That is because the patent specification is written for a person of skill in the art, and such a person comes to the patent with the knowledge of what has come before.” *Id.*; see *Ariad Pharms., Inc. v. Eli Lilly & Co.*, 598 F.3d 1336, 1351 (Fed. Cir. 2010) (en banc). Thus, “it is unnecessary to spell out every detail of the invention in the specification; only enough must be included to convince a person of skill in the art that the inventor possessed the invention[.]” *LizardTech*, 424 F.3d at 1345.¹²

The Court denied summary judgment on the matter of the written description of “suitability with food contact without an overcoat.” However, given the concessions made by Sabert’s expert, Gary Vergason, no reasonable juror could have found that the “suitable for food contact without an overcoat” provision lacked written description.

Sabert contended that the “suitable for food contact without an overcoat” term was unsupported in the specification. Essentially Sabert’s contention was this: The term was added only in reexamination in order to distinguish the Spir-It cutlery, which WNA distinguished by adding this term and asserting that the aluminum in the Spir-It cutlery would not be suitable for food contact because it was toxic. Sabert contends that because the patent, as filed, would not

¹²“Compliance with the written description requirement is a question of fact,” *Enzo Biochem, Inc. v. Gen-Probe Inc.*, 323 F.3d 956, 968 (Fed. Cir. 2002); *Laryngeal Mas Co. v. Ambu*, 619 F.3d 1367, 1373 (Fed. Cir. 2010), and a party alleging a violation of the written description requirement must prove its allegations by clear and convincing evidence. *SIBIA Neurosciences, Inc. v. Cadus Pharm. Corp.*, 225 F.3d 1349, 1355 (Fed. Cir. 2000).

have informed the person of ordinary skill of which metals meet this criterion and because the inventors did not indicate that aluminum was toxic, “suitable for food contact without an overcoat” was unsupported in the specification.

The heart of this question is whether a person of ordinary skill in the art would have been convinced that, for the embodiment without the overcoat, the specification contemplated that the metallic coating had to be “suitable for food contact without an overcoat.” After being walked through the various places in the patent where the description provides concern about toxicity, Mr. Vergason admitted this point:

Q: Thank you. And, again, you understand the reason we’re discussing whether, even though the precise word suitable for overcoat, I’m sorry, suitable for food contact without an overcoat do not appear exactly as such in the 542 patent is because of Sabert’s defense that the claim should be held invalid for lack of written description support, correct?

A: No.

Q: You don’t understand that that’s why we’re talking about suitability for food contact without an overcoat?

A: I understand that that’s what we’re talking about, but I also understand that you cannot find that language in the body of the spec of the patent because that language was added after the first re-exam. You cannot go back in and change the spec. You can only make changes or reductions to your claims.

Q: Unless, of course, it’s clear from the specification that that’s what the inventors intended, correct?

A: It’s not totally clear but your statement is correct, if that’s what the inventors intended.

Q: But you have agreed with me, have you not, that one skilled in the art reading through this would understand that the purpose of the invention is a food service item that whether it has an overcoat or not has to be suitable for food contact in either case, correct?

A: It should be, yes.

(4/1/11 AM tr. at 80). The other passages quoted by Sabert only show that Mr. Vergason believed that such information was not explicitly in the specification. (4/1/11 AM tr. 51, 91; 3/31/11 PM tr. at 3-4, 20-21). However, the standard does not require the information to be explicitly in the specification. *LizardTech*, 424 F.3d at 1345 (the written description need not

explicitly map out every detail of the invention so long as a person of ordinary skill in the art after reading the description would understand it to be present).

Further, whether the inventors did not know that *aluminum* was toxic at the time of the invention is irrelevant. The words “but not aluminum” are not in the claim and are not at issue here; the words “suitability for food contact without an overcoat” are. This demonstrates a confusion of the written description requirement with the enablement requirement. As acknowledged by the Federal Circuit, these are similar, but distinct inquiries. *Ariad Pharm., Inc. v. Eli Lilly and Co.*, 598 F.3d 1336, 1340 (Fed. Cir. 2010) (en banc); *Vas-Cath Inc. v. Mahurkar*, 935 F.2d 1555, 1563 (Fed. Cir. 1991).

The easiest way to distinguish them is to examine the purposes of each doctrine. The purpose behind the written description requirement is “to prevent an applicant from later asserting that he invented that which he did not.” *Amgen Inc. v. Hoechst Marion Roussel, Inc.*, 314 F.3d 1313, 1330 (Fed. Cir. 2003) (citing *Vas-Cath Inc.*, 935 F.2d at 1561). The purpose of the enablement requirement is different – it is to ensure that the inventor has fulfilled its side of the bargain in order to obtain the patent monopoly. *Invitrogen Corp. v. Clontech Labs.*, 429 F.3d 1052, 1063 (Fed. Cir. 2005). The inventor has done so only if he has described the invention in a way that a person can *use* that invention. *Id.*; *see also In re Wands*, 858 F.2d 731 (Fed. Cir. 2008); *Ariad Pharm.*, 598 F.3d 1346 (the purpose of the enablement requirement is to “require the patentee to describe his invention so that others may construct and use it after the expiration of the patent”); *Lizardtech*, 424 F.3d at 1344 (this element is the “quid pro quo” of the patent bargain).

Thus, the written description requirement looks backward from the claim language. A person must look back from an element in the claim language to confirm that the inventor

contemplated that element as part of the invention in the original specification. *See Lizardtech*, 424 F.3d at 1345 (the specification must “reasonably convey to a person skilled in the art that [the inventor] had possession of the claimed subject matter at the time of filing”). The enablement requirement is forward looking. A person must look forward from the specification and the claim language to whether a person of skill would have to unduly experiment in order to *practice* the invention. *See Minerals Separation v. Hyde*, 242 U.S. 261, 270 (1916).

As such, Sabert’s argument that that aluminum was nontoxic is *irrelevant* to the written description of “suitability for food contact without an overcoat” because aluminum’s toxicity is not put into issue by the claim language. Only whether a metal *had* to be “suitable” is relevant. Mr. Vergason conceded this point. (4/1/11 AM tr. at 80). Whether the inventor knew, or disclosed in the original application that aluminum was toxic is a question of *enablement* because it asks whether inventor gave the person of skill sufficient information to *select* a nontoxic metal without undue experimentation. *See also National Recovery Techs. Inc. v. Magnetic Separation Sys., Inc.*, 166 F.3d 1190, 1196 (Fed. Cir. 1999) (inoperative embodiments are relevant to the enablement inquiry). This is a question of experimentation and success in making the invention, and thus enablement. However, Sabert never asserted an enablement defense at trial and could not avail itself of this argument. While such inquiries often “rise and fall together,” *LizardTech*, 424 F.3d at 1345, this is a case where they do not. *See Vas-Cath Inc.*, 935 F.2d at 1562.¹³

Sabert repeatedly put forth evidence that the inventors did not know of aluminum’s toxicity at the time of filing undermined the written description of the term “suitable for food

¹³ The example cited in *Vas-Cath* was a disclosure “where the specification discusses only compound A and contains no broadening language of any kind [might] very well enable one skilled in the art to make and use compounds B and C; yet the class consisting of A, B and C has not been described.” *Vas-Cath*, 935 F.2d at 1562.

contact without an overcoat.”¹⁴ In Sabert’s view, because such was the reason for the change, it must undermine its written description. However, the support for the claim term – here “suitability for food contact without an overcoat” -- not the reason behind its change is what is at issue in the written description requirement.

Thus, Mr. Vergason having conceded the only relevant point, the Court finds that no reasonable jury could have found that the claims were invalid based on lack of written description.

2. Infringement of Claim 25 and Obviousness

The Court next turns to whether Sabert put sufficient evidence before the jury to allow a reasonable jury to conclude that its titanium cutlery did not infringe claim 25, and whether a reasonable jury could have found that the invention was obvious based on clear and convincing evidence. The Court, having carefully reviewed the record and considered the arguments of WNA, determines that a reasonable jury could have found for either party. Thus, the Court sees no reason to award judgment to WNA.

IV. Conclusion

Having considered the parties’ submissions, the Court grants the motion for a new trial with respect to obviousness pursuant to Federal Rule of Civil Procedure 59(a). In the new trial, Mr. Sutton and his witnesses shall not repeat the litany of improper conduct mapped in this opinion. If they do so, the Court will impose sanctions upon them. The Court also grants

¹⁴ Indeed, Sabert does not dispute that it repeatedly made this argument. While this incorrect argument was undoubtedly confusing to the jury, the Court does not conclude that it was intentional. Indeed, members of the Federal Circuit often accuse one another of confusing or conflating the two doctrines. *Lizardtech, Inc. v. Earth Resource Mapping, Inc.*, 433 F.3d 1373, 1380-82 (Fed. Cir. 2006) (Rader, J., dissenting from the denial of rehearing *en banc*) (accusing the majority of giving mere lip service to the distinction between written description and enablement). However, there is no doubt that the doctrines are distinct. *Ariad Pharm., Inc. v. Eli Lilly and Co.*, 598 F.3d 1336, 1340 (Fed. Cir. 2010) (en banc) (finding the doctrines are distinct from one another).

WNA's motion for JNOV on the matter of written description, but denies that motion with respect to written description and enablement.

Date: August 5, 2011

/s/ Garrett E. Brown, Jr.
GARRETT E. BROWN, JR., U.S.D.J.