

called a ferrule, a screw within the ferrule, and a knob secured to the head of the screw. The ferrule is configured to attach to the first part and is configured so that the screw does not fall out of the captive screw assembly while the captive screw is used to join the two parts.” Id. at 682; see also Southco, Inc. v. Fivetech Tech. Inc., 2012 WL 246253, at *1 (E.D. Pa. Jan. 25, 2012), aff’d, 611 F. App’x 681 (Fed. Cir. 2015) (“A captive screw, or captive fastener, is a device which holds a screw in place while the screw is used to connect two panels. A cylindrical ferrule holds the screw [i.e., ‘threaded shaft’] and a knob can be placed over the screw head.”).

Southco brought this lawsuit alleging that Fivetech infringed multiple patents and trademarks that Southco had registered with the U.S. Patent and Trademark Office (“PTO”). Fivetech filed several counterclaims in response. After a period of discovery, Fivetech sought summary judgment of noninfringement with respect to the three patents and two trademarks it was accused of infringing.

The Honorable Mary A. McLaughlin (ret.) granted Fivetech’s motions for summary judgment of noninfringement with respect to U.S. Patent Nos. 5,851,095 (‘095 Patent); 6,280,131 (‘131 Patent); and, the patent currently at issue before me, 6,468,012 (‘012 Patent). Judge McLaughlin further granted Fivetech’s motion for summary judgment on U.S. Trademark Nos. 2,478,685 and 3,678,153. See Southco, Inc. v. Fivetech Tech. Inc., 2012 WL 246253 (E.D. Pa. Jan. 25, 2012) (granting Fivetech’s motion for partial summary judgment of the ‘095 and ‘131 Patents); Southco, Inc. v. Fivetech Tech. Inc., 2012 WL 987495 (E.D. Pa. Mar. 23, 2012) (granting Fivetech’s motion for partial summary judgment on claims 16 and 17 of the ‘095 Patent); Southco, Inc. v. Fivetech Tech. Inc., 2013 WL 5298576 (E.D. Pa. Sept. 20, 2013) (granting Fivetech’s motion for summary judgment of noninfringement of all claims of the ‘012 Patent); Southco, Inc. v. Fivetech Tech. Inc., 982 F. Supp. 2d 507, 509 (E.D. Pa. 2013) (granting

Fivetech's motion for partial summary judgment of noninfringement of U.S. Trademarks 2,478,685 and 3,678,153). The '012 and '131 Patents are continuations of the '095 Patent.

Because Fivetech prevailed on the issue of noninfringement with respect to all of the patents and trademarks involved in the case, it voluntarily withdrew its counterclaims for certain state law torts (without prejudice). Judge McLaughlin then certified her rulings as final judgments pursuant to Federal Rule of Civil Procedure 54(b), and Southco appealed those judgments to the United States Court of Appeals for the Federal Circuit.

On April 10, 2015, the Federal Circuit affirmed-in-part, reversed-in-part, vacated-in-part, and remanded the case for further proceedings. Southco, Inc. v. Fivetech Tech. Inc., 611 F. App'x 681 (Fed. Cir. 2015). The Federal Circuit affirmed Judge McLaughlin's grant of summary judgment of noninfringement with respect to U.S. Patent Nos. 5,851,095 and 6,280,131, as well as both of the asserted trademarks.

However, with respect to the '012 Patent, the Federal Circuit concluded that the district court "improperly granted summary judgment of noninfringement ... because Southco presented evidence raising a genuine question of material fact as to noninfringement, [and] improperly construed the terms 'rigidly secure' and 'material from said knob flows into said chamfer[.]'" Id. at 693. Thus, the Federal Circuit vacated the grant of summary judgment as to claims 1–6 and 8–12 of the '012 Patent because the terms "rigidly secure" and "material from said knob flows into said chamfer" were improperly construed. The Federal Circuit also reversed the grant of summary judgment as to claims 7, 13, and 14 of the '012 Patent, concluding that Southco presented evidence raising a genuine dispute of material fact. Id.

This matter was reassigned to my docket while Fivetech's Petition for Writ of Certiorari before the United States Supreme Court was pending. On December 7, 2015, the Supreme Court denied Fivetech's Petition. See Fivetech Tech. Inc. v. Southco, Inc., 136 S. Ct. 587 (2015).

Thereafter, I held a status conference and ordered the parties to file “any relevant motions” in accordance with the Federal Circuit’s decision as it related to the ‘012 Patent. (Doc. No. 293.) Fivetech filed its current motion for summary judgment arguing invalidity. Southco filed its current motion for partial summary judgment of infringement with respect to Claim 7 of the ‘012 Patent. Fivetech then filed a cross motion for summary judgment of noninfringement, but did so approximately one month beyond the deadline established by my scheduling order. In response, Southco filed a motion to strike Fivetech’s untimely cross motion. All four motions have been fully briefed, and are ripe for consideration.

II. LEGAL STANDARD

A party moving for summary judgment bears the initial burden of demonstrating that there are no genuine issues of material fact in dispute, and that judgment is appropriate as a matter of law. Fed. R. Civ. P. 56(a); Celotex Corp. v. Catrett, 477 U.S. 317, 323 (1986). Once a properly supported motion for summary judgment has been made, the burden shifts to the non-moving party, who must set forth specific facts showing that there is a genuine issue of material fact for trial. Anderson v. Liberty Lobby, Inc., 477 U.S. 242, 250 (1986).

An issue is “genuine” if a reasonable jury could rule in favor of the non-moving party based on the evidence presented. Kaucher v. Cnty. of Bucks, 455 F.3d 418, 423 (3d Cir. 2006). A factual dispute is “material” if it might affect the outcome of the suit under the appropriate governing law. Id. at 423. The non-moving party cannot avert summary judgment with speculation or conclusory allegations, but rather must cite to the record. Ridgewood Bd. of Educ. v. N.E. for M.E., 172 F.3d 238, 252 (3d Cir. 1999); Fed. R. Civ. P. 56(c). On a motion for summary judgment, the court considers the evidence in the light most favorable to the non-moving party. Anderson, 477 U.S. at 256.

III. ANALYSIS

A. Fivetech's Motion for Summary Judgment – Invalidity of the '012 Patent²

In assessing summary judgment, the evidence is viewed through the prism of the evidentiary standard of proof that would apply at a trial on the merits. TriMed, Inc. v. Stryker Corp., 608 F.3d 1333, 1339–40 (Fed. Cir. 2010) (quotations and citations omitted). “Because patents are presumed valid, a moving party seeking to invalidate a patent at summary judgment must submit such clear and convincing evidence of facts underlying invalidity that no reasonable jury could find otherwise.” Id. (quotations and citations omitted).

Fivetech insists that the Federal Circuit's claim constructions on appeal presented new invalidity issues on remand, and as result, these issues are ripe for consideration. Specifically, Fivetech argues that the '012 Patent is invalid as a matter of law for violation of the “written description” and “enablement” requirements set forth in 35 U.S.C. § 112, first paragraph. (Def.'s Mot. Summ. J. 6–7, 17–26.) While Fivetech recognizes that the '012 Patent is presumed valid, and that it must point to clear and convincing evidence to support a finding of invalidity, Fivetech stresses that the “evidence is overwhelming that the claims ... far exceed the scope [of] what was described as the invention and what was enabled [such that no] reasonable juror could find otherwise.” (Id. at 17.)

In Cardiac Pacemakers, Inc. v. St. Jude Med., Inc., 576 F.3d 1348 (Fed. Cir. 2009), the Federal Circuit recognized that its broader claim constructions on appeal could potentially result in the defendant raising “directly related new issues” on remand, such as whether the “now-asserted scope of the claims is supported by the specification” (i.e., the written description and enablement requirements); see also Liebel-Flarsheim Co. v. Medrad, Inc., 481 F.3d 1371, 1380

² For this motion, all facts and reasonable inferences that can be drawn therefrom will be viewed in the light most favorable to Southco, the non-moving party.

(Fed. Cir. 2007) (recognizing that the court’s broader claim construction on appeal could result in a subsequent finding of invalidity based on lack of enablement). Here, Fivotech included invalidity based upon 35 U.S.C. § 112 as an affirmative defense in its Answer. (Def.’s Answer ¶ 47.) Therefore, I will address Fivotech’s arguments. However, I note that Fivotech never sought leave to conduct additional discovery on these issues following remand.

Section 35 U.S.C. § 112, first paragraph, states:

The specification shall contain a written description of the invention, and of the manner and process of making and using it, in such full, clear, concise, and exact terms as to enable any person skilled in the art to which it pertains, or with which it is most nearly connected, to make and use the same, and shall set forth the best mode contemplated by the inventor of carrying out his invention.³

The United States Court of Appeals for the Federal Circuit has interpreted this language as setting forth both a written description requirement and an enablement requirement which are independent of one another. See Ariad Pharm., Inc. v. Eli Lilly & Co., 598 F.3d 1336, 1340 (Fed. Cir. 2010). While these requirements “often rise or fall together,” they must be evaluated separately. Id. at 1352 (“[R]equiring a written description of the invention plays a vital role in curtailing claims that do not require undue experimentation to make and use, and thus satisfy enablement, but that have not been invented, and thus cannot be described.”).

1. Written Description

“The essence of the written description requirement is that a patent applicant, as part of the bargain with the public, must describe his or her invention so that the public will know what

³ In 2011, Congress amended several parts of the Patent Act by way of the Leahy–Smith America Invents Act, Pub.L. 112–29, 125 Stat. 284. Those amendments modified § 112 in minor respects not pertinent here. In any event, the amended versions of those provisions are inapplicable to patent applications filed before September 16, 2012, and proceedings commenced before September 16, 2011. Here, the patent application was filed before September 16, 2012, and this litigation commenced before September 16, 2011. Therefore, my citations to the Patent Act refer to the 2006 edition of the United States Code. See Nautilus, Inc. v. Biosig Instruments, Inc., 134 S. Ct. 2120, 2131 (2014).

it is and that he or she has truly made the claimed invention.” AbbVie Deutschland GmbH & Co., KG v. Janssen Biotech, Inc., 759 F.3d 1285, 1298 (Fed. Cir. 2014). Put another way, “[t]he purpose of the written description requirement is to prevent an applicant from later asserting that he invented that which he did not.” Amgen Inc. v. Hoechst Marion Roussel, Inc., 314 F.3d 1313, 1330 (Fed. Cir. 2003).

“To satisfy the written description requirement, the applicant must convey with reasonable clarity to those skilled in the art that, as of the filing date sought, he or she was in possession of the invention, and demonstrate that by disclosure in the specification of the patent.” Centocor Ortho Biotech, Inc. v. Abbott Labs., 636 F.3d 1341, 1348 (Fed. Cir. 2011) (internal quotations and citations omitted). “Assessing such ‘possession as shown in the disclosure’ requires ‘an objective inquiry into the four corners of the specification.’” Id. at 1348. “Ultimately, the specification must describe an invention understandable to [a person of ordinary skill in the art] and show that the inventor actually invented the invention claimed.” Id. at 1348 (quotations omitted); see also Ariad Pharm., Inc. v. Eli Lilly & Co., 598 F.3d 1336, 1351 (Fed. Cir. 2010).

“Whether a specification satisfies the written description requirement is a question of fact.” Johns Hopkins Univ. v. 454 Life Scis. Corp., 183 F. Supp. 3d 563, 568 (D. Del. 2016) (citing GlaxoSmithKline LLC v. Banner Pharmacaps, Inc., 744 F.3d 725, 729 (Fed. Cir. 2014)). The Federal Circuit has thus recognized that “determining whether a patent complies with the written description requirement will necessarily vary depending on the context.” Ariad Pharm., Inc., 598 F.3d at 1351. As such, “the level of detail required to satisfy the written description requirement varies depending on the nature and scope of the claims and on the complexity and predictability of the relevant technology.” Id. at 1351. However, the issue can be “amenable to summary judgment in cases where no reasonable fact finder could return a verdict for the non-

moving party.” PowerOasis, Inc. v. T-Mobile USA, Inc., 522 F.3d 1299, 1307 (Fed. Cir. 2008). To meet this burden, a “defendant must provide clear and convincing evidence that persons skilled in the art would not recognize in the disclosure a description of the claimed invention.” Amgen Inc. v. Sanofi, 2017 WL 27253, at *6 (D. Del. Jan. 3, 2017).

Fivetech argues that the invention described in the ‘012 Patent is “essentially an improved press-fit that employs a chamfer on the lower edge of the screw to receive displaced knob material during a bottom-up press-fit.” (Fivetech Mot. Summ. J. 23.) Thus, Fivetech insists that the disclosed invention is really a *process* for manufacturing captive screws (i.e., a bottom-up press-fit method of attaching a screw head into a knob). See id at 4 (“Southco described in its patent a new way of press-fitting a screw head into a knob from the bottom of the knob, as opposed to the prior art press-fits wherein the screw head was inserted from the top into the knob.”) Fivetech stresses that it uses an injection-molding process to manufacture its captive screws (the accused product), and emphasizes that there is “no description in the specification of the use of a chamfer in a screw where the knob is injection-molded onto the screw head[.]” (Fivetech Mot. Summ. J. 23–24.)

Southco responds that the “captive screw” of the ‘012 Patent is the claimed invention, and the specific claims of the Patent recite structural features, i.e., the structural relationship and configuration between the threaded screw, knob, and ferrule which make up the claimed captive screw. (Southco Resp. 3.) While Southco recognizes that a “press-fit” process *may* be used to manufacture the claimed screws, and while Southco maintains that the specification teaches to that effect, Southco insists that none of the asserted claims requires that such a process (or any other process) be used. As such, Southco contends that Fivetech’s reliance on the absence of Fivetech’s injection-molding manufacturing process from the ‘012 Patent specification is entirely irrelevant for purposes of the written description requirement. (Id. at 17–19.)

As a threshold issue, I first note that Fivotech submitted a procedurally deficient motion for summary judgment. This Court's Policies and Procedures plainly state that "[a]ny motion for summary judgment filed pursuant to Fed. R. Civ. P. 56 shall include a short and concise Statement of Undisputed Facts as a separate exhibit." (P&P at 7 ¶ 10.) Fivotech failed to submit a statement of undisputed facts. Fivotech's motion could be denied on this basis alone.

That aside, much of Fivotech's motion and accompanying brief are comprised of attorney argument. While a patent can be found invalid for violating the written description requirement based "solely on the face of the patent specification," Fivotech—as the moving party—bears the burden of citing to relevant portions of the record to initially demonstrate the absence of materially disputed facts. Centocor Ortho Biotech, Inc., 636 F.3d at 1347. Fivotech includes a few sporadic, selective, and isolated citations to the specification, but its arguments avoid any in-depth discussion as to how one skilled in the art would be unable to ascertain or understand the claimed invention based on the specification (i.e., Fivotech fails to address how the disclosure could not be relied upon to reasonably convey to one skilled in the art that the inventor behind the '012 Patent had possession of the claimed subject matter as of the filing date). See Synthes USA, LLC v. Spinal Kinetics, Inc., 734 F.3d 1332, 1341 (Fed. Cir. 2013); Amgen Inc. v. Sanofi, 2017 WL 27253, at *6 (D. Del. Jan. 3, 2017) ("[A] defendant must provide clear and convincing evidence that persons skilled in the art would not recognize in the disclosure a description of the claimed invention."). And in fact, Fivotech does not cite to any expert evidence outlining what the specification would reasonably convey to one skilled in the art.

Fivotech also stresses that its injection-molding process does not appear in the specification. However, the Federal Circuit has instructed that a "patentee need only describe the product as claimed, and need not describe an unclaimed method of making the claimed product."

Crown Packaging Tech., Inc. v. Ball Metal Beverage Container Corp., 635 F.3d 1373, 1383 (Fed. Cir. 2011) (citations omitted).⁴

Viewing the evidence of record and the reasonable inferences drawn therefrom in the light most favorable to Southco, I conclude that Fivetech has not set forth undisputed clear and convincing evidence of facts underlying invalidity such that no reasonable jury could find the written description requirement to be satisfied. As such, whether the claims of the ‘012 Patent are overly broad requires consideration by a fact finder.

2. Enablement

Section § 112, first paragraph, contains a separate enablement requirement for patentability. “Enablement is a legal determination of whether a patent enables one skilled in the art to make and use the claimed invention.” Streck, Inc. v. Research & Diagnostic Sys., Inc., 665 F.3d 1269, 1288 (Fed. Cir. 2012). “Enablement serves the dual function . . . of ensuring adequate disclosure of the claimed invention and of preventing claims broader than the disclosed invention. This important doctrine prevents both inadequate disclosure of an invention and overbroad claiming that might otherwise attempt to cover more than was actually invented.” MagSil Corp. v. Hitachi Glob. Storage Techs., Inc., 687 F.3d 1377, 1380–81 (Fed. Cir. 2012).

“The enablement requirement is met where one skilled in the art, having read the specification, could practice the invention without ‘undue experimentation.’” Streck, Inc., 665 F.3d at 1288 (quoting In re Wands, 858 F.2d 731, 736–37 (Fed. Cir. 1988)). “Whether undue experimentation is required is not a single, simple factual determination, but rather is a conclusion reached by weighing many factual considerations.” Id. at 1288 (quotations omitted).

⁴ Fivetech also cites to the prosecution history of the ‘095 Patent, of which the ‘012 Patent is a continuation, and argues that Southco, in distinguishing prior art, previously acknowledged that the purpose of the chamfer is to facilitate a bottom-up press-fit. (Fivetech Mot. Summ. J 15; Ex. 8-2 at 6 ¶ c.) However, the excerpt to which Fivetech cites in support of this proposition does not contain the phrase “press-fit.”

Thus, although enablement is a question of law, it is based on underlying factual findings. MagSil Corp., 687 F.3d at 1380. The Federal Circuit has instructed that “[t]he specification need not explicitly teach those in the art to make and use the invention; the requirement is satisfied if, given what they already know, the specification teaches those in the art enough that they can make and use the invention without ‘undue experimentation.’” Amgen Inc. v. Hoechst Marion Roussel, Inc., 314 F.3d 1313, 1334 (Fed. Cir. 2003).

In Wands, the Federal Circuit set forth the following factors to consider when determining whether a disclosure requires “undue experimentation”: (1) the quantity of experimentation necessary; (2) the amount of direction or guidance presented; (3) the presence or absence of working examples; (4) the nature of the invention; (5) the state of the prior art; (6) the relative skill of those in the art; (7) the predictability or unpredictability of the art; and (8) the breadth of the claims. These factors are illustrative, not mandatory, and it is not necessary that all of them are reviewed to find a disclosure enabling. Streck, Inc., 665 F.3d at 1288.

Additionally, “[a]lthough a specification need not disclose what is well known in the art, [t]ossing out the mere germ of an idea does not constitute enabling disclosure. A patent cannot simply rely on the knowledge of a person of ordinary skill to serve as a substitute for the missing information in the specification.” Johns Hopkins Univ. v. 454 Life Scis. Corp., 183 F. Supp. 3d 563, 568–69 (D. Del. 2016) (citing ALZA Corp. v. Andrx Pharm., LLC, 603 F.3d 935, 941 (Fed. Cir. 2010)) (internal quotations omitted); see also Netgear, Inc. v. Ruckus Wireless, Inc., 5 F. Supp. 3d 592, 604–05 (D. Del. 2013). “The scope of [patent] claims must be less than or equal to the scope of the enablement. The scope of enablement, in turn, is that which is disclosed in the specification plus the scope of what would be known to one of ordinary skill in the art without undue experimentation.” Invitrogen Corp. v. Clontech Labs., Inc., 429 F.3d 1052, 1070–71 (Fed. Cir. 2005).

A party must prove invalidity premised upon nonenablement by clear and convincing evidence, and this determination must be made as of the filing date of the patent application. MagSil Corp., 687 F.3d at 1380; Amgen Inc., 2017 WL 27253, at *5.

In support of its lack of enablement argument, Fivetech states that the '012 Patent “teaches how to accomplish a bottom-up press-fit of a screw head into a knob, employing a chamfer specifically positioned on the lower periphery of the screw head in order to facilitate the bottom-up press-fit.” (Fivetech. Mot. Summ. J. 7.) Fivetech asserts that “[n]owhere does the invention described in the '012 Patent teach one of ordinary skill in the art how to injection mold a knob onto a screw head, or what role, if any, a chamfer located on the lower periphery of the screw head would play in an injection molding process.” (Id.) Once again, Fivetech appears to argue that the manufacturing process that it uses to produce the accused product is not enabled by the specification.

The Federal Circuit has recognized that “[t]he enablement requirement is met if the description enables *any* mode of making and using the invention.” Invitrogen Corp. v. Clontech Labs., Inc., 429 F.3d 1052, 1071 (Fed. Cir. 2005) (citations omitted) (emphasis added). On this point, it is important to note that Fivetech acknowledges that the “'012 Patent teaches how to accomplish a bottom-up press-fit of a screw head onto a knob[.]” (Fivetech Mot. Summ. J. 7.)

Moreover, although Fivetech generally cites to the Wands factors in its statement of the law, it identifies no specific evidence that would potentially be probative of whether or not the invention claimed and/or disclosed in the '012 Patent requires “undue experimentation,” and thus is not enabled. Nor does Fivetech discuss how any of the Wands factors apply to the technology at issue in this case. See Netgear, Inc. v. Ruckus Wireless, Inc., 5 F. Supp. 3d 592, 617 (D. Del. 2013) (“While defendant may succeed in showing that this limitation is not enabled, viewing all facts in favor of [the] plaintiff, defendant has not met the clear and convincing standard for

invalidity.... [The] defendant has not provided evidence of what type of experimentation, if any, would be needed to identify [whether such experimentation was ‘undue’].”).

While I recognize that the issue of enablement is a legal determination, challenges to validity based on enablement require “weighing many factual considerations.” Here, when viewed in the light most favorable to Southco, I conclude that Fivetech has not set forth sufficient undisputed clear and convincing evidence that would permit resolution of this issue at this stage. Accordingly, Fivetech’s motion will be denied in this regard.

B. Southco’s Motion for Partial Summary Judgment – Infringement of Claim 7

Because Southco is now the moving party, I will view the evidence and reasonable inferences in Fivetech’s favor.

The Federal Circuit reversed Judge McLaughlin’s grant of summary judgment of noninfringement as to Claim 7 of the ‘012 Patent.⁵ The Federal Circuit concluded that an engineering drawing of the accused product, which was produced by Fivetech, and Southco’s expert’s testimony regarding the presence of the “annular chamfer” limitation were sufficient to demonstrate a question of material fact. Southco, Inc. v. Fivetech Tech. Inc., 611 F. App’x 681, 689 (Fed. Cir. 2015) (“A drawing—produced by [Fivetech]—plausibly showing that a product includes a claim limitation and testimony confirming the same is sufficient evidence to present a question of material fact.”). Following remand, Southco now moves for a judicial determination that Fivetech’s captive screws infringe Claim 7 of the ‘012 Patent as a matter of law.

⁵ Independent Claim 7 does not contain the “rigidly secure” or “material from said knob fills said chamfer” limitations that were the focus of Fivetech’s written description and enablement challenges. Therefore, I will address Southco’s infringement argument as to Claim 7. Additionally, I note that in January 2014, the Patent Trial and Appeal Board found independent claims 1 and 6 of the ‘012 Patent invalid as anticipated by prior art. Fivetech Tech., Inc. Requester, Respondent, 2014 WL 174467, at *11 (Jan. 13, 2014). However, that decision did not hold independent claim 7 invalid, and thus it does not impact my current analysis.

On the issue of infringement, “[s]ummary judgment is appropriate when it is apparent that only one conclusion as to infringement could be reached by a reasonable jury.” Telemac Cellular Corp. v. Topp Telecom, Inc., 247 F.3d 1316, 1323 (Fed. Cir. 2001). Evaluating a claim of infringement involves a two-part inquiry. Bayer v. Elan Pharmaceutical Research Corp., 212 F.3d 1241, 1247 (Fed. Cir. 2000). First, the claims are construed so as to define the scope of the asserted claims. Second, “the claims, as construed, are compared to the accused device.” Id.

Regarding the second step, an accused device can infringe the asserted claims of a patent either literally or under “the doctrine of equivalents.” Id. Literal infringement requires the patentee to prove that “the accused device contains each limitation of the asserted claim(s).” Id. If the accused device does not meet every limitation, “infringement may still occur under the doctrine of equivalents if there is not a substantial difference between the limitations of the claim and the accused [device].” Id. at 1250.

Independent Claim 7 of the ‘012 Patent states:

A captive screw attachable to a panel, for attaching the panel to a surface, the surface having a threaded hole, the captive screw comprising:

- a) a screw having a head portion and a shaft having at least a threaded portion, said head portion having a top surface and a bottom surface, said head portion further having an **annular chamfer** peripheral to said bottom surface of said head portion;
- b) a knob secured to said head portion; and
- c) a ferrule having a first end and a second end through which said shaft extends, said ferrule having a panel attachment means at said first end to secure the captive screw to the panel.

'012 Patent, col. 7 ll. 3–16 (emphasis added). Southco argues that each limitation in Claim 7 of the '012 Patent is *literally* present in the accused product.⁶

Fivetech devotes its entire response to disputing that the accused product contains a “chamfer” on the bottom of the screw head. The parties agree that a “chamfer” is an angled or beveled edge. (Southco Mot. Summ. J. 7–8; Fivetech Resp. 2.) Thus, I will focus my analysis on whether Southco has demonstrated that a reasonable jury could only reach one conclusion as to the presence of the “annular chamfer” limitation in the accused product.

Southco asserts that the following figures, which are included in the '012 Patent, illustrate an embodiment of a captive screw with the specific features of Claim 7. The portions highlighted in yellow correspond to the annular chamfer limitation (29) presently at issue:

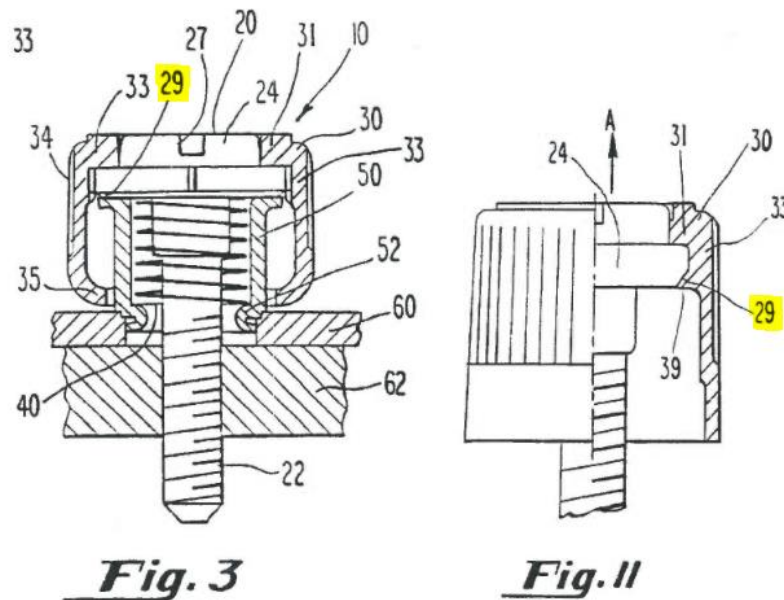

In arguing that the accused product contains a chamfer, Southco again relies heavily on an engineering drawing of the accused product produced by Fivetech during discovery:

⁶ Southco has only argued in its motion that the accused product literally infringes the '012 Patent. (Southco Mot. Summ. J. 6.) Thus, I will not address whether the accused product infringes under the doctrine of equivalents.

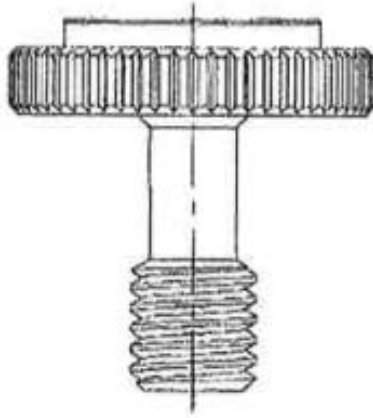

Southco maintains that this drawing indisputably establishes the existence of a chamfer on the bottom of the accused product's screw head. (Southco Mot. Summ. J. 9.)

Although Fivetech does not dispute that the engineering drawing is representative of the accused product, Fivetech does dispute that the drawing irrefutably depicts a chamfered edge. (Fivetech Resp. 16.) Additionally, Fivetech's President, Gary Ting-Jui Wang, submitted a declaration wherein he attests that the "standard screws" used in the accused product contain a "natural round" edge on the bottom of the screw head as a result of the "cold forming process" used to manufacture them. (Decl. of Gary Ting-Jui Wang, ¶¶ 1-9, Doc. No. 207-2.) He further states that he believes the screws used by Southco require a "specially-designed mold or an extra step of cutting or shaving the edge of the screw head to form the chamfer area[.]" (Id. at ¶ 9.)

Viewing this evidence in the light most favorable to Fivetech, I cannot conclude, as a matter of law, that a reasonable jury would only reach one conclusion as to whether or not the drawing depicted above exhibits an angled or beveled edge on the bottom of the screw head such that the annular chamfer limitation is literally present in the accused product.

In further support of its motion, Southco relies on the expert report of Dr. John D. Pratt, who examined the accused product and concluded that it contains the limitation of an annual chamfer peripheral to the bottom surface of the screw head. (Southco Mot. Summ. J. 11; Report

of Dr. John D. Pratt, Ph.D., P.E., Ex. 1 at pp. 57, 60–61.) Dr. Pratt referred to certain images in opining that the accused product infringes Claim 7 of the ‘012 Patent. Regarding “Infringement Evidence” of Claim 7, Dr. Pratt’s report states that “[r]eferring to Figures 1 & 2 [pictured below]: The Series 46 fasteners include a screw (1) with a threaded shaft portion (5) having a head portion (2) having a top surface (3), bottom surface (4) and **annular chamfer (21)** peripheral to the bottom surface (4).” (Pratt Rpt. at 57, 60–61) (emphasis added).

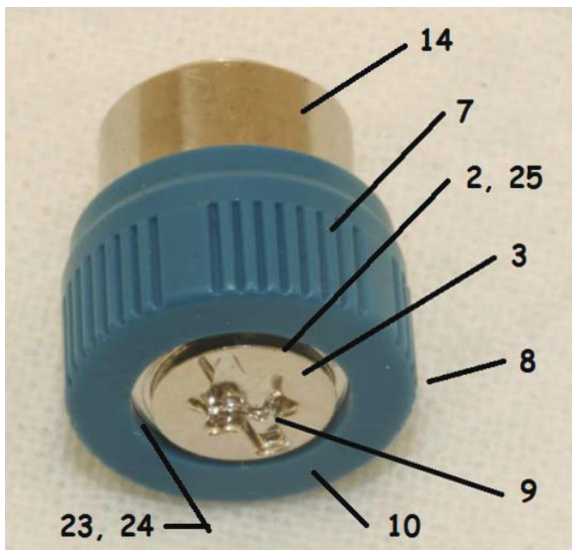

(Fig. 1)

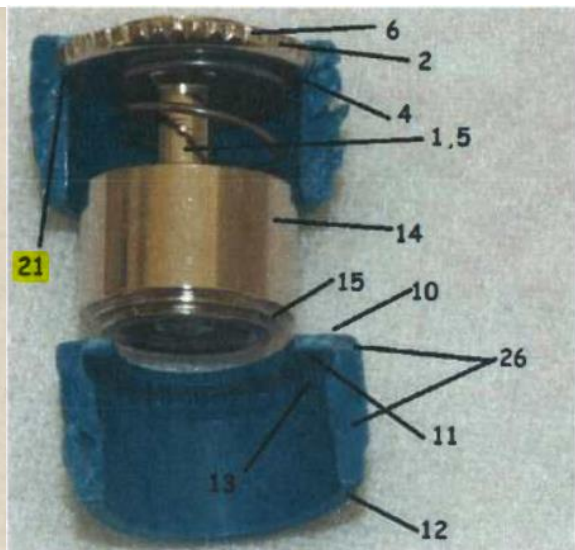

(Fig. 2)

Fivetech disputes the sufficiency of Dr. Pratt’s expert report, arguing that it does not establish the absence of a materially disputed fact with respect to the chamfer limitation. Fivetech stresses that if the accused product really did have a chamfered edge, Dr. Pratt could have and should have—but did not—measured the length of the edge, and ascertained the precise angle of the edge (in degrees). (Fivetech Resp. 3–4.) Because this information was not included in Dr. Pratt’s report, Fivetech insists that Dr. Pratt’s report is conclusory and merely “alleges” that a chamfered edge exists without supplying the necessary underlying undisputed factual evidence to support his conclusion. (*Id.* at 4, 12–13.) Additionally, Fivetech asserts that it is not indisputably discernable from the drawings and/or photographs submitted to this Court (and

relied upon by Dr. Pratt) whether or not the edge depicted is chamfered, as Southco maintains, or rounded, as Fivetech maintains. (Id. at 14.)

In reviewing Figures 1 and 2 above, it appears that the alleged annular chamfer limitation is not even depicted in Figure 1. As it relates to Figure 2, I agree with Fivetech that a reasonable jury could decline to find the annular chamfer limitation literally present based on this image. As Fivetech points out, Dr. Pratt's report did not set forth any specific measurements for the length and/or the angle of the alleged annular chamfer when he concluded that it is in fact present in the accused product.⁷ His Report cites to these images as "Infringement Evidence," but—when viewed in the light most favorable to Fivetech—a reasonable jury could conclude that the Report does not adequately explain *how* or *why* the annular chamfer limitation is present.

Next, Southco cites to the following figure in support of its position that the annular chamfer limitation is literally present in Fivetech's accused product:

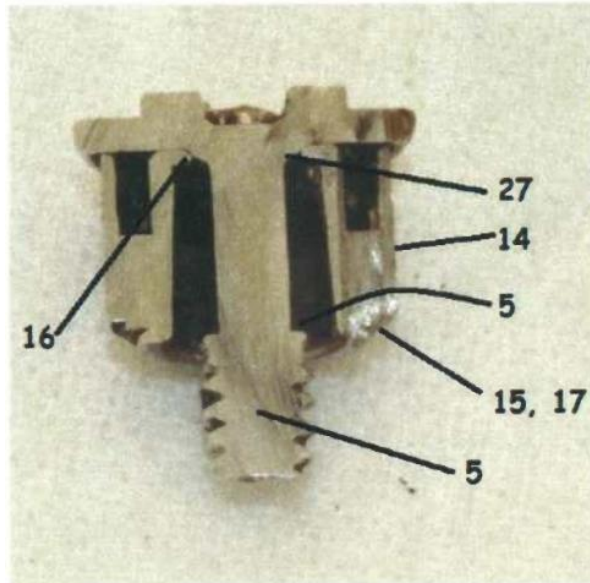

⁷ Southco further relies upon another "illustration" of the accused product in support of its argument. The diagrams, which were created in reference to Fivetech's manufacturing process, arguably depict a chamfer. However, like Dr. Pratt's Report, there are no accompanying mathematical measurements corroborating the length of the alleged chamfer, or the degree/angle of the alleged chamfer.

This image was also included in Dr. Pratt's Report, but was not cited as evidence of infringement with respect to the annular chamfer limitation. Nevertheless, Southco maintains that this image also indisputably reflects that the chamfer is present. Once again, when viewed in the light most favorable to Fivetech, I conclude that a reasonable jury could decline to find the chamfer limitation met based on this image.

Ultimately, viewing the evidence of record in the light most favorable to Fivetech, I cannot conclude, as a matter of law, that a reasonable jury would only reach one conclusion as to the literal presence of an annular chamfer in the accused product. Therefore, Southco's motion for partial summary judgment will be denied.

C. Southco's Motion to Strike Fivetech's Untimely Cross Motion for Summary Judgment of Noninfringement & Invalidity

Fivetech simultaneously filed a cross motion for summary judgment of noninfringement (which also includes additional invalidity arguments) with its response in opposition to Southco's partial motion for summary judgment of infringement. Fivetech's cross motion was filed approximately one month after the deadline for filing such motions as set out in my scheduling order. Fivetech never requested an extension of this deadline, nor did it seek leave to file this motion. As such, Southco moved to strike Fivetech's untimely submission. Fivetech does not dispute that its cross motion was filed after the deadline established by this Court's scheduling order. (Fivetech Resp. in Opp. to Southco Mot. to Strike 2 n.1, 16.)

In support of its motion to strike, Southco cites to Federal Rule of Civil Procedure 16(f)(1)(C), which states in relevant part: "[o]n motion or on its own, the court may issue any just orders . . . if a party or its attorney . . . fails to obey a scheduling or other pretrial order." (Southco Mot. to Strike 5.) Additionally, Rule 16(f)(2) provides that "[i]nstead of or in addition to any other sanction, the court *must* order the party, its attorney, or both to pay the reasonable

expenses—including attorney's fees—incurred because of any noncompliance with this rule, *unless* the noncompliance was substantially justified or other circumstances make an award of expenses unjust.” (emphasis added).

The United States Court of Appeals for the Third Circuit has instructed that, “[a]s the plain language of Rule 16(f) indicates, monetary sanctions for noncompliance with Rule 16 pretrial orders are *required* and appropriate absent a showing that the violation was ‘substantially justified’ or the award of expenses is ‘unjust’ under the circumstances of the case.” Tracinda Corp. v. DaimlerChrysler AG, 502 F.3d 212, 240–41 (3d Cir. 2007) (emphasis added); *see also* Rorrer v. Cleveland Steel Container, 564 F. App'x 642, 644 (3d Cir. 2014). “Substantial justification exists where there is a ‘genuine dispute concerning compliance.’” Rorrer v. Cleveland Steel Container Corp., 2010 WL 3719092, at *3 (E.D. Pa. Sept. 20, 2010) (citations omitted). “Whether a sanction is ‘unjust’ requires a ‘consideration of the degree of the sanction in light of the severity of the transgression which brought about the failure to [comply].’” Rorrer, 564 F. App'x at 644 (quoting Tracinda Corp., 502 F.3d at 241)).

It is undisputed that Fivetech filed an untimely cross motion for summary judgment. Moreover, Fivetech devotes just three (3) pages of its eighteen-page (18) response in opposition to Southco’s motion to strike to explaining why Southco’s motion to strike should be denied. Fivetech offers no substantial reasons to justify its tardiness. (Fivetech Resp. in Opp. to Southco Mot. to Strike 16–18.) There simply is no genuine dispute concerning noncompliance with this Court’s clear scheduling order that would qualify as “substantial justification.”

Regarding whether an award of expenses would be “unjust”, I reiterate that Fivetech never sought leave to file, nor did it request an extension of the deadlines. And this is not the first time that Fivetech has disregarded scheduling orders. Indeed, the Federal Circuit found that Judge McLaughlin’s reliance on Fivetech’s untimely expert report when granting summary

judgment of noninfringement was an abuse of discretion—given that it was only produced at summary judgment (after the deadline for expert discovery had expired), and because Southco did not have an opportunity to depose Fivotech’s expert. See Southco, Inc. v. Fivotech Tech. Inc., 611 F. App’x 681, 688 (Fed. Cir. 2015) (“Fivotech did not disclose Dr. Dornfeld’s opinion in an expert report as required by both the Federal Rules of Civil Procedure and the district court’s scheduling order. . . . Accordingly, Southco moved to strike the Dornfeld Declaration as untimely[.] . . . We hold that the district court clearly erred in finding Southco was not prejudiced. . . . The district court abused its discretion by failing to give Southco an opportunity to depose Dr. Dornfeld, relying on his declaration, and then faulting Southco for failing to rebut his opinion.”). Thus, I conclude that awarding Southco reasonable expenses for preparing its current motion to strike would not be “unjust” under the circumstances.

For all these reasons, and pursuant to Federal Rule of Civil Procedure 16(f), I will grant Southco’s motion to strike Fivotech’s untimely cross motion for summary judgment. I will further order Fivotech’s counsel to pay the “reasonable expenses” (i.e., attorneys’ fees) incurred by Southco in preparing its motion to strike.

IV. CONCLUSION

For the reasons explained above: Fivotech’s motion for summary judgment of invalidity of the ‘012 Patent is denied; Southco’s partial motion for summary judgment of infringement of Claim 7 of the ‘012 Patent is denied; Southco’s motion to strike Fivotech’s untimely cross motion for summary judgment is granted, and Fivotech’s counsel shall pay the reasonable expenses incurred by Southco in preparing its motion to strike.

An appropriate Order follows.