

**IN THE UNITED STATES DISTRICT COURT
FOR THE EASTERN DISTRICT OF TEXAS
MARSHALL DIVISION**

DYNOCOM INDUSTRIES, INC.,	§	
	§	
Plaintiff,	§	
	§	
v.	§	No. 2:16-CV-00553-JRG-RSP
	§	
MAINLINE AUTOMOTIVE EQUIPMENT	§	
PTY. LTD. T/A MAINLINE DYOLOG	§	
DYNAMOMETERS, et al.,	§	
	§	
Defendants.	§	

MEMORANDUM OPINION AND ORDER ON CLAIM CONSTRUCTION

On June 8, 2017, the Court held a hearing to determine the proper construction of the disputed claim terms in United States Patent No. 8,505,374 (“the ’374 Patent”). The Court has considered the arguments made by the parties at the hearing and in their claim construction briefs. Dkt. Nos. 52, 54, & 57.¹ The Court has also considered the intrinsic evidence and made subsidiary factual findings about the extrinsic evidence. *See Phillips v. AWH Corp.*, 415 F.3d 1303, 1314 (Fed. Cir. 2005); *Teva Pharm. USA, Inc. v. Sandoz, Inc.*, 135 S. Ct. 831, 841 (2015). The Court issues this Memorandum and Order on Claim Construction in light of these considerations.

¹ Citations to the parties’ filings are to the filing’s number in the docket (Dkt. No.) and pin cites are to the page numbers assigned through ECF.

TABLE OF CONTENTS

I. BACKGROUND 3

II. APPLICABLE LAW 5

III. CONSTRUCTION OF AGREED TERMS 8

IV. CONSTRUCTION OF DISPUTED TERMS 16

1. “co-axially rotate” 16

V. CONCLUSION 20

I. BACKGROUND

The '374 Patent was filed on December 10, 2009, issued on August 13, 2013, and is titled "Portable On Vehicle Dynamometer." The specification states that "FIGS. 1 and 2 are perspective views of a portable on-vehicle dynamometer ('POD') 12 for coupling directly to an axle of the vehicle to measure the power output of the axle." '374 Patent at 2:20–22.

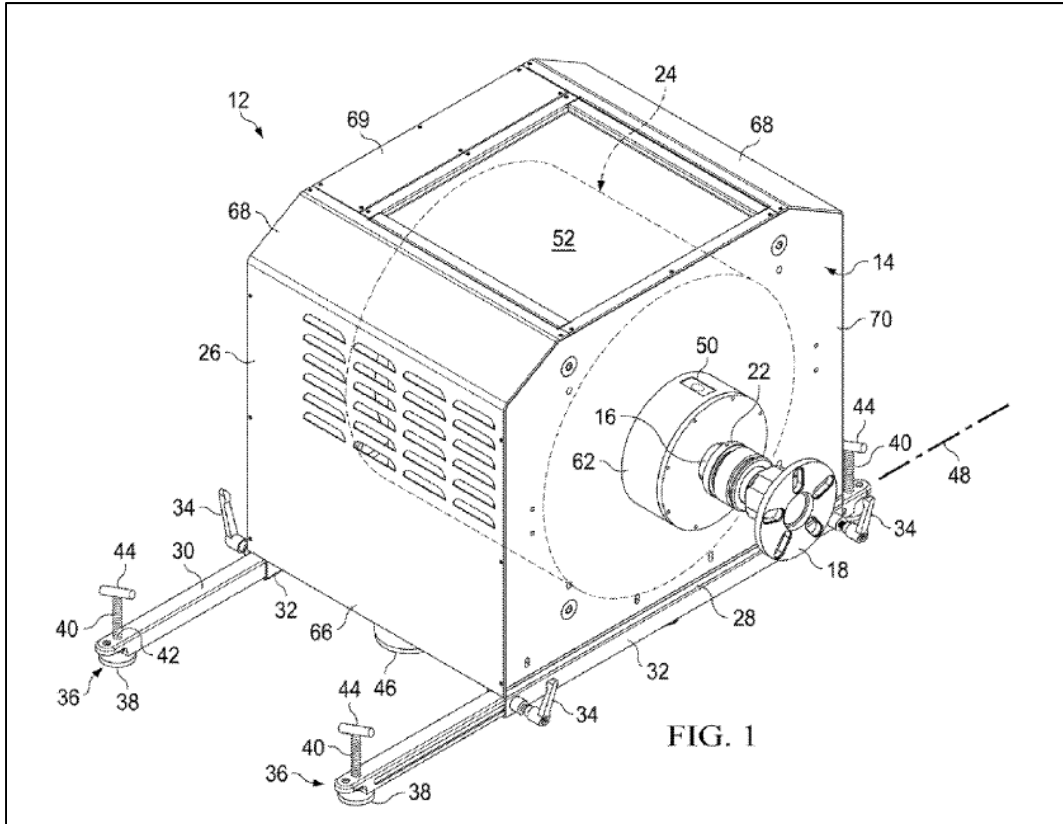

Id. at Figure 1. The specification describes POD 12 as having "a housing 14 from which extends a load shaft 16." *Id.* at 2:23–24. The specification adds that "[t]he load shaft 16 is secured with a hub coupling 18, a universal joint 20, and a quick connect 22 to an eddy current brake 24." *Id.* at 2:24–26. The specification further describes Figures 3 as "a perspective view of the POD 12 with two cover panels 66 and 68 removed." *Id.* at 2:35–36.

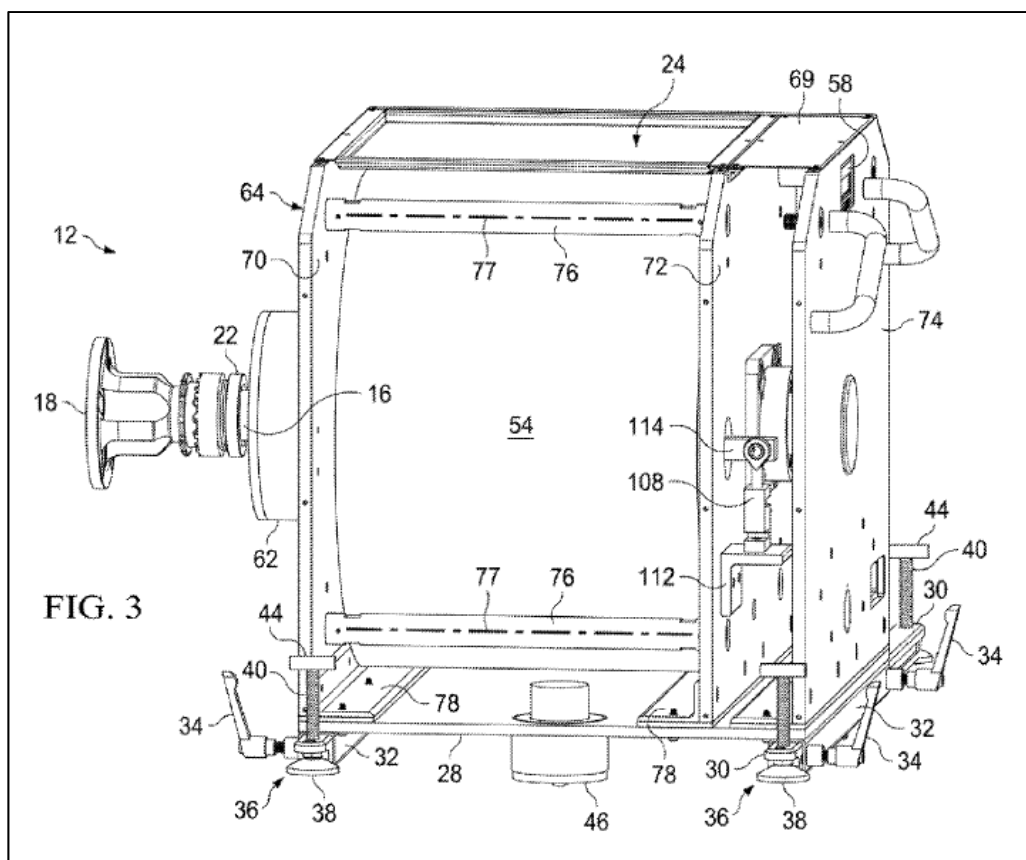

Id. at Figure 3. The specification states that “[t]he housing 14 defines an enclosure 26 having a base 28,” and that “[t]he base 28 is preferably provided by a rigid steel plate.” *Id.* at 2:36–38. The specification discloses that “[t]wo receiver tubes 32 are mounted to opposite ends of a lower side of the base 28 and extend in parallel in longitudinal alignment.” *Id.* at 2:38–40. The specification states that “[f]our support arms 30 extend outward from open ends of the receiver tubes 32,” and that “[t]he four support arms 30 have longitudinal axes 48 which extend parallel to a major plane of the steel plate providing the base 28.” *Id.* at 2:40–44. The specification further states that “[a]rm locks 34 are provided for securing the support arms 30 in retracted and in extended positions,” and that “[f]eet assembly 36 are mounted to the outward ends of the support arms 30 and extend downward for vertically engaging a floor or a ground surface located beneath the POD 12.” *Id.* at 2:44–48. Finally, the specification discloses that “[t]wo roller assemblies 46 are mounted to the bottom

of the base plate 28, spaced apart in intermediate positions between the support arms 30.” *Id.* at 2:61–64.

Claim 1 of the ’374 Patent is an exemplary claim and recites the following elements (disputed term in italics):

1. A portable on vehicle dynamometer for determining power output from a drive shaft, comprising:
 - a rigid frame;
 - a load shaft rotatably coupled to said rigid frame;
 - an eddy current brake having a stator connected to said rigid frame, and a rotor connected to said load shaft;
 - a hub coupling secured to a first end of said load shaft and connected directly to the drive shaft for transferring power to the load shaft, wherein said hub coupling, said drive shaft and said load shaft *co-axially rotate*;
 - said rigid frame having two outwardly extending support arms, and arm locks which secure said outwardly extending support arms in fixed positions;
 - support feet assemblies mounting to respective ones of outer ends of said support arms; and
 - two roller assemblies mounted to a lower end of said rigid frame, providing multidirectional movement of said dynamometer.

II. APPLICABLE LAW

A. Claim Construction

“It is a ‘bedrock principle’ of patent law that ‘the claims of a patent define the invention to which the patentee is entitled the right to exclude.’” *Phillips v. AWH Corp.*, 415 F.3d 1303, 1312 (Fed. Cir. 2005) (en banc) (quoting *Innova/Pure Water Inc. v. Safari Water Filtration Sys., Inc.*, 381 F.3d 1111, 1115 (Fed. Cir. 2004)). To determine the meaning of the claims, courts start by considering the intrinsic evidence. *Id.* at 1313; *C.R. Bard, Inc. v. U.S. Surgical Corp.*, 388 F.3d

858, 861 (Fed. Cir. 2004); *Bell Atl. Network Servs., Inc. v. Covad Commc'ns Group, Inc.*, 262 F.3d 1258, 1267 (Fed. Cir. 2001). The intrinsic evidence includes the claims themselves, the specification, and the prosecution history. *Phillips*, 415 F.3d at 1314; *C.R. Bard, Inc.*, 388 F.3d at 861. The general rule—subject to certain specific exceptions discussed *infra*—is that each claim term is construed according to its ordinary and accustomed meaning as understood by one of ordinary skill in the art at the time of the invention in the context of the patent. *Phillips*, 415 F.3d at 1312–13; *Alloc, Inc. v. Int'l Trade Comm'n*, 342 F.3d 1361, 1368 (Fed. Cir. 2003); *Azure Networks, LLC v. CSR PLC*, 771 F.3d 1336, 1347 (Fed. Cir. 2014) (“There is a heavy presumption that claim terms carry their accustomed meaning in the relevant community at the relevant time.”) (vacated on other grounds).

“The claim construction inquiry . . . begins and ends in all cases with the actual words of the claim.” *Renishaw PLC v. Marposs Societa' per Azioni*, 158 F.3d 1243, 1248 (Fed. Cir. 1998). “[I]n all aspects of claim construction, ‘the name of the game is the claim.’” *Apple Inc. v. Motorola, Inc.*, 757 F.3d 1286, 1298 (Fed. Cir. 2014) (quoting *In re Hiniker Co.*, 150 F.3d 1362, 1369 (Fed. Cir. 1998)). First, a term’s context in the asserted claim can be instructive. *Phillips*, 415 F.3d at 1314. Other asserted or unasserted claims can also aid in determining the claim’s meaning, because claim terms are typically used consistently throughout the patent. *Id.* Differences among the claim terms can also assist in understanding a term’s meaning. *Id.* For example, when a dependent claim adds a limitation to an independent claim, it is presumed that the independent claim does not include the limitation. *Id.* at 1314–15.

“[C]laims ‘must be read in view of the specification, of which they are a part.’” *Id.* (quoting *Markman v. Westview Instruments, Inc.*, 52 F.3d 967, 979 (Fed. Cir. 1995) (en banc)). “[T]he specification ‘is always highly relevant to the claim construction analysis. Usually, it is dispositive;

it is the single best guide to the meaning of a disputed term.” *Id.* (quoting *Vitronics Corp. v. Conceptronic, Inc.*, 90 F.3d 1576, 1582 (Fed. Cir. 1996)); *Teleflex, Inc. v. Ficosa N. Am. Corp.*, 299 F.3d 1313, 1325 (Fed. Cir. 2002). But, “[a]lthough the specification may aid the court in interpreting the meaning of disputed claim language, particular embodiments and examples appearing in the specification will not generally be read into the claims.” *Comark Commc’ns, Inc. v. Harris Corp.*, 156 F.3d 1182, 1187 (Fed. Cir. 1998) (quoting *Constant v. Advanced Micro-Devices, Inc.*, 848 F.2d 1560, 1571 (Fed. Cir. 1988)); *see also Phillips*, 415 F.3d at 1323. “[I]t is improper to read limitations from a preferred embodiment described in the specification—even if it is the only embodiment—into the claims absent a clear indication in the intrinsic record that the patentee intended the claims to be so limited.” *Liebel-Flarsheim Co. v. Medrad, Inc.*, 358 F.3d 898, 913 (Fed. Cir. 2004).

The prosecution history is another tool to supply the proper context for claim construction because, like the specification, the prosecution history provides evidence of how the U.S. Patent and Trademark Office (“PTO”) and the inventor understood the patent. *Phillips*, 415 F.3d at 1317. However, “because the prosecution history represents an ongoing negotiation between the PTO and the applicant, rather than the final product of that negotiation, it often lacks the clarity of the specification and thus is less useful for claim construction purposes.” *Id.* at 1318; *see also Athletic Alternatives, Inc. v. Prince Mfg.*, 73 F.3d 1573, 1580 (Fed. Cir. 1996) (ambiguous prosecution history may be “unhelpful as an interpretive resource”).

Although extrinsic evidence can also be useful, it is “less significant than the intrinsic record in determining the legally operative meaning of claim language.” *Phillips*, 415 F.3d at 1317 (quoting *C.R. Bard, Inc.*, 388 F.3d at 862). Technical dictionaries and treatises may help a court understand the underlying technology and the manner in which one skilled in the art might

use claim terms, but technical dictionaries and treatises may provide definitions that are too broad or may not be indicative of how the term is used in the patent. *Id.* at 1318. Similarly, expert testimony may aid a court in understanding the underlying technology and determining the particular meaning of a term in the pertinent field, but an expert’s conclusory, unsupported assertions as to a term’s definition are entirely unhelpful to a court. *Id.* Generally, extrinsic evidence is “less reliable than the patent and its prosecution history in determining how to read claim terms.” *Id.* The Supreme Court recently explained the role of extrinsic evidence in claim construction:

In some cases, however, the district court will need to look beyond the patent’s intrinsic evidence and to consult extrinsic evidence in order to understand, for example, the background science or the meaning of a term in the relevant art during the relevant time period. *See, e.g., Seymour v. Osborne*, 11 Wall. 516, 546 (1871) (a patent may be “so interspersed with technical terms and terms of art that the testimony of scientific witnesses is indispensable to a correct understanding of its meaning”). In cases where those subsidiary facts are in dispute, courts will need to make subsidiary factual findings about that extrinsic evidence. These are the “evidentiary underpinnings” of claim construction that we discussed in *Markman*, and this subsidiary factfinding must be reviewed for clear error on appeal.

Teva Pharm. USA, Inc. v. Sandoz, Inc., 135 S. Ct. 831, 841 (2015).

III. CONSTRUCTION OF AGREED TERMS

The parties agreed to the construction of the following terms/phrases:

Claim Term/Phrase	Agreed Construction
multidirectional movement [of said dynamometer]	movement [of said dynamometer] along a plurality of intersecting lines
sufficient mass	a mass high enough
without power	without utilizing an external source of electricity
quick disconnect coupler	a coupling device capable of being uncoupled without the use of tools

Dkt. No. 46 at 2. In view of the parties’ agreement on the proper construction of the identified terms, the Court **ADOPTS** the parties’ agreed constructions.

During the claim construction hearing, the parties agreed to the construction of the following terms/phrases:

Claim Term/Phrase	Agreed Construction
portable	capable of being moved between a plurality of locations for operation or storage
connected directly	fixed securely
outwardly extending support arms, and arm locks	<p>“outwardly extending support arms” means “support arms that are capable of extending outward from the frame to provide a wider footprint”</p> <p>“arm locks” means “devices capable of securing the support arms in a fixed position”</p>
fixed positions	two or more fixed positions
support feet assemblies	two or more assemblies that engage the floor or ground surface located beneath the dynamometer for support
two roller assemblies	two assemblies that are beneath the dynamometer for support and are capable of providing multidirectional movement of the dynamometer
mounting to [respective one of] outer ends [of said] support arms	mounted to the outer end of each support arm
mounted to a lower end [of said rigid frame]	plain and ordinary meaning
drive shaft hub	wheel hub of the drive shaft

Regarding the term “**portable,**” the Court preliminarily construed the term to mean “capable of being moved to the drive shaft.” The parties agreed during the claim construction hearing to

construe the term to mean “capable of being moved between a plurality of locations for operation or storage.” The Court finds that the parties’ agreed construction is supported by the intrinsic evidence. In describing the prior art, the Background of the Invention section states that “typical automotive chassis type dynamometers” are “either [] buried in a garage floor, or that a rack is provided to suspend a vehicle above the dynamometer.” ’374 Patent at 1:14–22. The specification adds that “[s]uch configurations take up considerable space, and may not be often used,” and that “[c]onsiderable garage space is also used when hydraulic dynamometers are used, due to the ancillary hydraulic equipment required.” *Id.* at 1:22–25.

In contrast, the specification states “the advantages of this invention provides a compact dynamometer *which may be stored in small spaces when not in use.*” *Id.* at 5:44–46 (emphasis added). Similarly, the specification states that “[t]he support arms can be folded or retracted when not in use *to allow for compact storage,*” and that “[t]he unit is compact enough to allow doors on a vehicle to open and close when bolted on the vehicle.” *Id.* at 5:56–6:14 (emphasis added). Thus, the intrinsic evidence indicates the disclosed portable dynamometer is “capable of being moved between a plurality of locations for operation or storage.” Accordingly, the Court **ADOPTS** the parties’ agreed constructions for the term **“portable.”**

Regarding the term **“connected directly,”** the parties agreed to the Court’s preliminary construction of “fixed securely.” The agreed construction is found in the intrinsic evidence. Specifically, the Detailed Description of the Invention section states “[a] hub of a wheel of a vehicle may be *connected directly* to the hub coupling 18 for connecting the vehicle directly to the POD 12 to determine the power output of the vehicle, without requiring jack stands and the like to support the vehicle over a conventional type dynamometer.” *Id.* at 2:29–34 (emphasis added). Likewise, the specification states the portable on-vehicle dynamometer (“POD”) is “for coupling

directly to an axle of the vehicle to measure the power output of the axle.” *Id.* at 2:20–22. Thus, to measure the power output of the vehicle, the recited “hub coupling” must be fixed securely to the drive shaft. Indeed, the parties originally agreed that “connected directly” meant at least “fixed securely.”

Defendants originally argued that the intrinsic evidence shows the hub coupling (18) is intended to “directly connect” to the axle with no intervening parts. (Dkt. No. 54 at 9). Defendants also argued that the applicant used this direct connection to distinguish the claims from the prior art. (Dkt. No. 54 at 9). The Court disagrees that there was a clear and unambiguous disclaimer in the prosecution history. During prosecution the examiner stated the newly filed claims were “allowable over the prior art” because of the limitation that “the hub coupling is secured to the load shaft and connected directly to the drive shaft for transferring power to the load shaft, wherein ‘said hub coupling, said drive shaft and said load shaft co-axially rotate’.” (Dkt. No. 57-1 at 8). In response to the arguments made by the patentee, the examiner noted the prior-art patent (D’Angelo) shows a pulley and belt, and interpreted these to correspond to the “hub” and “hub coupling” language in the claims. *Id.* at 9.

Contrary to the Defendants’ assertion, the patentee did not clearly and unambiguously argue “connected directly” was the distinguishing feature. In addition to submitting claims that recited “connected directly,” the patentee also submitted claims that did not recite “connected directly.” For example, claim 1 recites “a hub coupling secured to a first end of said load shaft and connecting to the drive shaft for transferring power to the load shaft.” (Dkt. No. 54-6 at 9). In contrast, claim 14 recites “a hub coupling secured to a first end of said load shaft and connected directly to the drive shaft for transferring power to the load shaft.” *Id.* at 13. More importantly, claim 14 further recites “wherein said hub coupling, said drive shaft and said load shaft co-axially

rotate.” *Id.* It was the co-axial rotation limitation that the examiner emphasized and quoted in the “Allowable Subject Matter.” Indeed, Defendants argue in their brief that “the examiner *allowed* the claims based solely on the inclusion of ‘co-axially rotate.’” (Dkt. No. 54 at 13) (emphasis in original). Thus, the Court is not persuaded the prosecution history indicates “connected directly” means with no intervening parts. To the extent that Defendants argue otherwise, the Court rejects this argument. Accordingly, the Court **ADOPTS** the parties’ agreed constructions for the term **“connected directly.”**

Regarding the phrase **“outwardly extending support arms, and arm locks,”** the parties agreed to the Court’s preliminary constructions for the terms “outwardly extending support arms,” and “arm locks.” The agreed constructions are found in the intrinsic evidence. The specification indicates the support arms extend outward, as recited in the claim, and also provide a wider footprint. Specifically, the specification states that “[s]upport arms are extended to provide a wider footprint for the POD and assist in providing leverage for the torsional forces when in use.” ’374 Patent at 5:54–56. Similarly, the specification indicates the “[f]our support arms 30 extend outward from open ends of the receiver tubes 32.” *Id.* at 2:40–41. In describing the embodiment illustrated in Figure 14, the specification states that “[t]he POD 190 has two support legs 194 which are pivotally secured within a vertically disposed channel for storage, and then which may be extended downward for supporting the POD 190.” *Id.* at 5:35–39. Thus, the intrinsic evidence indicates that the “outwardly extending support arms” are “support arms that are capable of extending outward from the frame to provide a wider footprint.” Accordingly, the Court **ADOPTS** the parties’ agreed construction for the term **“outwardly extending support arms.”**

The specification further states that “[a]rm locks 34 are provided for securing the support arms 30 in retracted and in extended positions.” *Id.* at 2:44–45. In describing the embodiment

illustrated in Figure 14, the specification states that “[s]upport leg locks 196 are threaded members which are tightened to secure the support legs 194 in downward positions during use of the POD 190, and to retain the support legs 194 in storage positions.” *Id.* at 5:40–42. Claim 1 further recites that the arm locks secure the support arms in “fixed positions.” Thus, the intrinsic evidence indicates that the “arm locks” are “devices capable of securing the support arms in a fixed position.” Accordingly, the Court **ADOPTS** the parties’ agreed construction for the term “**arm locks.**”

Regarding the term “**fixed positions,**” the parties agreed to the Court’s preliminary construction of “two or more fixed positions.” The agreed construction is found in the intrinsic evidence. The specification states that the “[f]our support arms 30 extend outward from open ends of the receiver tubes 32.” *Id.* at 2:40–41. In describing the embodiment illustrated in Figure 14, the specification further states that “[t]he POD 190 has two support legs 194 which are pivotally secured within a vertically disposed channel for storage, and then which may be extended downward for supporting the POD 190.” *Id.* at 5:35–39. The specification also states that “[a]rm locks 34 are provided for securing the support arms 30 in retracted and in extended positions.” *Id.* at 2:44–45. Likewise, the specification states that the “[s]upport leg locks 196 are threaded members which are tightened to secure the support legs 194 in downward positions during use of the POD 190, and to retain the support legs 194 in storage positions.” *Id.* at 5:40–42. Thus, the intrinsic evidence indicates that “fixed positions” means “two or more positions” (*e.g.*, a retracted position and an extended position). Accordingly, the Court **ADOPTS** the parties’ agreed construction for the term “**fixed positions.**”

Regarding the term “**support feet assemblies,**” the parties agreed to the Court’s preliminary construction of “two or more assemblies that engage the floor or ground surface located beneath the dynamometer for support.” The agreed construction is found in the intrinsic evidence.

The specification states that “[f]eet assembly 36 are mounted to the outward ends of the support arms 30 and extend downward for vertically engaging a floor or a ground surface located beneath the POD 12.” *Id.* at 2:45–48. Thus, the intrinsic evidence indicates that the “support feet assemblies” engage the floor or ground surface. Accordingly, the Court **ADOPTS** the parties’ agreed construction for the term **“support feet assemblies.”**

Regarding the term **“two roller assemblies,”** the Court preliminarily construed the term to mean “two assemblies that engage the floor or ground surface located beneath the dynamometer for support and are capable of providing multidirectional movement of the dynamometer.” The parties agreed during the claim construction hearing to construe the term to mean “two assemblies that are beneath the dynamometer for support and are capable of providing multidirectional movement of the dynamometer.” The agreed construction is supported by the intrinsic evidence. Specifically, the Summary of the Invention states that “[t]wo roller assemblies are mounted to a lower end of the rigid frame and provide for multidirectional movement of the dynamometer.” *Id.* at 1:40–42. Thus, the roller assemblies provide for multidirectional movement of the dynamometer. The specification also states that “[t]wo roller assemblies 46 are mounted to the bottom of the base plate 28, spaced apart in intermediate positions between the support arms 30.” *Id.* at 2:61–64. In other words, the roller assemblies are beneath the dynamometer for support. Thus, the intrinsic evidence indicates the roller assemblies are “two assemblies that are beneath the dynamometer for support and are capable of providing multidirectional movement of the dynamometer.” Accordingly, the Court **ADOPTS** the parties’ agreed construction for the term **“two roller assemblies.”**

Regarding the phrase **“mounting to [respective one of] outer ends [of said] support arms,”** the parties agreed to the Court’s preliminary construction of “mounted to the outer end of each support arm.” The agreed construction is found in the intrinsic evidence. The claim language

states that the support feet assemblies are mounted to the outer ends of each support arm. Likewise, the specification states that that feet assemblies “are mounted to the *outward ends* of the support arms 30 and extend downward for vertically engaging a floor or a ground surface located beneath the POD 12.” *Id.* at 2:45–48 (emphasis added). Thus, the intrinsic evidence indicates that the “mounting to [respective one of] outer ends [of said] support arms” means “mounted to the outer end of each support arm.” Accordingly, the Court **ADOPTS** the parties’ agreed construction for the phrase **“mounting to [respective one of] outer ends [of said] support arms.”**

Regarding the phrase **“mounted to a lower end [of said rigid frame],”** the parties agreed that the phrase should be given its plain and ordinary meaning. The claim language is unambiguous and easily understandable by a jury. “Mounted to a lower end” means mounted to a lower end. For example, the specification states that the “[t]wo roller assemblies are mounted to a lower end of the rigid frame and provide for multidirectional movement of the dynamometer.” *Id.* at 2:61–64. Thus, the intrinsic evidence indicates that the phrase “mounted to a lower end [of said rigid frame]” should be given its plain and ordinary meaning. Accordingly, the Court **ADOPTS** the parties’ agreed construction for the phrase **“mounted to a lower end [of said rigid frame].”**

Regarding the term **“drive shaft hub,”** the parties agreed to the Court’s preliminary construction of “wheel hub of the drive shaft.” The agreed construction is supported by the intrinsic evidence. The “drive shaft hub” is not illustrated in the specification, and is recited for the first time in dependent claim 6. Opposite the drive shaft and drive shaft hub, is the recited “load shaft” and “hub coupling.” Claim 6 focuses on the load shaft side, and further recites that it includes “a quick-disconnect coupler for securing a hub adapter” to the load shaft. The claim further recites that the “hub adapter” is mated to the “drive shaft adapter.” Thus, neither the claims nor the specification discuss or illustrate a “drive shaft hub.” However, claim 1 recites that the “hub coupling”

is “secured to a first end of said load shaft.” Therefore, a person of ordinary skill would understand that the “mating” wheel hub would be “secured to the drive shaft.” Thus, the intrinsic evidence indicates that the “drive shaft hub” is a “wheel hub of the drive shaft.” Accordingly, the Court **ADOPTS** the parties’ agreed construction for the term **“drive shaft hub.”**

IV. CONSTRUCTION OF DISPUTED TERMS

The parties’ dispute focuses on the meaning and scope of one term in the ’374 Patent.

A. “co-axially rotate”

Disputed Term	Plaintiff’s Proposal	Defendants’ Proposal
co-axially rotate	the axis of rotation of two rotating structures aligned to a degree sufficient to transfer rotation	rotate on a common axis

1. The Parties’ Positions

The parties agree the claim recites two rotating shafts, the vehicle’s shaft (*i.e.*, “the drive shaft”) and the dynamometer’s shaft (*i.e.*, “the load shaft”). But the parties dispute the degree of axial alignment required between these two rotating shafts. Defendants contend that “co-axially rotate” requires the two shafts to “rotate on a common axis.” Plaintiff contends that “co-axially rotate” does not require perfect alignment. (Dkt. No. 52 at 12) (citing ’374 Patent at 6:7–10, 4:50–53, Fig. 9). According to Plaintiff, Defendants’ construction introduces new terms that would require further construction and cause confusion because it is not supported by the intrinsic record. (Dkt. No. 52 at 11). Plaintiff contends the term “common axis” appears nowhere in the intrinsic evidence. *Id.*

Defendants respond that the relationship of the hub coupling, the drive shaft, and the load shaft is consistently depicted in such a way that they rotate on a common axis. (Dkt. No. 54 at 10)

(citing '374 Patent at 3:51–53, Fig. 4). Defendants argue the extrinsic record also supports their construction of “co-axially rotate.” (Dkt. No. 54 at 11) (citing Dkt. No. 54-8, Dkt. No. 54-9, Dkt. No. 54-10). Defendants further argue there is no support in the intrinsic record for Plaintiff’s construction of “co-axially rotate.” (Dkt. No. 54 at 12). According to Defendants, Plaintiff’s construction does not require “any co-axiality,” and would encompass both co-axial and non-co-axial rotation. *Id.* Defendants also contend Plaintiff’s construction is at odds with the prosecution history of the '374 Patent. *Id.* (citing Dkt. No. 54-4, Dkt. No. 54-5, Dkt. No. 54-6, Dkt. No. 54-7). Defendants argue it is clear from the intrinsic record that “co-axially rotate” cannot mean that the three structures can rotate on different axes so long as power is transferred between them. (Dkt. No. 54 at 13).

Plaintiff replies the plain and ordinary meaning of the term “co-axially rotate” requires some degree of tolerance, and that there is no requirement the axes of the rotating parts be absolutely perfectly aligned. (Dkt. No. 57 at 8). Plaintiff also argues that construing this term as broadly as Defendants suggest could potentially render the claims invalid. *Id.* at 9. Plaintiff further contends Defendants admit the prior art “disclosed a dynamometer wherein the drive shaft and the load shaft were offset.” *Id.* (citing Dkt. No. 54 at 8). Plaintiff argues that Defendants go too far by alleging that the claims were allowed because the rotating parts were perfectly aligned. (Dkt. No. 57 at 9). According to Plaintiff, there is a degree of alignment within the term co-axial that avoids the prior art but is also less than perfect alignment. *Id.*

For the following reasons, the Court finds that the term “**co-axially rotate**” should be construed to mean “**rotate on a common axis.**”

2. Analysis

The term “co-axially rotate” appears in claim 1 of the ’374 Patent. The Court finds that “co-axially rotate” means the recited hub coupling, the drive shaft, and the load shaft “rotate on a common axis.” However, the specification indicates the axis of the recited shaft may not be perfectly aligned. For example, the specification describes Figure 9 as “a perspective view of a double universal joint 20 having two universal joints 182 in series, extending along a singular axis to provide two degrees of movement *for misalignment*.” ’374 Patent at 4:50–53 (emphasis added). Similarly, the specification further acknowledges the POD may need to be adjusted for misalignment. *Id.* at 6:7–10 (“The POD can change angle to allow for misalignment in the vehicles suspension via leveling pads/feet and tilting or rotating among its castors/ball castors, and such.”). Thus, a person of ordinary skill in the art would understand that although the parts are required to rotate on a “common axis,” the “common axis” is one that includes an alignment tolerance suitable for the dynamometer application.

Defendants argue the double universal joint illustrated in Figure 9 is only used in the embodiment illustrated in Figure 12. (Dkt. No. 54 at 12). Defendants further contend that Figure 12 illustrates the double universal joint (20) between connectors (162) and the hub coupling (18), and the hub coupling is in turn attached to a ninety-degree gear box (164), not the drive shaft as claim 1 requires. Defendants correctly describe Figure 12, but this does not mean the double universal joint is limited to that illustrated embodiment. Indeed, the description of Figure 9 does not mention Figure 12. Moreover, in describing Figure 1, the specification states that “[t]he load shaft 16 is secured with a hub coupling 18, a universal joint 20, and a quick connect 22 to an eddy current brake 24.” ’374 Patent at 2:24–26. Accordingly, the Court agrees “co-axially rotate” means “rotating on a common axis.” However, to the extent Defendants contend a “common axis” requires

the recited shafts to be perfectly aligned, the Court rejects this argument.²

The Court does not adopt Plaintiff's construction because it could be interpreted to encompass both co-axial and non-co-axial rotation. As described above, the patent examiner rejected the initial claims as anticipated by D'Angelo. (Dkt. No. 54-4 at 4). D'Angelo disclosed a dynamometer where the drive shaft and the load shaft were offset, and connected by a belt that transferred rotation between the structures. (Dkt. No. 54-5 at 3, Figure 4). In other words, the hub coupling, drive shaft, and load shaft disclosed in D'Angelo rotated on different axes, but were aligned so that power could still be transferred from the drive shaft, through the hub coupling, to the load shaft.

The original claims did not include the "co-axially rotate" limitation. In response to the rejection, the patentee added new claims that required the hub coupling, drive shaft, and load shaft all "co-axially rotate." (Dkt. No. 54-6 at 11, 13). In the Final Office Action, the examiner allowed the claims based on the inclusion of "co-axially rotate." (Dkt. No. 54-7 at 7). Thus, the intrinsic record indicates that "co-axially rotate" cannot mean that the three structures can rotate on different axes so long as power is transferred between them. Accordingly, the Court rejects Plaintiff's construction because it could encompass both co-axial and non-co-axial rotation. Finally, in reaching its conclusion, the Court has considered the extrinsic evidence submitted by the parties, and given it its proper weight in light of the intrinsic evidence.

3. Court's Construction

The Court construes "**co-axially rotate**" to mean "**rotate on a common axis.**"

² During the claim construction hearing, Defendants represented to the Court they do not contend "co-axially rotate" requires perfect alignment. The Court agrees that rotating on a common axis does not require "perfect" alignment, but determining the amount of allowable misalignment that would be considered a "common axis" is likely a fact question, and not a claim construction issue.

V. CONCLUSION

The Court adopts the constructions above for the disputed and agreed terms of the Asserted Patent. Furthermore, the parties should ensure all testimony that relates to the terms addressed in this Order is constrained by the Court's reasoning. However, in the presence of the jury the parties should not expressly or implicitly refer to each other's claim construction positions and should not expressly refer to any portion of this Order that is not an actual construction adopted by the Court. The references to the claim construction process should be limited to informing the jury of the constructions adopted by the Court.

SIGNED this 15th day of July, 2017.

ROY S. PAYNE
UNITED STATES MAGISTRATE JUDGE