

**IN THE UNITED STATES DISTRICT COURT
FOR THE EASTERN DISTRICT OF TEXAS
MARSHALL DIVISION**

UNILOC 2017 LLC,

Plaintiff,

v.

VERIZON COMMUNICATIONS, INC.
ET AL.,

Defendants.

Case No. 2:18-cv-00536-JRG

CLAIM CONSTRUCTION MEMORANDUM OPINION AND ORDER

Before the Court is the opening claim construction brief of UNILOC 2017 LLC (“Plaintiff”) (Dkt. No. 33), the response of Verizon Communications Inc., Cellco Partnership Inc. d/b/a Verizon Wireless, Verizon Business Network Services Inc. and Verizon Digital Media Services Inc. (collectively “Defendants”) (Dkt. No. 37), and the reply of Plaintiff (Dkt. No. 38). The Court held a hearing on the issues of claim construction and claim definiteness on February 7, 2020. Having considered the arguments and evidence presented by the parties at the hearing and in their briefing, the Court issues this Order.

Table of Contents

I. BACKGROUND 3

 A. The '712 Patent 3

 B. The '118 Patent 4

II. LEGAL PRINCIPLES 4

 A. Claim Construction 4

 B. Departing from the Ordinary Meaning of a Claim Term 7

 C. Definiteness Under 35 U.S.C. § 112, ¶ 2 (pre-AIA) / § 112(b) (AIA) 8

III. AGREED CONSTRUCTIONS..... 9

IV. CONSTRUCTION OF DISPUTED TERMS..... 10

 A. “resynchronization marker” 10

 B. “digital image” 17

 C. Preamble of Claim 1 of the '118 Patent..... 19

 D. “switch request” 23

 E. “the buffering step being controlled to transmit an I picture” 26

V. CONCLUSION 28

I. BACKGROUND

Plaintiff alleges infringement of two U.S. Patents: No. 6,628,712 (the “’712 Patent”) and No. 6,895,118 (the “’118 Patent”) (collectively, the “Asserted Patents”).

A. The ’712 Patent

The ’712 Patent is entitled Seamless Switching of MPEG Video Streams. The application leading to the ’712 Patent was filed on November 8, 2000 and the patent lists a priority claim to a foreign application filed on November 23, 1999. In general, the ’712 Patent is directed to technology for switching between streams of data, such as MPEG video streams.

The abstract of the ’712 Patent provides:

A switching device SW allows to switch from a first compressed data input stream IS1 to a second compressed data input stream IS2, resulting in a compressed data output stream OS. This switching device comprises a buffer system BS intended to store the data contained in the first and second input streams, and control means CONT which controls the storage of the input streams in the buffer system in order to switch, at a switch request SWR, from the first input stream to the second input stream, using a commutation device COM.

A transcoding system TS is intended to receive the data stream at the output of the commutation device and to provide the output stream in a seamless way. The use of a transcoding system allows to avoid an underflow or an overflow of the buffer of the decoder that will have to decode the output stream. Moreover, said transcoding system allows to encode the output stream at a bit rate R, where R may be different from the bit rate R1 of the first input stream and the bit rate R2 of the second input stream.

Claim 4 of the ’712 Patent, an exemplary method claim, provides:

4. A method of switching from a first compressed data input stream to a second compressed data input stream, resulting in a compressed data output stream, said method of switching comprising the steps of:

buffering, in which the data contained in the first and the second input stream are stored,

controlling the storage of the input streams during the buffering step in order to switch, at a switch request, from the first input stream to the second input stream,

transcoding the stream provided by the control step, the transcoding includes controlling occupancy of a buffer by feedback to DCT coefficient quantization in order to provide the output stream in a seamless way.

B. The '118 Patent

The '118 Patent is entitled Method of Coding Digital Image Based on Error Concealment. The application leading to the '118 Patent was filed on March 1, 2002 and the patent lists a priority claim to a foreign application filed on March 6, 2001. In general, the '118 Patent is directed to technology for coding digital images, such as MPEG video streams, that enables exclusion of macroblocks that can be reconstructed using error-concealment methods such as spatial and temporal error concealment.

The abstract of the '118 Patent provides:

The invention relates to a method of coding a digital image comprising macroblocks in a binary data stream, comprising an estimation step, for macroblocks, of a capacity to be reconstructed by an error concealment method, a decision step for excluding macroblocks from the coding, a decision to exclude a macroblock from coding being made on the basis of the capacity of such macroblock to be reconstructed and a step of inserting a resynchronization marker into the binary data stream following the exclusion of one or more macroblocks.

Claim 1 of the '118 Patent, an exemplary method claim, provides:

1. A method of coding a digital image comprising macroblocks in a binary data stream, the method comprising:
 - an estimation step, for macroblocks, of a capacity to be reconstructed via an error concealment method,
 - a decision step for macroblocks to be excluded from the coding, a decision to exclude a macroblock from coding being made on the basis of the capacity of such macroblock to be reconstructed,
 - characterized in that it also includes a step of inserting a resynchronization marker into the binary data stream after the exclusion of one or more macroblocks.

II. LEGAL PRINCIPLES

A. Claim Construction

“It is a ‘bedrock principle’ of patent law that ‘the claims of a patent define the invention to which the patentee is entitled the right to exclude.’” *Phillips v. AWH Corp.*, 415 F.3d 1303, 1312 (Fed. Cir. 2005) (en banc) (quoting *Innova/Pure Water Inc. v. Safari Water Filtration Sys., Inc.*,

381 F.3d 1111, 1115 (Fed. Cir. 2004)). To determine the meaning of the claims, courts start by considering the intrinsic evidence. *Id.* at 1313; *C.R. Bard, Inc. v. U.S. Surgical Corp.*, 388 F.3d 858, 861 (Fed. Cir. 2004); *Bell Atl. Network Servs., Inc. v. Covad Commc’ns Group, Inc.*, 262 F.3d 1258, 1267 (Fed. Cir. 2001). The intrinsic evidence includes the claims themselves, the specification, and the prosecution history. *Phillips*, 415 F.3d at 1314; *C.R. Bard, Inc.*, 388 F.3d at 861. The general rule—subject to certain specific exceptions—is that each claim term is construed according to its ordinary and accustomed meaning as understood by one of ordinary skill in the art at the time of the invention in the context of the patent. *Phillips*, 415 F.3d at 1312–13; *Alloc, Inc. v. Int’l Trade Comm’n*, 342 F.3d 1361, 1368 (Fed. Cir. 2003); *Azure Networks, LLC v. CSR PLC*, 771 F.3d 1336, 1347 (Fed. Cir. 2014) (“There is a heavy presumption that claim terms carry their accustomed meaning in the relevant community at the relevant time.”) (vacated on other grounds).

“The claim construction inquiry ... begins and ends in all cases with the actual words of the claim.” *Renishaw PLC v. Marposs Societa’ per Azioni*, 158 F.3d 1243, 1248 (Fed. Cir. 1998). “[I]n all aspects of claim construction, ‘the name of the game is the claim.’” *Apple Inc. v. Motorola, Inc.*, 757 F.3d 1286, 1298 (Fed. Cir. 2014) (quoting *In re Hiniker Co.*, 150 F.3d 1362, 1369 (Fed. Cir. 1998)). First, a term’s context in the asserted claim can be instructive. *Phillips*, 415 F.3d at 1314. Other asserted or unasserted claims can also aid in determining the claim’s meaning because claim terms are typically used consistently throughout the patent. *Id.* Differences among the claim terms can also assist in understanding a term’s meaning. *Id.* For example, when a dependent claim adds a limitation to an independent claim, it is presumed that the independent claim does not include the limitation. *Id.* at 1314–15.

“[C]laims ‘must be read in view of the specification, of which they are a part.’” *Id.* (quoting *Markman v. Westview Instruments, Inc.*, 52 F.3d 967, 979 (Fed. Cir. 1995) (en banc)). “[T]he

specification ‘is always highly relevant to the claim construction analysis. Usually, it is dispositive; it is the single best guide to the meaning of a disputed term.’” *Id.* (quoting *Vitronics Corp. v. Conceptronic, Inc.*, 90 F.3d 1576, 1582 (Fed. Cir. 1996)); *Teleflex, Inc. v. Ficosa N. Am. Corp.*, 299 F.3d 1313, 1325 (Fed. Cir. 2002). But, “[a]lthough the specification may aid the court in interpreting the meaning of disputed claim language, particular embodiments and examples appearing in the specification will not generally be read into the claims.” *Comark Commc’ns, Inc. v. Harris Corp.*, 156 F.3d 1182, 1187 (Fed. Cir. 1998) (quoting *Constant v. Advanced Micro-Devices, Inc.*, 848 F.2d 1560, 1571 (Fed. Cir. 1988)); *see also Phillips*, 415 F.3d at 1323. “[I]t is improper to read limitations from a preferred embodiment described in the specification—even if it is the only embodiment—into the claims absent a clear indication in the intrinsic record that the patentee intended the claims to be so limited.” *Liebel-Flarsheim Co. v. Medrad, Inc.*, 358 F.3d 898, 913 (Fed. Cir. 2004).

The prosecution history is another tool to supply the proper context for claim construction because, like the specification, the prosecution history provides evidence of how the U.S. Patent and Trademark Office (“PTO”) and the inventor understood the patent. *Phillips*, 415 F.3d at 1317. However, “because the prosecution history represents an ongoing negotiation between the PTO and the applicant, rather than the final product of that negotiation, it often lacks the clarity of the specification and thus is less useful for claim construction purposes.” *Id.* at 1318; *see also Athletic Alternatives, Inc. v. Prince Mfg.*, 73 F.3d 1573, 1580 (Fed. Cir. 1996) (ambiguous prosecution history may be “unhelpful as an interpretive resource”).

Although extrinsic evidence can also be useful, it is “less significant than the intrinsic record in determining the legally operative meaning of claim language.” *Phillips*, 415 F.3d at 1317 (quoting *C.R. Bard, Inc.*, 388 F.3d at 862). Technical dictionaries and treatises may help a court

understand the underlying technology and the manner in which one skilled in the art might use claim terms, but technical dictionaries and treatises may provide definitions that are too broad or may not be indicative of how the term is used in the patent. *Id.* at 1318. Similarly, expert testimony may aid a court in understanding the underlying technology and determining the particular meaning of a term in the pertinent field, but an expert’s conclusory, unsupported assertions as to a term’s definition are not helpful to a court. *Id.* Extrinsic evidence is “less reliable than the patent and its prosecution history in determining how to read claim terms.” *Id.* The Supreme Court has explained the role of extrinsic evidence in claim construction:

In some cases, however, the district court will need to look beyond the patent’s intrinsic evidence and to consult extrinsic evidence in order to understand, for example, the background science or the meaning of a term in the relevant art during the relevant time period. *See, e.g., Seymour v. Osborne*, 11 Wall. 516, 546 (1871) (a patent may be “so interspersed with technical terms and terms of art that the testimony of scientific witnesses is indispensable to a correct understanding of its meaning”). In cases where those subsidiary facts are in dispute, courts will need to make subsidiary factual findings about that extrinsic evidence. These are the “evidentiary underpinnings” of claim construction that we discussed in *Markman*, and this subsidiary factfinding must be reviewed for clear error on appeal.

Teva Pharm. USA, Inc. v. Sandoz, Inc., 135 S. Ct. 831, 841 (2015).

B. Departing from the Ordinary Meaning of a Claim Term

There are “only two exceptions to [the] general rule” that claim terms are construed according to their plain and ordinary meaning: “1) when a patentee sets out a definition and acts as his own lexicographer, or 2) when the patentee disavows the full scope of the claim term either in the specification or during prosecution.”¹ *Golden Bridge Tech., Inc. v. Apple Inc.*, 758 F.3d 1362, 1365 (Fed. Cir. 2014) (quoting *Thorner v. Sony Computer Entm’t Am. LLC*, 669 F.3d 1362, 1365 (Fed.

¹ Some cases have characterized other principles of claim construction as “exceptions” to the general rule, such as the statutory requirement that a means-plus-function term is construed to cover the corresponding structure disclosed in the specification. *See, e.g., CCS Fitness, Inc. v. Brunswick Corp.*, 288 F.3d 1359, 1367 (Fed. Cir. 2002).

Cir. 2012)); *see also GE Lighting Solutions, LLC v. AgiLight, Inc.*, 750 F.3d 1304, 1309 (Fed. Cir. 2014) (“[T]he specification and prosecution history only compel departure from the plain meaning in two instances: lexicography and disavowal.”). The standards for finding lexicography or disavowal are “exacting.” *GE Lighting Solutions*, 750 F.3d at 1309.

To act as his own lexicographer, the patentee must “clearly set forth a definition of the disputed claim term,” and “clearly express an intent to define the term.” *Id.* (quoting *Thorner*, 669 F.3d at 1365); *see also Renishaw*, 158 F.3d at 1249. The patentee’s lexicography must appear “with reasonable clarity, deliberateness, and precision.” *Renishaw*, 158 F.3d at 1249.

To disavow or disclaim the full scope of a claim term, the patentee’s statements in the specification or prosecution history must amount to a “clear and unmistakable” surrender. *Cordis Corp. v. Boston Sci. Corp.*, 561 F.3d 1319, 1329 (Fed. Cir. 2009); *see also Thorner*, 669 F.3d at 1366 (“The patentee may demonstrate intent to deviate from the ordinary and accustomed meaning of a claim term by including in the specification expressions of manifest exclusion or restriction, representing a clear disavowal of claim scope.”). “Where an applicant’s statements are amenable to multiple reasonable interpretations, they cannot be deemed clear and unmistakable.” *3M Innovative Props. Co. v. Tredegar Corp.*, 725 F.3d 1315, 1326 (Fed. Cir. 2013).

C. Definiteness Under 35 U.S.C. § 112, ¶ 2 (pre-AIA) / § 112(b) (AIA)

Patent claims must particularly point out and distinctly claim the subject matter regarded as the invention. 35 U.S.C. § 112, ¶ 2. A claim, when viewed in light of the intrinsic evidence, must “inform those skilled in the art about the scope of the invention with reasonable certainty.” *Nautilus Inc. v. Biosig Instruments, Inc.*, 572 U.S. 898, 910 (2014). If it does not, the claim fails § 112, ¶ 2 and is therefore invalid as indefinite. *Id.* at 901. Whether a claim is indefinite is determined from the perspective of one of ordinary skill in the art as of the time the application for the patent was filed. *Id.* at 911. As it is a challenge to the validity of a patent, the failure of any claim in suit to

comply with § 112 must be shown by clear and convincing evidence. *BASF Corp. v. Johnson Matthey Inc.*, 875 F.3d 1360, 1365 (Fed. Cir. 2017). “[I]ndefiniteness is a question of law and in effect part of claim construction.” *ePlus, Inc. v. Lawson Software, Inc.*, 700 F.3d 509, 517 (Fed. Cir. 2012).

When a term of degree is used in a claim, “the court must determine whether the patent provides some standard for measuring that degree.” *Biosig Instruments, Inc. v. Nautilus, Inc.*, 783 F.3d 1374, 1378 (Fed. Cir. 2015) (quotation marks omitted). Likewise, when a subjective term is used in a claim, “the court must determine whether the patent’s specification supplies some standard for measuring the scope of the [term].” *Datamize, LLC v. Plumtree Software, Inc.*, 417 F.3d 1342, 1351 (Fed. Cir. 2005). The standard “must provide objective boundaries for those of skill in the art.” *Interval Licensing LLC v. AOL, Inc.*, 766 F.3d 1364, 1371 (Fed. Cir. 2014).

III. AGREED CONSTRUCTIONS

The parties have agreed to the following constructions set forth in their Joint Claim Construction Chart Pursuant to Patent Rule 4-5(d). (Dkt. No. 39.)

Term ²	Agreed Construction
“generating B pictures without forward predictions” <ul style="list-style-type: none"> • ’712 Patent Claims 5, 8 	creating B pictures without forward predictions
Preamble of Claims 4, 5, and 8 of the ’712 Patent	preamble is limiting

Having reviewed the intrinsic and extrinsic evidence of record, the Court hereby adopts the parties’ agreed constructions.

² For all term charts in this order, the claims in which the term is found are listed with the term but: (1) only the highest-level claim in each dependency chain is listed, and (2) only asserted claims identified in the parties’ Joint Claim Construction Chart Pursuant to Patent Rule 4-5(d) (Dkt. No. 39) are listed.

IV. CONSTRUCTION OF DISPUTED TERMS

A. “resynchronization marker”

Disputed Term	Plaintiff’s Proposed Construction	Defendants’ Proposed Construction
“resynchronization marker” <ul style="list-style-type: none"> • ’118 Patent Claim 1 	a number of bits in a data stream that cause reconstruction to occur for an excluded macroblock, not including a flag useful only for regions having a motion vector close to zero and for which the texture has not significantly changed	a sequence of bits that can be detected by a receiver when an error occurs in order to start reading the data stream again at that location

The Parties’ Positions

Plaintiff submits: The “resynchronization marker” of the claimed invention is not the “resynchronization marker” of the prior art. Rather, the marker of the invention is defined in the ’118 Patent as a marker in the data stream that indicates that “one or more macroblocks were excluded from the data stream” and that is used to “cause the excluded macroblock(s) to be reconstructed during decoding.” The invented marker is described in the patent as distinct from prior-art markers and flags that “trigger a simple block copy mechanism, which are only useful for regions having a motion vector close to zero and for which the texture has not changed significantly from one image or instance to the next,” such as the MPEG-4 uncoded flags (citing, inter alia, ’118 Patent col.1 ll.20–27, col.1 ll.56–67, col.4 ll.47–65). Defendants’ proposed construction improperly defines the marker as one “that can be detected when an error occurs” when the marker is used in the patent and used in the claims to indicate an “intentional dropping of a macroblock” rather than an error. Further, Defendants’ proposed construction would improperly encompass the “uncoded flags of MPEG-4.” (Dkt. No. 33 at 8–13.)

In addition to the claims themselves, Plaintiff cites the following intrinsic and extrinsic evidence to support its position: **Intrinsic evidence:** '118 Patent col.1 ll.20–27, col.1 ll.56–67, col.2 ll.6–20, col.2 ll.64–67, col.3 ll.1–28, col.3 ll.29–35, col.3 l.37 – col.4 l.15, col.4 ll.47–65, col.7 ll.1–19. **Extrinsic evidence:** Schonfeld Decl.³ ¶¶ 53–56 & n.2 (Plaintiff’s Ex. B, Dkt. No. 33-3).

Defendants respond: The term “resynchronization marker” is used in the '118 Patent according to its plain and ordinary meaning; namely, a “marker (sequence of bits) used to enable resynchronization of the receiver/decoder and data stream when something has gone wrong.” That the patent describes, and the claims otherwise express, that the resynchronization marker is also used for another purpose does not change the meaning of the term. Rather, the purpose of the invention is “*to suggest a coding method [for excluding macroblocks] compatible with coding standards which include point resynchronization means*” (quoting '118 Patent col.2 ll.1–9, emphasis and modification by Defendants). Finally, the MPEG-4 “uncoded flag” is not encompassed by “resynchronization marker” as the “‘uncoded flag’ is not for ‘resynchronization.’” (Dkt. No. 37 at 8–15.)

In addition to the claims themselves, Defendants cite the following intrinsic and extrinsic evidence to support their position: **Intrinsic evidence:** '118 Patent col.1 ll.35–56, col.2 ll.1–10, col.4 ll.47–65. **Extrinsic evidence:** Villasenor Decl.⁴ ¶¶ 49–63 (Defendants’ Ex. A, Dkt. No. 37-1); ISO/IEC, *Information Technology – Coding of Audio-Visual Objects – Part 2: Visual, ISO/IEC 14496-2* at 277 (Dec. 1, 1999) (Defendants’ Ex. B, Dkt. No. 37-2 at 8); Raj Talluri, *Error-Resilient Video Coding in the ISO MPEG-4 Standard*, IEEE Communications Magazine at 113–

³ Declaration of Dr. Dan Schonfeld Regarding US Patent No. 6,895,119, *Uniloc 2017 LLC v. Netflix, Inc.*, 8:18-cv-02055-JVS-DFM (C.D. Cal. Oct. 11, 2019).

⁴ Declaration of John Villasenor, Ph.D.

14 (Defendants’ Ex. C, Dkt. No. 37-3 at 3–4); *The MPEG-4 Book* at 347 (Fernando Pereira & Touradj Ebrahimi eds., 2003) (Defendants’ Ex. D, Dkt. No. 37-4 at 7); Schonfeld Decl. ¶ 48 (Plaintiff’s Ex. B, Dkt. No. 33-3).

Plaintiff replies: The claimed invention does not include any error indication. Rather, the “resynchronization marker” is used in coding and reconstruction of data streams with intentional omission of macroblocks. Defendants would improperly limit “resynchronization” marker to the RESYNC marker of MPEG-4 and exclude other resynchronization markers enumerated in the ’118 Patent, such as “VOPStart,” “GOVStart,” and “EOS” (quoting ’118 Patent col.4 ll.35–41). Finally, the claimed “resynchronization marker” is distinct from the MPEG-4 “uncoded flag” not because of some synchronization use, but because of the nature of the “uncoded flag”; namely, “that is useful only for regions having a motion vector close to zero and for which the texture has not significantly changed.” (Dkt. No. 38 at 4–7.)

Plaintiff cites further intrinsic and extrinsic evidence to support its position: **Intrinsic evidence:** ’118 Patent col.4 ll.35–41. **Extrinsic evidence:** Schonfeld Dep.⁵ at 11:13 – 12:21, 21:6 – 23:10, 24:4–11 (Plaintiff’s Ex. E, Dkt. No. 38-2 at 4–5).

Analysis

The issue in dispute is whether the “resynchronization marker” of the claims should be defined by its ability to enable resynchronization of the system when macroblocks are dropped due to an error condition or by its ability to enable reconstruction of the macroblocks that were intentionally excluded from the data stream. The term “resynchronization marker” is used broadly in the ’118

⁵ Deposition of Dan Schonfeld, Ph.D., *Uniloc 2017 LLC v. Netflix, Inc.*, 8:18-cv-02055-JVS-DFM (C.D. Cal. Oct. 16, 2019).

Patent to denote markers that enable reconstruction of excluded macroblocks for all of I, P, and B coding.

The Court rejects Defendants' proposed construction because its focus on resynchronization on an error condition fails to clarify the claim scope and threatens to inject limitations not supported by the disclosure of the '118 Patent. The Court agrees with Defendants that "resynchronization marker" is used in the '118 Patent to refer to prior-art markers that serve as synchronization points for resynchronizing the decoder with the data stream on an error condition. *See, e.g.*, '118 Patent at col.1 ll.35–56 (describing MPEG-4 resynchronization markers that separate video packets). That said, the patent also suggests a broader use of "resynchronization marker" by describing the "resynchronization marker" placed in the data stream to denote excluded macroblocks:

Depending on the result of the decision step DEC, the macroblock is either inserted into the video packet in a step BC (case N) or excluded from coding in a step EXC (case Y). In step BC, the bits are counted to trigger the insertion of a resynchronization marker in a step MARK when the video packet is of sufficient size. After each step EXC, a resynchronization marker is inserted into the binary data stream in step MARK. Here, the term "synchronization marker" must be interpreted generally to include, for example in the MPEG-4 standard, such conventional markers as RESYNC, VOPStart (start of a temporal instance (plan) of a video object), GOVStart (start of a group of temporal instances of a video object), EOS (end of video session). At the end of the method a binary data stream BIN is thus obtained.

Id. at col.4 ll.28–42.

It is not clear that Defendants' proposed construction covers markers such as VOPStart. For example, some of the references submitted by Defendants suggest that VOPStart is distinct from "resynchronization marker." *See, e.g.*, James Brailean, *Wireless Multimedia Utilizing MPEG-4 Error Resilient Tools* (1999) at 104 ("A resynchronization marker is used to distinguish the start of a new video packet. This marker is distinguishable from all possible VLC codewords as well as the picture, or as it is called in MPEG-4, the Video Object Plane (VOP) start code."), (cited in

Dkt. No. 37-8 at 2); *Signal Recovery Techniques for Image and Video Compression and Transmission* (Aggelos Katsaggelos & Nick Galatsanos eds., 1998) at 163 (same) (cited in Dkt. No. 37-9 at 6). Other references suggest these other markers fall within the genus of “resynchronization marker.” See, e.g., ISO/IEC, *Information Technology — Coding of Audio-Visual Objects — Part 2: Visual, ISO/IEC 14496-2* at 279 (1st ed. 1999) (“When an error is detected in the bitstream, the decoder should resynchronize at the next suitable resynchronization point (vop_start_code or resync_marker).”) (cited in Dkt. No. 37-2 at 10). Further, certain references suggest “resynchronization marker” may be overloaded with both a broad and a specific meaning in the art. See, e.g., *Wireless Multimedia* at 105 (“This approach requires that a second resynchronization marker, the ‘motion marker’ be inserted between motion and texture information.”) (cited in Dkt. No. 37-8 at 3); *ISO/IEC 14496-2* at 278 (describing an error-concealment approach that “requires that a second resynchronization marker be inserted between motion and texture information”) (cited in Dkt. No. 37-2 at 9). In other words, “resynchronization marker” is used in the art to denote both a specific marker (the marker “used to distinguish the start of a new video packet”) and a category of markers (which includes the “motion marker”) while at the same time possibly either encompassing or being distinct from the “VOP start code.” Further, based on the record before the Court, it is not clear that a marker such as the “VOP start code” is used for error recovery, as required by Defendants’ proposed construction of “resynchronization marker.” For example, *Wireless Multimedia* provides that “errors may never be detected until a unique **resynchronization point or start code** is encountered in the bitstream. ... When an error is detected, a video decoder must stop decoding and parse the bitstream for the next **resynchronization point.**” *Wireless Multimedia* at 105 (emphasis added) (cited in Dkt. No. 37-8 at 3). This suggests a distinction between a resynchronization point and a start code and that

error recovery is solely through the resynchronization point. In contrast, *ISO/IEC 14496-2* suggests that the VOP start code may be used for error recovery. *ISO/IEC 14496-2* at 279, Dkt No. 37-2 at 10. In short, the extrinsic evidence suggests that “resynchronization marker” has both a broad and a narrow meaning in the art and Defendants’ proposed construction raises a number of potential scope issues while clarifying little.

In context, the Court understands “resynchronization marker” to have a broad meaning referring to resynchronization capabilities and not necessarily to error conditions. As set forth above, the term appears to be used in the art in both a narrow and broad sense and to be defined by its capability to function as a resynchronization point. The passage at column 4, lines 28 to 42 of the ’118 Patent, while referring to “synchronization marker” rather than “resynchronization marker,” does so solely in the context of describing the placement and use of a “resynchronization marker” in the bit stream. In this context, the Court understands that “resynchronization marker” is used in a broad sense to encompass conventional markers such as RESYNC, VOPStart, GOVStart, and EOS, based on their resynchronization capabilities regardless of error-processing capabilities.

The Court rejects Plaintiff’s proposed construction because the negative limitation excluding flags useful only for regions having a motion vector close to zero and for which the texture has not significantly changed is in some respects too narrow, and because it gives no effect to “resynchronization.” As described above, the patent describes “resynchronization markers” as prior-art markers that may be used to synchronize the decoder and data stream. The patent further provides:

It should be noted that the MPEG-4 standard already proposes not to code certain macroblocks in a video object or, more generally, in a video image, indicating this absence of coding by the presence of an “uncoded” flag. The presence of this flag is interpreted by the decoders which replace the uncoded macroblock with the

macroblock located in the same position in a preceding instance of the video object. In general, the instance immediately preceding the instance in question is used. As a consequence, this flag can only be used for P coded images, for which a preceding instance is available and implicitly echoed in B coded images. The insertion of a flag of this nature is therefore only useful for regions having a motion vector close to zero and for which the texture has not changed significantly from one image or instance to the next. The exclusion of macroblocks from coding according to the invention does not entail the insertion of any specific flag and the exclusion of macroblocks from coding is thus possible for all modes of I, P or B coding.

'118 Patent col.4 ll.47–65. This explains that the “resynchronization marker” of the patent does not encompass a “flag [that] can only be used for P coded images” but rather encompasses only markers that can be used “for all modes of I, P or B coding.” Given the juxtaposition of “only ... P coded images” with “all modes of I, P or B coding,” Plaintiff’s argument that “all modes of I, P or B coding” effectively means that a “resynchronization marker” must merely be able to handle all modes of one coding type (e.g., only P coding) is not persuasive. (*See, e.g.*, Dkt. No. 38 at 8.)

Ultimately, the Court rejects both Plaintiff’s and Defendants’ proposed constructions as failing to capture the meaning of “resynchronization marker” in the '118 Patent. As the Court “has an independent obligation to determine the meaning of the claims, notwithstanding the views asserted by the adversary parties,” *Exxon Chem. Patents, Inc. v. Lubrizol Corp.*, 64 F.3d 1553, 1555 (Fed. Cir. 1995), the Court is left to craft a construction based on the record before it. The “resynchronization marker” of the '118 Patent: (1) is able to serve as a resynchronization point, *see, e.g.*, '118 Patent col.1 ll.35–56; (2) is able to serve as an excluded-macroblock-reconstruction trigger in I, P, and B coding, *see, e.g., id.* at col.4 47–65, col.6 l.62 – col.7 l.29; (3) encompasses such markers as VOPStart, *see, e.g., id.* at col.4 ll.28–42; and (4) triggers macroblock reconstruction via an error-concealment method, *see, e.g., col.8 ll.4–5 (Claim 1); see also, id.* at [57] Abstract. The proper construction of “resynchronization marker” should capture all these aspects. *See Phillips v. AWH Corp.*, 415 F.3d 1303, 1316 (Fed. Cir. 2005) (en banc) (“The construction that stays true to the claim language and most naturally aligns with the patent’s

description of the invention will be, in the end, the correct construction.” (quotation marks omitted)); *Trs. of Columbia Univ. v. Symantec Corp.*, 811 F.3d 1359, 1363 (Fed. Cir. 2016) (“The only meaning that matters in claim construction is the meaning in the context of the patent.”).

Accordingly, the Court construes “resynchronization marker” as follows:

- “resynchronization marker” means “sequence of bits in a data stream that can serve as a resynchronization point and an error-concealment-reconstruction point of excluded macroblock(s) for all modes of coding.”

B. “digital image”

Disputed Term	Plaintiff’s Proposed Construction	Defendants’ Proposed Construction
“digital image” • ’118 Patent Claim 1	plain meaning	the coding must be capable of excluding macroblocks for I, B, and P coded “digital images”

The Parties’ Positions

Plaintiff submits: The term “digital image” is used in its ordinary, broad, sense in the claims and therefore does not require each of I, B, and P coded images.⁶ Claim 1 is for coding a “digital image,” not necessarily for coding the packet of three separate images or for coding already coded images, as proposed by Defendants. Further, it would be improper to interpret “digital image” as limited to I, B, or P coded images based on the ’118 Patent’s disclosure of exemplary embodiments of coded digital images that include I, B, an P codes images. (Dkt. No. 33 at 13–14.)

Defendants respond: As described in the ’118 Patent, the important feature of “the invention” is that it enables exclusion of macroblocks within a video stream that applies to all of I, B, and P

⁶ Defendants originally proposed construing “digital image” as “I, B, and P coded images.” (Dkt. No. 33 at 13; *see also*, Exhibit A to Joint Claim Construction and Prehearing Statement at 1, Dkt. No. 32-1 at 2.)

image types. This is described as an improvement over the prior art in that the prior art was limited to handling exclusion of only P images (citing '118 Patent col.4 ll.50–65). (Dkt. No. 37 at 15–21.)

In addition to the claims themselves, Defendants cite the following intrinsic and extrinsic evidence to support their position: **Intrinsic evidence:** '118 Patent col.4 ll.47–65, col.7 ll.41–47. **Extrinsic evidence:** Villasenor Decl. ¶¶ 31, 35, 65–73 (Defendants' Ex. A, Dkt. No. 37-1).

Plaintiff replies: There is no disavowal or lexicography that justifies limiting the meaning of “digital image” that is to be coded to require all of I, P, and B coded images.⁷ Rather, the '118 Patent provides that the invention is applicable to “*all modes* of I coding, *or all modes* of P coding, *or all modes* of B coding” (Plaintiff's emphasis). (Dkt. No. 38 at 7–9.)

Plaintiff cites further **intrinsic evidence** to support its position: '118 Patent col.4 ll.61–65, col.7 ll.41–47.

Analysis

The issue in dispute distills to whether the method of Claim 1 necessarily is capable of coding in all of I, P, and B coding. It is, though the claim does not require all modes of coding. This aspect of the claimed invention is set forth in the construction of “resynchronization marker,” as described above, and is not properly an aspect of “digital image.”

The term “digital image” is used in the '118 Patent according to its plain meaning and a given digital image does not necessarily include all of I, P, and B coded images. While the Court understands that Defendants are not advocating that a “digital image” necessarily includes each of I, P, and B coded images, their proposed construction threatens such an application. As such, the

⁷ Plaintiff represents and addresses Defendants' proposed construction as “I, B, and P coded images.” (Dkt. No. 38 at 7.) In their responsive brief, Defendants represented their proposed construction as “the coding must be capable of excluding macroblocks for I, B, and P coded “digital images.”” (Dkt. No. 37 at 15.)

Court rejects Defendants’ proposed construction as potentially confusing even while it agrees that the method of Claim 1 necessarily is capable of any of I, P, and B coding by virtue of the resynchronization marker.

Accordingly, the Court determines that “digital image” has its plain and ordinary meaning without the need for further construction.

C. Preamble of Claim 1 of the ’118 Patent

Disputed Term	Plaintiff’s Proposed Construction	Defendants’ Proposed Construction
“A method of coding a digital image comprising macroblocks in a binary data stream, the method comprising:” <ul style="list-style-type: none"> • ’118 Patent Claim 1 	plain meaning	preamble is limiting

The Parties’ Positions

Plaintiff submits: The “preamble [of Claim 1] only states a purpose or intended use for the invention (i.e., a method of coding a ‘digital image’), it is not an affirmative structural limitation of claim 1.” (Dkt. No. 33 at 15–16.)

In addition to the claims themselves, Plaintiff cites the following **intrinsic evidence** to support its position: ’118 Patent col.4 ll.61–64, col.7 ll.41–47.

Defendants respond: The preamble is limiting because it defines the claimed invention. The preamble recites what is to be coded (the “digital image”) and provides the antecedent bases for “macroblocks” and “binary data stream” recited in the body of the claim. Thus, the preamble provides structure and context necessary to properly understand the claim. The ’118 Patent further sets forth “the invention” as a “method of coding a digital image comprising macroblocks in a binary data stream” which is clearly found only in the preamble. Thus, the preamble provides an

important aspect of the invention not captured solely in the body of the claim. (Dkt. No. 37 at 21–24.)

In addition to the claims themselves, Defendants cite the following **intrinsic evidence** to support their position: ’118 Patent, at [54] Title, [57] Abstract, col.2 ll.13–15, col.2 ll.54–57, col.4 l.66 – col.5 l.1

Plaintiff replies: The term “digital image” in the preamble does not appear elsewhere in the claim and thus is not an essential structure or fundamental characteristic of the claimed invention. It is not limiting. (Dkt. No. 38 at 9–10.)

Analysis

The issue in dispute is whether the preamble merely states an intended use and is therefore not limiting or whether it is essential to a proper understanding of Claim 1 of the ’118 Patent and is therefore limiting. The preamble is essential to properly understanding the claim and is limiting.

The preamble of Claim 1 is limiting in its entirety. Under Federal Circuit precedent “a preamble is not limiting where a patentee defines a structurally complete invention in the claim body and uses the preamble only to state a purpose or intended use for the invention.” *Acceleration Bay, LLC v. Activision Blizzard, Inc.*, 908 F.3d 765, 770 (Fed. Cir. 2018) (quotation marks and citations omitted). A preamble is limiting, however, when it “necessary to give life, meaning, and vitality to the claim.” *Catalina Mktg. Int’l v. Coolsavings.com, Inc.*, 289 F.3d 801, 808 (Fed. Cir. 2002) (quotation marks omitted). For example, “dependence on a particular disputed preamble phrase for antecedent basis may limit claim scope because it indicates a reliance on both the preamble and claim body to define the claimed invention.” *Id.* “Likewise, when the preamble is essential to understand limitations or terms in the claim body, the preamble limits claim scope.” *Id.* “Further, when reciting additional structure or steps underscored as important by the

specification, the preamble may operate as a claim limitation.” *Id.* Here, the preamble provides more than simply a statement of intended use, it reflects important aspects of the described invention and is essential to properly understanding limitations in the claim body.

A preamble is limiting when it tethers the claim body to the described invention. For example, in *Corning Glass Works v. Sumitomo Elec. U.S.A., Inc.*, the Federal Circuit noted that the “specification makes clear that the inventors were working on the particular problem of an effective optical communication system not on general improvements in conventional optical fibers” and held the “optical waveguide” language in the preamble was limiting when the claim body was ostensibly directed to optical fibers irrespective of any waveguide properties. 868 F.2d 1251, 1256–57 (Fed. Cir. 1989). In other words, the claim body was properly understood only with reference to the preamble and the preamble was thus limiting. *Id.* Similarly, in *GE Co. v. Nintendo Co., LTD.*, the Federal Circuit noted that “the ’125 specification makes clear that the inventors were working on the particular problem of displaying binary data on a raster scan display device and not general improvements to all display systems” and held “system for displaying a pattern on a raster scanned display device” in the preamble as limiting when the claim body was ostensibly directed to all types of display systems. 179 F.3d 1350, 1361–62 (Fed. Cir. 1999). The Federal Circuit addressed a similar issue in *Applied Materials, Inc. v. Advanced Semiconductor Materials Am., Inc.*, 98 F.3d 1563 (Fed. Cir. 1996). There, it noted that the “specification also states that the purpose of the invention” was to address a problem in a “cold purge process” and held “[i]n a cold purge process” in the preamble as limiting. *Id.* at 1571–73. *See also, Poly-America, L.P. v. GSE Lining Tech., Inc.*, 383 F.3d 1303, 1309–10 (Fed. Cir. 2004) (reading the preamble as limiting because the patent document “shows that the inventor considered that the ... preamble language represented an important characteristic of the claimed invention”); *On Demand Mach. Corp. v.*

Ingram Indus., 442 F.3d 1331, 1343–44 (Fed. Cir. 2006) (reading the preamble as limiting because “it states the framework of the invention ... [that] is fundamental to the [] invention” as described in the patent and therefore “embraces the totality of [the recited] limitations, and limits the claim to the subject matter of the preamble”); *Mems Tech. Berhad v. ITC*, 447 F. App’x 142, 153–54 (Fed. Cir. 2011) (reading the preamble as limiting because it states “the essence of the invention” and “standing alone, the bodies of [the claims] do not require” the important characteristic of the invention recited in the preamble). Common to these cases is that the preamble is limiting when the preamble tethers the claim to the focus of the described invention—when it provides an important aspect of the invention and that aspect is not understood solely from body of the claim.

The preamble of Claim 1 provides essential context to properly understand the body of the claim. To begin, it provides the antecedent basis for “the binary data stream” of the claim body and recites characteristics of that stream that are not apparent solely from the body of the claim; namely, the stream comprises the macroblocks that are constituents of a digital image. The preamble expressly clarifies that the macroblocks of the body of the claim are in the binary data stream while the body of the claim does not express this, though it supports such an inference. For example, the only suggestion in the body of the claim that the macroblocks are in the binary data stream is found in the last clause: “inserting a resynchronization marker into the binary data stream after the exclusion of one or more macroblocks.” ’118 Patent col.8 ll.10–12. Absent the preamble’s recitation of “macroblocks in a binary data stream,” it is possible to imagine the macroblocks as independent of the binary data stream, perhaps in some other stream. The preamble’s “method of coding” also provides antecedent context for understanding the body’s “decision step for macroblocks to be excluded from the coding.” Finally, the preamble is the only reference to “digital image” in the claim, and the digital image is an important feature of the invention. *See*,

e.g., ’118 Patent at [54] Title (“Method of Coding Digital Image”), [57] Abstract (“The invention relates to a method of coding a digital image.”), col.1 ll.6–7, col.2 ll.43–53 (describing all the figures as related to “digital image” or “video”), col.2 ll.54–59 (“a method of coding a digital image ... according to the invention”). Absent the context of “digital image” in the preamble, it is possible to imagine Claim 1 encompassing data coding in the abstract rather than being specifically directed as described in the patent, to coding digital images. Thus, the preamble plays a necessary role in properly understanding the claim and is therefore limiting.

Accordingly, the Court holds that the preamble of Claim 1 of the ’118 Patent is limiting in its entirety.

D. “switch request”

Disputed Term	Plaintiff’s Proposed Construction	Defendants’ Proposed Construction
“switch request” <ul style="list-style-type: none"> • ’172 Patent Claims 4, 5, 8 	plain meaning, alternatively: <ul style="list-style-type: none"> • request to switch 	request to switch buffered inputs

The Parties’ Positions

Plaintiff submits: Defendants’ proposed construction would exclude both exemplary embodiments described in the ’172 Patent. The first embodiment (depicted in Figures 2 through 4) is directed to switching between the outputs of two buffers, not the inputs. The second embodiment (depicted in Figures 5 through 7) is directed to switching between the outputs of a decoding process, not of buffers. (Dkt. No. 33 at 17–19.)

In addition to the claims themselves, Plaintiff cites the following **intrinsic evidence** to support its position: ’712 Patent figs.2–7, col.3 ll.62–66, col.4 ll.26–29, col.5 ll.48–57, col.6 ll.1–3.

Defendants respond: The description and the claims of the ’712 Patent require that the input streams, which are the object of the switch request, are buffered. Thus, the claimed “switch, at a

switch request, from the first input stream to the second input stream” is a switch between buffered inputs. This does not preclude “additional processing of the data streams after they enter the buffer.” (Dkt. No. 37 at 26–28.)

In addition to the claims themselves, Defendants cite the following **intrinsic evidence** to support their position: ’712 Patent figs.1–7, col.3 ll.7–13, col.3 ll.33–44, col.5 ll.27–32.

Plaintiff replies: In the embodiment depicted in Figure 5, “the input streams are no longer being buffered when they are switched and limiting the request to switch to ‘buffered inputs’ is incorrect.” (Dkt. No. 38 at 10.)

Analysis

The issue in dispute appears to be whether the streams that are switched “at a switch request” are necessarily buffered streams. This is not a function of “switch request” nor is it the term’s defining feature. In the claims, whether the switch request necessarily requests a switch between streams that are buffered is irrelevant, so long as the switch between streams occurs by controlling the storage of the streams during the buffering step.

Claims 4, 5, and 8 of the ’712 Patent each specify that the “switch request” is linked to “controlling the storage of the [first and second] input streams during the buffering step to switch ... from the first input stream to the second input stream.” The buffering step is the step “in which data contained in the first and the second input stream are stored.” The claims further recite “transcoding the stream provided by the control step.” From this, the Court understands the claims specify switching between streams by controlling storage of the streams during the buffering step. The claims do not, however, express that the switch must be between buffered streams.

The parties dispute whether the embodiment of Figure 5 discloses switching between buffered inputs and, therefore, whether this embodiment would be excluded under Defendants' proposed construction. Figure 5, reproduced below, includes two input streams (IS1, IS2) that flow into a buffer system (BUF1, BUF2) and then out of the buffers to a switch (COM2) through transcoding blocks (VLD1, DQ1, VLD2, DQ2) then through the switch out to other transcoding blocks (Q, VLC, BUF, REG). The Figure 5 switch (COM2) controls and selects the flow out of the buffers. The buffers are each "at least M pictures long." Switching from IS1 to IS2 with COM2 ultimately results in "the reading pointer of the second buffer being positioned at the beginning of the second set of M pictures."⁸ See '712 Patent col.5 l.26 – col.6 l.34. In this sense, the switch occurs between the buffered input streams. The outputs of the DQ1 and DQ2 transcoding blocks, which are the inputs to the COM2 switch are, however, not described or depicted as necessarily buffered.

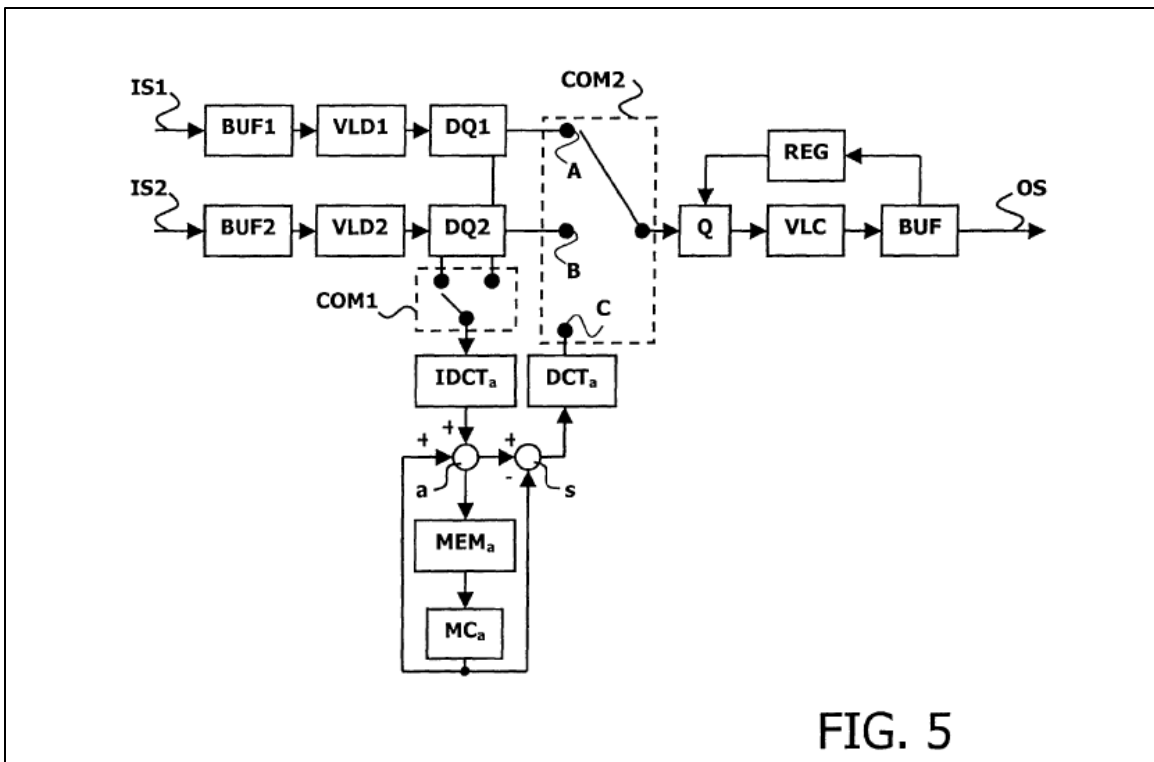

FIG. 5

⁸ Figure 5 further includes another switch (COM1) connecting to a decoder (IDCTa, MEMa, MCa) for the purpose of generating B pictures without forward predictions from buffered input streams. '712 Patent col.6 ll.4–19.

The Court is not persuaded that Defendants’ proposed construction properly clarifies claim scope. Instead, it threatens to inject ambiguity or improper limitations. Ultimately, whether a particular accused or prior-art system satisfies the “switch request” limitation is an issue of fact, wherein the fact-finder must determine, *inter alia*, whether the switch is effected by controlling storage of the input streams during the buffering process, as plainly stated in the claims.

Accordingly, the Court rejects Defendants’ proposed construction and determines the “switch request” has its plain and ordinary meaning without the need for further construction.

E. “the buffering step being controlled to transmit an I picture”

Disputed Term	Plaintiff’s Proposed Construction	Defendants’ Proposed Construction
“the buffering step being controlled to transmit an I picture” • ’172 Patent Claim 5	plain meaning	indefinite

The Parties’ Positions

Plaintiff submits: The meaning of this term is reasonably certain in the context of the ’172 Patent: what constitutes an “I picture” is well known to those of skill in the art and various ways of controlling the buffering step to transmit an I picture is described in the patent. (Dkt. No. 33 at 20–22.)

In addition to the claims themselves, Plaintiff cites the following intrinsic and extrinsic evidence to support its position: **Intrinsic evidence:** ’712 Patent figs.1, 5, col.1 l.38 – col.2 l.36, col.2 l.66 – col.3 l.6, col.3 l.15, col.3 ll.62–66, col.4 ll.3–10, col.6 ll.4–14. **Extrinsic evidence:** Richardson Decl.⁹ ¶¶ 31, 33–36 (Plaintiff’s Ex. D, Dkt. No. 33-5).

⁹ Declaration of Dr. Iain Richardson in Support of Plaintiff’s Opening Claim Construction Brief for U.S. Patent No. 6,628,712.

Defendants respond: The “buffering step” is described in the ’712 Patent and recited in the claim for “storing,” and a “*storing* step cannot be controlled to *transmit*” (Defendants’ emphasis). “Storage and transmission are distinct functions” and Claim 5 is therefore nonsensical—and indefinite. Contrary to Plaintiff’s characterization of the patent’s descriptions of transmitting an I picture, the cited material describes the switching, not the buffering, controlling the transmission. (Dkt. No. 37 at 30–32.)

In addition to the claims themselves, Defendants cite the following intrinsic and extrinsic evidence to support their position: **Intrinsic evidence:** ’712 Patent, at [57] Abstract, col.1 ll.43–46, col.1 ll.62–64, col.4 ll.3–10, col.6 ll.4–14. **Extrinsic evidence:** Villasenor Decl. ¶¶ 75, 78–83 (Defendants’ Ex. A, Dkt. No. 37-1).

Plaintiff replies: Defendants’ indefiniteness position is based on expert testimony that contradicts the clear teaching of the ’712 Patent. For example, the patent describes a scenario with the “second buffer being ready to transmit an I picture” (quoting ’712 Patent col.3 ll.62–66). (Dkt. No. 38 at 11.)

Analysis

The issue in dispute distills to whether—in the art—buffering can be controlled to effect transmission. The Court does not perceive this as an issue of indefiniteness under 35 U.S.C. § 112, ¶ 2. Indeed, the meaning of the claim language is not ambiguous. Further, the Court agrees with Plaintiff that the ’712 Patent includes multiple descriptions of buffers transmitting pictures. *See, e.g.*, ’712 Patent col.2 ll.1–2 (“first buffer has transmitted a set of M pictures of the first input stream”), col.2 ll.22–23 (“the first buffer has transmitted a set of M pictures of the first input stream”), col.3 ll.64–66 (“when said first buffer has transmitted a set of M pictures, said second

buffer being ready to transmit an I picture”). In fact, every figure depicts buffers with data received in on one side and transmitted out the other.

Accordingly, the Court holds that Defendants have not met their burden to prove any claim is indefinite for reason of including “the buffering step being controlled to transmit an I picture.”

V. CONCLUSION

The Court adopts the constructions set forth above, as summarized in the following table:

Section	Term	Construction
A	“resynchronization marker” <ul style="list-style-type: none"> • ’118 Patent Claim 1 	sequence of bits in a data stream that can serve as a resynchronization point and an error-concealment-reconstruction point of excluded macroblock(s) for all modes of coding
B	“digital image” <ul style="list-style-type: none"> • ’118 Patent Claim 1 	plain and ordinary meaning
C	“A method of coding a digital image comprising macroblocks in a binary data stream, the method comprising:” <ul style="list-style-type: none"> • ’118 Patent Claim 1 	limiting
D	“switch request” <ul style="list-style-type: none"> • ’172 Patent Claims 4, 5, 8 	plain and ordinary meaning
E	“the buffering step being controlled to transmit an I picture” <ul style="list-style-type: none"> • ’172 Patent Claim 5 	plain and ordinary meaning
AGREED	“generating B pictures without forward predictions” <ul style="list-style-type: none"> • ’712 Patent Claims 5, 8 	creating B pictures without forward predictions
	Preambles of Claims 4, 5, and 8 of the ’712 Patent	preamble is limiting

The parties are **ORDERED** that they may not refer, directly or indirectly, to each other's claim-construction positions in the presence of the jury. Likewise, the parties are **ORDERED** to refrain from mentioning any portion of this opinion, other than the actual definitions adopted by the Court, in the presence of the jury. Any reference to claim-construction proceedings is limited to informing the jury of the definitions adopted by the Court.

By the date set forth in the Docket Control Order, the parties are hereby **ORDERED**, in good faith, to mediate this case with the designated mediator. As a part of such mediation, each party shall appear by counsel (with lead and local counsel present and participating) and by at least one corporate officer possessing sufficient authority and control to unilaterally make binding decisions for the corporation adequate to address any good faith offer or counteroffer of settlement that might arise during such mediation. Failure to do so shall be deemed by the Court as a failure to mediate in good faith and may subject that party to such sanctions as the Court deems appropriate.

So ORDERED and SIGNED this 17th day of February, 2020.



RODNEY GILSTRAP
UNITED STATES DISTRICT JUDGE