

NOTE: This disposition is nonprecedential.

United States Court of Appeals for the Federal Circuit

2007-1523

FARGO ELECTRONICS INC.,

Plaintiff-Appellant,

v.

IRIS, LTD., INC.,

Defendant-Appellee.

David P. Swenson, Robins, Kaplan, Miller & Ciresi, L.L.P., of Minneapolis, Minnesota, argued for plaintiff-appellant. With him on the brief were Robert J. Gilbertson and Sang Young A. Brodie.

J. Derek Vandenburg, Carlson, Caspers, Vandenburg & Lindquist, P.A., of Minneapolis, Minnesota, argued for defendant-appellee. With him on the brief were Brian W. Hayes and Rachel C. Hughey.

Appealed from: United States District Court for the District of Minnesota

Judge John R. Tunheim

NOTE: This disposition is nonprecedential.

United States Court of Appeals for the Federal Circuit

2007-1523

FARGO ELECTRONICS INC.,

Plaintiff-Appellant,

v.

IRIS, LTD., INC.,

Defendant-Appellee.

Appeal from the United States District Court for the District of Minnesota in case no. 04-1017, Judge John R. Tunheim.

DECIDED: June 27, 2008

Before NEWMAN, PROST, and MOORE, Circuit Judges.

PROST, Circuit Judge.

Fargo Electronics, Inc. (“Fargo”) appeals a decision of the United States District Court for the District of Minnesota granting partial summary judgment of no contributory or induced infringement of claims 1 through 7 of U.S. Patent No. 5,755,519 (the “’519 Patent”), and invalidity of claims 8 through 15 of the ’519 Patent. Fargo Elecs., Inc. v. Iris Ltd., Inc., No. 04-1017, 2005 U.S. Dist. LEXIS 34493, *15-16, *23 (D. Minn. Nov. 30, 2005) (“Summary Judgment Order”). We affirm.

BACKGROUND

Fargo manufactures and sells photo identification (“ID”) card printers and replacement ink ribbons. Fargo makes a number of different types of ribbons, with

different characteristics, for use in its photo ID card printers. Fargo's printers have a sensor, which identifies the ribbon type by detecting identifying indicia arranged in the ribbon supply roll.

Fargo owns two patents, the '519 Patent and U.S. Patent No. 6,152,625 (the "625 Patent"), relating to printer ribbon supply rolls with identifying indicia and sensors to detect the indicia during operation of a printer. Figure 7 of the '519 Patent shows a schematic view of a printer ribbon supply roll 54, including a magnetic sensor core 58 with a plurality of apertures or bores arranged around the periphery, and a Hall Effect sensor 42 attached to the printer to detect pins in the apertures or bores as they pass the sensor.

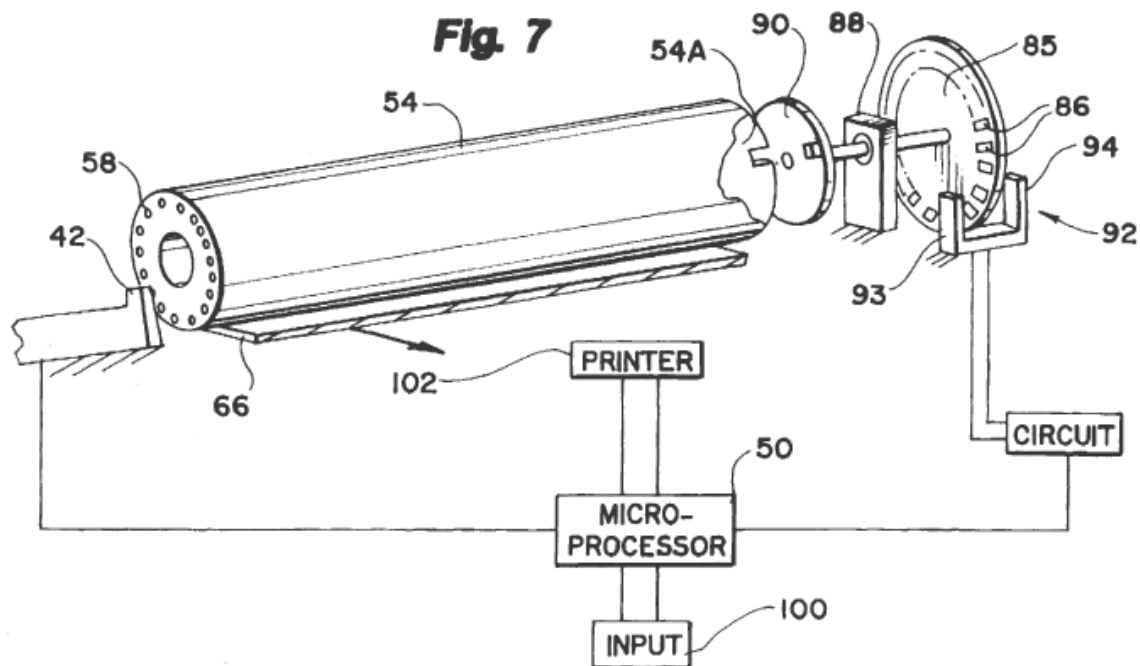

'519 Patent col.4 ll.65-67, col.5 ll.10-19, 64-67.

IRIS, Ltd., Inc. (“IRIS”), a former Fargo distributor, makes and sells replacement ribbons with identifying indicia compatible with Fargo printers. Upon learning of the IRIS replacement ribbons, Fargo terminated IRIS’s distribution agreement and filed suit in the United States District Court for the District of Minnesota alleging, inter alia, infringement of the ’519 and ’625 Patents.

In June 2004, Fargo moved for a preliminary injunction to prevent IRIS from selling its ribbon called Ribbon Choices No. 81733G (“81733G ribbon”). In March 2005, pursuant to IRIS’s stipulation that it would not make, use, sell, or offer to sell the 81733G ribbon, the district court granted in part Fargo’s preliminary injunction motion and enjoined the sale of the 81733G ribbon. Fargo alleges that after the preliminary injunction hearing, IRIS began making and selling another ribbon (the “FPYMCKO-250 ribbon”), which is also compatible with Fargo’s printers. In June 2005, Fargo filed its Second Amended Complaint including the FPYMCKO-250 ribbon in this suit.

Thereafter, the district court construed the disputed claim terms and granted partial summary judgment in favor of IRIS. Summary Judgment Order, at *15-16, *23. The court concluded that claims 8 through 15 of the ’519 Patent are invalid as indefinite under 35 U.S.C. § 112, ¶ 2. Id. at *15-16. The court also concluded that claims 1 through 7 of the ’519 Patent are not infringed contributorily or by inducement because the reasonable repair doctrine applies such that there is not an underlying act of direct infringement. Id. at *23. The parties later agreed to dismiss the remaining counts with prejudice, and the court entered final judgment. This appeal followed. We have jurisdiction over this appeal pursuant to 28 U.S.C. § 1295(a)(1).

DISCUSSION

A. Standard of Review

We review a district court's grant of summary judgment without deference, drawing all reasonable inferences in favor of the nonmovant. Perricone v. Medicis Pharm. Corp., 432 F.3d 1368, 1372 (Fed. Cir. 2005). We review a district court's claim construction as a matter of law without deference, including a determination that a claim is indefinite under 35 U.S.C. § 112, ¶ 2. See Novo Indus., L.P. v. Micro Molds Corp., 350 F.3d 1348, 1353 (Fed. Cir. 2003).

B. Indefiniteness

As previously noted, the district court determined that independent claim 8 of the '519 Patent is invalid as indefinite under 35 U.S.C. § 112, ¶ 2. Summary Judgment Order, at *15-16. Claim 8 recites:

An ink ribbon supply roll comprising a roll core, a plurality of supports comprising a first support and a plurality of second supports formed in a member movable with the roll core and radially spaced from an axis of rotation of the roll core when the roll core rotates as ribbon thereon is removed, and first identifier indicia comprising an unmagnetized magnetic material in a first support to indicate a home position, the second supports other than the being oriented at known positions relative to the home position and at least one second support carrying a removable unmagnetized magnetic material identifier indicia.

'519 Patent col.7 l.46–col.8 l.9 (emphasis added).

Fargo argued to the district court that claim 8 does not have an error and that it should be construed according to standard principles of claim construction. Fargo submitted the following two proposed “constructions” of the limitation “the second supports other than the” to the district court:

- (1) “the supports other than the first support” (thus deleting “second” and adding “first support”); or

(2) “the second supports” (thus deleting “other than the”).

Summary Judgment Order, at *9. The district court concluded that claim 8 contains an error, and that both of the proposed “constructions” require the addition or subtraction of claim terms. Id. Thus, the district court determined that correction of the claim would require the application of principles of claim correction as explained by this court in Novo Industries, rather than standard principles of claim construction. It noted that in Novo Industries this court held that a district court may only correct an error in a patent by interpretation of the patent “if (1) the correction is not subject to reasonable debate based on consideration of the claim language and the specification and (2) the prosecution history does not suggest a different interpretation of the claims.” 350 F.3d at 1354. After considering the parties’ arguments and proposed constructions, the district court determined that it “would have to engage in conjecture” in order to assign a meaning to the phrase “second supports other than the.” Summary Judgment Order, at *15. It concluded that it could not correct claim 8 under Novo Industries and, accordingly, that independent claim 8 is invalid as indefinite. Because dependent claims 9 through 15 depend from claim 8, the district court found that they are also invalid as indefinite.

Fargo makes two main arguments on appeal regarding indefiniteness. First, it argues that claim 8 does not contain a mistake and the district court should have construed it according to standard principles of claim construction, rather than engaging in a claim correction analysis under Novo Industries. Second, it argues in the alternative that if there is an error in claim 8, it is correctable under Novo Industries. We address each argument in turn.

A plain reading of claim 8 shows that there is an error. We reject Fargo's argument to the contrary. As the district court noted, "the phrase 'second supports other than the' naturally leads the reader to expect a description of a further subset of that category of supports known as 'second supports.'" Summary Judgment Order, at *13. Claim 8 as issued, however, does not identify the object of the phrase "other than the." Absent correction, "[t]he claim is invalid for indefiniteness because it is 'insolubly ambiguous' and not 'amenable to construction.'" Novo Indus., 350 F.3d at 1358 (quoting Exxon Research & Eng'g Co. v. United States, 265 F.3d 1371, 1375 (Fed. Cir. 2001)). Thus, the district court did not err by engaging in a claim correction analysis under Novo Industries.

Accordingly, we next turn to the question of whether the district court properly determined that it could not correct the error in claim 8 under Novo Industries. In this regard, on appeal Fargo submits that the claim limitation "the second supports other than the being oriented at known positions relative to the home position" should be construed to mean "the apertures or bores not in the home position are located in predetermined positions having reference to the home position." Appellant's Br. 10. Responding to this proposed construction as well as the two constructions that Fargo proposed to the district court, IRIS argues that "[h]aving offered these three possible corrections, Fargo cannot dispute that each one constitutes a reasonable correction of the error in claim 8." Appellee's Br. 22. It further argues that "each of these three corrections results in a claim of different scope." Id. Fargo disagrees, claiming that "[i]n the present case, unlike Novo, the plausible proposed corrections would lead to the same scope for claim 8 as simply performing a claim construction analysis." Appellant's

Reply Br. 6. Thus, while the parties do not appear to dispute that there are multiple reasonable ways to correct the error in claim 8 (in fact Fargo itself has proposed several possible corrections), they disagree as to whether there is a reasonable debate as to the proper correction and whether all of the reasonable corrections would result in the same claim scope.

With regards to the question of claim scope, Fargo appears to argue that claim 8 should be construed to require two pins in two supports to indicate the home position and at least one other pin in a support located at a known position relative to the home position. For example, in discussing the construction that it proposes on appeal—“the apertures or bores not in the home position are located in predetermined positions having reference to the home position”—Fargo submits that

[t]he full limitation at issue could be described even more simply by stating merely that it requires at least one pin in a second support at a known location apart from the home position. When one of ordinary skill reads the entire '519 patent, the only way to identify a specific printer ribbon in this novel scheme relies on two pins in a home position, plus at least one pin in another known position.

Appellant's Reply Br. 4-5.

At least one of the other constructions proposed by Fargo, however, would appear to require only one support in the home position and at least two supports located at known positions relative to the home position. Specifically, under Fargo's proposed construction to the district court—“the supports other than the first support being oriented at known positions relative to the home position”—it appears that a singular “first support” indicates the home position, while all other “supports” must be oriented at known positions relative to the home position. IRIS also points to the following statement in the specification as an example that it claims does not require

two supports in the home position: “While binary codes could be used, more magnets are required.” ’519 Patent col.2 ll.41-42. It argues that, while a “binary code” arrangement may not be the preferred embodiment because it would require more magnets, it is an example in the specification where two pins would not be required in the home position. See Oral Arg. at 36:38, available at <http://www.cafc.uscourts.gov/oralarguments/mp3/2007-1523.mp3>. Additionally, we note that the constructions requiring only one “first support” in the home position seem consistent with the broad language used multiple times in claim 8 when the patentee refers to a singular “first support.” See ’519 Patent col.7 l.46–col.8 l.6 (“a plurality of supports comprising a first support and a plurality of second supports . . . , and first identifier indicia comprising an unmagnetized magnetic material in a first support to indicate a home position” (emphases added)).

Further, IRIS proposes the following correction for the disputed limitation in claim 8: “the second supports other than the one adjacent the first support being oriented at known positions relative to the home position.” Appellee’s Br. 24. This correction would include one of the “second supports” in the home position (in addition to a singular “first support”). As the district court noted,

[t]he language of claim 8 . . . refers to “first identifier indicia . . . in a first support,” with “support” being singular, yet the specification shows more than one support in the “home position.” Thus, it appears possible that “the second supports other than the” could refer to the other support in the “home position,” which is a correction inconsistent with that proposed by Fargo.

Summary Judgment Order, at *13. This approach appears consistent with Fargo’s argument on appeal that the claim requires two pins and two supports in the home position and at least one other pin in a support located at a known position relative to

the home position. It is inconsistent, however, with other Fargo arguments on appeal, including its argument that a second support cannot be one of the supports in the home position. See Appellant's Br. 16 (stating that "the 'second supports' elements are not in the 'home position'"); Appellant's Reply Br. 9 n.14 ("The second supports element does not—and cannot—define the home position, and must be elsewhere.").

Moreover, we agree with the district court that "the phrase 'second supports other than the' naturally leads the reader to expect a description of a further subset of that category of supports known as 'second supports.' Fargo's proposed constructions take any such additional differentiation out of the phrase completely." Summary Judgment Order, at *13-14. Based on our review of the record and the arguments presented by the parties, we conclude that the specification and claims do not resolve the reasonable debate as to the proper way to correct the obvious error in claim 8.

Finally, while it is not entirely clear if it intends this argument to apply in the correction context, we note that Fargo argues that the prosecution history supports only one reasonable construction of claim 8. IRIS maintains, however, that under Novo Industries our inquiry is complete if the proper way to correct the error is not apparent from the face of the patent, even if the proper correction is clear from the prosecution history. Fargo is correct in so far as it argues that the prosecution history is to be consulted to determine whether the error is subject to only one reasonable construction. See Hoffer v. Microsoft Corp., 405 F.3d 1326, 1331 (Fed. Cir. 2005) (holding that claim 22, which depends from nonexistent claim 38, could be corrected because the error in the dependency was evident based on the face of the patent and that the correct antecedent claim was apparent from the prosecution history). The error must be

evident on the face of the patent, see Group One, Ltd. v. Hallmark Cards, Inc., 407 F.3d 1297, 1303 (Fed. Cir. 2005), but the prosecution history should be consulted to ascertain whether there is only a single reasonable construction. This is exactly what occurred in Hoffer and nothing in Novo Industries or Group One is to the contrary. The prosecution history cited on appeal by Fargo primarily focuses on distinguishing a prior art patent to make clear that the application's identifier indicia include removable magnetic material inserts rather than bar codes or stick-on labels. It does not, however, resolve the reasonable debate relating to the use of the terms "other than the" in claim 8. Thus, the prosecution history does not change the result in this case.

In light of the foregoing analysis, we are not persuaded by Fargo's arguments that all of the reasonable ways to correct the error result in the same claim scope and that the correction is not subject to reasonable debate. We conclude that the district court properly refused to correct claim 8. Accordingly, we affirm the district court's determination that claims 8 through 15 of the '519 Patent are invalid as indefinite. Summary Judgment Order, at *15-16.

C. Permissible Repair

Independent claim 8 and dependent claims 9 through 15 of the '519 Patent claim an ink ribbon supply roll. See '519 Patent col.7 l.46–col.8 l.45. Independent claims 1 and 5 and dependent claims 2, 3, 4, 6, and 7 of the '519 Patent claim combinations including an ink ribbon supply roll and other printer components, such as a detector. See '519 Patent col.6 l.61–col.7 l.45. Fargo alleges that IRIS infringes the '519 Patent contributorily or by inducement by selling infringing printer ribbon supply rolls used in combination with other components. "Fargo does not allege that Iris sells printers with

the accompanying detectors, . . . but only that Iris sells infringing printer ribbon supply rolls.” Summary Judgment Order, at *16.

As the district court noted, “[l]iability under § 271(b) and (c) is dependent on the existence of an underlying act of direct infringement.” Summary Judgment Order, at *16-17. After considering the relevant factors, including the fact that “[t]he printer ribbon is a readily replaceable part that must be replaced after a set number of uses,” the district court stated that “[t]he facts of this case fall squarely within these earlier precedents finding repair.” Id. at *19. Thus, the district court concluded that IRIS does not infringe combination claims 1 through 7 of the '519 Patent contributorily or by inducement because the reasonable repair doctrine applies such that there is not an underlying act of direct infringement. Id. at *23.

Fargo argues on appeal that “[b]ecause claim 8 of the '519 patent is valid, the district court erred in finding that IRIS cannot infringe claims 1-7 indirectly.” Appellant’s Br. 27. As IRIS notes, Fargo’s entire argument on appeal as to infringement of claims 1 through 7 of the '519 Patent is based on its contentions that the ribbon supply roll is separately patented and that the permissible repair doctrine is not available when a replacement component is separately patented. As discussed above, however, because claims 8 through 15 of the '519 Patent are invalid as indefinite, the ribbon supply roll is not separately patented. Thus, Fargo’s argument fails and we affirm the district court’s decision that IRIS does not infringe claims 1 through 7 of the '519 Patent contributorily or by inducement. Summary Judgment Order, at *23.

CONCLUSION

For the aforementioned reasons, we affirm the district court's final judgment of invalidity and noninfringement.