

United States Court of Appeals for the Federal Circuit

K-TEC, INC.,
Plaintiff-Appellee,

v.

VITA-MIX CORPORATION,
Defendant-Appellant,

2011-1244, -1484, -1512

Appeal from the United States District Court for the District of Utah in Case No. 06-CV-0108, Judge Tena Campbell.

Decided: September 6, 2012

BRETT L. FOSTER, Holland & Hart LLP, of Salt Lake City, Utah, argued for plaintiff-appellee. With him on the brief were L. GRANT FOSTER and MARK A. MILLER. Of counsel was MARCY G. GLENN, of Denver, Colorado.

ALAN L. BRIGGS, Squire, Sanders & Dempsey, LLP, of Washington, DC, argued for defendant-appellant. With him on the brief were JEREMY W. DUTRA, and RACHAEL A. HARRIS. Of counsel was BRAD YEE CHIN, of Vienna, Virginia.

Before NEWMAN, LOURIE, and PROST, *Circuit Judges*.

LOURIE, *Circuit Judge*.

Vita-Mix Corporation (“Vita-Mix”) appeals from the district court’s final judgment in which the court concluded that Vita-Mix infringed the asserted claims of two United States patents, *K-TEC, Inc. v. Vita-Mix Corp.*, Case No. 2:06-CV-0108, 2010 WL 1417862 (D. Utah Apr. 6, 2010) (“*Infringement Order*”), that two prior art references were not analogous art for the purposes of an obviousness analysis, *K-TEC, Inc. v. Vita-Mix Corp.*, 729 F. Supp. 2d 1312 (D. Utah 2010) (“*Analogous Art Order*”), that substantial evidence supported the jury’s findings that the asserted claims were not proved invalid, that Vita-Mix’s infringement was willful, and that K-TEC, Inc. (“K-TEC”) was entitled to approximately \$11 million in reasonable royalty and lost profits damages, *K-TEC, Inc. v. Vita-Mix Corp.*, 765 F. Supp. 2d 1304 (D. Utah 2011) (“*JMOL Opinion*”). On appeal, Vita-Mix challenges those conclusions in addition to other rulings made by the district court during trial. Because the district court did not err in any respect and the jury’s findings were properly supported, we *affirm*.

BACKGROUND

I.

This patent case relates to commercial blenders that are used to make blended beverages. K-TEC, a company that manufactures and sells commercial blending equipment, owns U.S. Patents 6,979,117 (“the ’117 patent”) and 7,281,842 (“the ’842 patent”), which generally disclose and claim a blending system that contains a blending jar with a specific geometry. The benefit of the claimed geometry is that it alters the flow pattern of the liquid during blending in a way that reduces cavitation, which occurs

when a pocket of air envelops the area surrounding the blender blade during blending. '842 patent, col.2 ll.11–15, col.7 ll.4–14.

The two patents are related—the '117 patent is the parent of the '842 patent. Claim 1 of the '842 patent is representative for the purposes of this appeal. It claims a “blending jar” that comprises “four side walls” and a “fifth truncated wall” arranged in a specific geometry:

1. A blending jar apparatus, comprising:

a blending jar having a blending element which rotates on a central axis, the jar to hold at least one foodstuff to be blended, the blending jar comprising:

a bottom wall;

four side walls extending from the bottom wall, the four side walls defining an opening having a generally rectangular shape, the opening being configured to receive the at least one foodstuff;

a fifth truncated wall disposed between two of the four side walls;

a handle secured to the blending jar adjacent to the fifth truncated wall;

wherein the fifth truncated wall is positioned closer to the central axis than corners formed by the four side walls.

Id. col.8 ll.17–31 (emphases added). The written description details the claimed geometry. In particular, Figure 11, reproduced below, depicts the claimed jar, with four side walls, labeled 132, 134, 136, and 138, and a fifth truncated wall, labeled 135.

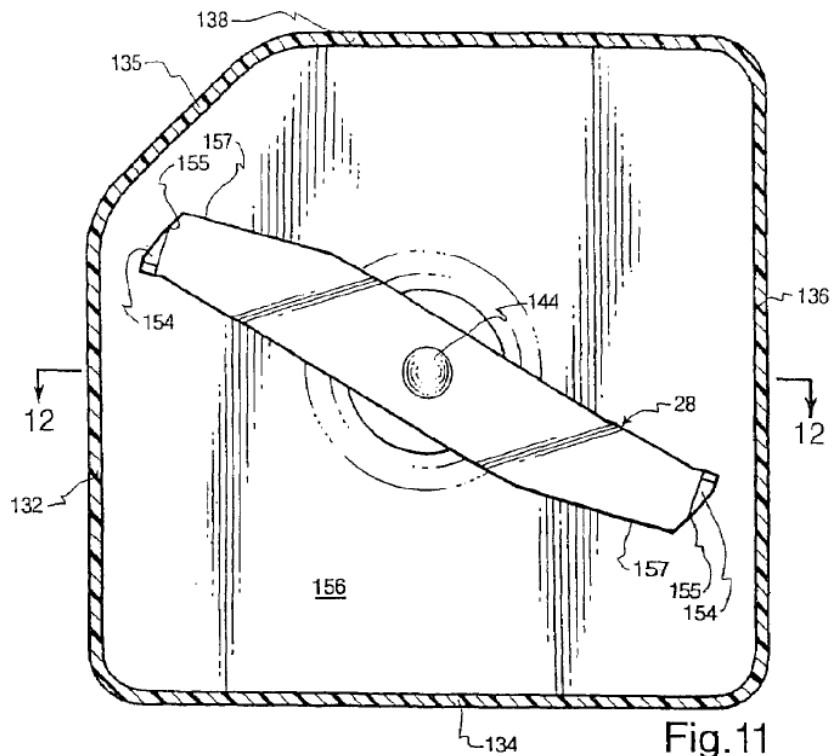

In the above figure, the fifth truncated wall is disposed between side walls 138 and 132 and is positioned closer to the blending jar's central axis 144 than the corners formed by the four side walls. *See id.* col.6 l.58–col.7 l.14. The written description explains that the fifth wall “truncates, in essence, the typical corner that would otherwise be formed between wall 132 and 138.” *Id.* col.6 ll.62–64. Similarly, K-TEC explained to the U.S. Patent & Trademark Office (“PTO”) that the truncated wall “may be planar or curved, as long as it truncates a typical corner that would otherwise be formed if the truncated wall were not present.” *K-TEC, Inc. v. Vita-Mix Corp.*, No. 2:06-CV-0108, 2009 WL 3568623, at *2 (D. Utah Oct. 23, 2009) (“*Claim Construction Opinion*”). The corners created by the sidewalls “may be formed at generally

right angles,” ’117 patent, col.6 ll.60–62, although the specification depicts them also as rounded.

As a result of this geometry, the vortex created when blending liquid inside the container moves away from the central axis and toward the truncated wall. ’842 patent, col.7 ll.4–14. The shifted vortex creates a flow pattern in which, during blending, the liquid will climb up the corner opposite the truncated wall and will be lower at the truncated wall. *Id.* col.7 ll.9–12. That flow pattern reduces cavitation in the container, increasing the speed and efficiency with which smoothies and other beverages can be made. *Id.* col.7 ll.12–14.

K-TEC and Vita-Mix compete in the market for commercial blenders. In 2001, K-TEC began selling a five-sided blending jar that was an embodiment of the ’117 and ’842 patents’ claims. After K-TEC acquired a number of customers in 2001 and 2002, Vita-Mix began to consider upgrading its existing four-sided container. In that process, its “example” design was K-TEC’s five-sided container. J.A. 16507, 16511. Although Vita-Mix attempted different design changes, it introduced its new MP container in May 2003, a design that Vita-Mix personnel admitted was a copy of K-TEC’s five-sided container. J.A. 25455–46.

After Vita-Mix released the MP container, K-TEC notified Vita-Mix in March 2005 that the container infringed the parent patent of the ’117 and ’842 patents. In late 2005, one of K-TEC’s employees notified Vita-Mix personnel that the ’117 patent would soon issue and that Vita-Mix’s MP container would infringe that patent. The day after the patent issued, the record shows that Vita-Mix’s CEO knew that “the K-Tec patent for the MP container” had issued, J.A. 16619.

During that period, Vita-Mix began attempting to design around the '117 patent. In that process, Vita-Mix's executives sought a change that would be "as invisible as possible" to Vita-Mix's customers. J.A. 25439–40. Vita-Mix considered over a dozen noninfringing designs, including an equidistant design that it believed did not infringe because it lacked a "truncated corner." J.A. 25445–46. Ultimately, however, Vita-Mix opted for a design, referred to as the XP container, in which the planar fifth wall was no longer "flat" but became curved, i.e., it had a "radius." J.A. 25437; *see also* J.A. 25418 (explaining that Vita-Mix's XP container differed from the MP container in that "[t]he one corner was rounded"). Below is a photograph of a cross-section of the XP container that Vita-Mix submitted to the district court during the proceedings, with the annotations provided by Vita-Mix.

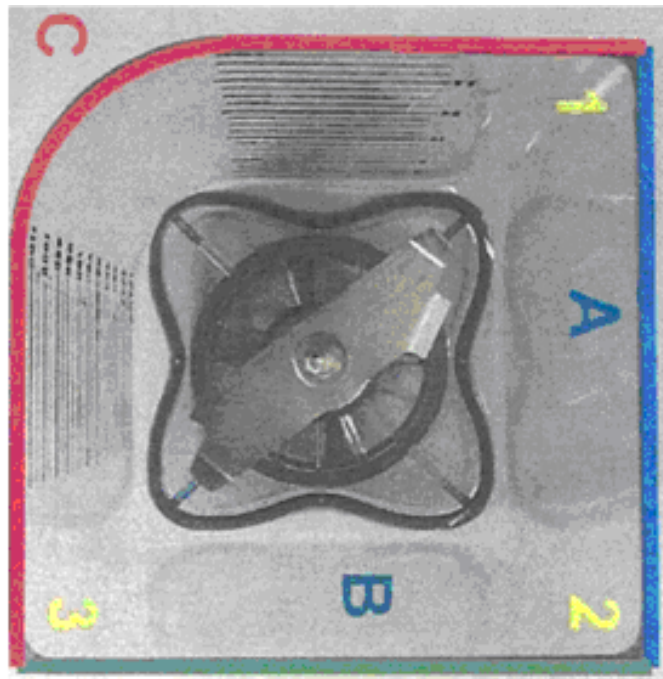

Although Vita-Mix altered the design to include a curved portion, it maintained the same item numbers for the XP container that it used for the MP container. As a result, Vita-Mix concluded that it had created a container that was “equal to our old design in blending performance” and that most of its customers would “never even notice the change.” J.A. 16594.1. After the XP product was launched, Vita-Mix decided to halt sales of the MP container. *See id.*

II.

Shortly after the '117 patent issued, K-TEC sued Vita-Mix in the United States District Court for the District of Utah, alleging that the MP container infringed a number of claims of the '117 patent. Thereafter, K-TEC amended its complaint to include the '842 patent and the XP container. Ultimately, K-TEC pursued damages only for sales of the XP container.

During the proceedings, the district court arrived at a number of conclusions that serve as the basis for Vita-Mix's appeal. First, the district court, after rejecting Vita-Mix's claim construction arguments, construed the “fifth truncated wall” limitation to mean “a wall (planar or non-planar) that truncates, in essence, the typical corner that would otherwise be formed between two side walls.” *Claim Construction Opinion*, 2009 WL 3568623, at *1, *3.

Second, prior to trial, the court granted K-TEC's motion for summary judgment that the XP container infringed the asserted claims and partially granted K-TEC's motion that the asserted claims are not invalid. Regarding infringement, the court concluded based on a “visual inspection” of the XP container that there was no genuine issue that the container had “four side walls that form intersecting corners and a fifth nonplanar wall between two of the side walls that truncates the typical corner that

would be formed between the two side walls.” *Infringement Order*, 2010 WL 1417862, at *2. In partially granting K-TEC’s motion upholding the validity of the ’117 and ’842 patents, the court concluded that Vita-Mix had failed to raise a genuine issue of material fact that two non-blender designs that depict five-sided containers, U.S. Design Patents 163,117 (“Hobbs”) and 227,535 (“Grimes”), would have been reasonably pertinent to solving the cavitation problem that the ’117 and ’842 patents’ inventor faced when he conceived those inventions. *Analogous Art Order*, 729 F. Supp. 2d at 1323–24.

At the same time, Vita-Mix moved for summary judgment that the “fifth truncated wall” limitation rendered the claims invalid for indefiniteness because the district court’s construction included the word “typical.” In denying Vita-Mix’s motion, the court clarified its earlier construction, explaining that “the term ‘typical corner’ refers to a corner that, but for the addition of the truncated wall, would otherwise be typical—or in other words identical—to the other corners of the blending jar.” *K-TEC, Inc. v. Vita-Mix Corp.*, No. 2:06-CV-0108, 2010 WL 1816266, at *3 (D. Utah May 3, 2010) (“*Indefiniteness Order*”). After the parties disputed which particular language applied in their proposed jury instructions, the district court held that the clarified construction in the summary judgment decision applied.

In parallel with the district court proceedings, Vita-Mix initiated *inter partes* reexaminations of the ’117 and ’842 patents. In reexamination, the PTO considered a number of references that were not before the agency during prosecution, including U.S. Patent 6,431,744 (“Ash”), a reference that Vita-Mix relied on at trial. While Vita-Mix raised a substantial new question of patentabil-

ity to initiate the proceedings, K-TEC ultimately prevailed.¹

In 2010, the parties tried the remaining invalidity, willfulness, and damages issues to a jury, which found in favor of K-TEC on all issues. To support its invalidity case, Vita-Mix primarily relied on Ash and U.S. Patent 7,063,456 (“Miller”). Ash discloses a blender hopper with a larger upper portion and a smaller lower portion. Ash, Abstract. The upper portion is generally rectangular and the lower portion is octagonal. *Id.* at Fig. 4. To achieve this change in shape, triangular walls narrow the hopper from the upper portion to the lower portion. *Id.* Vita-Mix contends that, as a matter of law, the triangular walls in Ash meet the “fifth truncated wall” claim limitation and that the remaining walls meet the “four side walls” limitation. Figure 1 of Ash, a portion of which is depicted below, shows the geometry of the blender hopper:

¹ We affirmed without opinion Vita-Mix’s appeal from the decision of the Board of Patent Appeals & Interferences (“the Board”) in Reexamination No. 95/000,339 regarding the ’842 patent. Vita-Mix’s appeal to this court regarding the reexamination of the ’117 patent remains pending. *See Vita-Mix Corp v. Kappos*, Appeal No. 2012-1447.

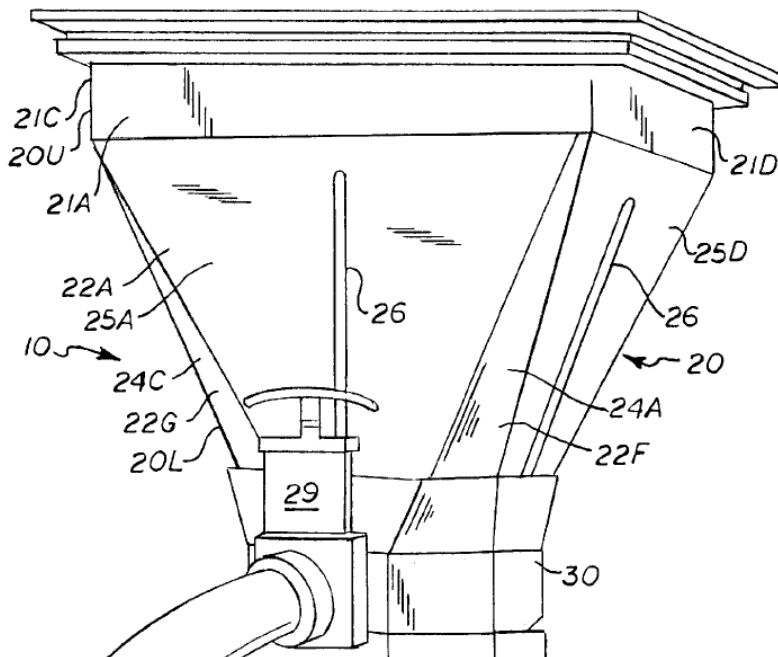

During the trial, the district court allowed the parties to offer evidence on whether the PTO had considered Ash in finding the asserted claims patentable. In addition, at the close of the evidence, the court instructed the jury that while Ash was not considered in prosecution, “[a]t some time later in the proceedings, the PTO had in front of it the Ash Patent.” Jury Instructions, *K-TEC, Inc. v. Vita-Mix Corp.*, No. 2:06-CV-0108 (D. Utah June 17, 2010), ECF No. 770, at 21.

Regarding Miller, Vita-Mix contests on appeal the district court’s instructions regarding the reference and related cross-examination. Prior to trial, the court precluded Vita-Mix from presenting evidence or argument at trial relating to sketches, notes, and experiments from Mr. Miller disclosing a “square-within-a-square” concept because they were not prior art, *K-TEC, Inc. v. Vita-Mix Corp.*, No. 2:06-CV-0108, 2010 WL 1486781, at *1–2 (D.

Utah Apr. 13, 2010), a decision that Vita-Mix does not contest here. At trial, Vita-Mix presented Mr. Miller as a witness, and during his live testimony, the district court concluded that Miller strayed into discussing the previously-excluded evidence. J.A. 12948–51. As a result, the court instructed the jury to confine its invalidity analysis to “the words of the [Miller] patent and the drawings” but that, as determined in the court’s summary judgment opinion, Miller did not describe “a blending jar of a square within a square or such.” J.A. 12975–76.

The court also allowed K-TEC to cross-examine Mr. Miller based on the PTO’s statements in an office action for an application related to the Miller reference. Specifically, the court allowed K-TEC’s counsel to ask a series of “would it surprise you” questions based on the examiner’s conclusions in the office action. *See* J.A. 13000–07. However, K-TEC never introduced the prosecution history into evidence and the court did not allow Miller to see that history. J.A. 13001.

After the jury returned a verdict in favor of K-TEC, the district court denied Vita-Mix’s post-trial motions, concluding that substantial evidence supported the jury’s factual findings on anticipation, willfulness, and damages, and that Vita-Mix was not entitled to judgment as a matter of law. *JMOL Opinion*, 765 F. Supp. 2d at 1311–16. The district court thereafter entered judgment against Vita-Mix, from which it timely appealed. We have jurisdiction under 28 U.S.C. § 1295(a)(1).

DISCUSSION

I.

We apply the law of the regional circuit, here the Tenth Circuit, to review the district court’s denial of Vita-Mix’s motion for judgment as a matter of law. *Voda v.*

Cordis Corp., 536 F.3d 1311, 1318 (Fed. Cir. 2008). The Tenth Circuit reviews a denial of a motion for judgment as a matter of law *de novo*, applying the same legal standard as the district court. *Equal Emp't Opportunity Comm'n v. Heartway Corp.*, 466 F.3d 1156, 1160 (10th Cir. 2006). Judgment as a matter of law is only appropriate if the record, viewed in the light most favorable to the prevailing party, lacks substantial evidence to support the jury's findings. Fed. R. Civ. P. 50(a); *United Int'l Holdings, Inc. v. Wharf (Holdings) Ltd.*, 210 F.3d 1207, 1227 (10th Cir. 2000).

A grant of summary judgment is also reviewed *de novo*. *Eisai Co. Ltd. v. Dr. Reddy's Labs., Ltd.*, 533 F.3d 1353, 1356 (Fed. Cir. 2008). Summary judgment is appropriate if the movant "shows that there is no genuine dispute as to any material fact and the movant is entitled to judgment as a matter of law." Fed. R. Civ. P. 56(a). In deciding that issue, we credit all of the non-movant's evidence and draw all justifiable inferences in its favor. *Anderson v. Liberty Lobby, Inc.*, 477 U.S. 242, 255 (1986).

Finally, we review evidentiary rulings under the law of the regional circuit. *Utah Med. Prods., Inc. v. Graphic Controls Corp.*, 350 F.3d 1376, 1381 (Fed. Cir. 2003). The Tenth Circuit reviews evidentiary rulings under an abuse of discretion standard. *Pandit v. Am. Honda Motor Co.*, 82 F.3d 376, 379 (10th Cir. 1996). Under that standard, "a trial court's decision will not be disturbed unless the appellate court has a definite and firm conviction that the lower court made a clear error of judgment or exceeded the bounds of permissible choice in the circumstances." *Boughton v. Cotter Corp.*, 65 F.3d 823, 832 (10th Cir. 1995) (quoting *McEwen v. City of Norman*, 926 F.2d 1539, 1553 (10th Cir. 1991)). Even if that standard is met, "we will set aside a jury verdict only if the error prejudicially

affects a substantial right of a party.” *Hinds v. Gen. Motors Corp.*, 988 F.2d 1039, 1049 (10th Cir. 1993).

II.

Vita-Mix raises numerous issues on appeal. First, Vita-Mix argues that the district court erred in granting summary judgment that the XP container infringed the asserted claims. Vita-Mix highlights that it provided expert testimony that showed under the court’s construction how the XP container had three walls, not the “four side walls” or the “fifth truncated wall” limitations of the asserted claims. That testimony, according to Vita-Mix, raised a genuine issue of material fact for trial.

K-TEC responds that Vita-Mix raises claim construction issues, not a genuine factual dispute about the structure of the XP container. K-TEC argues that the intrinsic record supports the district court’s construction that the claimed “truncated wall” may be curved. Regarding the XP container’s structure, K-TEC argues that there is no genuine dispute that the container contained four side walls and a curved fifth truncated wall.

We agree with K-TEC that the district court properly entered summary judgment of literal infringement. In the summary judgment context, “[a] party does not manufacture more than a merely colorable dispute simply by submitting an expert declaration asserting that something is black” when no reasonable juror reviewing the evidence could reach such a conclusion. *Invitrogen Corp. v. Clontech Labs., Inc.*, 429 F.3d 1052, 1080 (Fed. Cir. 2005). That maxim is especially true in cases involving relatively simple technology, such as this one, because “the technology will be ‘easily understandable without the need for expert explanatory testimony.’” *Centricut, LLC v. Esab Group, Inc.*, 390 F.3d 1361, 1369 (Fed. Cir. 2004)

(quoting *Union Carbide Corp. v. Am. Can Co.*, 724 F.2d 1567, 1573 (Fed. Cir. 1984)).

In this case, despite Vita-Mix's and its expert's attempt to redraw the XP container, there is no genuine dispute that the container has the claimed four side walls and fifth truncated wall. The XP container's geometry matches that of the claimed blending jar, which generally has side walls that are "arranged in a generally rectangular, tapered shape," '842 patent col.6 ll.58–62, although those walls need not be planar, *id.* col.8 ll.22–27, 45–49. Likewise, the asserted patents also explain that while the fifth truncated wall need not be planar, *id.*, it truncates, "in essence, the typical corner that would otherwise be formed" between the side walls, *id.* col.6 ll.62–64; *see also Claim Construction Opinion*, 2009 WL 3568623, at *2. There is no genuine dispute that the XP container's geometry falls within that claim limitation. Indeed, a visual comparison of Fig. 11 of the asserted patents and Vita-Mix's annotation of the XP container further shows that the district court properly granted K-TEC's motion for summary judgment.

III.

Second, Vita-Mix argues that the district court erred in granting summary judgment that Grimes and Hobbs are not analogous art. To support its argument that those references were reasonably pertinent art, Vita-Mix points to the inventor's deposition testimony that the problems he confronted during the development of the patented jar included designing a jar that would fit within a particular dimension. Vita-Mix also points to its expert's report on invalidity. Finally, Vita-Mix points to the PTO's reexamination of the '117 patent, in which the Board held that Hobbs and Grimes were analogous art.

K-TEC responds that the ornamental designs of containers had no bearing on the inventor's cavitation problem, a problem specific to the field of blenders. K-TEC argues that the size of the container and the jar's hand clearance were not problems in the prior art. Finally, K-TEC argues that even if Hobbs and Grimes are analogous prior art, inclusion of those references would not have had a material effect on the district court's determination of obviousness.

We agree with K-TEC that the district court properly granted summary judgment that Grimes and Hobbs are not analogous art. To qualify as prior art for an obviousness analysis, a reference must qualify as "analogous art," *i.e.*, it must satisfy one of the following conditions: (1) the reference must be from the same field of endeavor; or (2) the reference must be reasonably pertinent to the particular problem with which the inventor is involved. *Innovation Toys, LLC v. MGA Entm't, Inc.*, 637 F.3d 1314, 1321 (Fed. Cir. 2011). A reference is reasonably pertinent if it, as a result of its subject matter, "logically would have commended itself to an inventor's attention in considering his problem." *Id.*

Here, Vita-Mix does not dispute that Hobbs and Grimes are not in the same field of endeavor as the '117 and '842 patents. However, Vita-Mix also failed to raise a genuine issue of material fact that the references would have been reasonably pertinent the inventor in considering his problem.

First, the inventor's testimony, by itself, failed to raise a genuine issue of material fact that Hobbs and Grimes would have been considered reasonably pertinent art. According to the specification, there are four prior art problems that the invention solves: blender speed, safety, cavitation, and the blender's ability to blend frozen ingre-

dients. '842 patent col.1 l.52–col.2 l.23. Consistent with that description, the inventor testified that he sought to create a blending jar that “would reduce or prevent cavitation when blending frozen drinks.” J.A. 7583; *see generally* J.A. 7583–86 (same). While the inventor’s testimony also mentioned that, in developing the patented jar, he also wanted the resulting jar to fit within K-TEC’s existing quiet box, there is no dispute that creating a smaller jar was not the problem he set out to solve because K-TEC’s existing jars already fit within the quiet box. Thus, the inventor’s testimony does not raise a genuine issue of material fact.

Second, Vita-Mix’s expert’s report on invalidity failed to raise a genuine issue of material fact because, as the district court correctly concluded, the report was “silent on the question of why [the inventor] would have looked to non-blending containers to discover the[] commonplace designs” depicted in Hobbs and Grimes. *Analogous Art Order*, 729 F. Supp. 2d at 1324. Indeed, the report did not address the Grimes reference. *Id.* at 1324 n.3. Ultimately, the district court rightly concluded that the report did not “explain any rational underpinning for [the inventor] to have consulted non-blending containers or food mixers in order to solve the problems he encountered in designing a new blending container,” and properly concluded that the report failed to raise a genuine issue of material fact. *Id.* at 1324.

Finally, the Board’s decision that Hobbs and Grimes were analogous art does not raise a genuine issue of material fact. As an initial matter, the district court did not have the benefit of the Board’s analysis because the Board’s opinion did not issue until well after the district court entered final judgment in this case. But, regardless whether we consider such post-judgment events in this appeal, *see Marine Polymer Techs., Inc. v. HemCon, Inc.*,

672 F.3d 1350, 1362 (Fed. Cir. 2012) (en banc), summary judgment was appropriate in this case. Here, it was Vita-Mix's burden before the district court to proffer evidence such that a reasonable juror could find the '117 and '842 patents invalid under the clear and convincing standard of proof. As recounted above, Vita-Mix failed to meet that burden.

IV.

Next, Vita-Mix argues that the district court denied it a fair trial, pointing to four alleged errors. First, Vita-Mix argues that the district court erred when it informed the jury that the PTO had considered Ash, because the agency did not consider Ash during the prosecution of the asserted claims but, at the time of trial, was considering Ash in the ongoing reexamination proceedings. Second, Vita-Mix contends that the district court changed the construction of "truncated wall" during trial to an incorrect construction and prejudiced Vita-Mix as a result. Third, Vita-Mix asserts that the district court permitted improper impeachment of Vita-Mix's principal invalidity witness, Mr. Miller, with inadmissible hearsay evidence from the prosecution history of a continuation application of the Miller patent. Finally, Vita-Mix argues that the district court improperly commented on Miller's disclosure. In toto, argues Vita-Mix, these errors entitle it to a new trial.

We disagree. First, it was not an abuse of discretion to allow the parties to discuss the extent to which the PTO had considered Ash or instruct the jury that Ash was before the PTO in the reexamination proceedings. It is generally true that evidence of non-final reexamination determinations is of little relevance and presents a risk of jury confusion. *Callaway Golf Co. v. Acushnet Co.*, 576 F.3d 1331, 1342–43 (Fed. Cir. 2009) (applying Third

Circuit law). But it is the province of the district court to weigh those interests and determine admissibility in each case, a decision about which the court has very broad discretion. *Webb v. ABF Freight Sys., Inc.*, 155 F.3d 1230, 1246 (10th Cir. 1998). In this case, the court determined that the probative value of the evidence was not substantially outweighed by the potential of the evidence to unfairly prejudice Vita-Mix, cause confusion of the issues, or mislead the jury. *See* Fed. R. Evid. 403. Indeed, the court explained the status of the reexamination proceedings to the jury and, if anything, cured any potential unfair prejudice to Vita-Mix by informing the jury that the PTO's consideration of Ash in the reexaminations proceedings "ha[d] really no value." J.A. 13840.

Second, the district court did not cause unfair prejudice to Vita-Mix by changing its construction of "truncated wall" prior to trial. Instead, the court simply clarified its construction by formally incorporating its rejection of Vita-Mix's claim construction positions. The court's *Indefiniteness Order* provided Vita-Mix with ample notice that it could not recycle its rejected claim construction arguments as part of its invalidity case. And rather than clarify any potential ambiguity sufficiently before trial, Vita-Mix chose to wait until the eve of trial—when it submitted its proposed jury instructions—to re-raise its claim construction position. In any event, Vita-Mix has failed to show error in the court's clarified construction, which finds support in the intrinsic record. *See Indefiniteness Order*, 2010 WL 1816266, at *3 (citing reexamination history); '842 patent, Figs. 10–13, col.6 l.38–col.7 l.14 (describing jar with identical corners but for the truncated wall).

Third, Vita-Mix has failed to show that the district court abused its discretion by allowing K-TEC to cross-examine Mr. Miller based on the prosecution history from

a patent application related to the Miller reference. It was not an abuse of discretion to conclude that K-TEC did not offer the prosecution history for the truth of the statements therein, *see* Fed. R. Evid. 801(c), and the statements from the prosecution history were never introduced into evidence.

Finally, Vita-Mix has not shown that the district court erred in instructing the jury regarding Miller. After reviewing the record, it appears that the district court's comments were tailored to enforcing its prior summary judgment order that excluded evidence that Vita-Mix failed to prove was prior art, a decision that Vita-Mix does not appeal.

In sum, Vita-Mix has failed to show that the district court denied it a fair trial.

V.

Vita-Mix also argues that the district court erred in denying its motion for judgment as a matter of law that the Ash reference invalidates the asserted claims. Vita-Mix argues that Ash plainly discloses the claimed “four side walls” and “fifth truncated wall” required by the asserted claims. Regarding the claims that additionally require a handle, Vita-Mix argues that it would have been obvious as a matter of law to modify the blending container disclosed in Ash to include a handle, citing a number of prior art references that disclose blending containers with handles.

In response, K-TEC argues that Ash does not disclose the claimed “truncated wall” because the reference does not truncate a typical corner that would otherwise be formed between the sidewalls and does not disclose corners that are formed by sidewalls. K-TEC also points to testimony by both parties' technical experts as supporting

evidence. Regarding Vita-Mix's obviousness arguments, K-TEC argues that substantial evidence demonstrates that it would not have been obvious to add a handle to Ash because the hopper in Ash is not a pouring vessel. K-TEC also points to objective evidence such as commercial success and Vita-Mix's attempts to copy K-TEC's five-sided blending container.

We agree with K-TEC that Vita-Mix is not entitled to judgment as a matter of law that the asserted claims are invalid. To prove that a claim is invalid for anticipation, "the accused infringer must show by clear and convincing evidence that a single prior art reference discloses each and every element of a claimed invention." *Silicon Graphics, Inc. v. ATI Techs., Inc.*, 607 F.3d 784, 796 (Fed. Cir. 2010). Here, K-TEC presented substantial evidence from which a jury could reasonably find that Ash does not disclose the claimed "fifth truncated wall." As K-TEC's expert testified, it appears from the reference that what Vita-Mix identified as truncated walls are simply sidewalls that form typical transitional corners and do not truncate an otherwise typical corner. *See* J.A. 14071-82. Even if the triangular walls served as "truncated walls" as a matter of law, K-TEC proffered substantial evidence that Ash would then fail to disclose the "corners formed by the four sidewalls" limitation because, at the heights at which Ash discloses a truncated wall, the reference only discloses corners formed by the intersection of truncated walls and sidewalls, not corners formed between two sidewalls. *Compare* Ash, Fig.1, with '842 patent, Fig. 10.

Regarding obviousness, it was Vita-Mix's burden to prove by clear and convincing evidence that the claimed subject matter "as a whole would have been obvious at the time the invention was made" to those skilled in the art. 35 U.S.C. § 103(a). Here, Vita-Mix argues that it would have been obvious to modify the Ash reference to include

a handle. Vita-Mix does not argue, however, that it would have been obvious to modify Ash to include a fifth truncated wall, and nothing in the record indicates that modifying Ash to include a fifth truncated wall would have been obvious as a matter of law. In addition, Ash discloses not a fifth truncated wall, but four flat corners, none of which is closer to the central axis, a required claim limitation. Accordingly, the district court correctly denied Vita-Mix's motion for judgment as a matter of law that the asserted claims are invalid.

VI.

Fifth, Vita-Mix argues that the district court erred in denying its motion for judgment as a matter of law that it did not willfully infringe the asserted claims. Specifically, Vita-Mix argues that because its above-described noninfringement and invalidity positions were reasonable, K-TEC failed to establish objective recklessness as a matter of law. Vita-Mix argues that, at every stage, it acted reasonably and in good faith by designing around the asserted claims and initiating reexamination of the asserted claims.

We disagree. To prevail on an allegation of willful infringement, the patentee must prove (1) that the accused infringer "acted despite an objectively high likelihood that its actions constituted infringement of a valid patent"; and (2) that this objectively defined risk was either known or so obvious that the accused infringer should have known about it. *In re Seagate Tech., LLC*, 497 F.3d 1360, 1371 (Fed. Cir. 2007) (en banc).

Here, Vita-Mix has failed to show that the district court erred in denying its motion for judgment as a matter of law regarding willfulness. Vita-Mix's noninfringement theory and most of its invalidity theories were properly disposed of on summary judgment. Its remain-

ing theories were soundly rejected by the jury. In addition, as recounted above, K-TEC presented evidence that, in designing the XP product, Vita-Mix started with the MP container—a direct copy of K-TEC’s five-sided jar—and made only a trivial change. Specifically, K-TEC offered evidence that, rather than adopting one of numerous noninfringing designs, Vita-Mix opted for a design that allowed Vita-Mix to produce a container that performed in the same way as the MP container and employ a design that its customers would not be able to distinguish from the MP container. Indeed, Vita-Mix maintained the same product numbers for both the MP and XP containers. Similarly, K-TEC presented substantial evidence that Vita-Mix knew of the objectively high risk of infringing K-TEC’s valid patents but decided to proceed anyway. In view of this record, we cannot conclude that the district court erred in denying Vita-Mix’s motion for judgment as a matter of law on willful infringement.

VII.

Lastly, Vita-Mix argues that the district court erred in denying its motion for judgment as a matter of law that K-TEC failed to adequately prove damages. Vita-Mix argues that K-TEC did not provide actual notice that the XP container infringed the ’117 patent until April 7, 2006, when K-TEC amended its complaint to allege infringement of the XP container. Thus, argues Vita-Mix, K-TEC failed to proffer sufficient evidence of damages because its damages expert employed an accounting period that began on December 27, 2005, prior to the date when K-TEC provided notice to Vita-Mix. Accordingly, Vita-Mix requests that this case be remanded for a new trial on damages.

We disagree. In the absence of marking a patented article, a patentee who makes, offers for sale or sells a

patented article must notify a party of the infringement for damages to accrue. 35 U.S.C. § 287(a). If a patentee's initial notice is sufficiently specific to accuse one product of infringement, "ensuing discovery of other models and related products may bring those products within the scope of the notice." *Funai Elec. Co. v. Daewoo Elecs. Corp.*, 616 F.3d 1357, 1373 (Fed. Cir. 2010). Here, K-TEC proffered evidence that (1) it provided notice that the MP container infringed various claims of the '117 patent's parent patent in March 2005; (2) it provided subsequent notice to Vita-Mix that the MP container infringed the '117 patent's claims in late October 2005; (3) its notice resulted in Vita-Mix having actual notice of the '117 patent, which its CEO referred to as "the K-Tec patent for the MP container," when the patent issued on December 27, 2005, J.A. 16619; and (4) Vita-Mix treated the XP and MP containers as related products, *see, e.g.*, J.A. 16594.1 (explaining that both products will use the same item numbers and that most of Vita-Mix's customers "will never even notice the change" from the MP to the XP). In light of this evidence, the district court did not err in denying Vita-Mix's motion for judgment as a matter of law on damages. No substantial challenge is made on appeal concerning the amount of the damages found by the jury.

CONCLUSION

We have considered Vita-Mix's remaining arguments and conclude that they are without merit. For the foregoing reasons, the judgment of the district court is

AFFIRMED