

**United States Court of Appeals
for the Federal Circuit**

RAYLON, LLC,
Plaintiff-Appellee,

v.

COMPLUS DATA INNOVATIONS, INC.,
Defendant-Appellant,

AND

**CASIO AMERICA, INC. AND CASIO COMPUTER
CO., LTD.,**
Defendants-Appellants,

AND

SYMBOL TECHNOLOGIES, INC.,
Defendant-Appellant,

AND

**ADVANCED PUBLIC SAFETY, INC., TRIPOD DATA
SYSTEMS, ZEBRA
TECHNOLOGIES CORPORATION, EZ TAG
CORPORATION, FUJITSU AMERICA,
INC. AND FUJITSU JAPAN LTD.,**
Defendants.

2011-1355, -1356, -1357, -1358, -1359

Appeal from the United States District Court for the Eastern District of Texas in No. 09-CV-0355, 09-CV-0356, 09-CV-0357, Judge Leonard Davis.

Decided: December 7, 2012

D. SCOTT HEMINGWAY, Hemingway & Hansen LLP, of Dallas, Texas, argued for the plaintiff-appellee. On the brief was AMANDA ABRAHAM, Roth Law Firm, of Marshall, Texas.

JOHN R. EMERSON, Haynes and Boone, LLP, of Dallas, Texas, argued for the defendant-appellant Complus Data Innovations, Inc. With him on the brief were DEBRA J. MCCOMAS, DONALD EDWARD TILLER and SEAN M. O'NEILL.

SCOTT D. STIMPSON, Sills Cummis & Gross P.C., of New York, New York, argued for defendant-appellants Casio Computers Co. Ltd, et al. With him on the brief were KATHERINE M. LIEB and DAVID C. LEE.

MITCHELL S. FELLER, Sobel & Feller, of New York, New York, argued for defendant-appellant Symbol Technologies, Inc. With him on the brief was JONATHAN M. SOBEL.

Before PROST, MOORE, and REYNA, *Circuit Judges*.

Opinion for the court filed by *Circuit Judge* PROST.

Concurring opinion filed by *Circuit Judge* REYNA.

PROST, *Circuit Judge*.

Raylon, LLC (“Raylon”) brought three suits against, inter alia, Complus Data Innovations, Inc. (“Complus”), Casio America, Inc. and Casio Computer Co., Ltd., (collectively “Casio”), and Symbol Technologies, Inc. (“Symbol”) (collectively, “defendants”) in the Eastern District of Texas. Raylon alleged that all defendants infringe claims 1-17 of U.S. Patent No. 6,655,589 (“’589 patent”). The district court consolidated the three suits. After a combined hearing, the court adopted defendants’ claim construction, granted summary judgment in their favor, and denied their motions for Rule 11 sanctions. The district court also denied defendants’ motions for attorneys’ fees and costs under 35 U.S.C. § 285, citing its Rule 11 decision. Defendants appeal the denial of sanctions and attorneys’ fees. For the reasons set forth below, we affirm in part, vacate in part, and remand for further proceedings.

BACKGROUND

Raylon is the assignee of the ’589 patent, which is directed to a hand-held identification investigating and ticket issuing system. The object of the invention is to provide an affordable, durable system that reduces the amount of time a user spends identifying and issuing tickets to individuals and allows the user to maintain visual contact with the individual throughout the identification and ticketing process. ’589 patent col.2 ll.64-65; col.3 ll.34-48. The system is described as containing a housing within which there is an input assembly for entering data, an elongated slot for receiving identification forms that have a magnetic tape, an elongated aperture for access to the housing’s interior, a transceiver assembly to communicate remotely with a computer, a

printer assembly for printing tickets, and a display that “is pivotally mounted on the housing for displaying data entered into the input assembly.” See, e.g., ’589 patent Abstract; col.1 ll.26-40; col.1 l.66–col.2 l.14; col.3 ll.18-33. Figure 1 is a schematic perspective of the system:

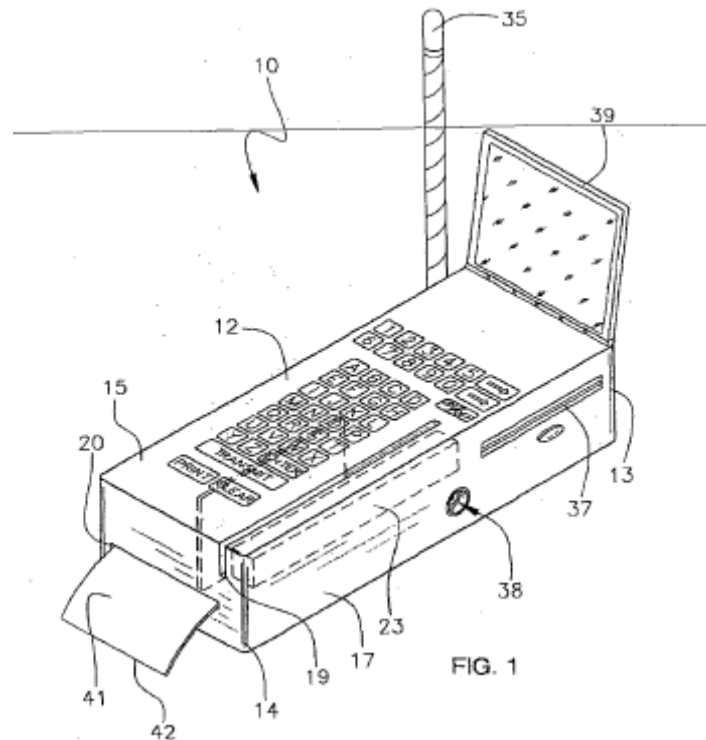

With reference to Figure 1, the preferred embodiment’s display **39** “may be pivotally mounted on the housing **12** and may be positioned generally adjacent to the first end **13** of the housing **12**.” *Id.* col.5 ll.58-61. Claim 1 is representative of the patented system:

1. A system for investigating an identification of a person and for issuing tickets, the identification comprising a card having a computer readable magnetic tape secured on the card, the computer readable magnetic tape containing pertinent data

relating to the person displayed on the identification card, said system being connectable to a computer for transmitting data between said system and the computer, said system being connectable to a data cable of a computer, said system comprising:

a housing having an interior, said housing having an elongated slot for selectively receiving the identification card, said housing having an elongated aperture providing access into said interior of said housing;

an input assembly for inputting data about a person, said input assembly being mounted on said housing, said input assembly including a data reading means for reading the computer readable magnetic tape on the identification card;

a transceiver assembly for remotely communicating with a computer, said transceiver assembly being mounted in said interior of said housing;

a display for displaying data entered into said input assembly, *said display being pivotally mounted on said housing*;

a printer assembly being mounted in said interior of said housing for printing a ticket; and wherein said printer assembly includes

a substrate for receiving indicia, said substrate including an end extendable through said elongated aperture in said housing,

a printer means for printing indicia on said substrate, and

means for advancing said substrate with respect to said printer means such that substrate is advanced through said elon-

gated aperture in said housing when said printer means prints indicia on said substrate.

Id. col.7 ll.9-44 (emphasis added). Independent system claims 16 and 17 also recite a “display being pivotally mounted on said housing” limitation. *Id.* col.8 ll.55-57; col.9 ll.20-22.

In 2009, Raylon filed three suits in the U.S. District Court for the Eastern District of Texas against software integrators and product component manufacturers of various ticket-writing and enforcement handheld devices, including Complus, Casio, and Symbol. In each suit, Raylon asserted that defendants’ devices directly infringe claims 1-17 of the ’589 patent literally and under the doctrine of equivalents, that defendants induce others to infringe, and that defendants contributorily infringe all claims of the ’589 patent. Defendants moved to dismiss, for judgment on the pleadings, or for summary judgment; the court denied or postponed these motions pending claim construction.

During the spring of 2010, Casio and other defendants sent several letters to Raylon, expressing their concerns that Raylon’s complaints violated Rule 11(b)(2) and Rule 11(b)(3) because, inter alia, Raylon’s claim construction positions were unsupported by intrinsic evidence and its infringement positions with regards to the display, magnetic strip reader, and printer elements of the asserted claims were unreasonable. Raylon disagreed, maintaining that the patent supported a broad claim construction and that the accused products infringed each and every claim of the ’589 patent. Specifically, Raylon alleged that the accused devices all literally met the “display being pivotally mounted on said housing” element because they each had “a display that is mounted on the housing and

can be pivoted relative to the viewer's or user's angle of visual orientation." J.A. 4223; J.A. 4912; J.A. 5768. In other words, under Raylon's theory of infringement a display with a fixed-mounted screen meets the 'pivotally mounted on said housing' limitation when the user pivots the device by moving his elbow, wrist, or other joint.

In advance of the *Markman* hearing, both Raylon and defendants proposed constructions of, inter alia, "display being pivotally mounted on said housing," "a printer assembly being mounted in said interior of said housing," and "said housing having an elongated slot for selectively receiving the identification card." Defendants also filed motions for Rule 11 sanctions in each suit. The district court consolidated the three suits for purposes of claim construction, summary judgment, and sanctions.

On December 2, 2010, the district court held a consolidated hearing. The only term construed was "display being pivotally mounted on said housing." Raylon construed the term to mean "an electronic device attached to a housing for the visual presentation of information, the display capable of being moved or pivoted relative to the viewer's perspective." Defendants proposed various constructions, all of which excluded from "pivotally mounted" any displays that are fixed or incapable of pivoting.¹ The district court rejected Raylon's construction, noting that its citation to the specification did not support its overly broad claim construction such that its

¹ Defendant EZ Tag proposed a construction that requires the housing and display to not be in fixed positions. Defendants Casio, Complus, and Fujitsu construed the limitation as requiring the display to be mounted to the housing such that the housing and display are pivotal with respect to each other.

construction “stretch[es] the bounds of reasonableness beyond what I am willing to accept.” J.A. 3681. Accepting defendants’ construction, the district court granted summary judgment in their favor. The court concluded the hearing by denying defendants’ motions for Rule 11 sanctions.

The district court’s holdings were memorialized in later-issued orders. On March 9, 2011, the district court issued an order reflecting its denial of Rule 11 sanctions. In that order, the district court quoted the Fifth Circuit’s objective standard and stated that while “Raylon’s claim construction arguments and infringement theory do stretch the bounds of reasonableness, and the Court rejected Raylon’s positions, they do not cross the line.” J.A. 4. The court then analyzed Raylon’s settlements and damages model to determine whether Raylon filed suit to recover nuisance value settlements or whether the numbers were “indicative of the good faith nature with which the case is brought.” *Id.* It found Raylon’s proffered model “not large for a patent case,” suggesting that Raylon’s “earlier settlements were not so unreasonable as to indicate that Raylon believed its case was weak or frivolous.” *Id.* On this basis, the district court concluded that this was not a situation where “the cost of the litigation is more of a driving force than the merits of the patent-in-suit,” so it denied the motions without considering the merits of the suit. J.A. 6.

On March 23, 2011, the district court issued an order granting summary judgment of non-infringement in favor of defendants. Based on the court’s construction of the “pivotally mounted” term² and the fact that all the ac-

² As a result of the consolidated hearing, discussed above, the district court construed the “display being

cused products have a fixed display screen, the district court held that none of the accused products literally infringe. The district court also found that the accused products' fixed screens do not infringe under the doctrine of equivalents because the fixed screens do not perform substantially the same function in the same way to achieve the same result as a pivotally mounted display, and Raylon's theory would read the "pivotally mounted" limitation out of the claims.

After final judgment was entered on March 23, 2011, defendants filed motions for attorneys' fees and costs pursuant to 35 U.S.C. § 285, 28 U.S.C. § 1927, and the court's inherent powers. In a joint order on October 31, 2011, the district court denied the motions. It found Raylon's suits were not objectively baseless for the same reason it denied Rule 11 sanctions. The court also rejected defendants' arguments that Raylon's conduct in pursuing the baseless claims constituted litigation misconduct. The court similarly denied fees and costs under § 1927. On October 31, 2011, the court entered an amended final judgment. Defendants appeal.

DISCUSSION

On appeal, defendants challenge the district court's denial of Rule 11 sanctions and of attorneys' fees. We address each issue in turn.

A. Rule 11 Sanctions

pivotally mounted on said housing" term as "the display must be mounted on the housing so that the display and housing may pivot with respect to each other." J.A. 7029.

Rule 11 expressly requires that an attorney presenting a pleading, motion, or other paper before the court certify that he has performed “an inquiry reasonable under the circumstances” such that he can verify that (1) “it is not being presented for any improper purpose, such as to harass, cause unnecessary delay, or needlessly increase the cost of litigation,” (2) “the claims . . . are warranted by existing law or by a nonfrivolous argument for extending, modifying, or reversing existing law;” (3) “the factual contentions have evidentiary support or, . . . will likely have evidentiary support after a reasonable opportunity for further investigation or discovery.” Fed. R. Civ. P. 11(b)(1)-(3). As the 1993 advisory committee note explains, this rule “requires litigants to ‘stop-and-think’ before initially making legal or factual contentions.” Fed. R. Civ. P. 11 advisory committee note to 1993 amendments, 149 F.R.D. 401, 584-85. The notes explain that the changes to the rule “emphasize[] the duty of candor by subjecting litigants to potential sanctions for insisting upon a position after it is no longer tenable.” *Id.*

In reviewing a district court’s decision to deny Rule 11 sanctions, we apply the law of the regional circuit. *Eon-Net LP v. Flagstar Bancorp*, 653 F.3d 1314, 1328 (Fed. Cir. 2011). The Fifth Circuit reviews a denial of sanctions for an abuse of discretion. *Whitehead v. Food Max of Miss., Inc.*, 332 F.3d 796, 802 (5th Cir. 2003) (en banc); see *Cooter & Gell v. Hartmarx Corp.*, 496 U.S. 384, 405 (1990). A district court necessarily abused its discretion “if it based its ruling on an erroneous view of the law or on a clearly erroneous assessment of the evidence.” *Whitehead*, 332 F.3d 796 (quoting *Cooter & Gell*, 496 U.S. at 405); *Skidmore Energy, Inc. v. KPMG*, 455 F.3d 564, 566 (5th Cir. 2006) (“A district court abuses its discretion if it imposes sanctions based on (1) an erroneous view of

the law or (2) a clearly erroneous assessment of the evidence.”).

Defendants argue that the denial of Rule 11 sanctions should be reversed because the district court abused its discretion in two regards. They argue that the district court applied the wrong standard—a subjective, rather than objective one—in evaluating Raylon’s conduct. Defendants argue that under the proper standard, Raylon’s claim construction and infringement contentions with regards to the “pivotally mounted” limitation (as well as others not addressed by the district court) were objectively unreasonable. Defendant Symbol also alleges that the district court abused its discretion by failing to consider some of its arguments. Specifically, Symbol argued that Raylon’s construction of a printer in “said housing” to include a printer in any housing, including an auxiliary housing, was frivolous; Symbol also argued that Raylon’s infringement allegations against its products, none of which contain a printer, were frivolous.

We agree with defendants. In the Fifth Circuit, when determining whether there was a Rule 11 violation, “the standard under which an attorney is measured is an objective, not subjective standard of reasonableness under the circumstances.” *Whitehead*, 332 F.3d at 803. The district court abused its discretion by evaluating

Raylon’s conduct under a subjective standard.³ See *FDIC v. Maxxam, Inc.*, 523 F.3d 566, 580-81 (5th Cir. 2008); *Cooter & Gell*, 496 U.S. at 405. Specifically, the court evaluated Raylon’s damages model and early settlements to determine whether it brought its suits in good faith or merely to obtain nuisance value settlements. The court opined that “in some situations, a plaintiff asserting a large damages model while making very low offers in the case may indicate that the plaintiff realizes its case is very weak or even frivolous” and that the amount of damages “may be indicative of the good-faith nature with which the case is brought.” J.A. 4. It found Raylon’s damages model “not large for a patent case” such that “the earlier settlements were not so unreasonable as to indicate that Raylon believed its case was weak or frivolous.” *Id.* Based on these findings as to Raylon’s motives, the district court denied defendants’ motion. In its view, Rule 11 sanctions only apply “[w]here it is clear that a case lacks any credible infringement theory *and* has been brought only to coerce a nuisance value settlement.” J.A. 5 (emphasis added). But, this is not the proper standard. The Fifth Circuit “has been emphatic” that the Rule 11 analysis is a strictly objective inquiry and “expressly rejected any inquiries into the motivation behind a filing.” *Maxxam*, 523 F.3d at 580; *Jenkins v. Methodist Hosp. of Dallas*, 478 F.3d 255, 264 (5th Circuit 2007). Thus, an evaluation of Raylon’s litigation motives—whether it brought suit in good faith or to obtain nuisance value settlements—contradicts Fifth Circuit law and has no place in the Rule 11 analysis. The district court denied

³ The district court mentioned Raylon’s claim construction positions—stating “[w]hile Raylon’s claim construction arguments and infringement theory do stretch the bounds of reasonableness, and the [c]ourt rejected Raylon’s positions, they do not cross that line”—but provided no analysis or explanation for this conclusion.

Rule 11 sanctions through the lens of an erroneous view of the law, and thus abused its discretion. *Skidmore*, 455 F.3d at 566.

Applying the objectively reasonable standard, we agree with defendants that Raylon’s claim construction (and thus infringement contentions) were frivolous. Claim construction is a matter of law, so that an attorney’s proposed claim construction is subject to Rule 11(b)(2)’s requirement that all legal arguments be non-frivolous. *Antonious v. Spalding & Evenflo Cos., Inc.*, 275 F.3d 1066, 1071 (Fed. Cir. 2002). Reasonable minds can differ as to claim construction positions and losing constructions can nevertheless be nonfrivolous. But, there is a threshold below which a claim construction is “so unreasonable that no reasonable litigant could believe it would succeed,” *iLor, LLC v. Google, Inc.*, 631 F.3d 1372, 1378 (Fed. Cir. 2011), and thus warrants Rule 11 sanctions.

Raylon’s claim construction of “display pivotally mounted on said housing” is a prime example of a construction that falls below this threshold. Raylon, throughout the litigation, argued that this term should be construed as requiring a “display being capable of being moved or pivoted *relative to the viewer’s perspective*.” J.A. 1477 (emphasis added). Its construction encompasses any portable device with a display, regardless of how it is mounted to the housing. *See, e.g.*, J.A. 3671 (Raylon’s example of a device not covered by the claim term is “a printer with a fixed display” because a printer cannot be pivoted relative to the user). In support of this broad construction, Raylon relies on a single sentence in the specification. That sentence states: “Even still another object of the present invention is to provide a new identification investigating and ticket issuing system that

permits a police officer to maintain visual contact of a stopped person while investigating whether the person has any warrants or suspended license.” ’589 patent col.3 ll.42-46.

Neither this sentence nor any other intrinsic evidence supports Raylon’s position that the term “pivotally mounted” is relative to the user rather than to the device’s housing. Rather, each and every claim of the ’589 patent requires a “display being pivotally mounted *on said housing*.” ’589 patent col.7 ll.29-31; col.8 ll.55-57; col.9 ll.20-22 (emphasis added). Throughout the specification, the patentee describes the invention as containing a display that “is pivotally mounted on the housing.” *Id.* Abstract; col.1 ll.38-39; col.2 l.11; col.3 ll.29-30; col.5 ll.59-60. A display pivotally mounted on the housing is even identified by the patentee as one of the important features of the invention. *Id.* col.2 ll.14-16. Figure 1, the only schematic of the preferred embodiment, shows a display that is mounted to pivot relative to the housing on which it is attached. Furthermore, throughout the prosecution history, the patentee described the display as “pivotally mounted on said housing.” No other placement of the display relative to the housing is described in the patent or prosecution history. Thus, Raylon’s claim construction—that pivotally mounted only requires the display be pivotable relative to the user—is contrary to all the intrinsic evidence and does not conform to the standard canons of claim construction. J.A. 7025-26; *see Q-Pharma, Inc. v. Andrew Jergens Co.*, 360 F.3d 1295, 1301 (Fed. Cir. 2004); *cf. MarcTec, LLC v. Johnson & Johnson*, 664 F.3d 907, 918 (Fed. Cir. 2012) (finding a claim construction position objectively baseless where “no reasonable application of the principles enunciated in *Phillips* . . . supports its position”). This is a clear instance where no objectively reasonable litigant, relying on the single

sentence in the specification to support its position, would believe its claim construction could succeed; therefore, Raylon's claim construction is frivolous and thus sanctionable under Rule 11(b)(2).⁴

In addition to the “pivotally mounted” limitation, defendants—in particular, Symbol—argued that several other of Raylon's claim constructions were frivolous based on similar reasoning.⁵ Despite the presence of these arguments in defendants' Rule 11 briefs, claim construction briefs, and a motion for judgment on the pleadings, the district court failed to even touch on these terms in its Rule 11 analysis. The district court's failure to consider these arguments was an abuse of discretion. *Copeland v. Wasserstein, Perella & Co.*, 278 F.3d 472, 484-85 (5th Cir. 2002) (“It is well settled that, to conduct our review, we must be able to understand the district court's disposition of the sanctions motion.”); *S. Bravo Sys., Inc. v. Containment Techs. Corp.*, 96 F.3d 1372, 1375 (Fed. Cir. 1996)

⁴ Raylon's infringement contentions were based on its claim construction. Because we find Raylon's claim construction of “pivotally mounted” frivolous, we need not reach whether Raylon's infringement contentions serve as an independent basis for imposing Rule 11 sanctions.

⁵ The limitations at issue were “a printer assembly being mounted in said interior of said housing” and “said housing having an elongated slot for selectively receiving the identification card.” Raylon construed these limitations as covering printer assemblies and elongated slots that were contained in any housing despite the use of “said” housing in the claims. Symbol argued that based on the claims' use of “said housing” and the specification, the claims require the printer assembly and elongated slot to be in the same housing as the other elements of the device.

(“When the requesting party makes a strong showing that Rule 11 violations may have occurred, however, the district court should provide some explanation for disregarding the proffered showing.”); *Refac Int’l Ltd. v. Hitachi, Ltd.*, 921 F.2d 1247, 1257 (Fed. Cir. 1990). Raylon’s construction of “a printer assembly being mounted in said interior of said housing” is, if anything, even more unreasonable than the “pivotally mounted” construction. The claims are clear that the housing has an interior, the display is pivotally mounted “on said housing,” and the printer assembly is mounted “in said interior of said housing.” The specification is completely consistent with the claims, explaining that an “object of the present invention” is to provide a system “which includes a housing that includes an interior.” *Id.* col.3 ll.17-19. The printer assembly, in turn, “is mounted in the interior of the housing.” *Id.* col.3 ll.30-33; *see also* col.1 ll.25-41; col.1 l.66-col.2 l.13; col.5 ll.66-67 (same). The only reasonable construction is that the printer is mounted inside and the display is mounted on the same housing.

Raylon’s attorney argued that claim construction “is kind of [an] arcane subject that gets ordinary lawyers like me in trouble a lot of times.” J.A. 14048. There is nothing arcane about the location of the printer assembly in the claimed invention. Raylon’s position that the printer could be in an entirely different housing from the rest of the components is objectively unreasonable and an independent violation of Rule 11 with respect to Symbol, whose products lack a printer entirely. On remand, the district court should weigh Raylon’s multiple frivolous arguments with respect to Symbol’s products when crafting an appropriate sanction.

When a party’s conduct violates Rule 11(b), the court must impose “an appropriate sanction.” Fed. R. Civ. P.

11(c)(2). Rule 11 sanctions “may be set at a level ‘sufficient to deter repetition of such conduct or comparable conduct by others similarly situated.’” *Clinton v. Jones*, 520 U.S. 681, 710 n.42 (1997) (quoting Fed. R. Civ. P. 11(c)(2)). Determining what sanction to impose is initially a matter within the discretion of the district court. *Judin v. United States*, 110 F.3d 780, 785 (Fed. Cir. 1997). We remand these cases for a determination of an appropriate sanction.

B. Attorneys’ Fees and Costs

Defendants argue that the district court improperly denied attorneys’ fees and costs under 35 U.S.C. § 285, and that these cases qualify as exceptional under the statute. A case is exceptional under § 285 if there has been some inappropriate conduct relating to the matter in litigation. *Brooks Furniture Mfg., Inc. v. Dutailier Int’l, Inc.*, 393 F.3d 1378, 1381 (Fed. Cir. 2005). Absent litigation misconduct or misconduct in securing the patent, a case is exceptional under § 285 if “(1) the litigation is brought in subjective bad faith, and (2) the litigation is objectively baseless.” *Id.* Similar to the evaluation under Rule 11, for litigation to be objectively baseless, the allegations “must be such that no reasonable litigant could reasonably expect success on the merits.” *Dominant Semiconductors Sdn. Bhd. v. Osram Gmbh*, 524 F.3d 1254, 1260 (Fed. Cir. 2008). The district court found that there was no litigation misconduct. In evaluating whether the cases were otherwise exceptional, the court relied exclusively on its Rule 11 order to find that the litigation was not “objectively baseless.” Since we reverse the district court’s holding with regards to a Rule 11 violation, the district court can no longer rely on its Rule 11 analysis to find the objectively baseless prong not met. We remand to the district court to reconsider, in light of

our decision, whether these cases are exceptional under § 285.⁶ In doing so, the court should consider all of Raylon's conduct, including its assertions with regard to limitations other than "pivotaly mounted," as raised by defendant Symbol.

CONCLUSION

The district court abused its discretion in denying defendants' Rule 11 motions. We reverse the district court's holding that there was no Rule 11 violation and remand to the district court to determine, in the first instance, a proper sanction. Because the court's evaluation of § 285 relied on its Rule 11 analysis, we vacate the district court's denial of attorneys' fees and costs, and remand for the court to reconsider defendants' motions in light of our decision.

AFFIRMED-IN-PART, VACATED-IN-PART, AND REMANDED

⁶ We leave the district court's denial of attorneys' fees and costs under 28 U.S.C. § 1927 undisturbed. Establishing attorney misconduct under § 1927 implicates a higher level of culpability than Rule 11, and defendants have not established that Raylon's misconduct rises to the level required by § 1927. *See Bryant v. Military Dep't of Miss.*, 597 F.3d 678, 694 (5th Cir. 2010).

**United States Court of Appeals
for the Federal Circuit**

RAYLON, LLC,
Plaintiff-Appellee,

v.

COMPLUS DATA INNOVATIONS, INC.,
Defendant-Appellant,

AND

**CASIO AMERICA, INC. AND CASIO COMPUTER
CO., LTD.,**
Defendants-Appellants,

AND

SYMBOL TECHNOLOGIES, INC.,
Defendant-Appellant,

AND

**ADVANCED PUBLIC SAFETY, INC., TRIPOD DATA
SYSTEMS, ZEBRA
TECHNOLOGIES CORPORATION, EZ TAG
CORPORATION, FUJITSU AMERICA,
INC. AND FUJITSU JAPAN LTD.,**
Defendants.

2011-1355, -1356, -1357, -1358, -1359

Appeals from the United States District Court for the Eastern District of Texas in No. 09-CV-0355, 09-CV-0356, 09-CV-0357, Judge Leonard Davis.

REYNA, *Circuit Judge*, concurring.

I concur with the majority opinion and the result reached. I write separately to make clear that when a court finds a Rule 11 sanction based on conduct involving the allegation and pursuit of patent infringement claims that have been found objectively unreasonable, the court is compelled, if so moved by a party, to undertake a detailed and thorough § 285 inquiry and analysis. I deviate slightly from my colleagues in the majority in that, given the record in this case, I would reverse and declare this an exceptional case and limit the remand to determination of appropriate sanctions.

I. LEGAL LANDSCAPE

In three separate suits that were later consolidated, Raylon, LLC (“Raylon”) alleged that numerous defendants infringed U.S. Patent No. 6,655,589 (“the ’589 patent”). At the conclusion of a hearing addressing claim construction, summary judgment, and motions for sanctions, eight defendants, including appellants Complus Data Innovations, Inc., Casio America, Inc. and Casio Computer Co., Ltd., (collectively “Casio”), and Symbol Technologies, Inc. (“Symbol”) (collectively, “defendants”), prevailed on their respective motions for summary judgment of non-infringement.

Casio argued a Rule 11 motion on behalf of defendants. Casio asserted that the accused devices were missing certain limitations claimed in the ’589 patent. Casio stressed that it gave Raylon advance notice that its

infringement allegations were without merit, further, were objectively unreasonable.

Symbol joined Casio's argument regarding the pivotal mounting of the display, but also moved for sanctions under Rule 11 because Raylon had disregarded claim language requiring that a printer be inside of the housing to which the pivotally mounted display is attached.

In the face of defendants' strongly argued assertions of objective unreasonableness, Raylon maintained that its allegations were objectively reasonable, including on grounds that it relied on expert advice of patent attorneys who conducted a pre-suit investigation. At the claim construction hearing, instead of advancing arguments based on the plain language of its asserted claims, Raylon offered that its claim construction proposals were premised on the "rather unusual interpretations that are sometimes put on claim terms by the Federal Circuit and practitioners." J.A. 14049.

The district court denied the motions for sanctions. At the hearing, and later in a written order, the district court determined that Raylon's positions "stretched the bounds of reasonableness," but were not "objectively frivolous." J.A. 4; J.A. 14052. Rather than analyzing the reasonableness of Raylon's proposed claim constructions in the context of the intrinsic record, the district court supported its ruling by weighing the reasonableness of Raylon's settlement agreements against a damages model. *See* Majority Op. 8 (citing J.A. 6); J.A. 14053–14054. The district court's written order concluded that Rule 11 sanctions would only be warranted "[w]here it is clear that a case lacks any credible infringement theory *and* has been brought only to coerce a nuisance value settlement." J.A. 5 (emphasis added).

Prevailing parties Casio, Complus, and Symbol moved for an award of fees and a declaration that this case is exceptional pursuant to 35 U.S.C. § 285. The district court tied its § 285 objective inquiry to the earlier Rule 11 sanctions inquiry and declined to find the case exceptional. The district court did not provide detailed findings regarding whether the litigation was objectively baseless or whether Raylon brought the litigation in subjective bad faith. The ruling generally concluded that Raylon's pivotally mounted display positions were not objectively baseless and there was no litigation misconduct that warranted an inference of bad faith. J.A. 13.

II. DISTINCT RULE 11 AND § 285 INQUIRIES

Rule 11 of the Federal Rules of Civil Procedure and 35 U.S.C. § 285 of the Patent Act offer courts distinct, yet overlapping, rationales for awarding an injured party relief. In asking whether a party violated Rule 11, courts in the Fifth Circuit look only to "objectively ascertainable circumstances." *FDIC v. Maxxam, Inc.*, 523 F.3d 566, 586 (5th Cir. 2008). By contrast, our § 285 precedent asks (1) whether the litigation is brought in subjective bad faith, and (2) whether the litigation is objectively baseless. *Brooks Furniture Mfg., Inc. v. Dutailier Int'l, Inc.*, 393 F.3d 1378, 1381 (Fed. Cir. 2005).

Rule 11 directs attorneys to focus on their obligations and responsibilities as officers of the court in making representations, while also operating as an enforcement mechanism to correct any "unusual circumstances" where a party "pursued an illegitimate purpose to increase costs or to harass a party regardless of the weight of that purpose in filing suit." *Maxxam*, 523 F.3d at 586 (explaining that Rule 11 reaches those pleadings which constitute an abuse of legal purpose by discouraging dilatory or abusive tactics); *see also Jenkins v. Methodist Hosp. of*

Dallas, Inc., 478 F.3d 255, 265 (5th Cir. 2007) (“As stated by the Advisory Committee Note to Rule 11, a lawyer is required to ‘stop-and-think’ before . . . making legal or factual contentions.”) (quoting Advisory Committee Notes on FED. R. CIV. P. 11 (1993 Amendments)). Sanctionable Rule 11 conduct is distinguishable from a judgment on the merits because Rule 11 addresses the collateral issue of “whether the attorney has abused the judicial process, and, if so, what sanction would be appropriate.” *Cooter & Gell v. Hartmarx Corp.*, 496 U.S. 384, 396 (1990).

Section 285 was enacted to address a patent-specific policy rationale, awarding fees in “exceptional cases” in which sanctions were necessary to deter the “improper bringing of clearly unwarranted suits.” *Automated Bus. Cos., v. NEC Am., Inc.*, 202 F.3d 1353, 1354 (Fed. Cir. 2000) (quoting *Mathis v. Spears*, 857 F.2d 749, 753–54 (Fed. Cir. 1988)). The purpose of the statute has been described by this court as compensation to the prevailing party for its monetary outlays in the prosecution or defense of the suit. *See Cent. Soya Co. v. Geo. A. Hormel & Co.*, 723 F.2d 1573, 1578 (Fed. Cir. 1983). Such a purpose is distinguishable from Rule 11, which addresses conduct in general, because § 285 recognizes the particular strain that meritless patent litigation bears on judicial and party resources. *Eon-Net LP v. Flagstar Bancorp*, 653 F.3d 1314, 1327 (Fed. Cir. 2011) (noting the burden of unnecessarily requiring a “district court to engage in excessive claim construction before it is able to see the lack of merit of the patentee’s infringement allegations”); *Mathis*, 857 F.2d at 758 (explaining that Congress codified § 285 to make a prevailing defendant “whole” following a gross injustice).

In non-patent contexts, a litigant is sometimes sanctioned for misleading the court, *e.g.*, *Precision Specialty*

Metals, Inc. v. U.S., 315 F.3d 1346, 1357 (Fed. Cir. 2003), or for exhibiting sloppiness during the course of the proceedings, *Spiller v. Ella Smithers Geriatric Ctr.*, 919 F.2d 339, 347 (5th Cir. 1990) (“slipshod and unprofessional work”). But in patent cases invoking Rule 11, courts are often asked to weigh whether the substantive allegations are so weak that they are not grounded in fact and legally tenable. *See, e.g., View Eng’g, Inc. v. Robotic Vision Sys., Inc.*, 208 F.3d 981, 986 (Fed. Cir. 2000).

Here, notwithstanding whether sanctions are issued pursuant to Rule 11, § 285, or both, the offending conduct is intertwined with governing patent law. I believe that if the circumstances in a patent case result in finding that Rule 11 has been violated on grounds related to substantive positions taken or advanced, then the district court must also, when so moved by the parties, engage in a comprehensive § 285 inquiry. In my view, a § 285 inquiry is compelling where the case progresses beyond the pleading stages and a party’s unwillingness to abide by precedent controlling claim construction leads to escalation of avoidable costs.

III. RECORD INFERENCES OF BAD FAITH

Having determined that the challenged litigation is objectively meritless,¹ a court may examine the litigant’s subjective motivation. *Prof’l Real Estate Investors, Inc. v.*

¹ This court recently held that objective baselessness is a question of law based on underlying mixed question of law and fact. *Highmark, Inc. v. Allcare Health Mgmt. Sys., Inc.*, 687 F.3d 1300, 1309 (Fed. Cir. 2012). The *Highmark* decision did not issue until after the district court denied the § 285 motion. Because I find Raylon’s claim construction and infringement positions meritless, the objective analysis would compel the same result regardless of whether we reviewed *de novo* or for clear error.

Columbia Pictures Indus., Inc., 508 U.S. 49, 60–61 (1993). There is a presumption that the assertion of infringement is made in good faith, *Brooks Furniture*, 393 F.3d at 1382 (internal citation omitted), but even so, we examine the record with care to determine, among other things, whether a party demonstrated good faith during the claim construction process. See *Eon-Net*, 653 F.3d at 1325. If the record indicates by clear and convincing evidence that a patentee is manifestly unreasonable in assessing and pressing its infringement allegations, then a court may infer that the claims were brought in bad faith. *Eltech Sys. Corp. v. PPG Indus., Inc.*, 903 F.2d 805, 810–11 (Fed. Cir. 1990).

Our cases have not established a precise definition for “bad faith” in the exceptional case context. We recognize the enactment of § 285 as a “bad faith equitable exception” to the American Rule on awarding fees to an alleged infringer, *Mathis*, 857 F.2d at 758 (internal citation omitted), and discuss “bad faith” as closely aligned with “a finding of unfairness”:

[T]he payment of attorney’s fees for the victor is not to be regarded as a penalty for failure to win a patent infringement suit. The exercise of discretion in favor of such an allowance should be bottomed upon **a finding of unfairness or bad faith** in the conduct of the losing party, or some other **equitable consideration** of similar force, which makes it **grossly unjust** that the winner of the particular law suit be left to bear the burden of his own counsel fees which prevailing litigants normally bear.

Rohm & Haas Co. v. Crystal Chemical Co., 736 F.2d 688, 691 (Fed. Cir. 1984) (emphases added) (discussing 1952

Patent Act) (quoting *Park-in Theatres, Inc. v. Perkins*, 190 F.2d 137, 142 (9th Cir. 1951)). Against this backdrop, I interpret “bad faith” as synonymous with a patent holder’s unreasonable continued pursuit of an infringement claim that has been demonstrably shown to be based on “wrongful intent, recklessness, or gross negligence.” *Phonometrics, Inc. v. Westin Hotel Co.*, 350 F.3d 1242, 1246 (Fed. Cir. 2003) (quoting *Eltech*, 903 F.2d at 811).

As I have noted, I agree with and join the majority’s strong analysis and result on Rule 11 sanctions. But, unlike the majority, I believe that the district court, in the first instance, should have fully explored the existence of an inference of bad faith.² These consolidated cases provide fertile grounds for a determination that Raylon’s pursuit of objectively unreasonable allegations compelled the conduct of an exceptional case inquiry. While reasonable minds can—and often do—differ as to the proper construction of a given claim term, it is unreasonable minds that go to extraordinary lengths to conjure and advance through various stages of a legal proceeding unsupported arguments that are also inconsistent with established precedent in order to accuse non-infringing devices. Here, specific circumstances which, if taken in the aggregate, potentially give rise to an inference that

² The district court limited its scant subjective intent analysis to general statements that there was no material misconduct because of a low probability of the case having been brought to force a settlement. J.A. 13. These general statements are incomplete following the acknowledgement that Raylon’s claim construction positions “stretched the bounds of reasonableness.” J.A. 4. Recognition of the objectively weak contentions was basis enough to further inquire as to bad faith.

Raylon demonstrated an awareness that its allegations lacked support.

A. EARLY NOTICE

Here the likelihood of success on infringement could have been projected simply by examining the accused devices and comparing those features element-by-element and claim-by-claim with the disclosures in the '589 patent. Rather than acknowledge that its claims could not survive, Raylon built its case on positions that misapply Federal Circuit precedent.³ The record establishes that Raylon was not unaware as to knowledge of its substantive shortcomings because it was faced with early motions for summary judgment, a motion for judgment on the pleadings, and motions for sanctions that identified the flaws in the infringement theories.

Indeed, Casio memorialized its concerns by writing to Raylon early in the case regarding the merits of its allegations, but it appears that Raylon took no curative measures and proceeded through claim construction undeterred. J.A. 3139 (“As we have repeatedly told you since day one, these infringement allegations are violations of Rule 11.”); J.A. 3141–43; J.A. 3145–46; J.A. 3153–54 (counsel correspondence discussing perceived violations of Rule 11). This early notice at least suggests that Raylon had a duty to “stop and think,” and to investigate whether its positions were objectively baseless, but it opted to ignore grappling with the incongruence raised by visual comparison of the accused devices with the plain language of the claims.

³ Although Raylon noted at the claim construction hearing that it considers Federal Circuit teachings “somewhat unusual,” it is still bound to adhere to those guidelines—even when such rulings do not suit its litigation strategy. *See* J.A. 14049.

B. “PIVOTALLY MOUNTED DISPLAY”

Raylon contended that the flatly fixed displays of the accused devices could meet the “pivotally mounted display” limitation because a person could move the entire device while it was held in the user’s hand. Yet, as the majority well clarifies, this position is inconsistent with the intrinsic disclosures and Raylon cannot rely on a single, inapposite sentence in the specification to redefine the meaning of the claim. Majority Op. 13-14. As shown in Figure 1, the display was mounted on the housing in such a manner that it could be pivoted up or down with no movement of the housing. Illustrations of the patent figures next to the accused devices emphasize the objective unreasonableness of Raylon’s infringement allegations.

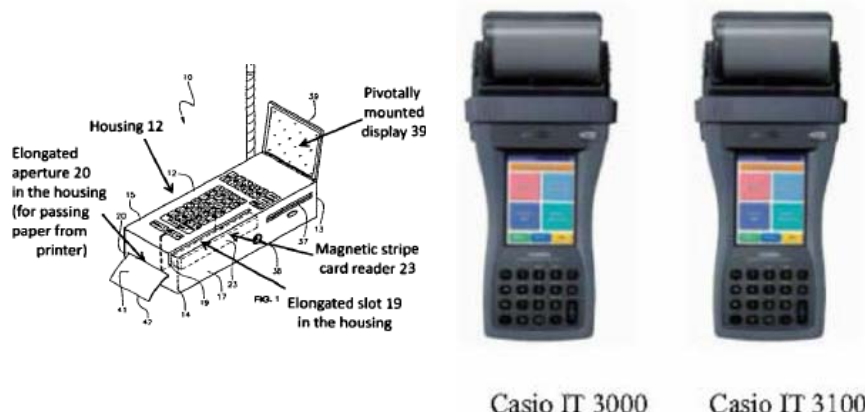

Figure 1 in '589 patent
(display pivotally mounted to housing)

Casio Accused Devices
(flat display fixed to housing)

The '589 patent specification teaches that the pivotally mounted display is attached to the housing and as a result the housing be made able to pivot up or down. '589 patent col.5 ll.58-61 (depicted in Figure 1). By contrast, it is readily apparent that the accused devices are fixed in a flat position and lack a display that is not, nor is it capable of, being pivotally mounted on the housing. Given the clear meaning of the claim elements, no objectively reasonable litigant would believe it could succeed by linking the “pivot” to the up and down movement of the user’s arm.⁴

C. “INTERIOR PRINTER ASSEMBLY”

Raylon also asserted all seventeen claims in the '589 patent against printerless Symbol devices by contending that an *external* printer attached to a separate housing would satisfy the limitation requiring the printer assembly be mounted in the *interior* of the housing. To maintain its allegations, Raylon disregarded the meaning of the word “said” as presented in the claims: “a printer assembly being mounted in **said** interior of **said** housing for printing a ticket.” '589 patent col.7 ll.32-33 (claim 1) (emphases added). As our cases require, “said” refers back to an earlier use of that term in the claim. *Intamin, Ltd. v. Magnetar Tech. Corp.*, 483 F.3d 1328, 1333 (Fed. Cir. 2007); *Bell Commc’n Research, Inc. v. Vitalink Commc’n Corp.*, 55 F.3d 615, 621 (Fed. Cir. 1995). Here, “said housing” is referring back to an earlier use of “housing” that describes “an interior,” “an elongated slot,” and “an elongated aperture.” '589 patent col.7 ll.17-20. De-

⁴ As pointed out in the briefing, Raylon misrepresented the claim language—by substituting “pivotable” in place of the “pivotally mounted” limitation—and proceeded to claim construction by relying on an untenable position that was refuted by the '589 patent specification. See J.A. 12239–40; 12247; 12253; 12273–74.

spite the known requirements, Raylon glosses over the well-defined relationship between the interior printer, the housing, and remaining claim elements.

The disconnect between the accused devices and the claim language should have been apparent, but we have no indication as to whether Raylon's expert's conducted a visual examination of the Symbol devices and the stand alone printers. *See* J.A. 3975–82; 3991–4008. Again, the above figures clearly show that in the preferred embodiment of the '589 patent, a printer is housed within the device. Raylon argues that attaching a stand alone printer to the Symbol device satisfies the claim that the printer be located in the housing of the device.

The absence of analysis regarding the Symbol devices immediately raises doubt as to the credibility of Raylon's assertions. For example, in responses to defendants' motions for summary judgment, counsel for Raylon made only the limited statement that accused Symbol devices were analyzed by Raylon's patent expert and that Symbol was provided claim charts that "consisted of a good faith, informed comparison of the claims of a patent against the accused subject matter." J.A. 3972, ¶ 9; *see also id.* at 3969–71, ¶¶ 1–5. Raylon did not supplement the comparison with an explanation as to what the expert was relying upon or how the Symbol devices might infringe. In the end, Raylon never conceded the unavoidable reality that Symbol models did not infringe. Notably, Raylon continued to defend the reasonableness of its allegations on appeal, including during the oral argument before this court. Oral Argument, *available at* <http://www.cafc.uscourts.gov/oral-argument-recordings/all/raylon.html>.

D. UNDUE RELIANCE ON EXPERT DECLARATIONS

Instead of focusing on why its pre-suit investigation was a reasonable application of *Phillips*, Raylon argues that its allegations were made in good faith because it was informed by pre-suit advice it received from a patent practitioner it considered an expert. Applicable law, however, clearly states that a patent practitioner's statements regarding the meaning of claim terms are entitled to no weight. *Symantec Corp. v. Computer Assocs. Intern., Inc.*, 522 F.3d 1279, 1289 n.3 (Fed. Cir. 2008) (citing *Sinorgchem Co., Shandong v. Int'l Trade Comm'n*, 511 F.3d 1132, 1137 n. 3 (Fed. Cir. 2007)). Similarly, patent practitioners are unqualified to opine on the issue of infringement. *See Sundance, Inc. v. DeMonte Fabricating Ltd.*, 550 F.3d 1356, 1362.

The majority has ascertained that Rule 11 sanctions were necessary because Raylon did not follow standard canons of claim construction and its arguments were not reasonably supported by the intrinsic record. To date there have been no findings as to the adequacy of the pre-suit investigation and whether it was conducted in a manner intended to ignore or overlook the weakness of the infringement allegations. The circumstances surrounding the pre-suit investigation, including whether plaintiff demonstrated diligence prior to filings its suits, might be accounted for on remand when determining whether Raylon's actions support an inference of bad faith.

For the post-Complaint analysis, Raylon defers to its technical expert, Dr. Sharp. Review of Dr. Sharp's declaration reveals no significant effort to explain why Raylon's interpretation of the pivotally mounted display limitation

is the best understanding of the feature in light of the patent disclosures. *See* J.A. 3991–4008. The declaration simply states Dr. Sharp’s tacit approval of Raylon’s expansive positions through cursory conclusions indicating that there is “no restriction” that would stand in the way of Raylon’s effort to link the claim language to the perspective of the viewer. J.A. 4001–02. Dr. Sharp made no reasonable attempt to create a nexus between the asserted patent and the accused devices. Raylon’s heavy and continued reliance on an uninformative declaration calls into question whether the statements were predicated in good faith.

Raylon’s elevation of extrinsic declarations again ignores Federal Circuit precedent, which, at minimum, requires that structural discrepancies that lie at the basis of an infringement allegation be explained according to the intrinsic evidence. *Bell & Howell Document Mgmt. Prod. Co. v. Altek Sys.*, 132 F.3d 701, 706 (Fed. Cir. 1997) (“Patents should be interpreted on the basis of their intrinsic record, not on the testimony of such after-the-fact ‘experts’ that played no part in the creation and prosecution of the patent.”) (citing *Southwall Tech., Inc. v. Cardinal IG Co.*, 54 F.3d 1570, 1578 (Fed. Cir. 1995)). I submit that an inference of bad faith may arise where expert conclusions are steadfastly relied upon to “inject a new meaning into terms that is inconsistent with what the inventor set forth in his or her patent and communicated, first to the patent examiner and ultimately to the public.” *Bell & Howell*, 132 F.3d at 706.

IV. CONCLUSION

When a court finds a Rule 11 sanction based on conduct involving the allegation and pursuit of patent infringement claims that have been found objectively unreasonable, the court is compelled, if so moved by a

party, to undertake a detailed and thorough § 285 inquiry and analysis. I concur with the majority and would reverse and declare this an exceptional case and limit the remand to determination of appropriate sanctions.