

NOTE: This disposition is nonprecedential.

**United States Court of Appeals  
for the Federal Circuit**

---

**MALICO, INC.,**  
*Plaintiff-Appellant,*

v.

**COOLER MASTER USA INC., AND  
LSI LOGIC CORPORATION,**  
*Defendants-Appellees.*

---

2013-1680

---

Appeal from the United States District Court for the Northern District of California in No. 3:11-cv-04537-RS, Magistrate Judge Richard Seeborg.

---

Decided: November 17, 2014

---

JOHN WHITAKER, Whitaker Law Group, of Seattle, Washington, argued for plaintiff-appellant. With him on the brief was PHILIP P. MANN, Mann Law Group, of Seattle, Washington.

KAREN I. BOYD, Turner Boyd LLP, of Redwood City, California, argued for defendants-appellees. Of counsel was HEATHER LYNN-THOMPSON POTTS.

---

Before MOORE, REYNA, and CHEN, *Circuit Judges*.

CHEN, *Circuit Judge*.

Malico, Inc. (Malico) appeals from the United States District Court for the Northern District of California's grant of summary judgment of obviousness as to claims 1 and 2 of its patent, U.S. Patent No. 6,476,484 ('484 patent). See *Malico, Inc. v. Cooler Master USA, Inc.*, No. C11-4537 RS, 2013 WL 4482503 (N.D. Cal. Aug. 20, 2013). Malico also appeals the district court's grant of summary judgment limiting the time period for which Malico may recover damages. Although we agree with the district court's damages decision, the district court failed to make adequate findings to support its obviousness determination. Thus, for the reasons set forth below, we affirm the district court's judgment limiting damages and vacate the judgment of invalidity.

## BACKGROUND

### I

Malico owns the '484 patent, entitled "Heat Sink Dissipat[e]r for Adapting to Thickness Change of a Combination of a CPU and a CPU Carrier." Heat sink dissipaters are used to cool electronic components by dissipating heat generated by the component into the surrounding air. The heat sink dissipater recited in the claims of the '484 patent includes a heat dissipater and a retaining device for securing the heat dissipater to an electronic component, for example a CPU assembly.

According to the patent, prior art heat dissipaters were built to accommodate a CPU assembly with a specific thickness. If a user later wished to incorporate a CPU assembly having a different thickness, the user would need to create or purchase a different retaining device to accommodate this change in thickness. To avoid this cost, the invention of the '484 patent accommodates CPU

assemblies having different thicknesses by placing pads at particular positions on the top surface of the heat dissipater. For one size of CPU assembly, the retaining device directly contacts the heat dissipater's top surface. But for the retaining device to still engage the dissipater's top surface when a thinner CPU assembly is used, the retaining device is rotated 90° to allow the device to directly contact the pads that are positioned on the dissipater's top surface. For example, claim 1 recites:

1. A heat sink dissipater, comprising:

a retaining device having a pair of positioning columns formed on first two opposite sides, a pair of retaining edges formed on second two opposite sides, and a plurality of resilient legs extending inwards from said first or second two opposite sides, said retaining edges each being formed with a barb and said resilient legs each having a bent;

a heat dissipater having a plurality of fins formed on a top surface and a plurality of a [sic] gaps between said fins, said resilient legs failing into said gaps when said retaining device is positioned on said heat dissipater in a first orientation or a second orientation orthogonal to said first orientation; and

*plurality of pads formed between fins on said top surface of said heat dissipater;*

*wherein the bent of each resilient leg is placed on a pad when said retaining device is positioned on said heat dissipater in said first orientation, and each resilient leg is placed directly on said top surface when*

*said retaining device is positioned on said heat dissipater in said second orientation.*

'484 patent, 3:19–4:8 (claim 1) (emphases added).

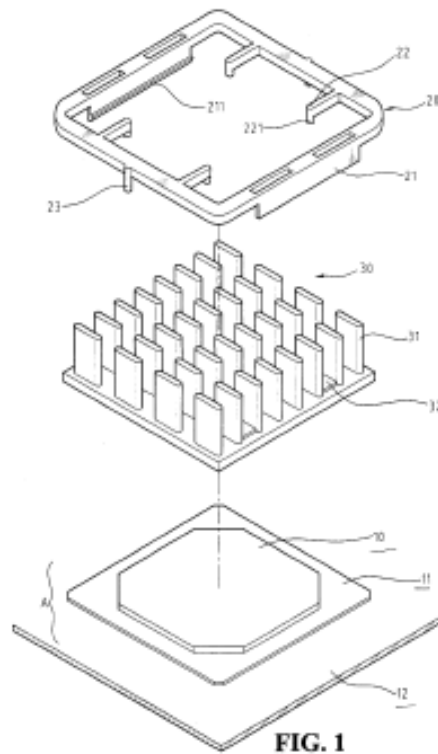

**FIG. 1**

As shown in Figure 1, the retaining device can be oriented such that the “resilient legs [22] having a bent [221]” engage the base of the heat dissipater 30, to secure the heat dissipater to the CPU assembly 10.

Claim 1 further recites that the same retaining device can be rotated 90°, as shown in Figure 2, such that the legs 221 now engage the “pads” 32 located between the fins 31 of the heat dissipater 30.

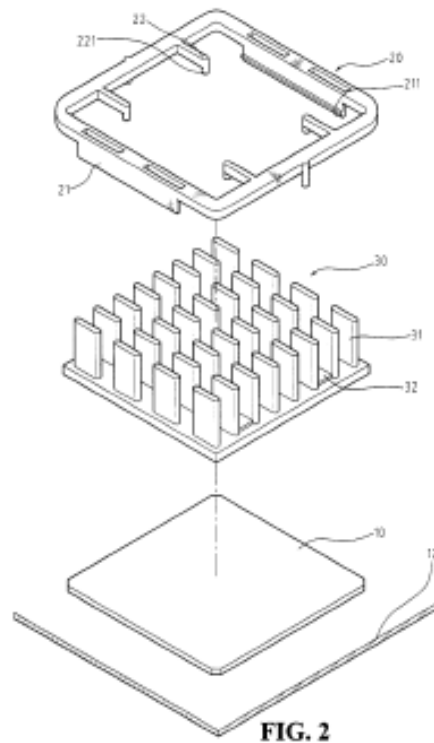

FIG. 2

Claim 2 differs from claim 1 solely by omitting the use of “pads” and, instead, using “recesses” in the top surface of the heat dissipater. *See* '484 patent, 4:9–31 (claim 2) (substituting “plurality of recesses” for “plurality of pads”). To accommodate a thicker CPU assembly, the retaining device is oriented such that the legs rest in the recesses. Alternatively, to accommodate a thinner CPU assembly, the retaining device is oriented in a manner that allows the legs to rest on the top surface of the heat dissipater, rather than in the recesses.

## II

Malico makes and distributes heat sink dissipater products embodying the claims of its '484 patent. Rather than mark these products with the '484 patent number, Malico marked its products with “Int. Pat. XXXX.” J.A. 1068.

Cooler Master USA Inc. (Cooler Master) imported allegedly infringing heat sink dissipaters and sold them to LSI Logic Corporation (LSI). LSI then incorporated the heat sink dissipaters into the larger computer components that LSI assembles and sells.

Malico first claimed infringement of the '484 patent in a letter to LSI on or before March 17, 2008. Malico later filed an action claiming infringement of the '484 patent against Cooler Master on May 26, 2009, in the Western District of Washington, which was ultimately dismissed for lack of personal jurisdiction. In response, Malico initiated the underlying action against Cooler Master and LSI (collectively, Appellees), again asserting infringement of the '484 patent.

In the underlying action, Appellees filed a motion for summary judgment limiting damages and a motion for summary judgment of invalidity.<sup>1</sup> On damages, the district court concluded that Malico could not recover any damages from Cooler Master because Cooler Master received actual notice of infringement of the '484 patent *after* the date of Cooler Master's last sale of the accused device. Similarly, the district court concluded that Malico could recover damages from LSI only for the period between giving LSI actual notice on March 17, 2008, and the date of the last allegedly infringing activity. Finally, the district court granted Appellees' motion for summary judgment of invalidity, finding the two claims of the '484 patent obvious. Malico filed a timely notice of appeal from the district court's summary judgment on damages and invalidity. We have jurisdiction under 28 U.S.C. § 1295(a)(1).

---

<sup>1</sup> Malico also filed a motion for summary judgment of infringement, but the district court denied that motion because Malico provided insufficient evidence to establish infringement. Malico does not appeal that decision.

## DISCUSSION

We review the grant of summary judgment under the law of the regional circuit. *Charles Mach. Works, Inc. v. Vermeer Mfg. Co.*, 723 F.3d 1376, 1378 (Fed. Cir. 2013). The Ninth Circuit reviews the grant or denial of summary judgment *de novo*. *Van Asdale v. Int'l Games Tech.*, 577 F.3d 989, 994 (9th Cir. 2009). Summary judgment is appropriate when “there is no genuine dispute as to any material fact and the movant is entitled to judgment as a matter of law.” Fed. R. Civ. P. 56(a). “When the party moving for summary judgment would bear the burden of proof at trial, . . . [it] has the initial burden of establishing the absence of a genuine issue of fact on each issue material to its case.” *C.A.R. Transp. Brokerage Co. v. Darden Rests., Inc.*, 213 F.3d 474, 480 (9th Cir. 2000) (citation omitted). If the moving party fails to meet its initial burden, summary judgment must be denied and the court need not consider the nonmoving party’s evidence. *Celotex Corp. v. Catrett*, 477 U.S. 317, 332 (1986).

## I. Damages

The amount of damages that a patentee may recover is limited to those acts of infringement that occurred after the patentee gave the alleged infringer “notice of infringement.” 35 U.S.C. § 287(a). A patentee may use constructive notice by marking its patented article with the patent number. *Id.* Where a patentee fails to mark its patented product, however, § 287(a) requires actual notice: “no damages shall be recovered by the patentee in any action for infringement, except on proof that the infringer was notified of the infringement and continued to infringe thereafter, in which event damages may be recovered *only for infringement occurring after such notice.*” *Id.* (emphasis added).

Appellees moved for summary judgment limiting the damages that Malico may recover for infringement that occurred between the dates on which Cooler Master and

LSI, respectively, received actual notice and when the allegedly infringing activity ceased.<sup>2</sup> No party disputes the date on which Cooler Master and LSI, respectively, received notice of Malico's infringement claims. LSI received actual notice by March 17, 2008, through the letter from Malico. Cooler Master, on the other hand, was unaware of Malico's infringement claims until May 26, 2009, when Malico filed its infringement lawsuit against Cooler Master in the Western District of Washington. Appellees produced evidence that their infringing activity ceased in March 2009—one year after LSI received notice and two months *before* Cooler Master received notice of Malico's infringement beliefs. Thus, the district court concluded that Malico could not recover damages from Cooler Master whatsoever and that Malico could recover damages from LSI, but only for acts of infringement that occurred between March 17, 2008, and March 2009.

On appeal, Malico disputes the district court's determination that Appellees' infringement ceased in March 2009. Specifically, Malico contends that the district court failed to consider Malico's evidence that Appellees continued infringing beyond 2009, and, as a result, erroneously characterized Appellees' evidence as undisputed. Malico also argues that even though its motion to compel was denied as untimely, the district court should have nevertheless considered the documentary evidence that Malico attached to that motion. However, Malico fails to recognize that the district court declined to consider this "evidence" only after determining that the evidence attached to Malico's opposition to Appellees' motion for summary judgment limiting damages was inadmissible and that the motion to compel was untimely.

---

<sup>2</sup> No party disputes that Malico's products were not marked with the '484 patent and constructive notice of infringement therefore is not at issue.



Malico first asserts that the evidence attached to its opposition of Appellees' motion demonstrated that Appellees continued to sell the accused products beyond March 2009. Contrary to Malico's assertions, the district court did not "ignore" this evidence. Instead, the district court excluded that evidence because Malico failed to produce these documents during discovery. *See* Fed. R. Civ. P. 37(c)(1) ("If a party fails to provide information . . . as required by Rule 26(a) or (e), the party is not allowed to use that information or witness to supply evidence on a motion, at a hearing, or at a trial.").

Malico also contends that the evidence attached to its motion to compel also showed Appellees' continuing infringing activity and that the district court erroneously disregarded this evidence when ruling on Appellees' motion for summary judgment. Malico's motion to compel was filed months after the close of discovery and was denied as untimely. Moreover, if Malico intended for the district court to consider that evidence in connection with Malico's opposition to Appellees' motion for summary judgment, it should have attached that evidence to the opposition. Because Malico did not do so, the district court did not abuse its discretion when it declined to consider that evidence.

Malico has not sought review of these evidentiary rulings. Consequently, there is no admissible evidence on the record that controverts the district court's finding that the last infringing sales took place in March 2009. No genuine issues of material fact remain and, thus, the district court correctly granted Appellees' motion for summary judgment limiting damages.

## II. Invalidity

Section 103 forbids issuance of a patent when "the differences between the subject matter sought to be patented and the prior art are such that the subject matter as a whole would have been obvious at the time the invention

was made to a person having ordinary skill in the art.” 35 U.S.C. § 103(a). Because issued patents enjoy a presumption of validity, a party moving for summary judgment of invalidity must “submit such clear and convincing evidence of facts underlying invalidity that no reasonable jury could find otherwise.” *TriMed, Inc. v. Stryker Corp.*, 608 F.3d 1333, 1340 (Fed. Cir. 2010) (internal quotation marks omitted).

Obviousness is a question of law based on underlying factual findings. *Honeywell Int’l, Inc. v. United States*, 609 F.3d 1292, 1297 (Fed. Cir. 2010). Any obviousness determination requires an assessment of (1) the “level of ordinary skill in the pertinent art,” (2) the “scope and content of the prior art,” (3) the “differences between the prior art and the claims at issue,” and (4) “secondary considerations” of non-obviousness such as “commercial success, long-felt but unsolved needs, failure of others, etc.” *KSR Int’l Co. v. Teleflex Inc.*, 550 U.S. 398, 406 (2007) (quoting *Graham v. John Deere Co.*, 383 U.S. 1, 17–18 (1966)). A claimed invention may be obvious even when the prior art does not teach each claim limitation, so long as the record contains some reason that would cause one of skill in the art to modify the prior art to obtain the claimed invention. *Beckson Marine, Inc. v. NFM, Inc.*, 292 F.3d 718, 728 (Fed. Cir. 2002). However, although an analysis of the teaching, suggestion, or motivation to combine elements from different prior art references is helpful, we must always be mindful that the obviousness inquiry requires an “expansive and flexible approach.” *Kinetic Concepts, Inc. v. Smith & Nephew, Inc.*, 688 F.3d 1342, 1360 (Fed. Cir. 2012) (citing *KSR*, 550 U.S. at 415, 419). Importantly, this Court has repeatedly explained that district courts must consider all of the *Graham* factors prior to reaching a conclusion that a patent is invalid as obvious. *See, e.g., id.*

The district court found both claims of the '484 patent obvious in light of U.S. Patent No. 5,276,585 (Smithers). Smithers generally relates to an “assembly of electronic components” capable of “removeably [sic] securing heat sinks in thermal communication with electronic device packages without using tools, adhesives, loose parts or the like.” Smithers, 1:5–9.

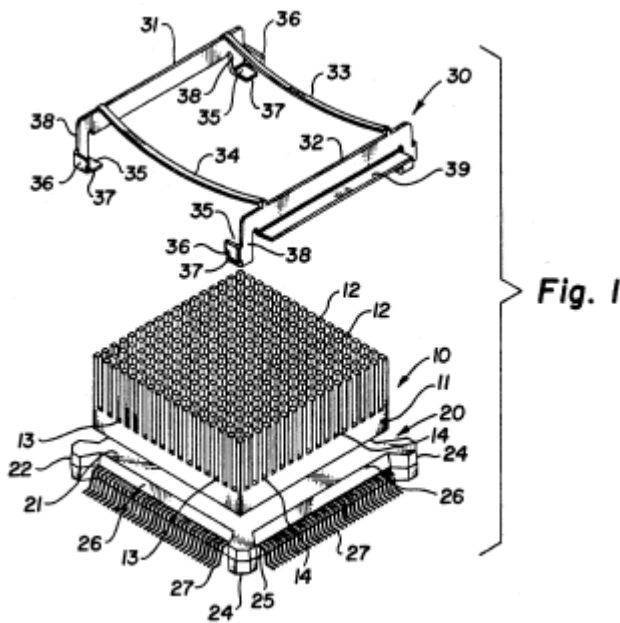

As shown in Figure 1, Smithers teaches a unitary mounting clip 30 that secures the heat sink 10 to an electronic device package 20. The clip secures the assembly by the pocket 35 fitting around the corners of the device package 22 and the transverse bars 33 and 34 fitting in the channels 14 formed by the pins 12 of the heat sink 10.

In its opinion, the district court relied on the report of Appellees’ expert, Dr. Carman, and concluded that Smithers disclosed every limitation in claims 1 and 2, except the “pads” and “recesses.” The district court determined that

the uses of pads and recesses were either well-known techniques or were disclosed in other prior art references and the '484 patent was merely an obvious improvement over the prior art. After noting that Malico failed to provide any technical evidence, the district court ruled that Appellees had met their high burden to overcome the presumption of validity and granted their motion for summary judgment.

On appeal, Malico argues that the district court erred by failing to perform any meaningful comparison of the Smithers reference to the claims of the '484 patent. Malico also asserts that the district court erred by finding the '484 patent invalid without discussing any rationale for why one of skill in the art would have made the modifications to Smithers that are present in the claims of the '484 patent. Finally, Malico contends that the district court should have considered Malico's evidence of secondary considerations.

In response, Appellees argue that the district court correctly found that Smithers discloses each of the limitations in the claims of the '484 patent except for pads. Notably, Appellees' brief does not cite to the district court's opinion for this assertion. That is because the district court did not make any such findings. Instead, to support these arguments, Appellees solely cite Dr. Carman's report. Throughout their argument, Appellees fail to appreciate that the district court did not perform the required analysis for establishing obviousness. *See Plantronics, Inc. v. Aliph, Inc.*, 724 F.3d 1343, 1354 (Fed. Cir. 2013) ("Where, as here, the necessary reasoning is absent, we cannot simply assume that an ordinary artisan would be awakened to modify prior art . . . ." (internal quotation marks omitted)). The district court failed to explain how Smithers either discloses or could be modified in an obvious manner to meet three limitations recited in the claims of the '484 patent: (1) the "rotation" limitation; (2) the "resilient legs each having a bent" limitation; and

(3) the “pair of positioning columns” and “pair of retaining edges” limitations. Accordingly, we vacate and remand for the district court to make the required findings.

#### A. “Rotation”

Both claims of the '484 patent recite a retaining device that can rotate such that in a first orientation the device accommodates a CPU assembly of a certain thickness and, after rotation to a second orientation, the retaining device accommodates a CPU assembly of a different thickness while still engaging the dissipater's top surface.

Although the district court's opinion is silent on the subject of this “rotation” limitation, Dr. Carman opined that “[i]n my opinion, while Smithers does not expressly refer to a second orientation, my interpretation of the figures, the symmetry of the structure and the location of channel 13 in the description is that in a second orientation, the resilient legs 33 would fall into the gaps between fins that Smithers calls channel 13.” J.A. 561. But the district court itself made no findings comparing the possible rotational capabilities of Smithers to the rotation requirement recited in the claims of the '484 patent. In addition, even to the extent that the Smithers retaining device is physically capable of being rotated in a way similar to the device claimed in the '484 patent, neither Dr. Carman nor the district court provided any basis for why one of skill in the art would rotate the Smithers retaining device in this manner. For example, nothing in Dr. Carman's report or in the district court's opinion suggests that such devices had been rotated in the past to enhance the usability of the retaining device. Even under a flexible and expansive approach to the obviousness inquiry, the raw ability to perform the rotation action without any reason to do so does not establish obviousness. *See KSR*, 550 U.S. at 418 (explaining that, although courts need not “seek out precise teachings” on each claim

limitation, courts must still “determine whether there was an apparent reason to combine the known elements in the fashion claimed by the patent at issue”). On remand, the district court must make such findings and determine whether the prior art discloses or suggests this rotation limitation.

B. “Resilient legs each having a bent”

The claims of the ’484 patent also recite “a plurality of resilient legs extending inwards from said first or second two opposite sides . . . and said resilient legs each having a bent.” ’484 patent, 3:23–26. The parties stipulated to the district court that the “bent” in the resilient leg should be construed as “material that extends from the resilient leg in a generally different direction.” J.A. 172.

Similar to the “rotation” limitation, the district court’s order did not expressly find or explain why the claimed “resilient legs . . . having a bent” are present in Smithers. Dr. Carman stated that Smithers discloses “a plurality of resilient legs (33 and 34) extending inward from the side” and that these “resilient legs are curved thus defining a bent leg and also has a bent at the intersection of resilient legs 33/34 with edge 32.” J.A. 561. Although the district court never expressly incorporated Dr. Carman’s opinions as its own, even if it had, Dr. Carman’s opinions are inconsistent with the stipulated construction of the term “bent.” Namely, Dr. Carman’s report does not explain how the curved beams of Smithers teach resilient legs with a bent (“material that *extends from the resilient leg* in a *generally different direction*”), where that bent is then either placed on “pads,” in “recesses,” or directly on the top surface of the heat dissipater, as claimed in the ’484 patent. Instead, Dr. Carman merely assumes that “the curved beam is equivalent to [a] resilient leg with [a] bent.” J.A. 606. The record lacks any analysis or findings as to why the claimed resilient legs, each having a bent, would have been an obvious modification over the curved

beams in Smithers. On remand, the district court must engage in such an analysis and articulate its reasoning with sufficient clarity to enable our review.

C. “Pair of positioning columns” and “pair of retaining edges”

Claims 1 and 2 recite that the retaining device has “a pair of positioning columns formed on first two opposite sides [and] a pair of retaining edges formed on second two opposite sides.” ’484 patent, 3:20–22. The district court construed “positioning columns” as “material that aligns the retaining device and the heat dissipater, preventing movement.” J.A. 181:15–17. Neither party requested a construction of “retaining edges.”

As with the two limitations discussed above, the district court’s opinion was also silent on whether Smithers disclosed the “pair of positioning columns” and the “pair of retaining edges” recited in the claims of the ’484 patent. Dr. Carman, on the other hand, opined that Smithers “has a pair of positioning columns 38 formed on a first two opposite sides and a pair of retaining edges 36/37 formed on second two opposite sides.” J.A. 561. Even if the district court had adopted this opinion as its own, neither Dr. Carman nor the district court provides any discussion as to how the four positioning columns 38 shown in the Smithers reference disclose the same “pair of positioning columns formed on first two opposite sides” recited in the claims of the ’484 patent. ’484 patent, 3:20–21 (claim 1), 4:10–11 (claim 2). Similarly, neither the district court nor Dr. Carman explained why the eight flanges 36/37 (two on each corner of the retaining device) could disclose the same “pair of retaining edges formed on second two opposite sides” recited in the claims of the ’484 patent. *Id.* at 3:21–22 (claim 1), 4:11–12 (claim 2). For these reasons, and for reasons similar to the two limitations discussed previously, the district court must examine the disclosures of the ’484 patent, the teachings of Smithers and

any other prior art references, and provide actual findings comparing the prior art to the claims of the '484 patent.

#### D. Secondary Considerations

Malico also argues that the district court erred in failing to consider Malico's evidence of secondary considerations of nonobviousness. True enough, evidence of secondary considerations of nonobviousness must always, when present, be considered in the obviousness analysis. *See In re Cyclobenzaprine*, 676 F.3d 1063, 1075–76 (Fed. Cir. 2012). However, in this case, the district court first found that the evidence on which Malico relies was inadmissible under Rule 37(c) of the Federal Rules of Civil Procedure. Malico is not appealing this evidentiary ruling. Consequently, Malico presented no admissible evidence of secondary considerations. We see no error in the district court's consideration of secondary considerations of nonobviousness.

#### CONCLUSION

For the foregoing reasons, we affirm the district court's judgment on damages and vacate the district court's judgment of invalidity. This case is remanded for further proceedings consistent with this opinion.

**AFFIRMED-IN PART, VACATED-IN-PART, AND  
REMANDED**

#### COSTS

Costs to Appellant.