

NOTE: This disposition is nonprecedential.

**United States Court of Appeals
for the Federal Circuit**

TMI PRODUCTS, INC.,
Plaintiff-Appellant

v.

ROSEN ENTERTAINMENT SYSTEMS, L.P.,
Defendant-Appellee

2014-1553

Appeal from the United States District Court for the
Central District of California in No. 5:12-cv-02263-RGK-
SP, Judge R. Gary Klausner.

Decided: April 2, 2015

REYNALDO C. BARCELO, Barcelo, Harrison & Walker,
LLP, Newport Beach, CA, argued for plaintiff-appellant.
Also represented by DAVID BRYANT WALKER, JOSHUA
CHARLES HARRISON, GUADALUPE M. GARCIA.

DAVID PAUL COOPER, Kolisch Hartwell, P.C., Portland,
OR, argued for defendant-appellee. Also represented by
OWEN W. DUKELOW, DESMOND JOHN KIDNEY, II.

Before LOURIE, BRYSON, and CHEN, *Circuit Judges*.

LOURIE, *Circuit Judge*.

TMI Products, Inc. (“TMI”) appeals from the decision of the United States District Court for the Central District of California granting summary judgment that Rosen Entertainment Systems, L.P. (“Rosen”) does not infringe claim 1 of U.S. Patent 7,597,393 (the “’393 patent”). See *TMI Prods., Inc. v. Rosen Elecs., L.P.*, No. 12-02263-RGK (C.D. Cal. Apr. 30, 2014) (“*Decision*”). Because we conclude that the district court did not err in construing claim 1, we affirm the grant of summary judgment of noninfringement.

BACKGROUND

TMI owns the ’393 patent relating to automotive headrest entertainment systems. The claimed invention is directed to a head restraint for vehicle seats having an integrated entertainment system that includes a video screen and a media player. ’393 patent col. 2 ll. 17–29. Independent claim 1 of the ’393 patent reads as follows:

1. A media assembly adapted to be installed into a seat back of a vehicle, the assembly comprising:

a mounting structure that is coupled to the seat back of the vehicle wherein the seat back defines a first outer surface visible to a viewer sitting in a back seat of the vehicle;

a display that displays media to a viewer sitting within the vehicle;

a media player having an input opening into which a user can position a media storage device wherein the media player provides signals to the display to thereby induce the display to visually display the contents of the media storage device;

a housing defining a recess having a first opening that receives both the display and the media player such that the display is positioned proximate the first opening of the recess with the media player positioned inward in the recess from the first opening such that the media player does not impede visual access to the display *wherein the housing is structured to permit selective access to the input opening of the media player to permit user positioning of the media storage device within the player* and

wherein the housing is adapted to be coupled to the mounting structure within the seat back of the vehicle to thereby retain the housing within the seat back such that the display is positioned adjacent the outer surface of the seat back;

wherein the housing defines a second opening and the media player is positioned within the recess such that the input opening of the media player is accessible through the second opening of the housing.

Id. col. 17 l. 59–col. 18 l. 21 (emphasis added).

The patent discloses two exemplary families of embodiments of a media assembly adapted to be installed into the seat back of a vehicle. Figure 9A discloses one embodiment: “a video system 300 for a vehicle seat or seat back 302 having a head restraint 304 with an integrated video display or monitor 306 and a side-loading media player 308” *Id.* col. 10 ll. 61–64; *see also id.* col 12 l. 60–col. 13 l. 9 (Figure 10 disclosing a head restraint with a top-loading media player.).

Figures 11A–12B disclose an alternative embodiment: “a video system 370 for the vehicle seat 302 having the head restraint 304 with the panel display 306 and media player 308 *pivotally attached* thereto.” *Id.* col. 13 ll. 22–25 (emphasis added). Exemplary figures of both families of embodiments are depicted below:

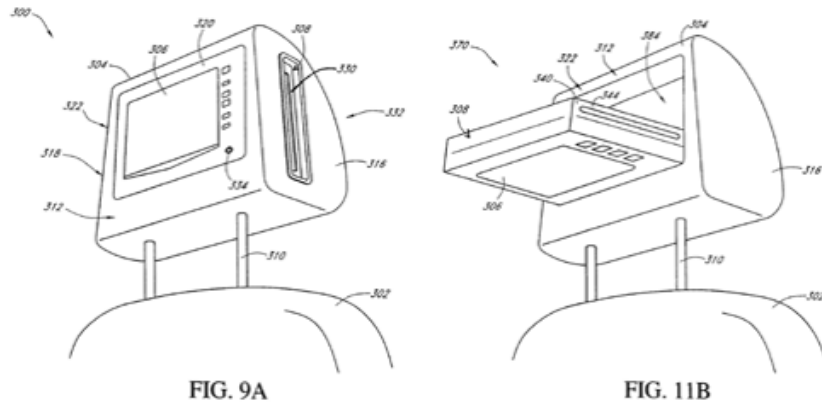

Id. figs. 9A, 11B.

According to TMI, in the patent application that would later issue as the '393 patent as originally filed at the U.S. Patent and Trademark Office (“PTO”), then-pending dependent claims 3–5 were directed to the embodiments disclosed in figures 9A–10. Dependent claims 6–10 were directed to the “pivotaly-mounted” embodiments disclosed in figures 11A–12B.

During prosecution, the Examiner issued a restriction requirement, distinguishing between product claims directed to “a media assembly for a headrest” and method claims for “mounting an entertainment system to a head restraint.” J.A. 689. The Examiner also identified three patentably distinct species subgroups: figure 9A, figure 9B, and figures 11A–C. J.A. 690. The Examiner required that the applicant elect a subgroup “to which the claims

shall be restricted if no generic claim is finally held to be allowable.” J.A. 690. In response, the applicant elected the product claims directed to “a media assembly for a headrest” and the subgroup containing figures 11A–12B. J.A. 695. The Examiner then withdrew claims 3–5 “from further consideration . . . as being drawn to a nonelected species, there being no allowable generic or linking claim.” J.A. 705.

The Examiner also rejected claim 1 as being anticipated by the prior art. J.A. 707–08. The Examiner found, “[w]ith respect to claim 1, [that the prior art] discloses a media assembly (10) adapted to be installed into a seat back (50) of a vehicle . . . wherein the housing is *structured to permit selective access, because it pivots in and out of carrier member (17)*.” J.A. 708 (emphasis added). The applicant eventually overcame that rejection by establishing prior invention, and the application issued as the ’393 patent containing claim 1.

TMI subsequently brought suit against Rosen, a competitor of TMI, alleging that the Rosen AV7900 and the Rosen CS9000 products directly infringe claim 1 of the ’393 patent. TMI and Rosen filed cross-motions for summary judgment of infringement and noninfringement, respectively.

The district court construed claim 1 of the ’393 patent and, based on that construction, granted Rosen’s motion for summary judgment of noninfringement. The court construed the phrase “the housing is structured to permit selective access to the input opening” to require that “the housing is structured to be capable of moving between an accessible and an inaccessible orientation.” *Decision* at 7. The court found that TMI’s proposed construction of “to permit selective access” as “to allow choice for entry” created at least two redundancies in the claim language. *Id.* at 5–6. First, according to the court, if “to permit selective access” referenced a user’s choice to either access

the device or not, “the word ‘selective’ could be omitted entirely without doing any violence to the limitation’s meaning.” *Id.* at 5. Second, the court found that TMI’s construction would render the term “the housing is structured to permit selective access to the input opening of the media player” unnecessary in light of the final limitation of claim 1, which requires that “the media player is positioned within the recess such that the input opening of the media player is accessible through the second opening of the housing.” *Id.*

The court found that any evidence of a disclaimer in the prosecution history was inconclusive; however, the court noted that the Examiner’s interpretation of the claim language was consistent with Rosen’s proposed construction. *Id.* at 6. The court found, with respect to the prior art, that the Examiner “understood ‘structured to permit selective access’ to mean capable of being made accessible or inaccessible by, for instance, pivoting in the recess.” *Id.*

Having construed claim 1, the court examined Rosen’s products *in camera* and concluded that “[t]he accused products’ housing sits within the recess of the headrest, and cannot be manipulated to expose the input opening, which is always accessible from the top of the headrest.” *Id.* at 8. Thus, based on the court’s construction of the claim and its findings regarding the accused products, the court granted Rosen’s motion for summary judgment of noninfringement. *Id.*

TMI timely appealed to this court. We have jurisdiction pursuant to 28 U.S.C. § 1295(a)(1).

DISCUSSION

We review the grant of summary judgment under the law of the regional circuit in which the district court sits, here, the Ninth Circuit. *Lexion Med., LLC v. Northgate Techs., Inc.*, 641 F.3d 1352, 1358 (Fed. Cir. 2011). Apply-

ing the law of the Ninth Circuit, we review the grant of summary judgment *de novo*. *Humane Soc’y of the U.S. v. Locke*, 626 F.3d 1040, 1047 (9th Cir. 2010). Summary judgment is appropriate when, drawing all justifiable inferences in the nonmovant’s favor, “there is no genuine dispute as to any material fact and the movant is entitled to judgment as a matter of law.” Fed. R. Civ. P. 56(a); *Anderson v. Liberty Lobby, Inc.*, 477 U.S. 242, 255 (1986).

In this case, we review the district court’s claim construction *de novo* because the intrinsic record fully determines the proper construction, and the district court’s construction was not based on extrinsic evidence. See *Teva Pharm. USA, Inc. v. Sandoz, Inc.*, 574 U.S. ___, 135 S. Ct. 831, 841 (2015). A patent is a fully integrated written instrument and the claims must be read in view of the specification of which they are a part. *Phillips v. AWH Corp.*, 415 F.3d 1303, 1317 (Fed. Cir. 2005) (en banc). A court should also consult the patent’s prosecution history, which, like the specification, provides evidence of how the PTO and the inventor understood the claimed invention. *Id.*

TMI argues that the district court erred in construing “to permit selective access,” and that, when using the plain and ordinary meaning of the claim language, the phrase should be construed as “to allow choice for entry.” Appellant’s Br. 28. According to TMI, dependent claims 3–5, as originally filed, were drawn to figures 9A–10. TMI contends that claim 1 must have been at least as broad or broader in scope than then-pending claims 3–5, and the withdrawal of claims 3–5 did not alter the scope of claim 1. Thus, TMI asserts that the meaning of “to permit selective access” must not exclude the embodiment shown in figures 9A–10.

Rosen responds that the court correctly construed “to permit selective access.” According to Rosen, the plain and ordinary meaning of “to permit selective access” is

switching between having and not having access. Rosen further argues that TMI disavowed coverage of figures 9A–10 by electing the embodiments of figures 11A–12B in response to the restriction requirement.

We agree with Rosen that the district court correctly construed “the housing is structured to permit selective access to the input opening” to require that “the housing is structured to be capable of moving between an accessible and inaccessible orientation.” That construction gives meaning to the word “selective.” When considering multiple possible claim constructions, “[a] claim construction that gives meaning to all the terms of the claims is preferred over one that does not do so.” *Merck & Co., Inc. v. Teva Pharm. USA, Inc.*, 395 F.3d 1364, 1372 (Fed. Cir. 2005). Read in the context of the specification, the district court’s construction of “to permit selective access” gives meaning to all of the terms of the claim. In the description of figures 11A–12B, the housing limits access to the input opening of the media player using a pivot member:

[T]he pivot member 386 allows for the video system 370 to be pivoted outward from the recess 384 so that a user can *readily access* the media player 308, and, in addition, the pivot member 386 also allows for the video system 370 to be pivoted towards the recess 384 so as to engage the recess 384 in the *retracted orientation* 382

’393 patent col. 14 ll. 11–16 (emphases added). Thus, the housing permits access to the input opening of the media player, and that access is *selective* because the housing is structured to be capable of moving between an accessible orientation and a retracted, inaccessible orientation. The court correctly stated that the scope of claim 1 is not necessarily limited to the pivotally attached embodiment.

In contrast, TMI’s proposed construction creates redundancies in the claim language. Under TMI’s construction of “to permit selective access” as “to allow choice for

entry,” the term “selective” becomes unnecessary. As the district court found, by definition, one with access to the input opening may choose whether to make use of it, and as a result, TMI’s proposed construction renders the term “selective” unnecessary. TMI argues that “selective” is necessary because it distinguishes “selective access” from “visual access,” as recited earlier in claim 1, but we find that distinction unavailing. But there is no need to distinguish “visual access,” as it applies in the context of a display, from “access,” as it applies in the context of the input opening of the media player.

TMI’s proposed construction also creates a redundancy between the “selective access” limitation and the final limitation of claim 1, which provides: “wherein the housing defines a second opening and the media player is positioned within the recess such that the input opening of the media player is accessible through the second opening of the housing.” *Id.* col. 18 ll. 18–21. As so construed, the narrower final limitation would render the “selective access” limitation redundant because the final limitation would require that the housing permit access to the input opening of the media player as well as further define the structure of the housing. Thus, the broader “selective access” limitation would be unnecessary.

TMI’s additional argument that dependent claims 3–5, as originally filed, were drawn to figures 9A–10, and thus that independent claim 1 must not exclude the embodiment shown in figures 9A–10, is also unavailing. TMI’s argument focuses on the drafter’s intent with respect to the drafting of the original claims, but intent alone, without further evidence, does not inform the construction of claim 1. *See Howmedica Osteonics Corp. v. Wright Med. Tech., Inc.*, 540 F.3d 1337, 1347 (Fed. Cir. 2008) (“We hold that inventor testimony as to the inventor’s subjective intent is irrelevant to the issue of claim construction.”). Although originally-filed dependent claims 3–5 may have been intended to cover figures 9A–

10, and claim 1 may have initially been intended as a generic independent claim, it does not follow from the “selective access” language that claim 1 covers the embodiments in figures 9A–10. As drafted and issued, claim 1 never did cover those embodiments.

Finally, both parties argue that the prosecution history affects the construction of claim 1. “Absent a clear disavowal or contrary definition in the specification or the prosecution history, the patentee is entitled to the full scope of its claim language.” *Home Diagnostics, Inc. v. LifeScan, Inc.*, 381 F.3d 1352, 1358 (Fed. Cir. 2004). We conclude that none of the statements in the prosecution history rise to the level of a clear disavowal or otherwise support a departure from the claim language and the written description. Thus, the district court correctly construed “the housing is structured to permit selective access to the input opening” to require that “the housing is structured to be capable of moving between an accessible and inaccessible orientation.” We have considered the parties’ remaining arguments and conclude that they are without merit.

CONCLUSION

TMI does not contend that Rosen infringes under the district court’s construction. Thus, because the district court correctly construed the language of claim 1 of the ’393 patent, the decision of the court granting Rosen’s motion for summary judgment of noninfringement is affirmed.

AFFIRMED