

NOTE: This disposition is nonprecedential.

**United States Court of Appeals
for the Federal Circuit**

SUPERIOR INDUSTRIES, INC.,
Plaintiff-Appellant

v.

MASABA, INC.,
Defendant-Appellee

2015-1594

Appeal from the United States District Court for the
District of Minnesota in No. 0:10-CV-00764-DWF-LIB,
Judge Donovan W. Frank.

Decided: June 2, 2016

JOHN M. WEYRAUCH, Dicke, Billig & Czaja, PLLC,
Minneapolis, MN, argued for plaintiff-appellant. Also
represented by PETER R. FORREST, PAUL P. KEMPF.

TIM R. SHATTUCK, Woods, Fuller, Shultz & Smith
P.C., Sioux Falls, SD, argued for defendant-appellee. Also
represented by SANDER J. MOREHEAD; JEFFREY CARL
BROWN, Sapientia Law Group PLLC, Minneapolis, MN.

Before REYNA, HUGHES, and STOLL, *Circuit Judges*.

HUGHES, *Circuit Judge*.

Superior Industries sued Masaba for infringing its patents on a drive-over truck dump conveyor system and a braced telescoping support strut. The district court construed a number of terms across the five patents at issue, and granted summary judgment of noninfringement as to all asserted claims. On appeal, Superior argues that the district court erred in construing the claims. Because we find that the district court correctly construed “ramp section,” “support frame,” and “channel beam,” we affirm.

I

Superior Industries, Inc. (Superior) owns two sets of patents that we refer to as the “Unloader Patents” and the “Support Strut Patents.” The Unloader Patents are U.S. Patent No. 7,424,943, U.S. Patent No. 7,607,529, and U.S. Patent No. 7,845,482.¹ The Support Strut Patents are U.S. Patent No. 7,470,101 and U.S. Patent No. 7,618,231.²

The Unloader Patents are directed to a truck unloader system with a drive-over ramp system and a conveyor system to transport deposited material from a truck to a hopper. ’943 patent, col. 1 ll. 39–45. The drive-over ramp has three ramp sections, where the third ramp section is located between the first and second ramp sections. *Id.* at col. 1 ll. 47–52.

¹ The Unloader Patents are related to one another and share substantially similar specifications. The ’943 patent is the parent patent.

² The ’231 patent is a continuation of the ’101 patent and has a substantially similar specification.

The independent claims at issue in the Unloader Patents are claim 2 of the '943 patent, claims 1 and 15 of the '529 patent, and claims 1 and 5 of the '482 patent.³ The primary disputed terms are “support frame” and “ramp section,” which appear in all of the asserted independent claims except for claim 15 of the '529 patent.

Claim 2 of the '943 patent is representative of claim 1 of the '529 patent and claim 1 of the '482 patent,⁴ and contains the “support frame” term. Claim 2 reads, in relevant part:

2. A portable truck dump comprising: . . .

a support frame positionable on the ground adjacent to the first end of the frame on each of the first and second sides of the frame, the support frame comprising a frame member extending along the second end of each of the first and second ramps, the frame member having a height generally equal to a height of the second end of each ramp when the second end of each ramp is supported above the ground, wherein the frame member is configured to support an end of an earthen ramp constructed against the frame member to provide a material transport vehicle access to the first and second ramps to deposit material over the grate, and to maintain the integrity of the earthen ramp when the first and second ramps are pivoted toward the grate.

³ Superior asserted claims 2–6 of the '943 patent, claims 1–5, 7, 9, 15, and 19 of the '529 patent, and claims 1–3 and 5 of the '482 patent.

⁴ Rather than a “support frame,” claim 1 of the '529 patent requires a “ramp support frame” and claim 1 of the '482 patent requires a “U-shaped frame.” The parties treat these terms as equivalent to “support frame,” and the district court issued the same construction as to all three terms.

'943 patent, col. 8 ll. 5–43.

Claim 5 of the '482 patent contains the “ramp section” term,⁵ and reads, in relevant part:

5. A portable conveyor system with a drive-over material receiving opening, the conveyor system comprising:

...

a drive-over ramp system near the first end of the frame, the drive-over ramp system comprising a first ramp section pivotally mounted on a first side of the frame, the first ramp section having a first pair of side walls on opposite sides thereof, a second ramp section pivotally on a second side of the frame, the second ramp section having a second pair of side walls on opposite sides thereof, and a third ramp section supported on the frame between the first and second ramp sections, the third ramp section comprising a grate positioned over a portion of the conveyor belt assembly for receiving bulk material from a material transport vehicle and having a third pair of side walls on opposite sides thereof, the first, second and third pair of side walls cooperating to retain excess bulk material deposited by the material transport vehicle on the drive over ramp system, wherein the first and second pair of side walls are moveable relative to the third pair of side walls as the first and second ramp sections pivot from a first lowered position to a second raised position.

'482 patent, col. 8 ll. 26–55.

The Support Strut Patents are directed to a telescoping support strut that holds up a conveyor system. '101 patent, col. 1 ll. 35–37. The support strut is comprised of

⁵ Claim 1 of the '529 patent also contains the “ramp section” limitation, but the court’s construction was issued with respect to claim 5 of the '482 patent. J.A. 886–87.

two sections: a “first strut section” and a “second strut section.” Each strut section is comprised of a pair of parallel beams that are braced together. *Id.* at col. 1 ll. 37–45. The second strut section’s beams are referred to as “channel beams,” and are configured to “telescopically receive and substantially surround a respective beam of the first strut section.” *Id.* at col. 1 ll. 46–48.

The independent claims at issue in the Support Strut Patents are claims 1, 6, and 8 of the ’101 patent and claims 1, 7, 14, and 15 of the ’231 patent.⁶ The primary disputed terms are “channel beam” and “elongate opening.” The term “channel beam” appears in all of the asserted independent claims. Claim 1 of the ’101 patent is representative, and reads, in relevant part:

1. A telescoping support strut configured to support a conveyor assembly of a portable conveyor system relative to a base frame, the support strut comprising: . . .

a second strut section having a first generally C-shaped channel beam and a second generally C-shaped channel beam, the first and second channel beams having a generally equal length and being generally parallel to one another, the first and second channel beams each comprising a perimeter wall and an elongate opening that extends the length of the first and second channel beams, the elongate opening of the first channel beam facing the elongate opening of the second channel beam, the first and second channel beams defining an open space between the respective elongate openings, and a plurality of braces coupled between the first and second channel beams outside of the open space, the first and second channel beams each having a first end configured to pivotally connect to the base frame of the portable con-

⁶ Superior asserted claims 1–8 of the ’101 patent and claims 1–15 of the ’231 patent.

veyor system and a second end configured to receive the second ends of the first and second beams, respectively, of the first strut section, the first strut section movable within the second strut section . . .

'101 patent, col. 8 ll. 24–58.

The court construed a number of terms across the five asserted patents. For the Unloader Patents, “support frame” was construed as “a frame consisting of a pair of side frame members and an end frame member that provides a barrier for supporting an earthen ramp that can also provide support for a pivoting ramp when it is in a lowered position.” J.A. 862. The term “ramp section” was construed as “first/second ramp section including a ramp and a frame consisting of a pair of side frame members and an end frame member that provides a barrier for supporting an earthen ramp that can also provide support for the pivoting ramp when it is in a lowered position.” J.A. 887. For the Support Strut Patents, the term “channel beam” was construed as “a metal beam having a perimeter wall with three complete sides and one partial side configured to substantially surround all four sides of the respective beam it engages with.” J.A. 899. The term “elongate opening” was construed as “slot defined by the openings in the partial fourth sides of the channel beams.” J.A. 900.

Superior sued Masaba, Inc. (Masaba) for infringing the Unloader Patents and Support Strut Patents through the manufacture and sale of five different truck unloader models. The district court granted Superior’s summary judgment motion of noninfringement subject to the right to appeal the court’s claim constructions, because Superior had conceded that it could not prevail on its infringement claims under the court’s constructions. We vacated the district court’s decision and remanded for further clarification because the court’s summary judgment opinion failed to explain how the court’s construction of

any term would affect Superior's infringement claims. *Superior Indus., Inc. v. Masaba, Inc.*, 553 F. App'x 986, 990–91 (Fed. Cir. Jan. 16, 2014). On remand, the court granted Masaba's summary judgment of noninfringement as to both sets of patents.

Superior appeals. We have jurisdiction under 28 U.S.C. § 1295(a)(1).

II

We review a grant of summary judgment under the law of the regional circuit. *Charles Mach. Works, Inc. v. Vermeer Mfg. Co.*, 723 F.3d 1376, 1378 (Fed. Cir. 2013). The Eighth Circuit reviews summary judgment motions de novo. *Wilson v. Spain*, 209 F.3d 713, 716 (8th Cir. 2000). We review claim construction de novo, and underlying factual determinations concerning extrinsic evidence for clear error. *Teva Pharms. USA, Inc. v. Sandoz, Inc.*, 135 S. Ct. 831, 841 (2015). Infringement is a question of fact. *01 Communique Lab., Inc. v. LogMeIn, Inc.*, 687 F.3d 1292, 1296 (Fed. Cir. 2012). “On appeal from a grant of summary judgment of non-infringement, we determine whether, after resolving reasonable factual inferences in favor of the patentee, the district court correctly concluded that no reasonable jury could find infringement.” *Id.* (internal quotation marks omitted).

A

The court granted summary judgment of noninfringement of the Unloader Patents based on its claim constructions of “support frame” and “ramp section.” J.A. 12–15. Both constructions require the support frame be capable of supporting an earthen ramp, which enables a truck to access the claimed low-profile ramp system. The court determined that Masaba's accused designs do not infringe because they lack an end frame member and use

steel ramps, not earthen ramps.⁷ J.A. 10–11, 14–15. In particular, the court explained that Masaba’s designs A–C have “no structure between the pivoting ramps and the portable steel access ramps that comprises a barrier at all,” J.A. 14, and Masaba’s designs D and E “do not have any structure that could be characterized as a ramp support frame,” J.A. 15.

Superior argues that the court erred in construing “ramp section” to require a “support frame,” that in turn, requires the presence of an earthen ramp. We do not find Superior’s arguments persuasive based on the specification and claim language. *See Phillips v. AWH Corp.*, 415 F.3d 1303, 1313–14 (Fed. Cir. 2005) (en banc).

We start with the court’s construction of “support frame.” The patents indicate that the “support frame” is capable of supporting an earthen ramp. For example, claim 2 of the ’943 patent defines the “support frame” as “comprising a frame member” that “is *configured to support an end of an earthen ramp* constructed against the frame member to provide a material transport vehicle access.” ’943 patent, col. 8 ll. 32–40 (emphasis added). And, the specifications explicitly define the “present invention” by the support frame’s two functions, the first of which requires the capability to support an earthen ramp:

Ramp support frame 32 provides two independent functions. *First, ramp support frame 32 serves as a low profile support structure for building an earthen ramp to access the ramp system 20. Sec-*

⁷ While claim 15 of the ’529 patent does not explicitly recite a “support frame,” it similarly requires a “first portion” of a ramp “configured to support an earthen ramp” and that “maintains support of the earthen ramp.” *See* ’529 patent, col. 10 ll. 5–15.

ond, ramp support frame can additionally serve as a stable base to support ramp 34 at a level of end frame member 40B. The present invention contemplates utilizing the first function of ramp support frame 32 alone, or a combination of the first and second function of ramp support frame 32.

'943 patent, col. 3 ll. 26–34 (emphasis added); *see also* '529 patent, col. 3 ll. 20–28; '482 patent, col. 3 ll. 30–37. Based on the patents' clear and unmistakable statements, the district court did not err in concluding that the accused devices lack a support frame that forms a barrier capable of supporting an earthen ramp.

As to the “ramp section” construction, the '943 patent explicitly defines the “ramp section” to comprise a support frame and a ramp. '943 patent, col. 1 ll. 54–55 (“Each of the first and second ramp sections comprises a support frame and a ramp.”). While Superior argues that the specifications contain inconsistencies as to whether the support frame is part of the ramp section, we do not find these alleged inconsistencies persuasive in light of the explicit definition of the “ramp section” in the '943 patent, which applies to the '482 patent. *See Omega Eng'g, Inc. v. Raytek Corp.*, 334 F.3d 1314, 1334 (Fed. Cir. 2003) (“[W]e presume, unless otherwise compelled, that the same claim term in the same patent or related patents carries the same construed meaning.”). Therefore, we affirm the district court's constructions of “support frame” and “ramp section” in the Unloader Patents and its summary judgment of noninfringement of the Unloader Patents.

B

The court granted summary judgment of noninfringement of the Support Strut Patents, finding that Masaba's accused designs are comprised of tubes that do not have channels, and therefore, do not have “channel beams,” and that Superior conceded noninfringement under the court's claim construction in summary judg-

ment briefing. J.A. 17; J.A. 955. In light of Superior’s concession, we only address whether the court erred in construing “channel beam,” because that term appears in all of the asserted independent claims of the Support Strut Patents.

The parties dispute whether the “channel beam” has three sides or four sides, where the fourth side is a partial side. We find that the court correctly construed “channel beam” because the specification and claims make clear that a “channel beam” must have four sides, where the fourth side is a partial side. *See Phillips*, 415 F.3d at 1313–14.

First, the channel beams are consistently described as “configured to surround substantially *all four sides* of the respective beams that they engage with,” ’101 patent, col. 5 ll. 44–46 (emphasis added); *see also id.* at col. 1 ll. 46–48; *id.* at col. 5 ll. 24–26, which necessarily requires the channel beam to have more than three sides. In addition, claim 8 of the ’101 patent requires that each channel beam “substantially surround a respective beam of the first strut section.” *Id.* at col. 10 ll. 23–29.

Second, except for claim 8 of the ’101 patent, all of the disputed independent claims of the Support Strut Patents describe the channel beam as “C-shaped.” For example, claim 1 of the ’101 patent describes a “first generally C-shaped channel beam and a second generally C-shaped channel beam,” ’101 patent, col. 8 ll. 34–36, and claim 1 of the ’231 patent states that “the first and second channel beams each compris[e] a generally C-shaped perimeter wall,” ’231 patent, col. 8 ll. 64–66. The specifications also describe the channel beam as “generally C-shaped.” ’101 patent, col. 5 ll. 59–60; ’231 patent, col. 6 ll. 12–13.

Of importance, the patents also distinguish between channel beams and “U-shaped” beams, where the former is comprised of the latter. As depicted on the right side of Figure 4B in both patents, a channel beam 60 is made up

of two U-shaped beams 123 and 124 joined together by plate 125. '101 patent, col. 5 ll. 10–21. A “U-shaped” beam 123 has three sides, comprising “a first leg 126, a second leg 127, and a base 128 connecting between first and second legs 126, 127.” *Id.* at col. 5 ll. 12–14. This arrangement of the two “U-shaped” beams results in a “configuration of first channel beam 60” with “three complete sides (base 128, plate 125, base 138) and one partial fourth side (defined by legs 126, 136) that combine to substantially surround” a beam of the first strut section. *Id.* at col. 5 ll. 21–26.

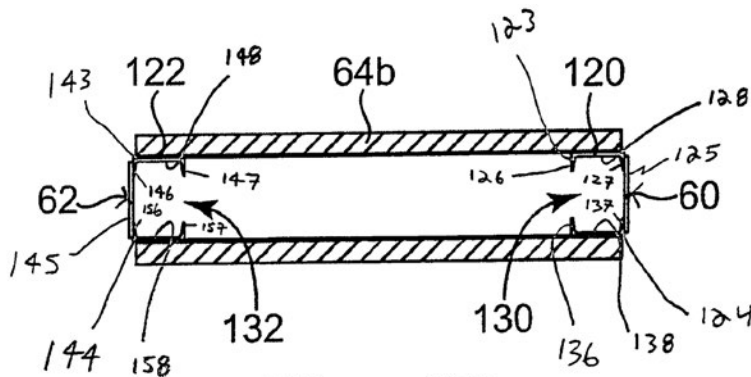

Fig. 4B

Thus, the patents clearly use the term “U shaped” to describe a three-sided beam that forms part of a channel beam that is consistently described as “C-shaped.”

We find that based on the patent disclosures as a whole, the term “C shaped” must have a distinct meaning from “U shaped.” See *Phillips*, 415 F.3d at 1321 (“[T]he ‘ordinary meaning’ of a claim term is its meaning to the ordinary artisan after reading the entire patent.”); *Anderson v. Int’l Eng’g & Mfg., Inc.*, 160 F.3d 1345, 1348–49 (Fed. Cir. 1998) (“[A] word describing patented technology takes its definition from the context in which it was used by the inventor.”). In light of the clear differentiation between “U-shaped” and “C-shaped” beams, and the

description of the “channel beam” as either “C-shaped” or “substantially surround[ing] a respective beam of the first strut section,” we agree with the district court’s construction of “channel beam.”

III

We have considered Superior’s remaining arguments, and find them unpersuasive. Because the district court did not err in construing the terms “support frame,” “ramp section” and “channel beam,” we affirm the grant of summary judgment of noninfringement.

AFFIRMED