

United States Court of Appeals for the Federal Circuit

IN RE: AFFINITY LABS OF TEXAS, LLC,
Appellant

2016-1092, 2016-1172

Appeals from the United States Patent and Trade-
mark Office, Patent Trial and Appeal Board in Nos.
90/010,333, 95/001,223, 95/001,264.

Decided: May 5, 2017

WILLIAM MANSKE, Robins Kaplan LLP, Minneapolis,
MN, argued for appellant. Also represented by RYAN
MICHAEL SCHULTZ.

ROBERT MCBRIDE, Office of the Solicitor, United
States Patent and Trademark Office, Alexandria, VA,
argued for intervenor Michelle K. Lee. Also represented
by THOMAS W. KRAUSE, JOSEPH MATAL, SCOTT
WEIDENFELLER.

Before TARANTO, CHEN, and STOLL, *Circuit Judges*.
CHEN, *Circuit Judge*.

This appeal arises from two *inter partes* reexamina-
tions and an *ex parte* reexamination of U.S. Patent No.

7,324,833 (the '833 patent), owned by Affinity Labs of Texas, LLC (Affinity). Richard King requested *ex parte* reexamination of all original claims of the '833 patent, based on multiple asserted grounds of unpatentability. Volkswagen Group of America, Inc. (Volkswagen) requested *inter partes* reexamination of all claims based on additional, different asserted grounds of unpatentability. And Apple Inc. (Apple) requested *inter partes* reexamination of all claims based on still different asserted grounds of unpatentability. The United States Patent and Trademark Office (PTO) granted all three requests and *sua sponte* merged these three reexaminations into a single proceeding.

Volkswagen subsequently received an adverse final judgment in a parallel district court proceeding, upholding the validity of claims 28 and 35 of Affinity's '833 patent. In response, Affinity petitioned the PTO to vacate the entire merged reexamination proceeding, arguing that the estoppel provision in pre-America Invents Act (AIA) 35 U.S.C. § 317(b)¹ extends to all parties, not just Volkswagen, and all claims challenged in the three reexaminations, not just litigated claims 28 and 35. The PTO denied Affinity's termination request, but it severed the Volkswagen reexamination from the merged proceeding and held that no rejection could be maintained in that reexamination as to the claims at issue in the district

¹ When Congress enacted the AIA, it replaced the extant statutory provisions for *inter partes* reexamination with provisions for a new type of proceeding, *inter partes* review. In doing so, Congress amended the provisions of 35 U.S.C. § 317 to apply only to *inter partes* review proceedings, which, by definition, are filed post-AIA. Congress also specified that the pre-AIA provisions of the *inter partes* reexamination statute remain applicable to *inter partes* reexamination proceedings.

court action. The Examiner then evaluated the Volkswagen reexamination separately from the merged King/Apple reexamination and ultimately issued a Right of Appeal Notice in each proceeding, rejecting numerous claims of the '833 patent as unpatentable. The Patent Trial and Appeal Board (Board) affirmed the Examiner's rejections. See *Apple Inc. v. Affinity Labs of Tex., LLC*, No. 2015-004281, Reexamination Nos. 95/001,264 and 90/010,333, 2015 WL 4038964, at *1 (P.T.A.B. June 30, 2015) (-4281 Board Decision); *Apple Inc. v. Affinity Labs of Tex., LLC*, No. 2015-006122, Reexamination No. 95/001,223, 2015 WL 5092841, at *1 (P.T.A.B. Aug. 26, 2015) (-6122 Board Decision). Affinity appealed to this court and the Director of the United States Patent and Trademark Office (Director) intervened. We have jurisdiction under 28 U.S.C. § 1295(a)(4)(A).

Affinity first argues that the PTO erred in maintaining the reexaminations in light of the final decision that Volkswagen failed to prove invalidity of two of the patent's claims, which were asserted in the co-pending litigation and, therefore, the Board's decisions in the reexaminations should be reversed pursuant to the section 317(b) estoppel provision. Affinity also asserts that, assuming the reexaminations were properly maintained, the Board's decisions are based on misreadings of the asserted prior art and a misevaluation of Affinity's objective indicia evidence of nonobviousness. Because the plain language of pre-AIA section 317(b) precludes Affinity's estoppel argument and because we see no error in the -4281 Board Decision upholding the Examiner's findings of unpatentability as to all claims at issue, we affirm. We, therefore, dismiss as moot Affinity's appeal of the -6122 Board Decision upholding the unpatentability of a subset of claims affirmed as unpatentable in the -4281 Board Decision.

BACKGROUND

I. The '833 Patent

The '833 patent relates to a system and method for connecting a portable media player, such as an MP3 player, to a different electronic device, such as a car audio system. '833 patent col. 3, l. 35 – col. 4, l. 34. When the portable media player is connected to the different electronic device, the system provides the user with a graphical user interface on the display of that different electronic device. *Id.* col. 11, ll. 28–44. The user can then select and play music stored on the portable media player by pressing soft buttons displayed in the graphical user interface of the different electronic device. The '833 patent's claims are directed to systems and methods of displaying on the different electronic device a menu of titles associated with media files stored on the portable media player. Claim 1 is representative:

1. An audio system, comprising:

a portable electronic device having a display, a memory, and an audio file player;

a first portion of software saved at the portable electronic device and configured to initiate a displaying of a graphical interface item on the display, the graphical interface item comprising a name associated with an audio file saved in the memory;

a mounting location on the portable electronic device that includes a physical interface configured to communicatively couple the portable electronic device to a different electronic device having an associated display; and

an other portion of software saved at the portable electronic device and configured to communicate a representation of the graphical interface item to the different electronic device via the physical interface to facilitate a displaying of the representation on the associated display, wherein the portable electronic device is configured to communicate interface information to the different electronic device in order to allow a user to view at least a partial representation of a graphical user interface that includes the graphical interface item on the associated display, wherein the graphical user interface comprises a plurality of preprogrammed soft buttons that are linked to respective audio information sources.

Id. col. 18, ll. 36–61.

II. Merger and Severance of the Reexaminations

Richard King filed a request for *ex parte* reexamination of all claims of the '833 patent on November 7, 2008. Volkswagen filed a request for *inter partes* reexamination of all claims of the '833 patent on September 22, 2009, soon after Affinity sued Volkswagen for infringement of the '833 patent, among other patents, in district court. Apple also filed a request for *inter partes* reexamination of all claims of the '833 patent on November 13, 2009, after Affinity brought suit against Apple on a series of patents, including the '833 patent. The PTO granted all three reexamination requests, and on June 14, 2010, the PTO *sua sponte* merged the three reexaminations into one proceeding. In addition to traversing the asserted grounds of rejection, Affinity also sought to add new claims 36–49.

During the merged reexamination proceeding, Apple and Affinity reached a settlement, Apple took a license to the '833 patent, and the parties filed a joint stipulation of dismissal in the co-pending district court case. Pursuant to the joint stipulation, the district court dismissed Affinity's infringement action with prejudice and Apple's invalidity counterclaims without prejudice. Apple then filed a notice of non-participation in the reexamination on October 3, 2011. The district court litigation between Affinity and Volkswagen, however, proceeded to trial and a jury returned a verdict that Volkswagen infringed claims 28 and 35 of the '833 patent and Volkswagen had not proven that the two asserted claims are invalid in view of prior art it presented at trial. Volkswagen initially appealed the verdict but dismissed its appeal following its own settlement with Affinity. Volkswagen filed a notice of non-participation in the reexamination on June 14, 2012.

Affinity then petitioned the PTO to terminate the entire merged proceedings under 35 U.S.C. § 317(b). Affinity argued that a final judgment was entered adverse to *inter partes* requester Volkswagen regarding the validity of the challenged claims, *inter partes* requester Apple no longer had a legal or economic incentive in maintaining the reexamination given the settlement, and all grounds for unpatentability raised by the *ex parte* reexamination were traversed. The PTO dismissed Affinity's request to terminate the merged proceeding. It did, however, sever the Volkswagen reexamination and held the estoppel provision of pre-AIA section 317(b) would apply in the severed proceeding as to independent claims 28 and 35. Therefore, the PTO concluded that no rejections would be asserted in that proceeding of claims 28 and 35 and as a natural consequence, their dependent claims 29–34, 48, and 49.

III. Rejections and Appeal

The Examiner issued Right of Appeal Notices in both proceedings. In the severed Volkswagen reexamination, the Examiner rejected claims 1–5, 8–20, and 22–27 as unpatentable based on various prior art references and combinations. The Examiner stated that claims 28–35, 48, and 49 were no longer subject to reexamination; claims 6, 7, and 21 were patentable over the asserted art; and newly added claims 36–46 were objected to as dependent upon rejected base claims but would be allowed if rewritten in independent form. In the merged King/Apple reexamination proceeding, the Examiner rejected claims 1–27 and new claims 37–42, 45, and 46, added during reexamination. The Examiner stated that claims 28–35, 48, and 49, however, are patentable over the asserted prior art and claims 36, 43, 44, and 47 are objected to as dependent upon rejected base claims but would be allowed if rewritten in independent form.

Affinity appealed and the Board affirmed the Examiner’s rejections in two final written decisions. In particular, the Board sustained the following grounds of rejection in the merged King/Apple reexamination:

- Claims 1–27, 39, and 45 as anticipated by U.S. Patent No. 6,671,567 (Dwyer), or obvious over Dwyer in combination with additional secondary references; and
- Claims 1–26, 37–42, and 45–46 as obvious over U.S. Patent No. 6,694,200 (Naim) and U.S. Patent No. 6,728,531 (Lee), or obvious over Naim and Lee in combination with additional secondary references.²

² We note that the Examiner actually rejected claim 36 as obvious over Naim in view of Lee in the body of the

The Board also sustained the following grounds of rejection in the severed Volkswagen reexamination:

- Claims 1–5, 8–11, 13–18, 20, 22–23, and 25–27 as anticipated by EP Patent App. No. EP0982732 (Hahm) or obvious over Hahm in combination with additional secondary references; and
- Claims 1–3, 5, 8–17, 19–20, 22–26, and 27 as anticipated by U.S. Patent No. 6,407,750 (Gioscia) or obvious over Gioscia in combination with additional secondary references.

DISCUSSION

We review the PTO’s decisions under the standards set forth in the Administrative Procedure Act (APA), 5 U.S.C. § 706. *Pride Mobility Prods. Corp. v. Permobil, Inc.*, 818 F.3d 1307, 1313 (Fed. Cir. 2016). We set aside the agency’s actions if they are “arbitrary, capricious, an abuse of discretion, or otherwise not in accordance with law” or “unsupported by substantial evidence.” 5 U.S.C. § 706(2). We review its legal conclusions de novo and its factual findings for substantial evidence. *In re Gartside*, 203 F.3d 1305, 1316 (Fed. Cir. 2000). A finding is supported by substantial evidence if a reasonable mind might accept the evidence as adequate support for the finding. *Consol. Edison Co. v. NLRB*, 305 U.S. 197, 229 (1938).

Right of Appeal Notice in the merged King/Apple reexamination but mistakenly identified that claim as being objected to on the cover page. The Board adopted this mistake and, therefore, omitted claim 36 from its review of the Examiner’s rejections. Both parties acknowledge the oversight. We therefore instruct the PTO to correct the record to reflect that claim 36 stands rejected prior to issuing the reexamination certificate.

I. Affinity's Petition to Terminate

We first address Affinity's argument that the PTO improperly maintained all three reexaminations over the estoppel provision of pre-AIA 35 U.S.C. § 317(b). Affinity argues that § 317(b) requires the PTO to terminate the Volkswagen reexamination in its entirety after Volkswagen received an adverse ruling as to the asserted claims—claims 28 and 35—in the co-pending litigation. Affinity also argues that because the Volkswagen reexamination was merged with the Apple and King reexaminations into a single proceeding at the time—and the parties were permitted to comment on proposed grounds of unpatentability that were not advanced in their respective petitions—the PTO's decision not to terminate the entire merged proceeding was error. Affinity does not tie this argument to the language of the statute but argues the decision not to terminate all reexaminations frustrates section 317(b)'s underlying policy goal of preventing duplicative, harassing actions. We conclude that a straightforward reading of the plain language of section 317(b) precludes Affinity's overly broad conception of the estoppel provision. We, therefore, find no grounds to reverse the Board's final decisions based on section 317(b).

In order to further encourage parties to use the PTO's patent reexamination procedure, Congress enacted in 1999 *inter partes* reexamination "as an option to the existing *ex parte* reexamination proceedings." 145 Cong. Rec. 29,972 (1999). With *inter partes* reexamination, Congress hoped, as it had when it enacted *ex parte* reexamination years earlier, to "reduce litigation in district courts and make reexamination a viable, less costly alternative to patent litigation." 145 Cong. Rec. 26,984 (1999) (statement of Sen. Hatch). In contrast to *ex parte* reexamination, Congress specifically provided the third party reexamination requester the opportunity to fully

participate in the *inter partes* proceeding. *See generally* 35 U.S.C. § 311 *et seq.* (pre-AIA).

In addition to allowing requester participation in *inter partes* reexamination, Congress enacted measures in the *inter partes* reexamination statute to “prevent abusive reexamination requests, including broad estoppel provisions.” 145 Cong. Rec. 26,984 (1999) (statement of Sen. Hatch). Those provisions are reflected, in part, in 35 U.S.C. § 317 (the pre-AIA version), entitled “Inter partes reexamination prohibited,” which limits an *inter partes* reexamination requester’s ability to continually attack the validity of a patent’s claims by using the *inter partes* reexamination process. Section 317(a), for example, generally prohibits an *inter partes* reexamination requester, whose reexamination request has been granted and the proceeding on that patent is pending, from filing “a subsequent request for *inter partes* reexamination of the patent” until the first *inter partes* reexamination has been completed and a reexamination certificate issues. Section 317(b) bars a party from using the *inter partes* reexamination process after a final decision has been entered against that party in a civil action, finding “that the party has not sustained its burden of proving the invalidity of any patent claim in suit.” The statute provides in pertinent part:

Once a final decision has been entered against a party in a civil action . . . that the party has not sustained its burden of proving the invalidity of any patent claim in suit or if a final decision in an *inter partes* reexamination proceeding instituted by a third-party requester is favorable to the patentability of any original or proposed amended or new claim of the patent, then neither that party nor its privies may thereafter request an *inter partes* reexamination of any such patent claim on the basis of issues which that party or its privies raised or could have raised in such civil action or

inter partes reexamination proceeding, and an inter partes reexamination requested by that party or its privies on the basis of such issues may not thereafter be maintained by the Office

35 U.S.C. § 317(b) (pre-AIA).³

A few notable features of the *inter partes* reexamination statutory estoppel provision stand out from its plain language: (1) it applies to the party in the civil action that loses its validity attack against “any patent claim” as well as the party’s privies; (2) it applies to validity issues raised in the civil action or that could have been raised in that action; (3) unlike section 317(a), it speaks in terms of any “patent claim,” as opposed to the “patent;” (4) it prohibits the losing party and its privies from requesting an *inter partes* reexamination “of any such patent claim;” and (5) “on the basis of such issues,” it prohibits the PTO from “maintain[ing]” any *inter partes* reexamination requested by the losing party.

Affinity urges that we order the PTO to terminate all three reexamination proceedings—even though they involve several claims beyond the litigated claims 28 and 35, the other *inter partes* reexamination requester had no involvement or relationship to that prior litigation, and the third proceeding was an *ex parte* reexamination—based on its reading of section 317(b). The PTO offers a counter reading of this statutory estoppel provision, which

³ Although section 317(b) estops parties who have received a final adverse decision in either a civil action or an *inter partes* reexamination, for convenience our discussion focuses on how the estoppel provision operates when a party receives a final adverse decision in a civil action. Our analysis and conclusion, however, is equally relevant in both situations.

follows its established practice set forth in Manual of Patent Examining Procedure (MPEP) § 2686.04(V)(A).

“Our first step in interpreting a statute is to determine whether the language at issue has a plain and unambiguous meaning with regard to the particular dispute in the case. Our inquiry must cease if the statutory language is unambiguous and the statutory scheme is coherent and consistent.” *Pennzoil–Quaker State Co. v. United States*, 511 F.3d 1365, 1373 (Fed. Cir. 2008) (quoting *Robinson v. Shell Oil Co.*, 519 U.S. 337, 340 (1997)). “Absent a clearly expressed legislative intention to the contrary, [the statute’s plain] language must ordinarily be regarded as conclusive.” *Wyeth v. Kappos*, 591 F.3d 1364, 1369 (Fed. Cir. 2010) (quoting *Consumer Prod. Safety Comm’n v. GTE Sylvania, Inc.*, 447 U.S. 102, 108 (1980)) (alteration in original). Moreover, “statutory language cannot be construed in a vacuum. It is a fundamental canon of statutory construction that the words of a statute must be read in their context and with a view to their place in the overall statutory scheme.” *Davis v. Mich. Dep’t. of Treasury*, 489 U.S. 803, 809 (1989).

The crux of Affinity’s argument is that the statute operates differently and has a much broader impact against a losing party’s active, pending *inter partes* reexamination compared to a losing party’s request for an *inter partes* reexamination. According to Affinity, if a patent challenger conclusively loses its validity challenge in court against, say, claims 1–5 of a 20-claim patent, section 317(b) prevents that party from requesting an *inter partes* reexamination on just claims 1–5 (and not claims 6–20) of that patent on issues that had been raised or could have been raised in the civil action. No one disagrees there. But, in Affinity’s view, section 317(b) requires termination of a pending *inter partes* reexamination that had been requested by the losing party, regardless of which claims of the patent are being reexamined in the proceeding: it could be claims 1–10, or 1–20, or even 6–20. For Affinity

then, the scope of the statutory estoppel is claim-specific as to requests for *inter partes* reexamination, but is purely patent-as-a-whole-driven for maintaining a pending *inter partes* reexamination. We disagree with Affinity's proposed interpretation and instead see the estoppel provision's claim-based approach applying in the same way to both a request for *inter partes* reexamination and the maintenance of a pending *inter partes* reexamination.

The structure of pre-AIA section 317(b) contemplates a parallel and consistent approach to limiting a party's ability to request a reexamination and to maintain a reexamination once a final decision has been entered against the party in a civil action. The statute first explains that the party may not request reexamination on "any such patent claim on the basis of issues which that party or its privies raised or could have raised in such civil action." This language limits the scope of estoppel in two ways: (i) to the specific claims that were actually at issue in the district court proceeding; and (ii) to challenges to *those* claims that were raised or could have been raised. In other words, the "issues that could have been raised" are necessarily bounded by the preceding reference to "any such patent claim." When the statute subsequently prohibits maintaining a reexamination "on the basis of *such* issues," the issues in question are similarly bounded by the "any such patent claims" limitation. If Congress had intended the statutory estoppel provision to apply in a different, broader, patent-based way for pending *inter partes* reexaminations (and we see nothing in the legislative history suggesting such an intent), it understood how to do so, as it did for the subsection immediately preceding section 317(b). As explained above, in section 317(a), a party who has already triggered a still-pending *inter partes* reexamination of a patent's claims may not file "a subsequent request for *inter partes* reexamination of the patent" until a reexamination certificate issues for the pending proceeding.

Moreover, the *inter partes* reexamination statutory scheme consistently reflects a careful, express focus on implementing this regime on a claim-by-claim basis. Section 311 requires an *inter partes* reexamination requester to “set forth the pertinency and manner of applying cited prior art to every *claim* for which reexamination is requested.” 35 U.S.C. § 311(b)(2) (pre-AIA) (emphasis added). Under section 312, “the Director shall determine whether a substantial new question of patentability affecting any *claim* of the patent concerned is raised by the request.” *Id.* § 312 (emphasis added). Furthermore, “[i]f . . . the Director finds that a substantial new question of patentability affecting a *claim* of a patent is raised, the determination shall include an order for *inter partes* reexamination of the patent for resolution of *the question*.” *Id.* § 313 (emphasis added). In other words, the order to conduct an *inter partes* reexamination is to resolve the patentability questions of particular claims specifically raised by a requester—not an entire patent—once a substantial new question of patentability is raised for those selected patent claims. Had Congress wanted the *inter partes* reexamination to extend to all claims of a patent, regardless of how many claims were requested for review, it would have left out the final phrase “resolution of the question” and ended the provision with “an order for *inter partes* reexamination of the patent.”

In addition, this claim-by-claim focus is also reflected in the converse estoppel provision that prohibits a challenge to a patent claim which has been finally determined to be valid in an *inter partes* reexamination proceeding. Section 315 provides:

A third-party requester whose request for an *inter partes* reexamination results in an order under section 313 is estopped from asserting at a later time, in any civil action arising in whole or in part under section 1338 of title 28, the invalidity of any *claim* finally determined to be valid and patentable.

ble on any ground which the third-party requester raised or could have raised during the *inter partes* reexamination proceedings.

35 U.S.C. § 315(c) (pre-AIA) (emphasis added). Thus, as with section 317(b), the statute in section 315(c) similarly estops the requester from challenging again, in a different venue, the validity of claims that were actually decided against the requester. Nothing in section 315(c), however, estops the requester from challenging at a later time the validity of a claim that was not previously requested pursuant to section 311 and reexamined pursuant to section 313.

Upon review of the text, structure, and history of the *inter partes* reexamination statute, we decline to read section 317(b) in an incongruous way that would cause the statutory estoppel provision to apply differently for requesting an *inter partes* reexamination compared to maintenance of a pending *inter partes* reexamination. Such a reading would require us to read a patent-based assumption into a portion of that provision where there is none and Affinity offers no reason why one would exist. We, therefore, conclude that section 317(b) plainly limited the scope of estoppel in all circumstances to only those *claims* actually challenged and for which the requesting party received an adverse final decision in the district court proceeding. Congress could have mandated that any challenge to any claim in a patent in an *inter partes* reexamination would be estopped once a validity challenge to one or more claims of the patent had been rejected in a prior proceeding, yet it did not do so. Rather, Congress chose to estop only further validity challenges—using *inter partes* reexamination—to the specific claims the validity of which had been previously resolved against the requester. As such, we reject Affinity’s argument that the PTO was required to terminate the Volkswagen reexamination with respect to all claims in that reexamination. We instead affirm the PTO’s decision to termi-

nate that reexamination as to only the claims in which a final decision in the civil action has been entered—claims 28 and 35.

We also find no basis in the statute for Affinity’s argument that the final decision in the Volkswagen litigation should have preclusive effect on the reexaminations requested by King or Apple. By its plain and unambiguous terms, pre-AIA section 317(b) extends only to *inter partes* reexaminations—not *ex parte* reexaminations. The estoppel effect of the statute, therefore, has no bearing on the *ex parte* King reexamination. Moreover, the statute also imposes the aforementioned limitations only on a requester that was a party to the civil action or its privies. Because Apple was neither a party to the Volkswagen litigation nor was there any evidence Apple was Volkswagen’s privy, we also find no error in the PTO’s decision not to terminate the *inter partes* reexamination requested by Apple.

Affinity’s invocation of the general policy goal of preventing abusive reexamination practices cannot override the statute. “It is a bedrock canon of statutory construction that our judicial inquiry ends where statutory language is plain and unambiguous.” *Pfizer, Inc. v. Lee*, 811 F.3d 466, 471 (Fed. Cir. 2016) (quoting *White v. United States*, 543 F.3d 1330, 1337 (Fed. Cir. 2008)). “[O]nly a ‘most extraordinary showing of contrary intentions’ by Congress justifies a departure from the plain language of a statute.” *Wyeth*, 591 F.3d at 1371 (quoting *Garcia v. United States*, 469 U.S. 70, 75 (1984)). The plain language of the statute does not permit extending the reach of estoppel as far as Affinity suggests. Moreover, we have reviewed the legislative history and find no such extraor-

dinary showing sufficient to overcome the statute's plain language.⁴

In sum, Affinity has failed to demonstrate that the PTO's denial of its petitions to vacate the entire merged proceeding was arbitrary, capricious, an abuse of discretion, or otherwise not in accordance with law.⁵

⁴ We also find meritless Affinity's argument that by merging the proceedings the PTO "effectively created an *inter partes* review." Affinity Opening Br. at 25. Affinity provides no statutory, regulatory, or rule-based support for its allegation, nor can we comprehend how it could do so, given the PTO merged the proceedings on June 14, 2010—more than two years before *inter partes* review was established. We are also unaware of any justification supporting Affinity's suggestion that the PTO's *sua sponte* decision to merge the proceedings somehow modifies the scope of the statutory estoppel applied against the requester.

⁵ We reject the Director's alternative argument that dismissal of Affinity's petitions to terminate the reexaminations was not a "final" agency action pursuant to the Manual of Patent Examining (MPEP) § 1002.02 ("A dismissal of a petition, a denial of a petition without prejudice, and other interlocutory orders are not final agency action."). To the extent the Director argues the refusal to terminate the proceeding under section 317(b) is unreviewable under 5 U.S.C. § 704, we have previously held that such a decision is reviewable once the Board issues a decision on the merits. *See Automated Merchandising Sys., Inc. v. Lee*, 782 F.3d 1376, 1381 (Fed. Cir. 2015). We also reject the Director's argument that Affinity was required to first seek reconsideration under the circumstances of this case. There was no indication in the PTO dismissal of Affinity's petitions that further action was required by Affinity to receive the PTO's final an-

II. Unpatentability of the '833 Patent

We next address Affinity's arguments that the Board erred in upholding the Examiner's unpatentability rejections in both decisions. We conclude that substantial evidence supports the Board's unpatentability findings as to all challenged claims in the merged King/Apple reexamination. Because the claims at issue in the Volkswagen reexamination comprise only a subset of the claims in the King/Apple reexamination, we do not address the alternative grounds of unpatentability at issue in the Volkswagen reexamination appeal.

A. Anticipation by Dwyer

Affinity appeals the Board's decision in the King/Apple reexamination that claims 1–27, 39, and 45 are anticipated by Dwyer or obvious over Dwyer in view of additional secondary references. Affinity argues specifically that Dwyer does not disclose (i) a portable electronic device configured to display a graphical interface item, having “a name associated with an audio file saved in memory,” as required by independent claim 1; or (ii) “a plurality of preprogrammed soft buttons that are linked to respective audio information sources,” as required by

swer. Indeed, the PTO's dismissal—a fifteen-page decision from the Office of Patent Legal Administration—had all the hallmarks of a final action marking the consummation of the agency's decision-making process. In that decision, the PTO did not reference MPEP § 1002.02, nor did it inform Affinity that it was required to seek reconsideration in the dismissal. We, therefore, think it would be unnecessary to have required Affinity to have done more.

independent claims 1 and 17.⁶ We find both of Affinity’s arguments unpersuasive.

A claim is unpatentable as anticipated “if each and every limitation is found either expressly or inherently in a single prior art reference.” *King Pharm., Inc. v. Eon Labs, Inc.*, 616 F.3d 1267, 1274 (Fed. Cir. 2010) (citation omitted). Anticipation is a question of fact we review for substantial evidence. *REG Synthetic Fuels, LLC v. Neste Oil Oyj*, 841 F.3d 954, 958 (Fed. Cir. 2016).

⁶ Affinity did not argue to the Board that the dependent claims were separately patentable and it does not argue the claims separately on appeal. We consider Affinity’s argument with respect to independent claims 1 and 17 as dispositive of all rejections based on Dwyer. See 37 C.F.R. § 41.37(c)(1)(iv) (2012) (“For each ground of rejection applying to two or more claims, the claims may be argued . . . as a group (all claims subject to the ground of rejection rise and fall together)”); *In re Kaslow*, 707 F.2d 1366, 1376 (Fed. Cir. 1983) (“Since the claims are not separately argued, they all stand or fall together.”) (citation omitted).

Dwyer generally relates to the field of portable digital recorders and the “effective and convenient interaction between a portable digital recorder and a personal computer.” Dwyer col. 1, ll. 36–38. Figure 1 shows the general configuration disclosed in Dwyer, whereby a digital portable recorder 12 is physically connected, by way of a cradle 14 and a cable 15 to a personal computer 16 (*see id.* col. 3, ll. 18–24):

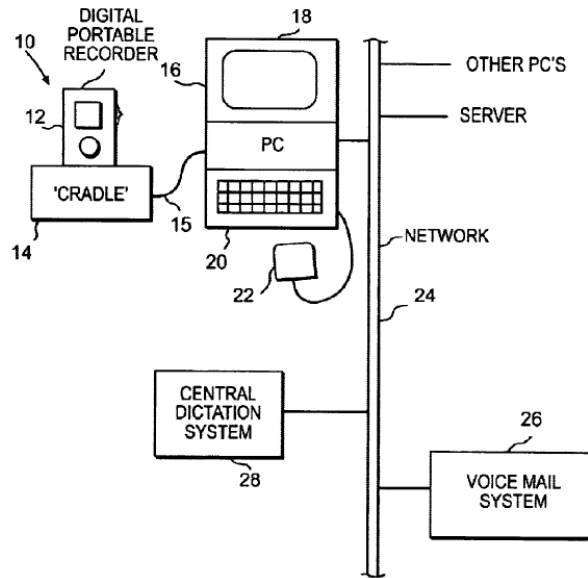

FIG. 1

Dwyer’s recorder stores digital audio files and includes a touch screen that “provides information to the user of the recorder, and through which the user inputs information.” *Id.* col. 4, ll. 41–42. Dwyer discloses a variety of touch screen functions and notes that “it is contemplated to allow the user to control recording, editing and playback functions via the touch screen, which also may be used to navigate among voice files and to select an existing voice file for playback and/or additional recording.” *Id.* col. 4, l. 66 – col. 5, l. 3; col. 6, ll. 10–12. Dwyer also discloses that “[r]ecorded with, or other-

wise associated with, each voice file is header data,” *id.* col. 5, ll. 16–17, as shown in Figure 5:

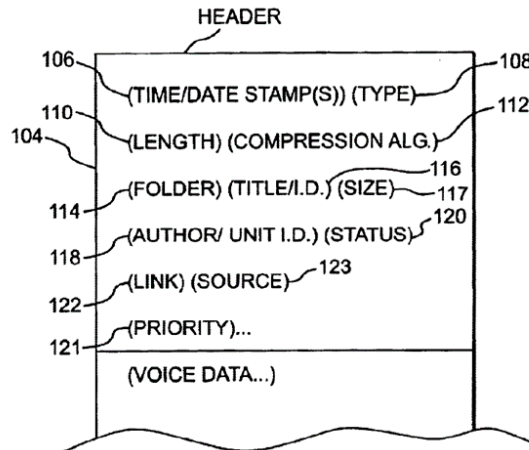

FIG. 5

That header information includes, specifically, “title or other identifying data 116, which indicates a title or other name used to identify the corresponding voice file.” *Id.* col. 5, ll. 31–32.

Given the disclosure above, the Board was reasonable to conclude that Dwyer’s portable electronic device necessarily displays name information on the graphical interface to allow the user to meaningfully navigate the digital files stored on the device. Substantial evidence supports the Board’s finding that this limitation is disclosed by Dwyer.

Dwyer also teaches communicating information from the portable recorder device to the user’s personal computer. Specifically, the Dwyer system contemplates that the recorder “uploads to the personal computer voice file identification data corresponding to all of the voice files (i.e. the portion of the header data indicated as ‘title/I.D.’ data 116 and discussed above in connection with FIG. 5).” *Id.* col. 6, ll. 24–28. That header data is used to create a

graphical user interface display on the user's personal computer, indicative of the files stored in the recorder. In this way, the user can view and manipulate information stored on the recorder via the graphical user interface displayed on the personal computer.

Dwyer specifically discloses that information, including a name, associated with audio files is displayed in the graphical user interface for selection and playback by the user. *Id.* col. 6, ll. 24–36. Figure 8 depicts the information presented through the computer screen's display:

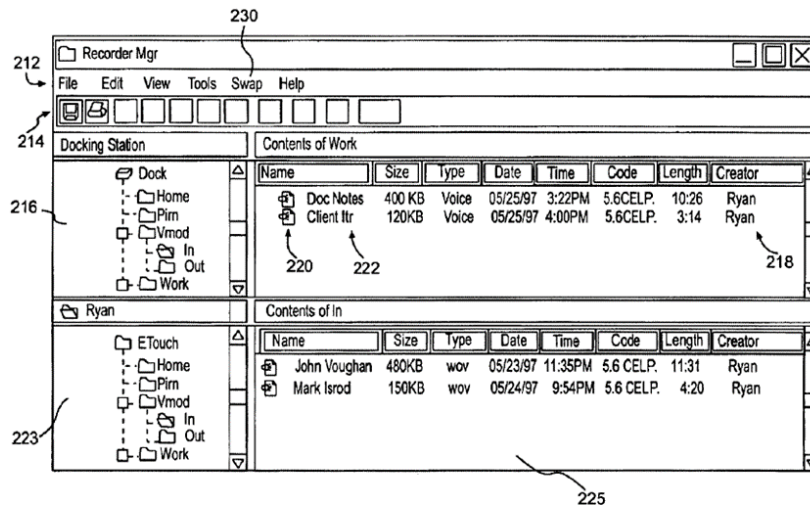

FIG. 8

“Field 218 allows the user to focus in on particular voice files in the recorder,” *id.* col. 8, ll. 34–35, “[i]cons 220 in field 218 are each respectively indicative of a voice file stored in the portable recorder,” *id.* col. 8, ll. 35–37, and “[n]ame information indicated at 222 corresponds to the header data component 116 (FIG. 5) for the voice files, which was uploaded to the PC” *Id.* col. 8, ll. 37–39. When the user attempts to access information stored in the portable recorder via the graphical user interface, Dwyer explains, “the specific file may be selected, for example, by designating the corresponding icon in the field 218 of the display of FIG. 8.” *Id.* col. 9, ll. 6–9.

Based on this disclosure, the Board's finding that Dwyer teaches soft buttons (comprised of the icon 220 and name 222 information found in field 218) linked to respective audio information sources (as stored in the portable digital recorder) is eminently reasonable. We, therefore, conclude that substantial evidence supports the Board's finding that claims 1–27, 39, and 45 are unpatentable based on the asserted Dwyer rejections.

B. Obviousness Based on Naim and Lee

Affinity also appeals the Board's obviousness conclusion as to claims 1–26, 37–42, and 45–46 in view of the combination of Naim and Lee. Affinity argues that neither Naim nor Lee discloses (i) communicating a graphical item comprising a name from a portable electronic device to a different electronic device, as required by claims 1 and 17; or (ii) a portable electronic device with a mounting location that includes a physical interface, as required by claims 1, 23, and 24.⁷ Affinity further argues that the Board improperly rejected its objective indicia of nonobviousness evidence. We disagree with Affinity's challenges to the disclosures of Naim and Lee and conclude that substantial evidence supports the Board's decision not to give dispositive weight to Affinity's objective indicia argument.

A claim is unpatentable if the differences between the claimed subject matter and the prior art are such that the subject matter as a whole would have been obvious at the time the invention was made to a person having ordinary

⁷ Because Affinity does not separately argue the rejected dependent claims, with the exception of claims 23 and 24, those claims rise and fall with the independent claims.

skill in the art. 35 U.S.C. § 103;⁸ *KSR Int'l Co. v. Teleflex Inc.*, 550 U.S. 398, 406 (2007). Obviousness is a question of law based on underlying findings of fact. *Harmonic Inc. v. Avid Tech., Inc.*, 815 F.3d 1356, 1363 (Fed. Cir. 2016). The underlying findings of fact include the scope and content of the prior art, the differences between the prior art and the claimed invention, whether there is a motivation to combine prior art references, the level of ordinary skill in the art, and relevant secondary considerations. *Merck & Cie v. Gnosis S.P.A.*, 808 F.3d 829, 833 (Fed. Cir. 2015), *cert. denied*, 137 S. Ct. 297 (2016).

⁸ Congress amended § 103 when it passed the Leahy–Smith America Invents Act (“AIA”). Pub. L. No. 112–29, § 3(c), 125 Stat. 284, 287 (2011). However, because the application that led to the ’833 patent has never contained a claim having an effective filing date on or after March 16, 2013 (the effective date of the statutory changes enacted in 2011), or a reference under 35 U.S.C. §§ 120, 121, or 365(c) to any patent or application that ever contained such a claim, the pre-AIA § 103 applies. *Id.* § 3(n)(1), 125 Stat. at 293.

Naim relates to the field of portable digital devices and specifically teaches a system where recorded audio files can be transferred from a portable electronic device to a different electronic device. Naim col. 11, ll. 17–22. Figure 1B depicts Naim’s system as follows:

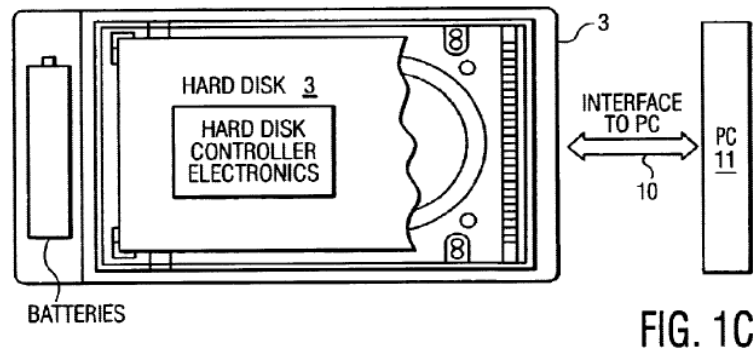
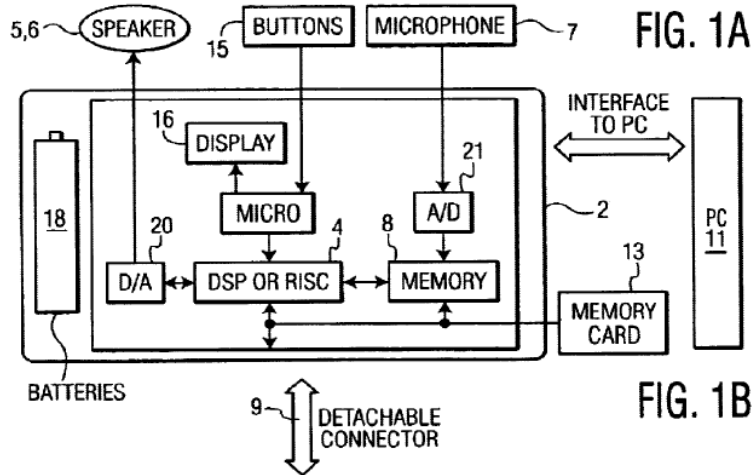

Naim’s portable device comprises two main parts, the portable player 2 and the hard drive 3. *Id.* col. 5, ll. 4–5. Naim explains that “control buttons 15 on the portable device 1 allow for operation of the player 2 and its interface with the hard disk 3 via an interface 9, which can be a physical hard connector or a wireless interface.” *Id.* col. 5, ll. 21–24. In addition, the portable device “can also have an interface 10 to allow data-file download/upload

from an external communications device 11, such as a PC, to the portable device hard disk 3.” *Id.* col. 5, ll. 24–27.

Lee discloses an Internet radio system that can be incorporated into a car. The Lee system uses a multimedia device with a graphical user interface in an automobile that can interact with portable devices such as notebook computers, cellular phones, and MP3 players. Lee col. 5, ll. 47–65; col. 7, ll. 55–61; col. 8, ll. 47–64. As depicted in Figure 2 below, the Lee multimedia device includes a display to present audio information to the user via the graphical user interface.

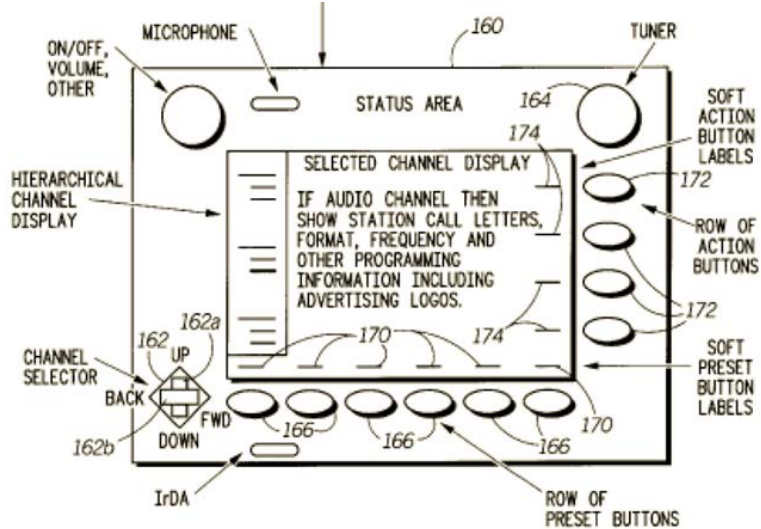

FIG. 2

The display includes soft buttons that a user can manipulate to play audio files stored on a portable device. *Id.* col. 10, ll. 23–27.

Affinity first contends that the Board erred in concluding Naim discloses a portable electronic device graphical interface item comprising a name because the only transfer of data in Naim from the portable device to a PC “is either . . . statistical information or voice recorded content,” and “[t]his information need not include identi-

fyng information.” Affinity Opening Br. 45. We disagree. First, Naim contemplates bi-directional transfer of information between the two devices via interface port 10. Moreover, “[i]f the portable handheld audio device is used as a recorder, this port can be used to upload the recorded content to the computer.” *Id.* col. 11, ll. 20–22. That uploaded content is stored in memory as a digital data file and would necessarily include identifying information such as file name. From this, it was reasonable for the Board to find that Naim discloses communicating the claimed information from the portable electronic device 2 to the external communications device, PC 11. We therefore conclude substantial evidence supports the Board’s finding that this limitation is disclosed by Naim.

We next address Affinity’s argument that the Board erred in finding that Lee teaches a “mounting location . . . that includes a physical interface.” Affinity contends that, properly construed, this phrase excludes wireless coupling. And, according to Affinity, Lee teaches only wireless communication. We, like the Board, reject Affinity’s narrow construction. The Board adopted the Examiner’s interpretation of the claimed physical interface to comprise any circuitry or the like on or within a device that allows it to communicate wirelessly or via a wire. It also endorsed the Examiner’s construction of “mounting location” as any location on or within the portable device in which the physical interface is installed or mounted. We agree with the Examiner that neither the express language of the claim nor the specification precludes a wireless interface formed by physical components having a mounting location on the portable device. *See In re Rambus, Inc.*, 753 F.3d 1253, 1255 (Fed. Cir. 2014) (noting that, during reexamination, the Board must construe claims giving them their broadest reasonable interpretation consistent with the specification). Under the broadest reasonable interpretation, substantial evidence supports the Board’s finding that Lee teaches the claimed

“mounting location . . . that includes a physical interface.” Moreover, the Examiner also expressly found “Naim’s portable player is capable of communicating to a PC either wirelessly or via a wire.” J.A. 10643. Indeed, Naim discloses that the interface between the two devices “can be a physical hard connector or a wireless interface.” Naim col. 5, ll. 24–28. Thus, even applying Affinity’s narrow construction, substantial evidence supports the Board’s finding that the combination of Naim and Lee discloses the claimed physical interface.

Finally, we are not persuaded that the Board erred in its analysis of Affinity’s proffered objective indicia of nonobviousness. Affinity pointed to (i) a \$25 billion industry developed around in-vehicle device integration, which it says is covered by the claims of the ’833 patent; and (ii) Affinity’s licensing of the ’833 patent and its siblings to a number of entities in excess of \$50 million. Upon review, however, we agree with the Examiner that this evidence, at best, establishes a tenuous connection with the claimed invention.

Evidence of commercial success is only relevant to the obviousness inquiry “if there is a nexus between the claimed invention and the commercial success.” *Ormco Corp. v. Align Tech., Inc.*, 463 F.3d 1299, 1312 (Fed. Cir. 2006). There is no nexus unless the evidence presented is “reasonably commensurate with the scope of the claims.” *See Rambus Inc. v. Rea*, 731 F.3d 1248, 1257 (Fed. Cir. 2013). Here, the Board correctly recognized that Affinity provided no explanation or analysis that corroborates the relationship between the claims of the ’833 patent and the market for in-vehicle device integration technology generally. Affinity’s argument that the claims of the ’833 patent are directed to the general field of device connectivity and interoperability, without more, does not establish a meaningful connection with the asserted commercial success. We, therefore, see no error in the Board’s decision that this evidence of nonobviousness was

entitled to little weight. *See Pro-Mold & Tool Co. v. Great Lakes Plastics, Inc.*, 75 F.3d 1568, 1574 (Fed. Cir. 1996) (“It is within the province of the fact-finder to resolve these factual disputes regarding whether a nexus exists between commercial success of the product and its patented features, and to determine the probative value of . . . evidence of secondary considerations . . .”).

Moreover, the mere fact of licensing alone cannot be considered strong evidence of nonobviousness if it cannot also be shown that the licensees did so out of respect for the patent rather than to avoid the expense of litigation. *See Iron Grip Barbell Co. v. USA Sports, Inc.*, 392 F.3d 1317, 1324 (Fed. Cir. 2004) (“Our cases specifically require affirmative evidence of nexus where the evidence of commercial success presented is a license, because it is often ‘cheaper to take licenses than to defend infringement suits.’”). To support its licensing argument, Affinity did not enter the actual licenses into the record but, rather, submitted the unsupported declaration of Affinity’s President that it “has generated revenues of over \$50,000,000 for licensing the ’833 patent *and related patents.*” J.A. 10488 (emphasis added). Affinity did not explain what percentage of this revenue—if any—was attributed to the ’833 patent instead of the related patents, the terms of the licenses, the nature and number of other patents at issue in the licenses, or the circumstances under which they were granted, except to concede that some “were entered as part of settlement of pending lawsuits.” *Id.* This court has explained that, as here, “[w]hen the specific licenses are not in the record, it is difficult for the court to determine if ‘the licensing program was successful either because of the merits of the claimed invention or because they were entered into as business decisions to avoid litigation, because of prior business relationships, or for other economic reasons.’” *In re Cree, Inc.*, 818 F.3d 694, 703 (Fed. Cir. 2016) (quoting *In re Antor Media Corp.*, 689 F.3d 1282, 1294 (Fed. Cir.

2012)). Because of the lack of specificity in Affinity's licensing argument, the Board correctly afforded this evidence little weight.

CONCLUSION

For the foregoing reasons, we affirm the -4281 Board Decision that claims 1–27, 37–42, and 45–46 are unpatentable. Because claim 36 was rejected by the Examiner and Affinity has made no independent argument that claim 36 was improperly rejected apart from those arguments made with respect to the independent claims, we remand to the Board for the limited purpose of correcting the record to reflect that claim 36 is rejected as unpatentable before issuing a reexamination certificate. Because we affirm the -4281 Board Decision, we need not resolve Affinity's appeal relating to the -6122 Board Decision upholding the unpatentability of claims 1–5, 8–20, and 22–27, and dismiss that appeal as moot.

**AFFIRMED-IN-PART, REMANDED-IN-PART,
DISMISSED-IN-PART**

COSTS

No costs.