

NOTE: This disposition is nonprecedential.

**United States Court of Appeals  
for the Federal Circuit**

---

**ICON HEALTH & FITNESS, INC., A DELAWARE  
CORPORATION,**  
*Plaintiff-Appellant*

v.

**POLAR ELECTRO OY, A FINNISH COMPANY,  
POLAR ELECTRO INC., A DELAWARE  
CORPORATION,**  
*Defendants-Appellees*

---

2015-1891

---

Appeal from the United States District Court for the  
District of Utah in No. 1:11-cv-00167-BSJ, Senior Judge  
Bruce S. Jenkins.

-----  
**ICON HEALTH & FITNESS, INC., A DELAWARE  
CORPORATION,**  
*Plaintiff-Appellant*

v.

**GARMIN INTERNATIONAL, INC., A KANSAS  
CORPORATION, GARMIN USA, INC., A KANSAS**

**CORPORATION,**  
*Defendants-Appellees*

**GARMIN LTD., A SWISS CORPORATION,**  
*Defendant*

---

2016-1166

---

Appeal from the United States District Court for the District of Utah in No. 1:11-cv-00166-RJS, Judge Robert J. Shelby.

---

Decided: August 8, 2016

---

ROBERT PARRISH FREEMAN, JR., Maschoff Brennan P.L.L.C., Park City, UT, argued for plaintiff-appellant. Also represented by LARRY R. LAYCOCK, JARED J. BRAITHWAITE, DAVID R. WRIGHT, Salt Lake City, UT.

JOHN P. MORAN, Holland & Knight, LLP, Washington, DC, argued for defendants-appellees Polar Electro OY, Polar Electro Inc. Also represented by ANTHONY J. FUGA, Chicago, IL.

ADAM PRESCOTT SEITZ, Erise IP, P.A., Overland Park, KS, for defendants-appellees Garmin International, Inc., Garmin USA, Inc. Also represented by MEGAN JOANNA REDMOND.

---

Before NEWMAN, MOORE, and O'MALLEY, *Circuit Judges*.  
O'MALLEY, *Circuit Judge*.

Icon Health & Fitness, Inc. (“Icon”) appeals the final judgment of the district court finding the claims of U.S. Patent No. 6,921,351 (“the ’351 patent”) indefinite, and therefore invalid. *Icon Health & Fitness, Inc. v. Polar Electro Oy*, No. 1:11-CV-00167-BSJ, 2015 WL 2376056 (D. Utah May 18, 2015). The district court found the claim terms “in-band,” “out-of-band,” and “relationship” to be “ambiguous and incapable of construction,” concluding that the claims containing these terms “fail to inform, with reasonable certainty, those skilled in the art about the scope of the invention.” *Id.* at \*12 (citation and internal quotation mark omitted). Icon also appeals the final judgment in a separate case in the same district dismissing the claims involving the ’351 patent as barred by the doctrine of issue preclusion. *Icon Health & Fitness, Inc. v. Garmin Int’l*, No. 1:11-CV-166-RJS, 2015 WL 5714248 (D. Utah Sept. 29, 2015). Because the district court did not err in its analysis, we *affirm*.

## BACKGROUND

### A. The ’351 Patent

The ’351 patent discloses an exercise and health system that is capable of providing feedback and encouragement to the user (simulating the function of a personal trainer) and networking devices together to simulate a group setting.

The present invention provides an exercise and health system which is convenient, affordable, and effective. The system includes computerized exercise and/or health equipment (the “local system”) that can provide feedback and encouragement to the user, i.e., serve as a “virtual personal trainer.” These local systems often include a local server to service multiple exercise devices. In addition, the system includes a remote system communicating over a bi-directional data channel (preferably the Internet) with the exercise and

health equipment. This remote system can include remote servers communicating with the local system, and remote work stations used by trainers and users to interact with the remote servers and local systems.

'351 patent, col. 2 ll. 23–34. The '351 patent has 20 claims. The allegedly ambiguous terms are found in independent claims 1 and 5, reproduced here:

1. An exercise system comprising:

a local system including at least one exercise apparatus and at least one associated local server, said at least one local server monitoring the operation of said at least one exercise apparatus, said exercise apparatus and said local server having an *in-band* communication using a bid-directional [sic] wireless protocol;

an *out-of-band* communication with a user of said at least one exercise apparatus, wherein said *out-of-band* communication has a *relationship* to said *in-band* communication;

a remote server; and

wherein said local server and said remote server include communication interfaces which permits communication over a packet network connection that at least part-time couples said local server to said remote server for data communication between said local server and said remote server, such that said remote system may receive local system data from said local server concerning said operation of said exercise apparatus, and such that said local system may receive remote server data from said remote server providing feedback concerning said operation of said exercise apparatus.

'351 patent, claim 1 (emphases added on claim terms at issue).

5. An exercise system comprising:

at least one exercise apparatus having an *in-band* bi-directional wireless communication device;

an *out-of-band* communication device capable communication with a user of said at least one apparatus that has a *relationship* to said *in-band* communication;

at least one associated local server having a bi-directional wireless communication device such that said exercise apparatus and said local server may communicate with each other via a wireless connection; and

at least one remote server in communication with said local server via, at least in part, an Internet connection, said remote server at least temporarily storing information concerning exercise sessions performed on said exercise apparatus.

'351 patent, claim 5 (emphases added on claim terms at issue).

Figure 1 of the patent demonstrates the computer network exercise system:

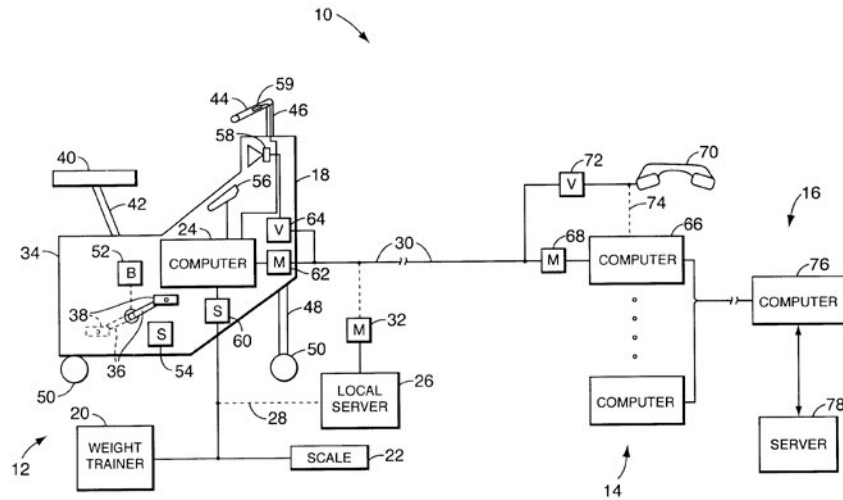

'351 patent, Figure 1. "In Figure 1, a computer 24 in bicycle 18 is connected by a line 30 (which can be the Internet) to a remote computer 66, which is connected to server station 16." *Icon Health & Fitness, Inc.*, 2015 WL 2376056 at \*1 (citing '351 patent, col. 7 ll. 33–37; col. 8 ll. 14–16). Figure 1 demonstrates the local system 12, located on the left side of the figure, with the remote system 14 on the right. The local system 12 "can provide feedback and encouragement to the user, i.e. can serve as a 'virtual personal trainer.'" *Id.* (quoting '351 patent, col. 2, ll. 23–27). This figure does not distinguish between "in-band" and "out-of-band" communications, but does demonstrate the nature of the technology at issue: an exercise apparatus with, at least, a local computer, a remote computer, and a means of communication between them.

Figure 14, on the other hand, demonstrates the in-band and out-of-band communications:

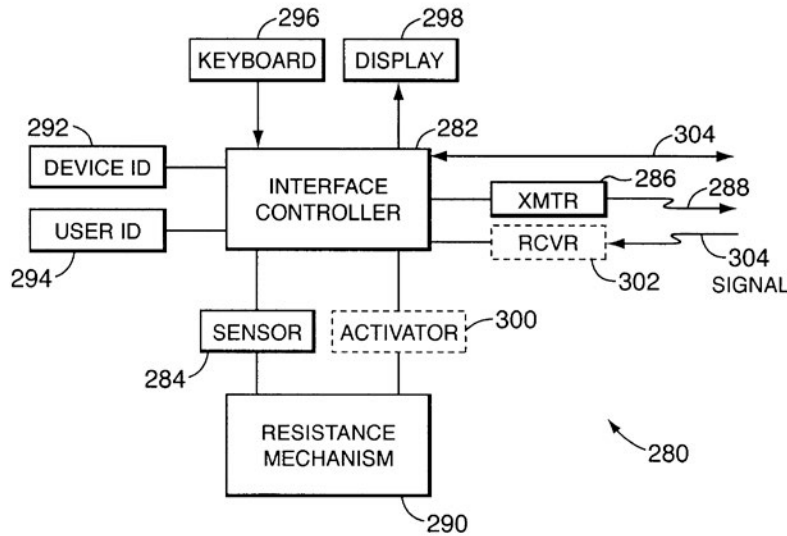

FIG. 14

'351 patent, Figure 14. This figure illustrates “a block diagram of an exercise circuit which can be associated with, for example, an exercise device.” *Id.* at col. 18 ll. 28–30. “Communications between the interface controller and the rest of the system 250 through the transmitter 286 and the optional receiver 302 comprise ‘in-band’ communication.” *Id.* at col. 19 ll. 22–24. “[O]ut-of-band communication signals 304 between the controller 280 and, for example, a local server 266A” are also demonstrated. *Id.* at col. 19 ll. 25–27. “These ‘out-of-band’ signals can include, for example, high speed data communication to provide real time video (e.g. streaming video over the Internet) on the display 298.” *Id.* at col. 19 ll. 27–30.

The claim term “relationship” does not appear in the specification.

## B. Procedural History

On January 10, 2014, the district court held a *Markman* hearing on the parties' proposed claim constructions for asserted claims 1 and 5 of the '351 patent, including the terms "in-band communication," "out-of-band communication," "out-of-band device," and the claimed "relationship" between the out-of-band communication and the in-band communication. *Nautilus, Inc. v. Biosig Instruments, Inc.*, 134 S. Ct. 2120 (2014), issued later that year, and, as a result, the district court heard re-argument and allowed supplemental briefing, allowing the parties to address the change in the law. *Icon Health & Fitness, Inc.*, 2015 WL 2376056 at \*1.

The court asked the parties to retain experts in order to ascertain the perspective of persons skilled in the art to construe the terms. *Id.*; *see also* Joint Appendix ("J.A.") 750 ("Having considered the parties' briefs and the arguments of counsel, the court finds it is unable to construe purported claims without the assistance of those skilled in the art."). The parties filed supplemental claim construction briefs and the district court held an evidentiary hearing to hear expert testimony as well as oral argument. *Id.* The focus of this post-*Nautilus* round of argument was on the terms "in-band communication," "out-of-band communication," "out-of-band device," and the claimed "relationship" between the out-of-band communication and the in-band communication.

On May 18, 2015, after consideration of expert testimony, the district court dismissed with prejudice Icon's claim against Polar for infringement. The court found that the '351 patent claim terms—"in-band," "out-of-band," and "relationship"—are ambiguous and incapable of construction; therefore, the court held that the '351 is invalid for indefiniteness. We have jurisdiction pursuant to 28 U.S.C. § 1295(a)(1).



## DISCUSSION

The definiteness requirement is found in the second paragraph of 35 U.S.C. § 112, which reads: “The specification shall conclude with one or more claims particularly pointing out and distinctly claiming the subject matter which the applicant regards as his invention.” In *Nautilus*, the Supreme Court stated the test for whether a claim meets the requirements of § 112, ¶ 2 as follows: “[W]e read § 112, ¶ 2 to require that a patent’s claims, viewed in light of the specification and prosecution history, inform those skilled in the art about the scope of the invention with reasonable certainty.” *Nautilus*, 134 S.Ct. at 2129.

While we review the district court’s legal conclusion regarding indefiniteness *de novo*, we must review any underlying factual determination for clear error. *Teva Pharm. USA, Inc. v. Sandoz, Inc.*, 135 S. Ct. 831, 842 (2015). And, “[a]ny fact critical to a holding on indefiniteness . . . must be proven by the challenger by clear and convincing evidence.” *Intel Corp. v. VIA Techs.*, 319 F.3d 1357, 1366 (Fed. Cir. 2003). Claim construction is also a question of law, but similarly may have factual underpinnings. “Though the ultimate construction of a claim term is a legal question reviewed *de novo*, underlying factual determinations made by the district court based on extrinsic evidence are reviewed for clear error.” *Biosig Instr.*, 783 F.3d at 1378 (citing *Teva*, 135 S. Ct. at 842). “[W]hen the district court reviews only evidence intrinsic to the patent (the patent claims and specifications, along with the patent’s prosecution history), the judge’s determination will amount solely to a determination of law, and the Court of Appeals will review that construction *de novo*.” *Teva*, 135 S. Ct. at 841.

At the district court and in front of this court, Icon’s and its expert’s position has been that “in-band” and “out-of-band” communications are different from each other,

and that the fact that there is a difference is alone sufficient to render the claims definite and capable of construction. *See, e.g.*, Appellant Br. 57 (“‘in-band’ refers to one pathway, and ‘out-of-band’ refers to a different pathway.”) Icon’s expert opined:

It is . . . my expert opinion that one of ordinary skill in the art would reasonably understand the claim terms [“in-band” and “out-of-band”] as follows. First, “in-band communication” would be reasonably understood by those of skill in the art as communication to or from the exercise apparatus. Second, “out-of-band communication” would be reasonably understood by those of skill in the art as any communication other than the in-band communication. . . . Finally, “out-of-band communication device” would be reasonably understood by those of skill in the art as a device capable of any communication other than the in-band communication.

J.A. 950.

Polar’s expert does not disagree that the terms are indeed distinct. *See* Appellant Br. 23–24 (listing instances where Polar’s expert notes, in agreement with Icon’s expert, that “in-band” and “out-of-band” are separate and distinct from one another). Instead, Polar’s expert argues that “the ’351 patent does not provide one skilled in the art with sufficient information to define these terms with reasonable certainty” and the “terms as used in the ’351 patent are ambiguous” without some sort of reference to provide context. J.A. 795, ¶ 2. The “relationship” between “in-band” and “out-of-band,” according to Polar’s expert, is completely unspecified. Indeed, there is no reference provided in the specification to teach a person of ordinary skill what constitutes an in-band communication versus an out-of-band communication (other than the fact

that they are different) or how the two are related. As Polar's expert explained:

Regardless of the medium used to transfer information (e.g., radio-frequency signals, or infrared signals, or acoustic signals, or tactile signals), the needed reference for what would comprise "in-band communication" versus "out-of-band communication" is missing from the claim. . . . "[I]n-band" and "out-of-band" are relative terms. The reference could be a particular "band" (or equivalent), or information flow (also called a "traffic flow"), which can serve to anchor the meaning of the terms. Clearly, *any* communication can be considered to be "in-band" to itself (i.e., the communication signal fills or occupies whatever "band" or equivalent resource that it needs). Thus, reading the plain words of the claim, one of ordinary skill would be unable to assign any meaning at all to the adjective "in-band", or determine how an "in-band communication" might differ from "communication" in the more general sense. One of ordinary skill in the art would understand that the words of the claims are supposed to have meaning, and "in-band communication" should be narrower (more limiting) than "communication". But, unless the meaning can be elucidated from the specification or file history, there would be no way to draw this distinction, and thereby determine the metes and bounds of the claim (and the claims that depend from this claim) with reasonable certainty.

J.A. 886, ¶ 60.

The ambiguity, Polar's expert continued, is exacerbated by the fact that the "out-of-band communication" is completely untethered to the "in-band communication," such that the "out-of-band communication" could even be

a conversation had completely outside the claimed system:

The [“out-of-band communication”] device is required to be “capable of a communication with a user”. This wording describes a communication between an apparatus and a human, and adds an additional layer of ambiguity since it is not clear if the recited structure is an “out-of-band communication device” because: a) it communicates with another element of structure (which is unspecified) by a method of communication which is considered “out-of-band” relative to an unspecified reference; or b) it communicates with a human. . . . The “out-of-band communication device” could be the user’s cell phone, or a wired telephone, and there is not even an implied requirement for it to exchange information with any other part of the claimed system—as long as the out-of-band communication has an unspecified “relationship” to the in-band communication.

J.A. 890–91, ¶ 69 (footnotes omitted).

To support its position that a reference is required to provide context and give terms “in-band” and “out-of-band” meaning, Polar’s expert proffered ten extrinsic prior art patents and text books, each of which “defines a reference that allows the reader to differentiate in-band from out-of-band in relation to that reference.” *Icon Health & Fitness, Inc.*, 2015 WL 2376056 at \*10.

It was on the basis of these ten extrinsic references that the district court concluded “that those skilled in the art understand that the terms ‘in-band’ and ‘out-of-band’ are relative terms, and only have meaning in a given context with a defined reference, such as a frequency, a channel, a protocol, time slots, and data streams.” *Id.* This is precisely the type of extrinsic evidence upon which a district court may rely in analyzing the record before it

when construing claim terms. The district court’s findings on such evidence constitute findings of fact, and we review such factual findings for clear error. *Teva*, 135 S. Ct. at 841. Here, we find no clear error in the district court’s findings of fact, based on the extrinsic evidence presented by Polar’s expert, nor do we find error in the legal conclusion it draws from this factual premise.<sup>1</sup>

For the first time on appeal, Icon raises new arguments to distinguish “in-band” from “out-of-band” based on the use of those terms throughout the specification. It argues that “it is evident that references to ‘out-of-band’ are intended to describe an enhancement over ‘in-band,’ in that enhanced technology, something different in kind—something more complex, or more powerful, or more expensive—is required to facilitate ‘out-of-band’ communications, interactions and experiences.” Appellant Br. 32; *see id.* at 31–44 (citing the specification of the ’351 patent for support). In this way, “in-band” functionality is “simple and inexpensive,” “[b]ut if consumers wanted something more,” they could get the “optional enhancement” that is the “out-of-band” communications. *Id.* at 36.

Polar argues that this line of argument is waived. At the district court, Icon’s claim construction contained “no

---

<sup>1</sup> We find, moreover, no merit in Icon’s argument that the district court either (1) should not have looked to extrinsic evidence because the intrinsic evidence was sufficient, or (2) that the expert’s testimony was purely legal in nature. *See* Appellant Br. 47, 50–51. The former fails because, as demonstrated above, the indefiniteness of the claim terms simply cannot be resolved by reference solely to the intrinsic evidence (i.e., the claims, specification, and prosecution history). The latter fails because Polar’s expert’s un rebutted analysis was based on a review of ten extrinsic references.

inexpensiveness limitations, no complexity limitations, no powerfulness limitations, and no standard-issue limitations.” Appellee Br. 28. As such, Polar argues, this distinction for purposes of claim construction and definiteness, made for the first time on appeal, is waived. *See Sage Products, Inc. v. Devon Indus., Inc.*, 126 F.3d 1420, 1426 (Fed. Cir. 1997) (“With a few notable exceptions, such as some jurisdictional matters, appellate courts do not consider a party’s new theories, lodged first on appeal.”). Icon disagrees. It argues that it is not presenting a new scope of claim construction. Rather, it is “proffering additional or new supporting arguments, based on evidence of record, for its claim construction.” *Interactive Gift Exp., Inc. v. Compuserve Inc.*, 256 F.3d 1323, 1347 (Fed. Cir. 2001).

Because any new argument drawn from the specification is intended only to reinforce Icon’s assertion that “‘in-band’ and ‘out-of-band’ are separate and distinct instances of communication, related to one another under the plain and ordinary meaning of the ‘relationship’ between the two described in the specification (i.e., that they both relate to a common, single exercise session),” such arguments are redundant and unnecessary. Appellant Reply Br. 15. Polar does not contest, and the district court did not question, that “in-band” and “out-of-band” are “separate and distinct.” Rather, Polar argues that the ambiguous nature of the distinction between the two claim terms renders them incapable of construction. We agree.

In *Amgen Inc. v. Hoechst Marion Roussel, Inc.*, 314 F.3d 1313 (Fed. Cir. 2003), one of the claims-at-issue disclosed an erythropoietin glycoprotein product “having glycosylation which differs from that of human urinary erythropoietin,” or uEPO. *Id.* at 1340. The district court found that “two uEPO preparations produced from the same batch of starting materials could nevertheless have different glycosylation patterns.” *Id.* at 1341. Thus, the claim itself was a moving target; as we explained, “one

must know what the glycosylation of uEPO is with certainty before one can determine whether the claimed glycoprotein has a glycosylation *different from* that of uEPO.” *Id.* (emphasis added). This court therefore affirmed the district court’s finding that the claims requiring “glycosylation which differs” were invalid for indefiniteness. *Id.* at 1342. Here, Icon argues that the scope of the claim term “in-band” would be selected by a person of ordinary skill, but that the scope could vary from day-to-day and from person-to-person. It argues that “[t]he inventors were prescient . . . and recognized that what is prohibitively expensive or complex today may be rudimentary tomorrow.” Appellant Br. 40–41. “In-band” cannot provide a basis, therefore, to determine which communications are “out-of-band” if the terms are a moving target that may change over time.

#### CONCLUSION

The district court did not err by relying on expert testimony to conclude that “in-band” and “out-of-band” are relative terms that have meaning only in the context of a defined reference. Because the ’351 patent’s claims, “read in light of the specification delineating the patent, and the prosecution history, fail to inform, with reasonable certainty, those skilled in the art about the scope of the invention,” *Nautilus*, 134 S.Ct. at 2124, and because we do not find any of Icon’s other arguments persuasive, we affirm the district court’s finding that the ’351 patent is invalid for indefiniteness.

The ruling of the district court that Icon’s assertion of the ’351 patent is barred by the doctrine of issue preclusion in *Icon Health & Fitness, Inc. v. Garmin Int’l*, No. 1:11-CV-166-RJS, 2015 WL 5714248 (D. Utah Sept. 29, 2015), is also affirmed.

**AFFIRMED**