

NOTE: This disposition is nonprecedential.

**United States Court of Appeals
for the Federal Circuit**

PROFOOT, INC.,
Plaintiff-Appellant

v.

MERCK & CO., INC.,
Defendant-Appellee

2016-1216

Appeal from the United States District Court for the Northern District of Illinois in No. 1:11-cv-09004, Judge John Z. Lee.

Decided: October 26, 2016

WILLIAM L. NIRO, Niro Law Group, LLC, Chicago, IL, argued for plaintiff-appellant. Also represented by CHRISTOPHER W. NIRO.

DANIEL A. BOEHNEN, McDonnell, Boehnen, Hulbert & Berghoff, LLP, Chicago, IL, argued for defendant-appellee. Also represented by ANTHOULA POMRENING, JORDAN JOSEPH PRINGLE.

Before PROST, *Chief Judge*, TARANTO and HUGHES, *Circuit Judges*.

PROST, *Chief Judge*.

ProFoot, Inc. (“ProFoot”) appeals from a stipulated judgment of noninfringement entered by the United States District Court for the Northern District of Illinois in favor of Merck & Co., Inc. (“Merck”), following claim construction of U.S. Patent No. 6,845,568 (“568 patent”). For the reasons stated below, we affirm.

BACKGROUND

ProFoot is the owner of the ’568 patent, entitled “High Performance Foot Bed for Sports Equipment.” The invention is a method for providing custom footwear inserts for sports that involve symmetrical, side-to-side movement, such as skiing, skating, and cycling. ’568 patent col. 1 ll. 9–12. The inserts “position[] the ankle joint or sub taylor [sic] joint in a relaxed position by correcting the pronation^[1] of the foot.” *Id.* at col. 1 ll. 13–15. This reduces non-functional tension in the subtalar joint, which “increases the amount of relatedness between the foot and ankle joint” and allows the athlete to move side-to-side (e.g., shifting weight when making turns down a ski hill) with greater agility. *Id.* at col. 1 ll. 45–50, col. 2 ll. 23–28. The ’568 patent touts that its solution is superior to prior art solutions, because it determines this “relaxed position” while an athlete is standing on one foot, instead of on two. *Id.* at col. 2 ll. 5–7.

To determine the insert that is best for a particular athlete, the patent teaches the use of a special device called a “neutralizer.” *Id.* at abstract, col. 3 ll. 1–15. The

¹ Pronation refers to the natural inward rolling of the foot that happens as a person walks or runs. ’568 patent col. 1 ll. 19–20.

athlete steps on the “neutralizer” one foot at a time, and a fitting specialist uses the “neutralizer” to determine what angle the foot should be in to place the ankle in a “neutral position.” *Id.* at col. 5 ll. 11–15. The specification explains that “[t]o achieve a neutral position, the operator visually examines the tendons by the ankle until they are in a relaxed state or are working equally.” *Id.* at col. 4 ll. 22–24. It also discloses two different embodiments of the “neutralizer,” shown in Figures 1 and 2:

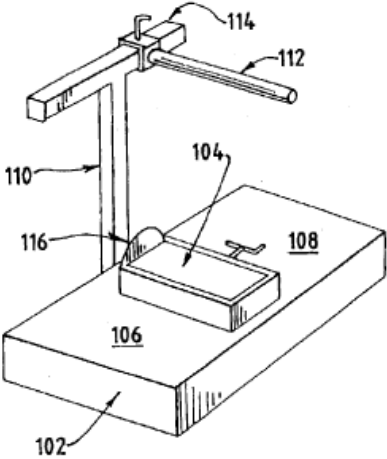
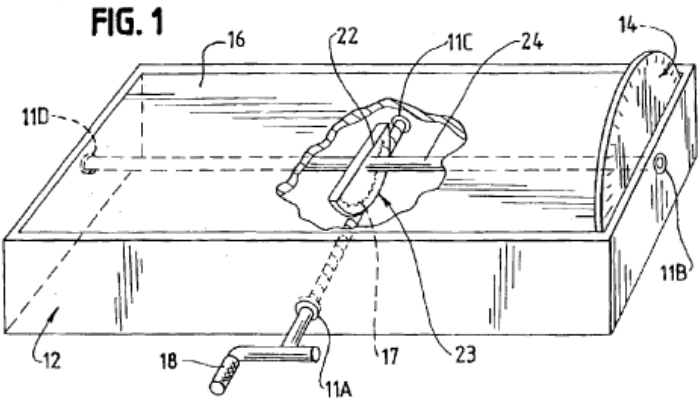

FIG. 2

Claims 1 and 3 are asserted. They recite:

1. A method of fitting an individual with right and left foot inserts which place the ankles of the individual in a neutral position comprising the steps of:

for creating a right foot insert, having the individual place the right foot on a *neutralizer* while elevating the left foot off of the *neutralizer*;

using the *neutralizer* to determine the angle necessary to place the right ankle in a *neutral position*;

providing an insert having an angle which represents the *neutral state* for the right ankle;

for creating a left foot insert, having the individual place the left foot on a *neutralizer* while elevating the right foot off of the *neutralizer*;

using the *neutralizer* to determine the angle necessary to place the left ankle in a *neutral position*;

and

providing an insert having an angle which represents the *neutral state* for the left ankle.

....

3. The method of claim 1 wherein said insert is provided to a user by selecting said insert from a plurality of predetermined inserts.

'568 patent col. 5 l. 14–col. 6 l. 14 (emphases added).

On June 17, 2015, the district court construed the terms “neutralizer” and “neutral position,” as well as four others. The district court construed “neutralizer” as “a device that has a housing, a protractor, and an angularly adjustable plate capable of supporting the foot.” J.A. 10. It construed “neutral position” as “a position in which

subtalar joint is in the relaxed position due to the lack of pronation or supination.” J.A. 12.

Based on the district court’s constructions, the parties stipulated to a judgment of noninfringement of all of the asserted claims of the ’568 patent. The district court entered final judgments under Rule 54(b) of the Federal Rules of Civil Procedure.

ProFoot now appeals. We have jurisdiction pursuant to 28 U.S.C. § 1295(a)(1).

DISCUSSION

A claim term’s ultimate construction is a question of law reviewed de novo, while underlying factual determinations are reviewed for clear error. *Teva Pharm. USA, Inc. v. Sandoz, Inc.*, 135 S.Ct. 831, 842 (2015). “When the district court reviews only evidence intrinsic to the patent (the patent claims and specifications, along with the patent’s prosecution history), the judge’s determination will amount solely to a determination of law, and the Court of Appeals will review that construction de novo.” *Id.* at 841.

ProFoot challenges the district court’s construction of two claim terms: (1) “neutralizer,” and (2) “neutral position.” The parties agree that, under the district court’s construction of “neutralizer” alone, Merck does not infringe the ’568 patent. Oral Argument at 1:30–2:01, 23:55–24:26, *available at* <http://oralarguments.cafc.uscourts.gov/default.aspx?fl=2016-1216.mp3>. Because we agree that the district court correctly construed this term, we do not reach “neutral position.”

With respect to “neutralizer,” ProFoot argues that the district court erred by naming specific components that comprise the neutralizer (e.g., a housing, a protractor, and an angularly adjustable plate capable of supporting the foot) in its construction. In ProFoot’s view, this construction is too narrow because the claims are silent as to what

components comprise the neutralizer, and a person of ordinary skill in the art would recognize that a “neutralizer” is simply just some kind of measuring device. ProFoot posits that the district court relied too heavily on the ’568 patent’s specification and also the prosecution history from the parent to the ’568 patent, U.S. Patent No. 6,564,465 (“the parent ’465 patent”), neither of which it contends are controlling. We address each in turn.

The words of a claim are generally given their ordinary and customary meaning, which is the meaning that the term would have to a person of ordinary skill in the art at the time of the invention. *Phillips v. AWH Corp.*, 415 F.3d 1303, 1312–13 (Fed. Cir. 2005) (en banc). Claim terms “do not stand alone,” but “must be read in view of the specification, of which they are a part.” *Id.* at 1315 (citation omitted). The specification is “highly relevant” and often “the single best guide to the meaning of a disputed term.” *Id.* (citation omitted). In addition, “the prosecution history can often inform the meaning of the claim language by demonstrating how the inventor understood the invention.” *Id.* at 1317. Accordingly, “the only meaning that matters in claim construction is the meaning in the context of the patent.” *Trs. of Columbia Univ. v. Symantec Corp.*, 811 F.3d 1359, 1363 (Fed. Cir. 2016).

Although ProFoot is correct that the asserted claims do not recite the specific components that comprise the neutralizer, we agree with the district court that, when read in the context of the ’568 patent, this term requires a device that includes these components. We begin with the claims themselves, as “the context in which a term is used in the asserted claim can be highly instructive.” *Phillips* 415 F.3d at 1314. Here, the claims state that the neutralizer is something that the athlete steps on, one foot at a time, *see id.* at col. 5 ll. 11–13, col. 6 ll. 3–5, and is “us[ed] . . . to determine the angle necessary to place the [left/right] ankle in a neutral position,” *id.* at col. 5 ll. 14–

15, col. 6 ll. 6–7. It would be hard to imagine how this could be accomplished without something for the athlete to step on—such as an angularly adjustable plate capable of supporting the foot—and something to measure an angle—such as a protractor. Although this language, by itself, is not strong enough to require these components, it at least supports the district court’s construction.

The specification, however, closes this gap. “[W]hen a patent ‘repeatedly and consistently’ characterizes a claim term in a particular way, it is proper to construe the claim term in accordance with that characterization.” *GPNE Corp. v. Apple Inc.*, 830 F.3d 1365, 1370 (Fed. Cir. 2016) (citing *VirnetX, Inc. v. Cisco Sys., Inc.*, 767 F.3d 1308, 1318 (Fed. Cir. 2014); *ICU Med., Inc. v. Alaris Med. Sys., Inc.*, 558 F.3d 1368, 1374–75 (Fed. Cir. 2009)). Here, the specification discloses only two embodiments of the neutralizer. ’568 patent col. 3 ll. 1–15. Both name all the components listed in the district court’s construction:

The present invention includes a number of components such as a foot neutralizer 10 as shown in FIG. 1 Neutralizer 10 includes a *housing* 12, *protractor* 14, an *angularly adjustable plate* 16, crank 18 with threaded rod 19 having threads 23 that coact with threads 21 on support 22, and rod 24. Bearings 11A, 11B, 11C and 11D may also be provided for ease of operation.

FIG. 2 shows an alternate embodiment of a foot neutralizer 100. It includes a *housing* 102, *angularly adjustable plate* 104, foot rests 106 and 108, upright support bar 110, and a positionable horizontal bar 112 that adjustably slides along bar 114 of support 110. Also included is *protractor* 116.

Id. (emphases added). In addition, the abstract states that “[t]he neutralizer has a *housing, protractor, and an angularly adjustable plate capable of supporting the foot.*”

Id. at abstract (emphasis added). At no point does the patent describe an embodiment of a neutralizer that does not have these components, nor does it give any indication that it contemplates a neutralizer that would not have these components. Rather, inclusion of these components is consistent with the specification's description of how the neutralizer is used: the athlete stands on the device (e.g., through the angularly adjustable plate, encased in or sitting on top of a housing) and the fitting specialist uses it to determine the angle that would place the foot in a "neutral position" (e.g., using a protractor). *See id.* at col. 4 ll. 7–9, 40–42, 50–59; *see also* col. 5 ll. 11–15, col. 6 ll. 3–7. Accordingly, because the specification consistently and repeatedly discloses that the neutralizer includes the housing, protractor, and angularly adjustable plate components, the district court did not err in including them in its construction.

Finally, the prosecution history of the parent '465 patent supports the district court's construction. Originally, when the application for the parent '465 patent was filed, it contained a single claim for "[a] method for creating a pair of foot inserts" that recited a process similar to that claimed in claim 1 of the '568 patent, but did not recite any specific device or mechanism that was used to perform this process. J.A. 100. However, through a series of amendments seeking to overcome prior art rejections, this claim was eventually cancelled and replaced with a claim that recited a substantially similar process but also specifically required "a neutralizer . . . said neutralizer having a housing, protractor, an angularly adjustable plate capable of supporting a foot" to perform the claimed process. J.A. 147. Although this history arose during prosecution of the parent '465 patent, it is still relevant here as evidence of the inventor's understanding of "neu-

tralizer” at the time.² See *Phillips* 415 F.3d at 1317 (“[T]he prosecution history can often inform the meaning of the claim language by demonstrating how the inventor understood the invention.”); cf. *Ormco Corp. v. Align Tech., Inc.*, 498 F.3d 1307, 1314 (Fed. Cir. 2007) (“When the application of prosecution disclaimer involves statements from prosecution of a familial patent relating to the same subject matter as the claim language at issue in the patent being construed, those statements in the familial application are relevant in construing the claims at issue.”). The specifications and the claims of the parent ’465 patent and the ’568 patent are substantially similar, and nowhere in the ’568 patent does the inventor indicate that he intended the “neutralizer” of the ’568 patent to be different from the “neutralizer” in the parent ’465 patent. Accordingly, the prosecution history of the parent ’465 patent also supports the district court’s inclusion of the

² In addition, we have recognized that prosecution history disclaimer in a parent application may bind continuation or continuation-in-part applications, if they involve the same claim limitation. *Omega Eng’g, Inc. v. Raytek Corp.*, 334 F.3d 1314, 1333 (Fed. Cir. 2003) (“As long as the same claim limitation is at issue, prosecution disclaimer made on the same limitation in an ancestor application will attach.”). This is not the case here because, even though both claim 1 of the parent ’465 patent and claim 1 of the ’568 patent include the term “neutralizer,” only claim 1 of the parent ’465 patent contains the limitation “said neutralizer having a housing, protractor, an angularly adjustable plate capable of supporting a foot.” To the extent there is prosecution history disclaimer in the parent ’465 patent (a question we decline to answer), only this limitation would disclaim all neutralizers that do not contain these three components, so this disclaimer cannot be inherited by the ’568 patent.

housing, protractor, and angularly adjustable plate components within the meaning of “neutralizer.”

ProFoot nevertheless contends that the prosecution history does suggest that the “neutralizer” of the ’568 patent was intended to be different from the “neutralizer” in the parent ’465 patent because claim 1 of the parent ’465 patent recites “said neutralizer having a housing, protractor, an angularly adjustable plate capable of supporting a foot” but claim 1 of the ’568 patent does not. This argument turns the correct analysis on its head. Here, the prosecution history merely stands as supporting evidence that, starting with the parent ’465 patent, the inventor understood “neutralizer” to include the housing, protractor, and angularly adjustable plate components. The omission of these limitations in the ’568 patent is not inconsistent with this; instead, the overwhelming similarities between the parent ’465 patent and the ’568 patent suggest that the inventor intended “neutralizer” to have the same meaning between the two patents. If he had not, he could have said so explicitly, or revised the ’568 patent to include other, broader embodiments of the neutralizer. Accordingly, when read in combination with the rest of the intrinsic evidence, the prosecution history supports, rather than refutes, the district court’s construction.

We also do not find any of the other arguments that ProFoot advances in support of its position persuasive. For example, ProFoot argues that a person of ordinary skill in the art would recognize that a “neutralizer” is simply just some kind of measuring device, pointing to an asserted prior art reference, U.S. Patent No. 5,979,067 to Waters (“Waters”), for support. However, Waters does not contain the word “neutralizer,” *see* J.A. 593–602, which appears to be a term coined by the inventor of the ’568 patent. Moreover, this is extrinsic evidence, which is “less significant than the intrinsic record in determining the ‘legally operative meaning of claim language.’” *Phillips*,

415 F.3d at 1317 (citations omitted). Accordingly, in light of the compelling intrinsic record supporting the district court's construction, this does not compel a different result.

CONCLUSION

The district court did not err in construing the term "neutralizer." We need not reach "neutral position" because, under the district court's construction of "neutralizer," Merck does not infringe. Oral Argument at 1:30–2:01, 23:55–24:26. We therefore affirm the district court's stipulated judgment of noninfringement.

AFFIRMED