

NOTE: This disposition is nonprecedential.

**United States Court of Appeals  
for the Federal Circuit**

---

**LG ELECTRONICS, INC.,**  
*Appellant*

v.

**CONVERSANT WIRELESS LICENSING S.A.R.L.,**  
*Appellee*

---

2017-2028, 2017-2029

---

Appeals from the United States Patent and Trade-  
mark Office, Patent Trial and Appeal Board in Nos.  
IPR2015-1984, IPR2015-1985.

-----  
**CONVERSANT WIRELESS LICENSING S.A.R.L.,**  
*Appellant*

v.

**APPLE INC.,**  
*Appellee*

---

2018-1185, 2018-1186

---

Appeals from the United States Patent and Trademark Office, Patent Trial and Appeal Board in Nos. IPR2015-01898, IPR2015-01899.

---

Decided: January 25, 2019

---

RYAN C. MORRIS, Sidley Austin LLP, Washington, DC, argued for appellant in 17-2028. Also represented by CARTER GLASGOW PHILLIPS, DANIEL HAY; PETER H. KANG, Palo Alto, CA; JAMES SUH, LG Electronics Inc., Seoul, Korea.

KAYVAN B. NOROOZI, Noroozi PC, Santa Monica, CA argued for appellant in 18-1185. Also represented by MARC AARON FENSTER, REZA MIRZAIE, Russ August & Kabat, Los Angeles, CA; WAYNE MICHAEL HELGE, Davidson Berquist Jackson & Gowdey, LLP, McLean, VA.

BENJAMIN T. WANG, Russ August & Kabat, Los Angeles, CA, argued for appellee in 17-2028. Also represented by MARC AARON FENSTER, ADAM S. HOFFMAN, REZA MIRZAIE; WAYNE MICHAEL HELGE, Davidson Berquist Jackson & Gowdey, LLP, McLean, VA; KAYVAN B. NOROOZI, Noroozi PC, Santa Monica, CA.

DOUGLAS HALLWARD-DRIEMEIER, Ropes & Gray LLP, Washington, DC, argued for appellee in 18-1185. Also represented by SCOTT ANTHONY MCKEOWN; CHRISTOPHER M. BONNY, East Palo Alto, CA.

---

Before LOURIE, O'MALLEY, and TARANTO, *Circuit Judges*.  
O'MALLEY, *Circuit Judge*.

Apple Inc. and LG Electronics, Inc. separately petitioned for *inter partes* review of U.S. Patent Nos.

8,434,020 and 8,713,476, assigned to Conversant Wireless Licensing S.A.R.L. The Patent Trial and Appeal Board (“Board”) instituted review of both petitions and issued final written decisions upholding the LG-challenged claims as not obvious over U.S. Patent No. 6,415,164 (“Blanchard”) and finding the Apple-challenged claims unpatentable as obvious over U.S. Patent No. 7,225,409 (“Schnarel”), in combination with U.S. Patent No. 6,993,362 (“Aberg”), and U.S. Patent No. 6,593,945 (“Nason”). Final Written Decision (Paper 41), *LG Elecs., Inc. v. Core Wireless Licensing S.A.R.L.*, IPR2015-1984 & -1985 (P.T.A.B. Mar. 15, 2017); Final Written Decision (Paper No. 42), *Apple, Inc. v. Core Wireless S.A.R.L.*, IPR2015-1898 & -1899 (P.T.A.B. Mar. 15, 2017). LG and Conversant appeal the Board’s decisions, respectively.

Because we agree with the Board’s decision invalidating the Apple-challenged claims in light of Schnarel and Aberg and its decision upholding the LG-challenged claims over Blanchard, we *affirm*.

## I. BACKGROUND

### A. The ’020 and ’476 Patents

The ’020 and ’476 patents, both titled “Computing Device with Improved User Interface for Applications,” share a nearly identical specification and are directed toward solving problems with small display screens on computing devices. Due to the more limited space on smaller display screens, data and functionality are typically divided into many layers or views, prohibiting users from being able to “navigate quickly and efficiently to access data and activate a desired function.” ’020 patent, col. 1 ll. 27–29.

The patents tackle these small screen limitations by creating an “application summary” or “application summary window” that can be reached directly from the main menu on the display. The “application summary window” allows the user to view a limited list of common functions

and commonly accessed stored data on the main menu. *Id.* at col. 2 ll. 28–30, 55–59. By selecting data or a desired function from the summary window, the user can directly launch the related function or application without having to navigate through multiple levels of functionality.

In Fig. 1 of the '020 patent, for example, the user is presented with a default display of various applications. Once the user selects an application from the list, Fig. 2 shows that an “application summary window” drops down from the selected application, quickly informing the user of certain data (e.g., number of new messages) and linking to common functions (e.g., create message).

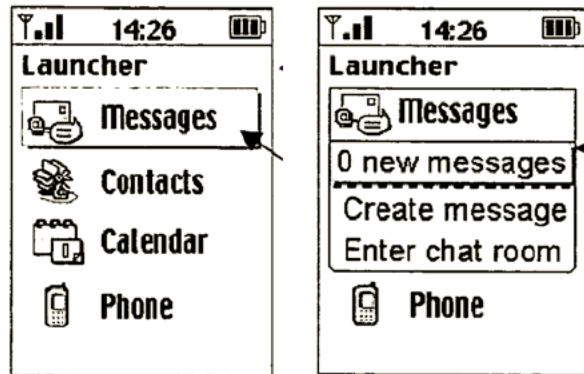

Figure 1

Figure 2

Independent claim 1 of the '020 patent is representative and provides:

1. A computing device comprising a display screen, the computing device being configured to display on the screen a menu listing at least a first application, and additionally being configured to display on the screen an application summary window that can be reached directly from the main menu, wherein the application

summary window displays a limited list of at least one function offered within the first application, each function in the list being selectable to launch the first application and initiate the selected function, and wherein the application summary window is displayed while the application is in an unlaunched state.

*Id.* at col. 5 ll. 33–43. Claim 1 of the '476 patent is nearly identical to claim 1 of the '020 patent, but, rather than reciting an “application summary window” and a limited list of “functions,” claim 1 of the '476 patent discloses an “application summary” and a limited list of “data.” '476 patent, col. 5 l. 59–col. 6 l. 3.

#### B. The Prior Art

Three prior art references are at issue in this appeal: (1) Blanchard, (2) Schnarel, and (3) Aberg.<sup>1</sup> All three references are patents aimed at optimizing screen space on small displays. Blanchard, titled “Arrangement for Dynamic Allocation of Space on a Small Display of a Telephone Terminal,” discloses an interactive telephone interface that uses a series of menus and sub-menus within a “parent menu.” Blanchard, col. 3 ll. 21–25, 54–58, col. 4 ll. 12–14. As shown in Fig. 3 below, the parent menu contains five applications—Home, Phone Book, Mailbox, Security, and Tools—that are each allocated their own screen. *See id.* at col. 3 ll. 3–9, 54–58.

---

<sup>1</sup> The Board additionally found the Apple-challenged claims unpatentable as obvious over Nason. Because we affirm the Board’s decisions based on Schnarel in combination with Aberg, we do not reach the parties’ arguments regarding Nason.

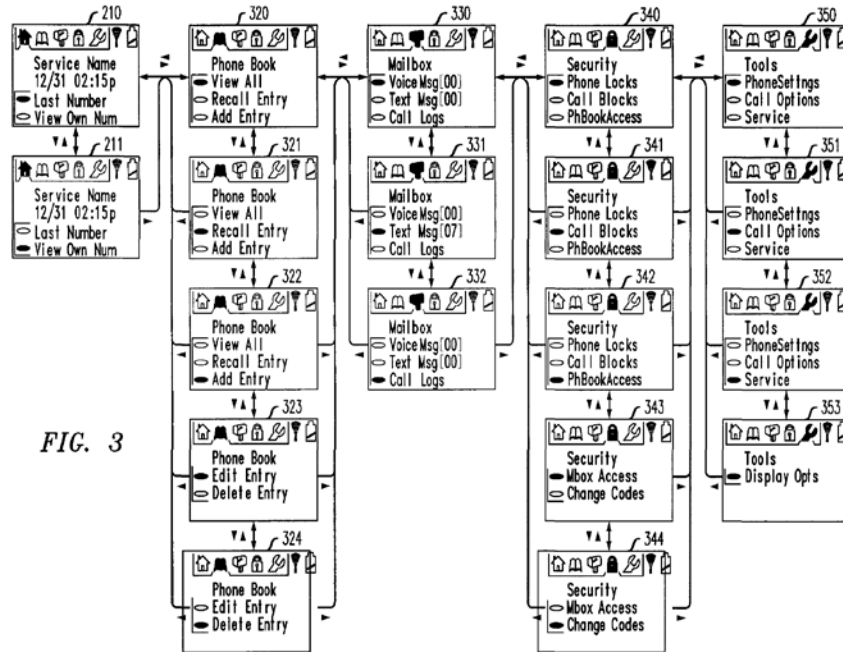
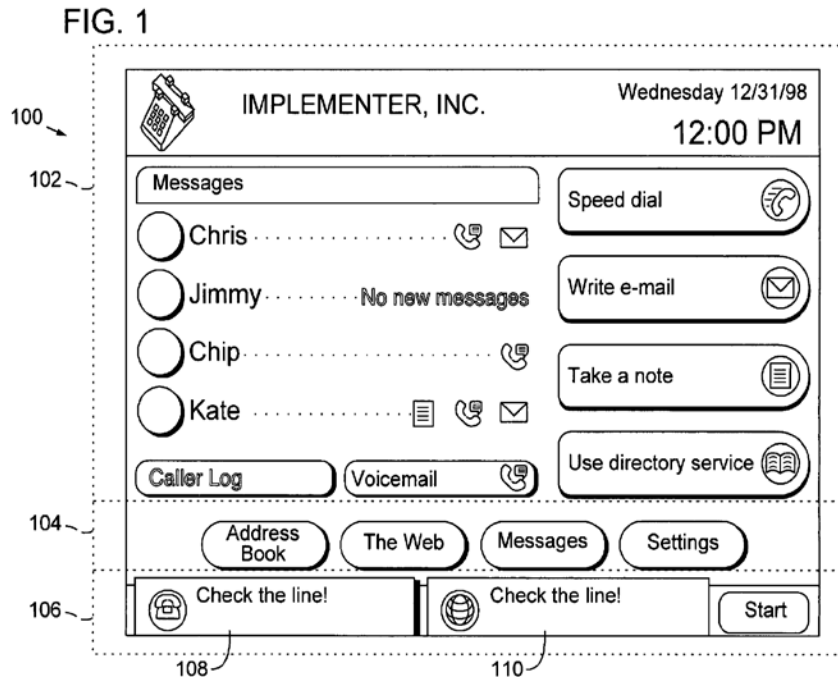

FIG. 3

When a user scrolls to a certain application screen, she is presented with different selectable menu items, such as the ability to “view entries” in the Phone Book application or change “phone settings” in the Tools application. Blanchard, col. 4 ll. 17–30, Fig. 3. Each menu within an application, moreover, can be “dynamically varied for presentation of various types of user information.” *Id.* at col. 6 ll. 32–33.

Schnarel, titled “Graphical User Interface for a Screen Telephone,” describes a graphical user interface implemented as a “start” or “home” screen on a web telephone or other telephony device. Schnarel, col. 4 ll. 18–22. The “home” screen is broken into multiple display areas, including a pane area, an application selection area (or application button bar), and a call slip area, shown in Fig. 1, below. *Id.* at col. 4 ll. 34–37.



The pane area (102) comprises different windows “designed to allow customization of the start screen,” including a “message pane” that notifies users of and allows quick access to new messages, and a “task pane” that allows quick access to device features, such as “speed dial” and “write e-mail.” *Id.* at col. 5 ll. 8–9, 12–13, 51–52, col. 6 ll. 27–34. The application program selection area (104) contains multiple control buttons “that enable a user to select an application program, such as a web browser, address book, or answering machine/e-mail message retrieval application.” *Id.* at col 2 ll. 23–26. Finally, the call slip area (106) displays elements associated with the telephone line. *Id.* at col. 4 ll. 56–59.

Aberg, titled “Portable Communication Apparatus Having a Hierarchical Menu System and a Dynamic Menu,” describes a dynamic hierarchical menu system for portable communication devices. Aberg, col. 1 ll. 7–13. Aberg’s hierarchical menu system includes three levels of menus: top-level menus, sub-level menus, and selectable menu items, shown below in Fig. 3. *Id.*

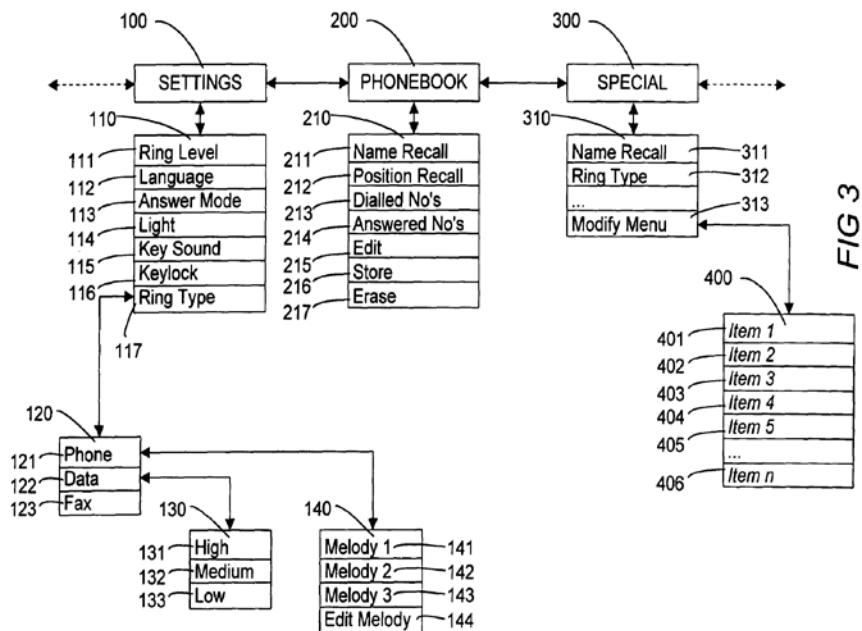

Aberg teaches that the “essence” of its invention “lies in the provision of the SPECIAL top-level menu 300, which is dynamic (the contents may be modified by the user) and is accessible through the normal menu system.” *Id.* at col. 5 ll. 62–65, col. 4 ll. 34–35. While the “special” menu is initially described as a “top-level menu,” Aberg teaches that it “may be located anywhere further down the menu hierarchy.” *Id.* at col. 7 ll. 26–29. When the user selects a menu item from the “special” menu, the “corresponding function will be invoked, in precisely the same manner as if the particular menu item were selected via any of the regular menus 100, 200, etc., elsewhere in the menu system.” *Id.* at col. 6 ll. 19–24.

### C. Procedural History

Apple petitioned for *inter partes* review on September 12, 2015 after being sued by Conversant in the Eastern District of Texas. Apple asserted that claims 1, 2, 6, 8, 10, 11, 13, and 16 of the '020 patent and claims 1, 4, 7–9, 20, 28, and 29 of the '476 patent were unpatentable over multiple prior art references, including, as relevant to this



appeal, Schnarel, alone or in combination with Aberg, and Nason (the “Apple IPRs”). The Board instituted on both grounds, ultimately concluding in its Final Written Decisions that the challenged claims were unpatentable as obvious over Schnarel in combination with Aberg (but not Schnarel alone) and Nason.

LG petitioned for *inter partes* review on September 26, 2015 after being sued for patent infringement in the Eastern District of Texas. LG challenged most of the same claims as Apple, asserting that claims 1, 2, 5–8, 10, 11, 13, and 16 of the ’020 patent and claims 1, 4–6, 8, 9, 20, 26, 27, and 29 of the ’476 patent were unpatentable as obvious over Blanchard and Schnarel (the “LG IPRs”). The Board instituted only on Blanchard.<sup>2</sup> On March 15, 2017, the Board issued its Final Written Decisions finding that LG failed to prove that Blanchard disclosed all limitations of the patents because Blanchard did not disclose the “limited list” limitation.

Conversant and LG timely appealed. Conversant argues that Schnarel fails to disclose the “unlaunched state” limitation and that a person of skill in the art would not be motivated to combine Schnarel with Aberg. LG argues that the Board wrongly construed the term “limited list”

---

<sup>2</sup> Five days prior to oral argument, LG submitted a notice of supplemental authority to address the effect of *SAS Institute, Inc. v. Iancu*, 138 S. Ct. 1348 (2018) on its appeal, arguing that, if we did not vacate and remand the Board’s decisions regarding Blanchard, we should remand for the Board to address Schnarel. We decline LG’s request. Not only is the request untimely since LG failed to justify its eight-month delay in raising the issue, but LG never filed a motion to remand predicated on *SAS*. The Board expressly found in the Apple IPR, moreover, that Schnarel standing alone did not render the challenged claims obvious.

and that Blanchard discloses that limitation. We have jurisdiction over both appeals pursuant to 35 U.S.C. § 141(c) and 28 U.S.C. § 1295(a)(4).

## II. STANDARD OF REVIEW

Claim construction and obviousness are questions of law with factual underpinnings. We, therefore, review the Board's ultimate legal conclusions *de novo* and any antecedent factual determinations for substantial evidence. *Teva Pharms. USA, Inc. v. Sandoz, Inc.*, 135 S. Ct. 831, 841 (2015); *Paice LLC v. Ford Motor Co.*, 881 F.3d 894, 902 (Fed. Cir. 2018).

Within the obviousness context, whether a motivation to combine references exists is a factual issue reviewed for substantial evidence. *See In re Hyon*, 679 F.3d 1363, 1365–66 (Fed. Cir. 2012); *In re NuVasive, Inc.*, 842 F.3d 1376, 1381–82 (Fed. Cir. 2016). Substantial evidence is “such relevant evidence as a reasonable mind might accept as adequate to support a conclusion.” *In re NuVasive*, 842 F.3d at 1379–80.

## III. DISCUSSION

### A. Conversant's Appeal

Conversant argues that the Board's Schnarel-based obviousness findings in the Apple IPRs suffer two flaws: (1) Schnarel does not disclose the “unlaunched state” limitation; and (2) a person of ordinary skill in the art would not be motivated to combine Schnarel with Aberg to satisfy the “reached directly” limitation. Neither argument is persuasive.

First, Conversant never argued before the Board that Schnarel does not disclose the “unlaunched state” limitation, despite Apple asserting that this limitation was disclosed by Schnarel in its petitions and despite the Board stating in its institution decisions that the parties' only dispute involved the “reached directly” limitation.

See J.A. 225, 312, 2630.<sup>3</sup> Conversant has, therefore, waived this argument on appeal.

Despite conceding during oral argument that it never raised this limitation below, Conversant contends that, because “th[e] issue was decided below,” it is preserved for appeal. Oral Argument at 5:40, *Conversant Wireless Licensing v. Apple Inc.*, <http://oralarguments.cafc.uscourts.gov/default.aspx?fl=2018-1185.mp3>; Conversant Reply Br. at 33. But, there was no issue for the Board to decide regarding whether this limitation was disclosed in Schnarel. As mentioned above, Apple asserted the limitation was satisfied and Conversant failed to contest that assertion. The Board, therefore, relied on Apple’s petitions in finding this limitation satisfied. J.A. 42, 114. An issue cannot be preserved for appeal merely because the Board finds it uncontested. See *In re NuVasive, Inc.*, 841 F.3d 966, 974 (Fed. Cir. 2016) (The Board is “not required to address undisputed matters” or arguments about limitations with which it was never presented.). And, while Conversant faults the Board for its limited analysis as to how Schnarel satisfies this limitation, the Board’s analysis is more than “commensurate with” Conversant’s treatment of the issue. See *Novartis AG v. Torrent Pharms. Ltd.*, 853 F.3d 1316, 1328 (Fed. Cir. 2017).

Second, substantial evidence supports the Board’s finding regarding the motivation to combine Schnarel and Aberg. The Board found that a person of ordinary skill in the art would have been motivated to reformat the mes-

---

<sup>3</sup> All references to the Joint Appendix in this subsection refer to *Conversant Wireless Licensing v. Apple Inc.*, No. 2018-1185 (Fed. Cir. Aug. 16, 2018), ECF No. 43, while all references to the Joint Appendix in the following subsection, see *infra* Section III.B, refer to *LG Electronics, Inc. v. Conversant Wireless Licensing*, No. 2017-2028 (Fed. Cir. Apr. 23, 2018), ECF No. 52.

sages pane of Schnarel into a “special” menu button, as disclosed in Aberg, placed in Schnarel’s application button bar “to deal with the problems of small screens.” J.A. 27, 100. The Board explained that this combination “would have retained many of the benefits of Schnarel’s messages pane” while allowing “it to be used with smaller screens.” J.A. 27, 100. It is undisputed that combining Schnarel with Aberg in this manner satisfies the “reached directly” limitation of the claims. Conversant only challenges whether a person of ordinary skill in the art would be motivated to combine these references in the first place. Conversant argues that the Board’s reasoning—that combining the references “deal[s] with the problems of small screens”—is inadequate because there is no support in either reference for (1) reformatting the message pane into a “special” button on the application button bar or (2) creating a button on the application button bar that, contrary to the other application bar buttons, would not launch a specific application. According to Conversant, the Board improperly relied on hindsight in reaching its conclusion. We disagree.

Schnarel and Aberg are both directed to solving problems associated with the limited screen display of mobile devices through summary presentation (e.g., in Schnarel, breaking the display into “panes” and in Aberg, using a hierarchical menu). *See* Schnarel, col. 1 ll. 19–20, 31–35; Aberg, col. 1 ll. 31–44, col. 2 ll. 36–40; *see also* J.A. 1161 (Apple’s expert testifying that the references are “in the same field of art (relating to GUIs/menu design) and teach displaying summary windows on mobile telephones that include different applications”). The fact that the references are directed to the same field of art helps to support the Board’s finding that a person of ordinary skill in the art would be motivated to combine their teachings in creating a device that would receive the benefits of Schnarel’s message pane while minimizing the amount of space used on the screen. *See Tyco Healthcare Grp. LP v.*

*Ethicon Endo-Surgery, Inc.*, 774 F.3d 968, 978 (Fed. Cir. 2014) (finding motivation to combine where references are “clearly within a common field of endeavor”). More specifically, as the Board found, Aberg’s “special” menu “fills the gap” left open by Schnarel by disclosing a way to minimize the space used by Schnarel’s message pane without losing the advantages associated therewith. *See* J.A. 27, 100; *see also* J.A. 213–15. Apple’s expert, moreover, opined that modifying Schnarel to utilize Aberg’s “special” menu was well within the level of skill in the art at the time of the invention, and that such a combination “would have amounted to a predictable variation resulting from design incentives, not any inventive concept.” J.A. 30, 103, 1162.

Conversant’s arguments to the contrary are not persuasive. While Conversant argues that there is no reason to place the “special” menu directly in Schnarel’s application button bar, Schnarel only discloses three areas—the message pane area, the application button bar, and the call slip area. Placing the “special” menu anywhere but the application button bar (or simply removing it as Conversant contends) would not advance either reference’s goal of decreasing screen usage while still allowing users to “quickly discover whether or not they have new messages and quickly access these new messages.” *See* Schnarel, col. 6 ll. 32–34. And, Aberg itself teaches that the “special” menu “may be located anywhere further down the menu hierarchy.” Aberg, col. 7 ll. 26–29.

That the “special” menu button would launch the message pane, not an application, does not negate the motivation to combine. Schnarel teaches that the “primary functions” of the application button bar “are to inform the user of all applications that are available to them and to provide a vehicle for launching those applications.” Schnarel, col. 9 ll. 4–6. Apple’s proposed combination satisfies these functions by using the “special” menu button to inform the user of available functions (the

message pane) and the ability to launch that function by clicking the button. Schnarel also discloses that the pane area, including the message pane, “is designed to allow customization” and that windows within the display may be “collapsed.” Schnarel, col. 3 ll. 14–17, col. 5 ll. 7–25, col. 9 ll. 35–40. Accordingly, we conclude substantial evidence supports the Board’s finding that a person of ordinary skill in the art would be motivated to combine Aberg’s “special” menu with Schnarel’s message pane, thereby satisfying the “reached directly” limitation of the claims.<sup>4</sup>

### B. LG’s Appeal<sup>5</sup>

On appeal, LG contends that the Board: (1) erroneously construed the term “limited list,” and

---

<sup>4</sup> Conversant does not raise any argument on appeal specific to the asserted dependent claims. We affirm the Board’s findings with respect to those claims as well.

<sup>5</sup> We recognize that our decision to affirm the Board’s findings in the Apple IPRs will impact the district court proceedings between LG and Conversant. *See Fresenius USA, Inc. v. Baxter Int’l, Inc.*, 721 F.3d 1330, 1340 (Fed. Cir. 2013). Given our decision, only certain dependent claims at issue in the LG IPRs remain patentable. And, of those remaining dependent claims, none are asserted against LG in the pending district court litigation between LG and Conversant. Conversant, thus, suggested at oral argument that, to the extent we affirm the Board’s decisions in the Apple IPRs, it may have no remaining stake in the LG appeal. Oral Argument at 11:25, *LG Elecs., Inc. v. Conversant Wireless Licensing*, <http://oralarguments.cafc.uscourts.gov/default.aspx?fl=2017-2028.mp3>. LG has not said the same about its own stake. Given that our decision in the Apple IPRs is not yet final, we choose to address the parties’ arguments regarding the LG IPRs.

(2) ignored evidence establishing that Blanchard discloses a “limited list” of functions or data as required by the claims. Conversant disagrees and further contends that the Board’s determinations can be affirmed on the separate ground that LG’s petitions were wholly conclusory.

In its Final Written Decisions, the Board found that “[n]either party propose[d] a construction” for the term “limited list,” but that both parties appeared to agree that it required that “any functions shown in the ‘limited list’ are fewer than all the functions available in an application.” J.A. 5–6; *see also* J.A. 22–23 (as to the ’476 patent, finding the parties to agree that the phrase required “fewer than all the data or functions available in an application”). Because that understanding was supported by the claims and specification, and because neither party disputed it, the Board adopted it as the proper construction. J.A. 6–7, 23–24. Turning to the merits, the Board found that LG failed to establish that Blanchard disclosed a “limited list” of data or functions, as LG failed to prove what other functions or data were offered by the applications disclosed in Blanchard. J.A. 10–14, 28–32.

LG has failed to prove that the asserted claims are unpatentable as obvious in light of Blanchard. First, the Board properly construed the term “limited list.” While LG contends that the phrase must be tied to what is displayed on a device screen, the claims, on their face, tether the “limited list” to the application summary window (or summary window), not the screen display. *See* ’020 patent, col. 5 ll. 38–40 (“... wherein the application summary window displays a limited list of at least one function offered within the first application”); ’476 patent, col. 5 ll. 63–65 (“... wherein the application summary displays a limited list of data offered within the one or more applications”). The specifications support this understanding and emphasize that “the summary does not have to be presented within any kind of frame.” *See* ’020 patent at col. 3 ll. 63–66. And, as the purpose of

the inventions are to allow a user to more efficiently view “common” or “core” functions or data without first navigating through various steps, it follows that the “limited list” be limited by which functions the user deems “common” or “core,” not by which functions can be viewed on one screen. Finally, as the Board acknowledged, both parties’ experts at least implicitly agreed on this construction. *See* J.A. 6, 23.

Second, applying this construction, the Board properly determined that LG failed to meet its burden to prove that Blanchard renders the asserted claims unpatentable. While LG contends that the Board ignored substantial evidence related to Blanchard’s disclosures, LG failed to present this evidence to the Board. And, the arguments LG did preserve rely on entirely conclusory petitions. *See* J.A. 70–71, 114–15. As the Board found, LG “provide[d] no evidence or argument tying the allegedly missing functions to any particular application or any particular application summary window” and, instead, asked the Board “to speculate about what Blanchard does and where those functions are offered.” J.A. 12, 29–30. Accordingly, we affirm the Board’s decisions upholding the patents in light of Blanchard.

#### IV. CONCLUSION

For the foregoing reasons, we *affirm* the Board’s determinations invalidating the Apple-challenged claims in light of Schnarel in combination with Aberg and upholding the LG-challenged claims over Blanchard.

#### **AFFIRMED**

#### COSTS

Costs to the appellees.