

NOTE: This disposition is nonprecedential.

**United States Court of Appeals
for the Federal Circuit**

VIATECH TECHNOLOGIES INC.,
Plaintiff-Appellant

v.

MICROSOFT CORPORATION,
Defendant-Appellee

2017-2276

Appeal from the United States District Court for the District of Delaware in No. 1:14-cv-01226-RGA, Judge Richard G. Andrews.

Decided: May 23, 2018

MICHAEL LENNON, Hunton Andrews Kurth LLP, New York, NY, argued for plaintiff-appellant. Also represented by SHEILA MORTAZAVI, GEORG CHRISTIAN REITBOECK.

FRANK SCHERKENBACH, Fish & Richardson, PC, Boston, MA, argued for defendant-appellee. Also represented by KURT LOUIS GLITZENSTEIN, STEVEN KATZ, WHITNEY A. REICHEL.

Before LOURIE, SCHALL, and CHEN, *Circuit Judges*.

CHEN, *Circuit Judge*.

SUMMARY

This case is appealed from the United States District Court for the District of Delaware, which granted summary judgment of non-infringement of ViaTech Technologies Inc.’s Patent No. 6,920,567 by several versions of Microsoft Corporation’s Windows and Office software.¹

The ’567 patent claims a file that contains the license to the content of the file as part of the file itself. Specifically, the ’567 patent covers a “digital content file” that contains “digital content,” a “dynamic license database” with the license information, and a “file access control mechanism” that interlinks the license information and the digital content. The patent also has related method claims.

ViaTech appeals the district court’s grant of summary judgment on the following contentions: (1) erroneous claim construction of the terms “file” and “dynamic license database”; (2) erroneous summary judgment of literal non-infringement due to outstanding disputed facts; and (3) erroneous summary judgment of non-infringement under the doctrine of equivalents, which the district court dismissed as waived.

Below, we clarify the constructions of “file” and “dynamic license database,” but find that even under these clarified constructions, (1) it is undisputed that the pre-installation version of Windows does not contain the “dynamic license database” element, and (2) ViaTech waived the argument that post-installation Windows is a

¹ The issues on appeal are substantially similar for both products. For simplicity, we refer to just “Windows” for the remainder of this opinion.

“file” by not squarely presenting it to the district court. We also find that the district court correctly found any doctrine of equivalents argument waived.

Thus, we *affirm*.

BACKGROUND

A. The '567 Patent

The '567 patent describes and claims systems and methods for distributing digital content files and controlling the licensed use of digital content included in those files. *See, e.g.*, '567 Patent, Abstract.

Prior art systems relied on licensing mechanisms that were separate and independent from the licensed content and had no effective functional relationship to the licensed program. *Id.* at col. 3, ll. 37–44. As a result, the licensed content was “vulnerable to various methods for bypassing such forms of protection.” *Id.* at col. 3, ll. 43–44. In addition, the licenses could not subsequently be modified once granted and the content became fully accessible to the user system. *Id.* at col. 3, ll. 44–52.

Addressing these disadvantages, the '567 patent describes and claims a “digital content file” that comprises a “file access control mechanism” including a “dynamic license database.” *Id.* at col. 3, l. 53–col. 4, l. 1. The file access control mechanism is embedded either physically or functionally, in the digital content file, and controls access to digital content based on the terms of the content’s corresponding license. *Id.* at col. 15, ll. 12–44. The database stores (1) the license terms and provisions which control access to the digital content of the file, and (2) the information controlling operations of the file access control mechanism. *Id.* at col. 3, l. 53–col. 4, l. 14.

As illustrated in Figure 1A of the '567 patent (annotated below), the digital content file DCF 10 includes DCF Content 10A, which can be either executable code or data.

Id. at col. 14, l. 66–col. 15, l. 11. The digital content file also has an embedded file access control mechanism FACM 12, which is either “directly and physically” or “functionally” part of the DCF 10. *Id.* at col. 15, ll. 43–45. The FACM 12 in turn includes the dynamic license database 14 and other components, for example, a license functions mechanism 16, that enforce the stored license terms. *Id.* at Fig. 1A, col. 10, ll. 24–65.

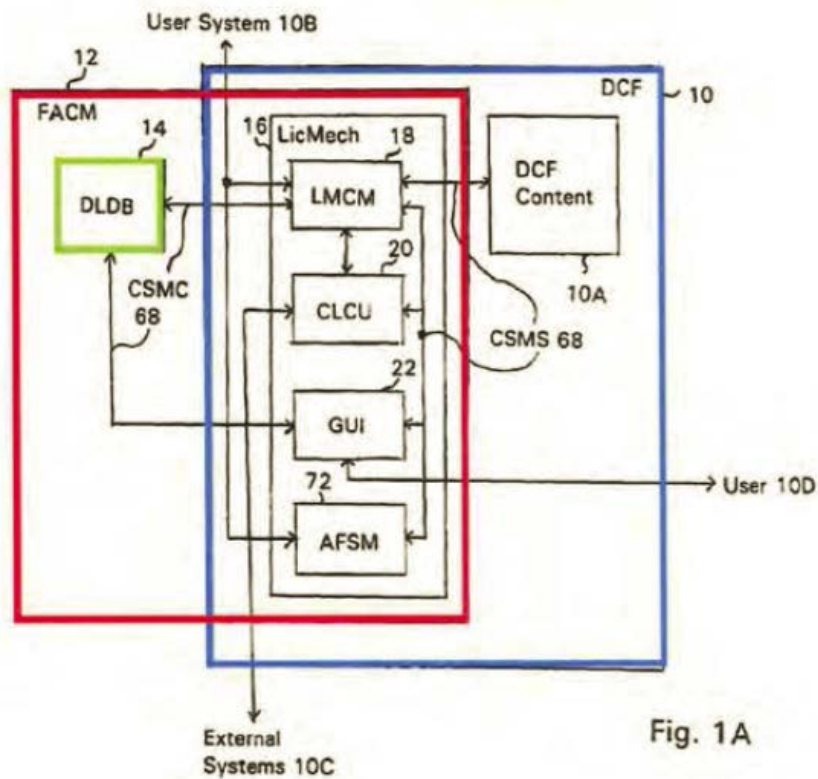

The specification describes this figure as a “diagrammatic representation[] of a file containing licensed digital content and an electronic license mechanism embedded therein according to the present invention.” *Id.* at col. 9, ll. 31–34.

B. Asserted Claims

In its complaint and infringement contentions, Vi-aTech alleged that Windows software infringes claims 1–7, 13–15, and 28–32 of the '567 patent. Claim 1 is independent in form, and is representative:

1. A digital content file including a license control mechanism for controlling the licensed use of digital content, comprising:

a digital content, and

an embedded file access control mechanism embedded in the digital content file, including

a license functions mechanism embedded in the digital content file and including

a license monitor and control mechanism communicating with a dynamic license database and monitoring use of the digital content by a user to determine whether a use of the digital content by a user complies with the license defined in the dynamic license database, and

a license control utility providing communications between a user system and an external system to communicate license definition information between the user system and the external system, including

a graphical user interface associated with the license control utility to provide communication between a user and user accessible functions of the license functions mechanism, and

the dynamic license database wherein the dynamic license database is associated with the digital content file for storing information controlling operations of the file access control mechanism and license information controlling licensed use of the digital content.

Id. at col. 40, l. 65–col. 41, l. 24. Claims 28 and 31 are independent method claims and include similar language regarding the claimed digital content file. *Id.* at col. 47, l. 43–col. 48, l. 29, col. 49, l. 26–col. 50, l. 30.

C. The Accused Products

ViaTech asserts that Microsoft’s Windows’s “Software Protection Platform” (SPP)² infringes the ’567 patent. Appellant’s Br. at 9. Certain SPP software components present in Windows store information, including the terms of a user’s license (e.g., a trial copy or otherwise). When Windows is installed on a user’s computer, the SPP code enforces those terms when the user attempts to access the software.

Specifically, ViaTech asserts that the “disk image” file used to install Windows on a user’s computer is the “digital content file” of the ’567 patent. Appellant’s Br. at 39; Appx2512, ¶4. The disk image file is a data file that contains an installer program and the Windows software in a compressed form.

ViaTech also asserts that the Token Store (a file named “tokens.dat”), the Trusted Store (a file named “data.dat”), and the Cache Store (a file named “cache.dat”) (collectively “Stores”), which are not present in the disk image file but come into existence post-installation, make up the “dynamic license database” of Windows. Appel-

² The corollary for Microsoft Office is “Office Software Protection Platform” (OSPP).

lant's Br. at 32–33. Each of these files is a data file. The Token Store stores licenses that must be activated by a remote Microsoft server. The Trusted Store stores product keys and other information. The Cache Store stores the results of a license check.

D. Issues on Appeal

In June 2016, the district court issued a claim construction order on ten terms. *ViaTech Tech. Inc. v. Microsoft Corp.*, No. CV 14-1226-RGA, 2016 WL 3398025 (D. Del. June 14, 2016). ViaTech appeals the district court's constructions of "dynamic license database" and "file."

For "dynamic license database," the district court adopted Microsoft's proposed construction of "a database that resides in the digital content file and that is programmed to accept modifiable licenses" over ViaTech's proposed construction of "a modifiable record into which file access control and licensed use information can be written." *Id.* at *5–6. At issue on appeal is whether the "resides in the digital content file" language of the adopted construction is supported by the patent specification and if the word "dynamic" describes a modifiable database or modifiable licenses within the claimed database.

For "file," the district court construed the term as its "plain and ordinary meaning, i.e., 'a collection of data that is treated as a unit by a file system.'" *Id.* at *6–7. At issue on appeal is whether this construction includes a collection of multiple files that is treated as a unit by a file system.

In June 2017, the district court granted summary judgment of non-infringement, finding that ViaTech "cannot establish the accused software infringes in any one state because [ViaTech] cannot prove the accused products meet the 'license database' and the 'file' limitations at the same time." *ViaTech Tech. Inc. v. Microsoft Corp.*, No. 14-CV-1226 (RGA), 2017 WL 2538570, at *4 (D.

Del. June 12, 2017). Specifically, the district court rejected the position that “file” could mean a collection of files, and not just a discrete file. *Id.* The district court then found that its construction of “file” put Plaintiff’s infringement theory “in a bind” because:

Post-installation, Windows is a collection of files, not a single file. Pre-installation, Windows is a “file.” Post-installation, the files [ViaTech] points to as the “license database”—the token store, the trusted store, and the cache store—exist. Pre-installation, they do not. [ViaTech]’s infringement position requires me to treat Windows in one form for one part of the claim and in another form for the other. I cannot do so.

Id. Having found that ViaTech lacked “any theory of infringement where the accused products meet all of the claimed limitations at the same time,” the district court granted summary judgment of non-infringement. *Id.* at *6. At issue on appeal is whether the district court erred in doing so.

In the same summary judgment order, the district court also found that ViaTech had “produced no evidence from which a factfinder could find infringement under the doctrine of equivalents” and granted summary judgment of no infringement under the doctrine of equivalents. *Id.* at *7. On appeal, ViaTech points to evidence in the record where it allegedly put forth its doctrine of equivalents theory and asks this court to reverse.

DISCUSSION

A. Claim Construction

The “ultimate question of the proper construction” of a patent claim is a question of law, and claim construction rulings are reviewed *de novo*. *Teva Pharm. USA, Inc. v. Sandoz, Inc.*, 789 F.3d 1335, 1339 (Fed. Cir. 2015). “To ascertain the scope and meaning of the asserted claims,

we look to the words of the claims themselves, the specification, the prosecution history, and, if necessary, any relevant extrinsic evidence.” *Chi. Bd. Options Exch., Inc. v. Int’l Sec. Exch., LLC*, 677 F.3d 1361, 1366 (Fed. Cir. 2012) (citation omitted). “[T]he specification is the single best guide to the meaning of a disputed term, and . . . acts as a dictionary when it expressly defines terms used in the claims or when it defines terms by implication.” *Phillips v. AWH Corp.*, 415 F.3d 1303, 1312, 1321 (Fed. Cir. 2005) (en banc) (internal quotation marks and citations omitted).

1. “Dynamic License Database”

We agree with ViaTech that the district court’s construction of “dynamic license database” is unsupported by the ’567 patent specification. The district court construed the term to mean “a database that resides in the digital content file and that is programmed to accept modifiable licenses.” *ViaTech Tech. Inc.*, 2016 WL 3398025, at *5.

But the ’567 specification has multiple examples of a database residing *outside* of the digital content file. See ’567 Patent, Figs. 1A, 1C (annotated to identify the database DLDB and digital content file DCF below).

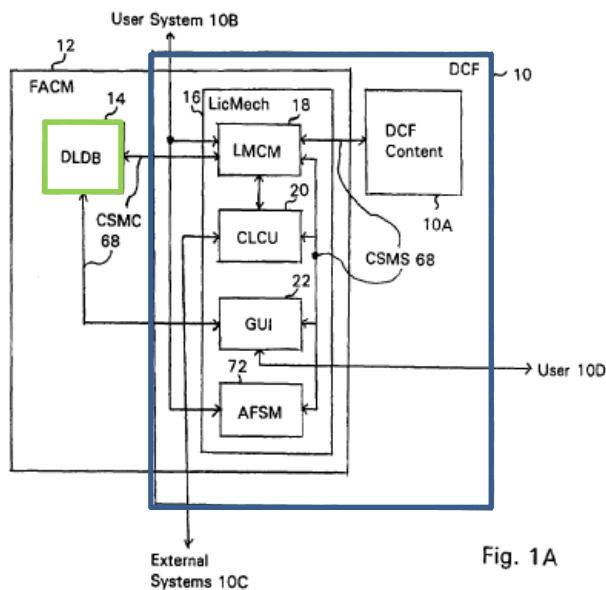

Fig. 1A

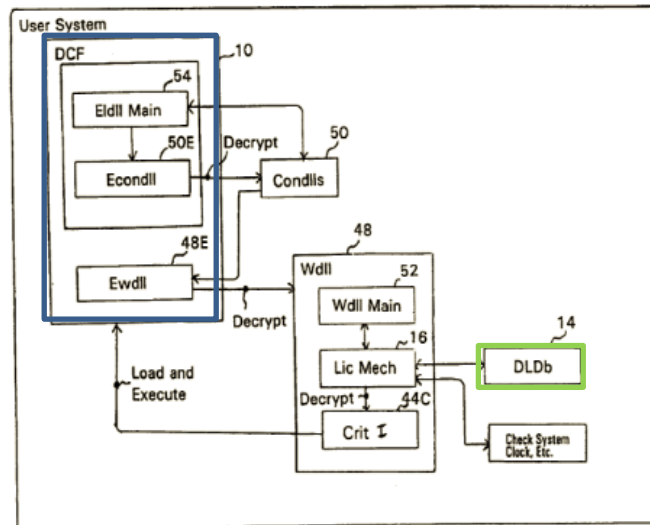

Fig. 1C

Further, the '567 patent specification uses the term “residing” to describe other relative relationships but never uses the term to describe the relationship between a dynamic license database and a digital content file. *See, e.g.*, '567 Patent at col. 2, l. 57 (“all license records reside in the license server”); *id.* at col. 4, l. 59 (referring to the license information as “residing in” the database); *id.* at col. 10, ll. 38–41 (“The DLDB is associated with the DCF, resides in a licensed user’s system and contains information and data controlling the operations of the FACM . . .”).

Instead, claims 1, 28 and 31 of the '567 Patent claim a database that is “associated with” the digital content file. *Id.* at col. 41, l. 22, col. 48, l. 2, col. 49, l. 35. We read “associated with” as the patent’s explanation of the relationship between the database and the file. By construing dynamic license database to be restricted to a structure that “resides in” a digital content file, the district court erred in translating this “associated with” claim language in an overly narrow manner. In fact, the district court’s erroneous construction defined “associated with” more

narrowly than the phrase “embedded in,” which is found elsewhere in the claim language and which the district court correctly construed to mean both a “part of or functionally included.” *ViaTech Tech. Inc.*, 2016 WL 3398025, at *4.

Microsoft argues that the preamble language of Claims 1, 28 and 31, “comprising,” “containing,” and “including” respectively, require that all the subsequent recited claim elements “reside in” the claimed “digital content file.” We do not agree. Doing so would render the “embedded in” and “associated with” language in those claims superfluous, and a “claim construction that gives meaning to all the terms of the claim is preferred over one that does not do so.” *Merck & Co. v. Teva Pharm. USA, Inc.*, 395 F.3d 1364, 1372 (Fed. Cir. 2005); *see also In re Power Integrations, Inc.*, 884 F.3d at 1376. In the context of claim 1, the better reading of the final paragraph relating to the “the dynamic license database” is that it recites the required functional relationship between the database and the digital content file, not that the database necessarily resides in the digital content file.

We also do not agree with the district court’s conclusion that “dynamic” in “dynamic license database” defines the license rather than the database. We agree with the district court that the patent specification discusses modifiable, non-static licenses. *ViaTech Tech. Inc.*, 2016 WL 3398025, at *6. However, we also share ViaTech’s concern that the construction “programmed to accept modifiable licenses” is too narrow because it excludes other disclosed embodiments where the database is modified when licenses are “dynamically creat[ed] [or] acquir[ed].” *See, e.g.*, ’567 Patent, col. 13, ll. 7–15. Reading the word “dynamic” to describe “database” fixes the issue: a database with modifiable licenses is necessarily a modifiable database, encompassing the district court’s understanding, but a modifiable database also encompasses the

disclosure of a database that can create or acquire new licenses.

The patent specification supports our alteration of the district court’s construction of “dynamic license database.” The specification describes the “dynamic license database” as a modifiable database storing file access control and license use data. A dynamic license database is “associated with the digital content file for storing information controlling operations of the file access control mechanism and license information controlling licensed use of the digital content.” ’567 Patent, col. 3, l. 65–col. 4, l. 1. It “is a local, resident database record containing eLicense control parameters,” and is “designed to be extensible for forward and backward compatibility, to allow record fields to be added or subtracted without interfering with existing data management, and to allow future expansion to contain virtually any data relevant to software licensing and asset management.” *Id.* at col. 20, ll. 36–38, 53–58. Users may access such a dynamic license database “to dynamically create, acquire, update and modify eLicenses.” *Id.* at col. 13, ll. 12–13.

The specification also refers to the data being written into the database. “[T]he eLicense data residing in the Dldb 14 is read by the LMCM 18 and data is thereafter written back into the Dldb 14 as appropriate.” *Id.* at col. 37, ll. 7–9. “The ELDP 82 data is written to the Dldb 14, and the 25 DCF 10 is fully licensed on the user system according to the limits and behavior set by the publisher.” *Id.* at col. 31, ll. 25–27.

We find that the patent specification supports Vi-aTech’s proposed construction of “dynamic license database” with a slight modification and construe the term to

mean “a modifiable database in which file access control and license use information is stored and can be written.”³

2. “File”

The district court construed file as “a collection of data that is treated as a unit by a file system.” *ViaTech Tech. Inc.*, 2016 WL 3398025, at *6. The district court then applied the construction to Microsoft Windows and found that pre-installation, the disk image file version of Windows is a “file,” but that post-installation, “Windows is a collection of files, not a single file.” *ViaTech Tech. Inc.*, 2017 WL 2538570, at *5.

We do not agree that a collection of files cannot be a “file” under the district court’s construction. By definition of its components, the claimed digital content file necessarily can be made up of multiple files. The digital content file has an embedded “file access control mechanism” and is associated with a “dynamic license database.” ’567 Patent, Abstract. In its claim construction order, the district court acknowledged that the file access control mechanism “can consist of many files.” *ViaTech Tech. Inc.*, 2016 WL 3398025, at *6. And the database associated with the claimed digital content file has license files and other use information within it. ’567 patent, col. 20, l. 33–col. 22, l. 46. Microsoft even admits that each element of the digital content file could be its own file. Oral Ar. 25:20–27:25. Further, the “disk image file” of Windows that the district court found to be a “file” contains the

³ At oral argument, ViaTech alleged that the parties agreed that a “database” would be defined as a “collection of records containing information.” Oral Arg. at 5:40–5:55. We do not see evidence of such a stipulation in the record before us. Therefore, we leave the construction of the term “database” open, should future parties contest the meaning of the term.

numerous files that make up Windows and Office. 2017 WL 2538570, at *4; Appx3433–34 at 137:3–139:14.

Both ViaTech and Microsoft agree that such “container files” can be a “file” as the term is used in the ’567 patent. Appx2501–02 (Microsoft Expert Testimony); Appx1172 (ViaTech Expert Testimony); Oral Arg. 23:59–24:26 (Microsoft’s admission during appellate argument). Microsoft’s expert’s analogy is illustrative: a large box with smaller boxes in it would still be considered a single package. Appx2502. Similarly, a file with multiple files within it can still be “a collection of data treated as a unit by a file system.”

This understanding of “file” does not require changing the district court’s construction, only its application of that construction. Thus, we uphold the district court’s construction, but clarify that a “file” as claimed in the ’567 patent may be a collection of files.

B. Summary Judgment

A district court’s grant of summary judgment is reviewed in accordance with the law of the regional circuit. *Profectus Tech. LLC v. Huawei Techs. Co.*, 823 F.3d 1375, 1379 (Fed. Cir. 2016). The District of Delaware is in the Third Circuit, which reviews a grant of summary judgment *de novo*. *Chimie v. PPG Indus., Inc.*, 402 F.3d 1371, 1376 (Fed. Cir. 2005). Here, Microsoft is “entitled to a judgment as a matter of law” if ViaTech, as the party with the burden of proving infringement, “has failed to make a sufficient showing on an essential element of [its] case with respect to which [it] has the burden of proof.” *Celotex Corp. v. Catrett*, 477 U.S. 317, 323 (1986).

Despite changing the construction of “dynamic license database” and clarifying the district court’s construction of “file” above, we find that these modifications do not affect the reasoning or outcome of the district court’s summary judgment order.

1. Pre-Installation Windows

For the pre-installation version of Windows, there is no dispute that the disk image file containing all the files and code of the Windows software is a “file.”

There is also no dispute that there is no dynamic license database in the pre-installation version of Windows. ViaTech asserts that the Stores in Windows are the claimed dynamic license database. But ViaTech also acknowledges that in the pre-installation disk image file of Windows, there is only code for the Stores and separate data files containing the licenses, and that the Stores themselves are created only upon installation. Appellant Br. at 40; Oral Arg. at 7:05–7:11. The pre-installation version of Windows thus lacks a database.

ViaTech argues that the presence of executable code with the capability of becoming the Stores upon installation meets the database element for the pre-installation product. However, the cases cited by ViaTech are inapplicable here. The claim language of the ’567 patent requires the presence of a database, not simple “capability” like the claims in *Versata Software, Inc. v. SAP America, Inc.*, 717 F.3d 1255, 1262–63 (Fed. Cir. 2013), or functional language like the claims in *Ericsson, Inc. v. D-Link Systems, Inc.*, 773 F.3d 1201, 1215–17 (Fed. Cir. 2014). Nor is there evidence here that the accused device was ever placed in an infringing configuration, unlike the software in *Fantasy Sports Properties v. Sportsline.com, Inc.*, which infringed upon installation and user activation. 287 F.3d 1108, 1118–19 (Fed. Cir. 2002). The lack of an infringing configuration on claims not drawn to capability resulted in a reversal of summary judgment of infringement in *Ball Aerosol and Specialty Container, Inc. v. Limited Brands, Inc.*, 555 F.3d 984, 994–95 (Fed. Cir. 2009). The same reasoning applies here: the ’567 patent can only be infringed if the digital content file is associated with an actual database as the claim requires. A

product having the capability of producing a database, e.g., containing the code and raw license data of a database, is not enough.

The claim language requires the presence of a database associated with the digital content file, and it is undisputed that there is no database, under the district court's construction or this court's revised construction, in pre-installation Windows.

2. Post-Installation Windows

For the post-installation version of Windows, the district court found that Windows existed as a "collection of files" after installation. While we disagree with the district court's articulation that a collection of files cannot be a "file" as claimed by the '567 patent, we agree with the district court that ViaTech never articulated a clear argument that post-installation Windows is a file. *ViaTech Tech. Inc.*, 2017 WL 2538570, at *3, n.5.

ViaTech's argument in summary judgment briefing focused on Windows software being treated as a unit by a file system because "it is distributed on a disk, or in a file-based disk image format, that can be mounted by the file system on a user's computer in order to install the software." Appx2512, 2520. This is a pre-installation "disk image file" argument.

ViaTech only documented the argument that post-installation Windows could be a file in two places: (1) footnote 26 of its Opposition to Summary Judgment and (2) in the four paragraphs of ViaTech's expert report discussing post-installation Windows. Appx2520 ("The Windows and Office software is also treated as a unit after installation because, e.g., the software invokes functions of the file system to locate and execute code residing in other Windows and Office 'files'"); Appx2662–63, ¶¶46, 48–50. When asked at oral argument before the district court where this post-installation

file argument had been presented, ViaTech could only point to these two sources. Appx7998.

Arguments that were not properly presented to the district court are waived on appeal. *Sage Prods., Inc. v. Devon Indus., Inc.*, 126 F.3d 1420, 1426 (Fed. Cir. 1997). As a threshold matter, a single footnote is insufficient to present a distinct infringement theory to the district court. *See SmithKline Beecham Corp. v. Apotex Corp.*, 439 F.3d 1312, 1320 (Fed. Cir. 2006). Here, the footnote did not even present a distinct alternative infringement theory: there is no element by element analysis of a post-installation version of Windows, or even a statement that the post-installation version is a file that infringes the '567 patent too. And regarding the four unquoted, uncited paragraphs of ViaTech's 147 paragraph expert report, ViaTech agrees that the district court was not obligated to address theories presented in an expert report when the theories were not raised or cited in briefing before the court. Oral Arg. 13:04–13:58; *see also Pandrol USA, LP v. Airboss Ry. Prod., Inc.*, 320 F.3d 1354, 1366 (Fed. Cir. 2003) (“There is no onus on the district court to distill any possible argument which could be made based on the materials before the court. Presenting such arguments in opposition to a motion for summary judgment is the responsibility of the non-moving party, not the court.”) (citation omitted).

We agree with the district court that ViaTech did not properly present or preserve the argument that post-installation Windows is a file and affirm the district court's waiver finding.

C. Doctrine of Equivalents

The district court also granted summary judgment of no infringement under doctrine of equivalents on waiver grounds.

“To prove infringement under the doctrine of equivalents, a plaintiff must show that an asserted equivalent represents an ‘insubstantial difference’ from the claimed element, or ‘whether the substitute element matches the function, way, and result of the claimed element.’” *Deere & Co. v. Bush Hog, LLC*, 703 F.3d 1349, 1356 (Fed. Cir. 2012) (citing *Warner-Jenkinson Co. v. Hilton Davis Chem. Co.*, 520 U.S. 17, 40 (1997)). The doctrine “must be applied to individual elements of the claim,” and each element “must be presented in the form of particularized testimony and linking argument.” *Warner-Jenkinson Co.*, 520 U.S. at 29; *Lear Siegler, Inc. v. Sealy Mattress Co. of Mich., Inc.*, 873 F.2d 1422, 1425–26 (Fed. Cir. 1989).

As evidence of its doctrine of equivalents theory, ViaTech points to deposition testimony of its expert, Dr. Goldberg, and excerpts from Dr. Goldberg’s expert report.

In deposition, Dr. Goldberg stated, “I see no reason why the opinions rendered in my Opening Expert Report and in this Reply Expert Report would not be relevant to . . . infringement under the doctrine of equivalents.” Appx3196. We read this as ViaTech merely reasserting its literal infringement arguments as doctrine of equivalents argument, which is insufficient to present a separate infringement theory under the doctrine. *nCube Corp. v. Seachange Int’l, Inc.*, 436 F.3d 1317, 1325 (Fed. Cir. 2006) (“The party asserting infringement must present ‘*evidence and argument concerning the doctrine and each of its elements.*’ The evidence and argument on the doctrine of equivalents cannot merely be subsumed in plaintiff’s case of literal infringement.”) (quoting *Lear Siegler Inc.*, 873 F.2d at 1425).

The excerpts from Dr. Goldberg’s expert report were dropped in a footnote on the very last page of ViaTech’s summary judgment briefing, accompanying text that *reserves* ViaTech’s right to assert infringement under the doctrine of equivalents, rather than actually presenting

any such argument. Appx2528.⁴ The district court would have been within its discretion to not even consider the footnote assertion. *See SmithKline Beecham Corp.*, 439 F.3d at 1320 (“[A]rguments raised in footnotes are not preserved” or properly raised). But the district court discretionarily looked to the substance of the paragraphs anyway and found that none “provide[d] a basis for Dr. Goldberg to opine that there is a substantial identity of function, means, and results” as required under the doctrine of equivalents. *ViaTech Tech. Inc.*, 2017 WL 2538570, at *7. We agree.

In its appeal to this court, ViaTech does not point to any briefing where it made a substantive doctrine of equivalents argument. Rather, ViaTech’s argument on appeal is that the district court changed its construction of “file” in its summary judgment to exclude a plurality of files, and therefore, ViaTech should now be permitted to assert infringement under the doctrine of equivalents in view of the updated constructions of the claims.

We do not agree. Even though this court clarifies the construction of “file” *supra*, the district court’s claim construction order was clear that the patent “never refers to a collection of files as a single ‘file’” and “suggests that the term ‘file’ is being used in its ordinary sense to mean a discrete, named entity.” *ViaTech Tech. Inc.*, 2016 WL3398025, at *6. ViaTech thus was on notice that the

⁴ ViaTech was similarly silent on the matter in its infringement contentions, save for a catch-all statement that “[t]o the extent that Microsoft subsequently identifies with specificity the elements of the asserted claims it contends are not present in the accused Windows and Office software products, ViaTech reserves the right to supplement this response to specifically address those contentions, including by asserting infringement under the doctrine of equivalents.” Appx8314–15.

district court would follow through with this understanding for the construction and application of “file,” and should have made any doctrine of equivalents argument during discovery, or at least well before trial was “merely weeks away.” *ViaTech Tech. Inc.*, 2017 WL 2538570, at *7; see *Kyocera Wireless Corp. v. Int’l Trade Com’n.*, 545 F.3d 1340, 1352 (Fed. Cir. 2008) (affirming lower tribunal’s finding that patent owner waived an argument by failing to raise it in a timely manner).⁵

ViaTech failed to articulate a theory of infringement under the doctrine of equivalents to the district court, and the district court correctly found waiver of the issue.

CONCLUSION

While we revise the district court’s construction of the terms “dynamic license database” and “file,” we find that ViaTech did not meet its burden of providing argument or evidence of an infringing configuration of Windows sufficient to survive summary judgment of literal non-infringement. We also find that ViaTech waived any argument under the doctrine of equivalents by failing to present the argument to the district court. We therefore affirm the district court’s summary judgment of non-infringement.

AFFIRMED

⁵ This court has previously affirmed a similar district court finding where the plaintiff “waived its right to raise the doctrine of equivalents by failing to timely disclose it as an infringement theory” in *Teashot LLC v. Green Mountain Coffee Roasters, Inc.*, 595 F. App’x 983, 987 (Fed. Cir. 2015).