

1
2
3
4
5
6
7
8
9
10
11
12
13
14
15
16
17
18
19
20
21
22
23
24
25
26
27
28

Larry Zerner (SBN 155473)
ZernerLaw
1801 Century Park East, Suite 2400
Los Angeles, California 90067
Telephone: (310) 773-3623
Facsimile: (310) 388-5624

Attorney for Defendant Mark Towle,
An individual and d/b/a Gotham Garage

UNITED STATES DISTRICT COURT
CENTRAL DISTRICT OF CALIFORNIA

DC Comics,

Plaintiff,

v.

Mark Towle, an individual and d/b/a
Gotham Garage, and Does 1 – 10,
inclusive,

Defendants.

} Case No. CV11-3934 RSWL (OPx)
} REQUEST FOR JUDICIAL
} NOTICE
} HEARING DATE: January 25, 2012
} TIME: 10:00 a.m.
} COURTROOM: 21
} BEFORE THE HONORABLE
} RONALD S.W. LEW

Pursuant to Federal Rules of Evidence 201, Defendant Mark Towle
respectfully requests that the Court take judicial notice of the following items.

1. Photographs of the Batmobile from the 1966 Television Series (Exhibit 1).
2. Photographs of the Batmobile from the 1989 Motion Picture (Exhibit 2).
3. Photographs of the Batmobile from the 1995 Motion Picture (Exhibit 3).
4. Copyright Registration Record for the “Hi, Diddle Riddle” episode of the
1966 Batman Television Series (Exhibit 4).

- 1 5. Copyright Registration Record for the 1989 Batman Motion Picture
2 (Exhibit 5).
- 3
- 4 6. Copyright Registration Record for the 1989 *Batman* Motion Picture
5 (Exhibit 6).
- 6
- 7 7. Copyright Registration Record for the 1995 *Batman Forever* Motion
8 Picture (Exhibit 7).
- 9
- 10 8. Copyright Registration Record for the 1997 *Batman & Robin* Motion
11 Picture (Exhibit 8).
- 12
- 13 9. Copyright Registration Record for the 2008 *Dark Knight* Motion Picture
14 (Exhibit 9).
- 15
- 16 10. Pages from the comic book *Batman* #170 (March 1965) which depict the
17 Batmobile (Exhibit 10).
- 18
- 19 11. Pages from the comic book *Detective* #337 (March 1965) which depict the
20 Batmobile (Exhibit 11).
- 21
- 22 12. Design Patent 205,998 for the 1966 Batmobile (Exhibit 12).
- 23 13. Design Patent 311,882 for the 1989 Batmobile (Exhibit 13).
- 24 14. Design Patent 375,704 for the 1995 Batmobile (Exhibit 14).

25 Federal Rule of Evidence 201(b) provides that a court may take judicial notice
26 of a fact “not subject to reasonable dispute in that it is either (1) generally known
27 within the territorial jurisdiction of the trial court or (2) capable of accurate and
28 ready determination by resort to sources whose accuracy cannot be reasonably

1 questioned.” Accordingly, this Court can and should consider them in deciding
2 Plaintiffs’ Motion for Preliminary Injunction.
3

4 As Plaintiff has alleged the Batmobiles are extremely famous vehicles and
5 recognizable the world over, the court can take judicial notice of these photographs
6 of these vehicles as there is no dispute as to what they look like.
7

8 Similarly, with regard to the comic books, Plaintiff specifically referenced
9 them in Exhibit A to the FAC and therefore the court may review them. Documents
10 not physically attached to the complaint may nonetheless be considered by the court
11 on a 12(b)(6) motion if (1) the complaint refers to such document; (2) the document
12 is central to plaintiff’s claim; and (3) no party questions the authenticity of the copy
13 attached to the 12(b)(6) motion. *Branch v. Tunnell*, 14 F.3d 449, 454 (9th Cir. 1994);
14 *Chambers v. Time Warner, Inc.* 282 F.3d 147, 153, fn. 3 (2nd Cir. 2002).
15
16

17 With regard to the copyright records and the patent records, the court may
18 properly consider matters of public record. All of the copyright registrations and
19 patent registrations are matters of public record and the court may therefore take
20 judicial notice of them.
21

22 Accordingly, this Court can and should consider all of these documents in
23 deciding Defendant’s Motion to Dismiss.
24

25 Based upon the foregoing, this Court can and should take judicial notice of
26 each of the documents described above and attached as exhibits hereto.
27
28

1
2
3
4
5
6
7
8
9
10
11
12
13
14
15
16
17
18
19
20
21
22
23
24
25
26
27
28

Date: December 16, 2011

Law Office of Larry Zerner

By: /Larry Zerner/_____

Larry Zerner

Attorney for Plaintiff



EXHIBIT 1

EXHIBIT 1

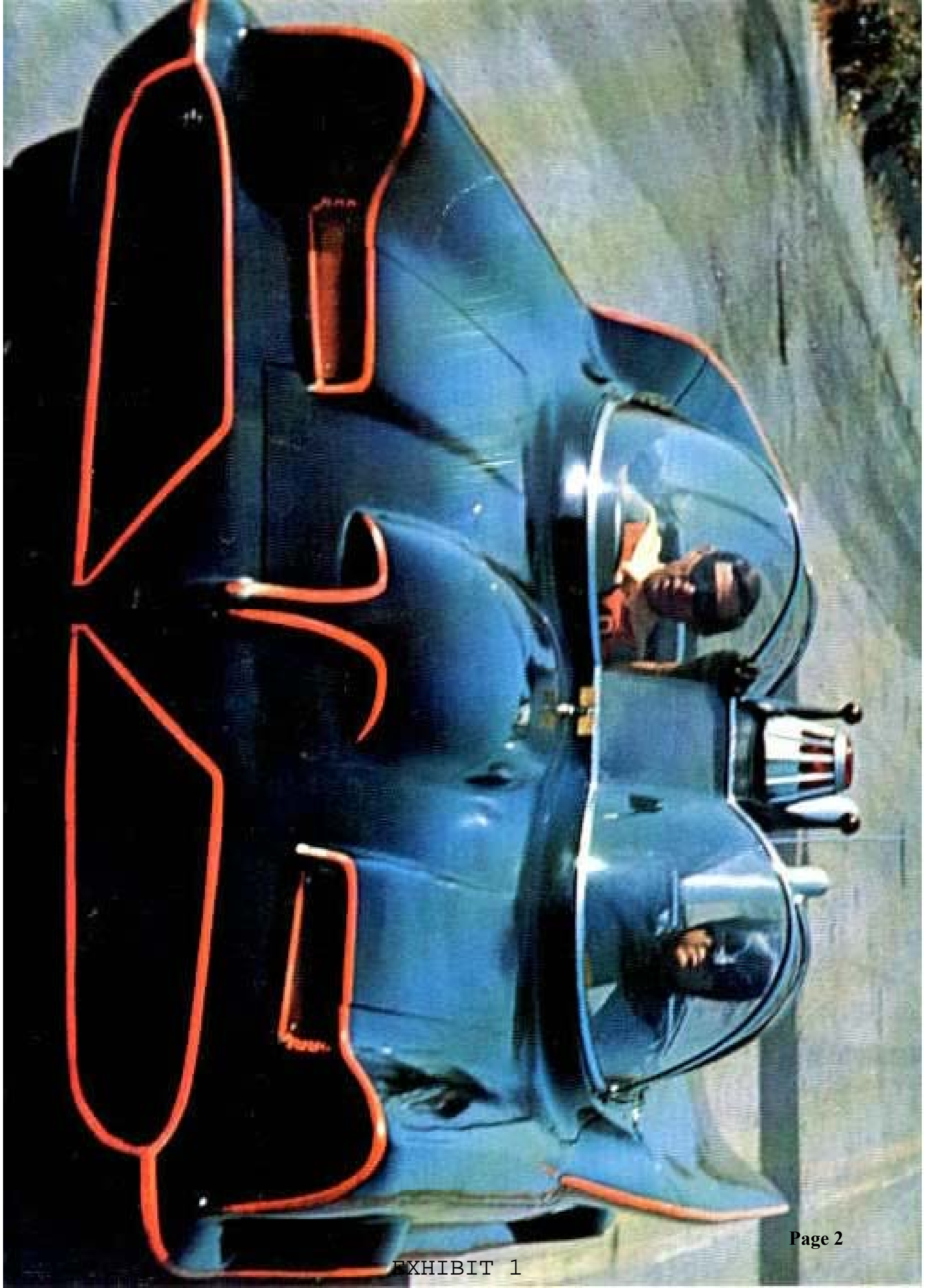

The Chris Kordes Collection

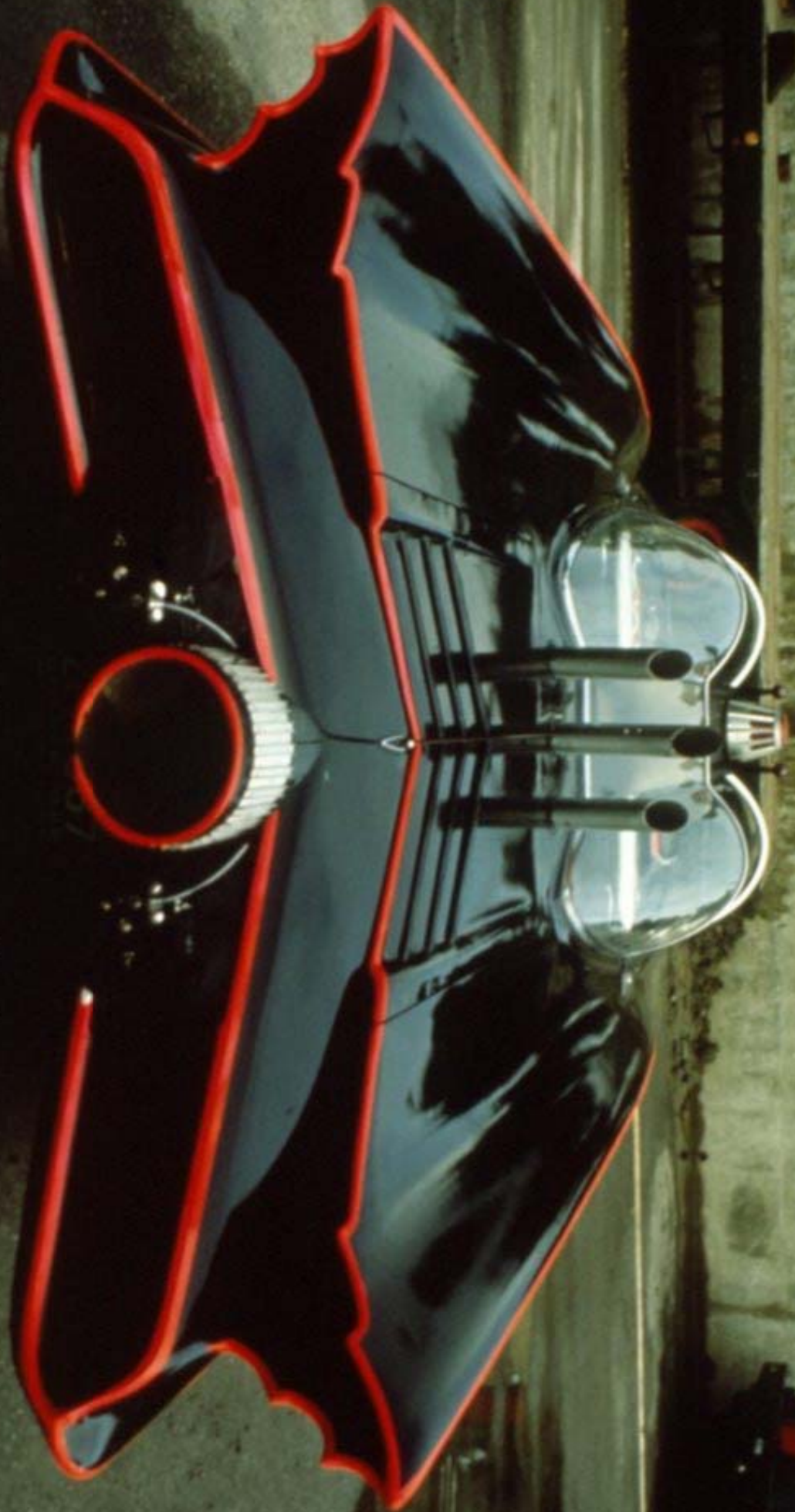
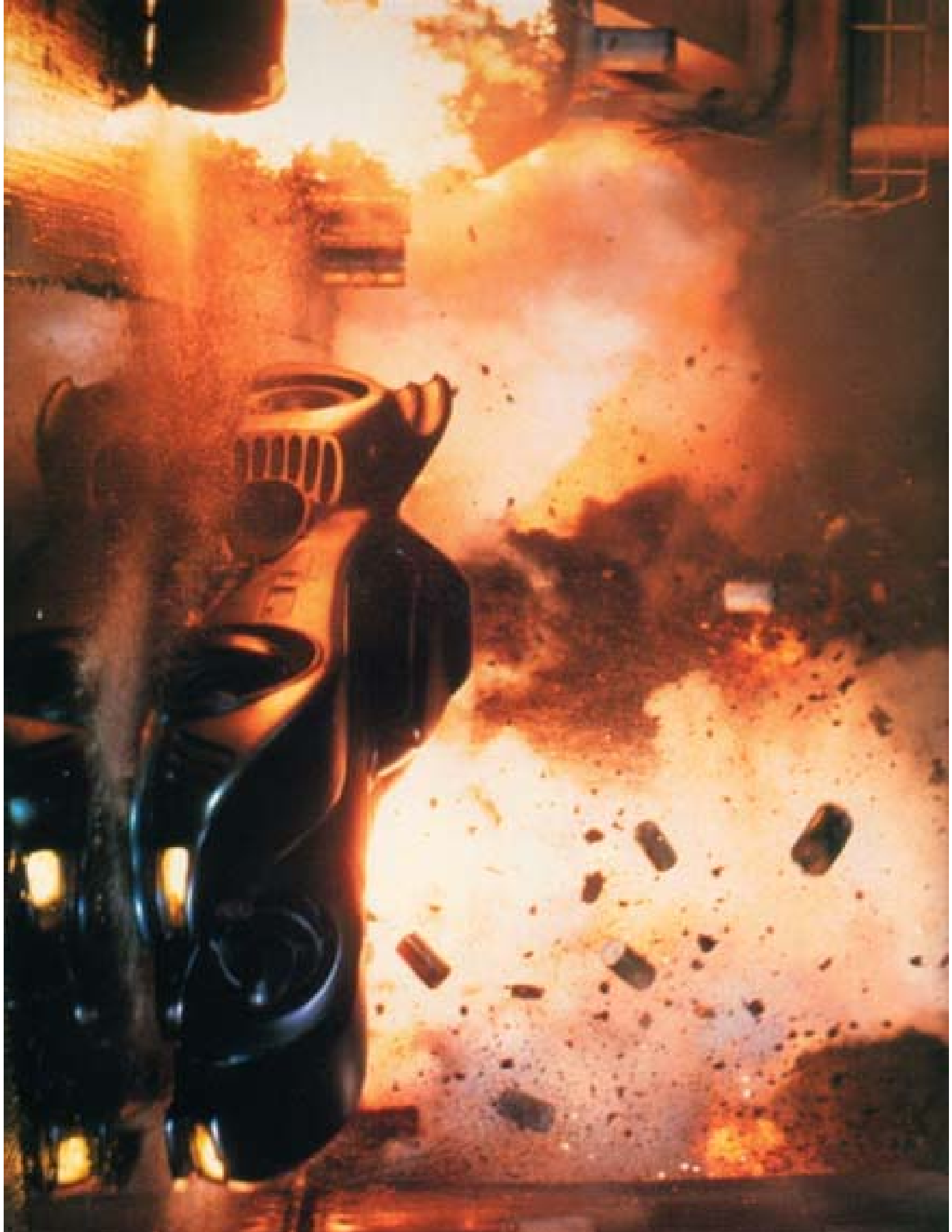

EXHIBIT 1

EXHIBIT 1



EXHIBIT 1







Public Catalog

Copyright Catalog (1978 to present)

Search Request: Builder = (batman)[in Title]AND(1966)[in Keyword Anywhere]

Search Results: Displaying 56 of 218 entries

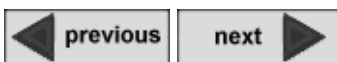

Labeled View

Batman : prod. no. 6028, Hi, diddle riddle.

Type of Work: Motion Picture

Registration Number / Date: PA0000269659 / 1985-10-08

Title: Batman : prod. no. 6028, Hi, diddle riddle.

Imprint: [Beverly Hills] : Greenway Productions, c1966.

Description: 1 videocassette : sd., col. ; 3/4 in.

Cast: Adam West, Burt Ward, Frank Gorshin et al.

Credits: A Greenway production in association with Twentieth Century-Fox Television; produced by William Dozier; directed by Robert Butler; written by Lorenzo Semple, Jr.

Copyright Claimant: Greenway Productions, Inc., & Twentieth Century-Fox Television, Inc.

Date of Creation: 1966

Date of Publication: 1966-05-02

Authorship on Application: Greenway Productions, Inc., & Twentieth Century-Fox Television, Inc., employers for hire.

Copyright Note: C.O. correspondence.

Variant title: Batman : prod. no. 6028

Other Title: Hi, diddle riddle

Names: Dozier, William

Butler, Robert

Greenway Productions, Inc.

Twentieth Century-Fox Television, Inc.

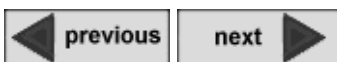

Save, Print and Email (Help Page)

Select Download Format Full Record

Enter your email address:

[Help](#)
[Search](#)
[History](#)
[Titles](#)
[Start Over](#)

Public Catalog

Copyright Catalog (1978 to present)

Search Request: Builder = (BATMAN)[in Title]AND(WARNER)[in Name: Claimant]

Search Results: Displaying 59 of 342 entries



Labeled View

Batman / a Guber-Peters Company production ; produced by Jon Peters and...

Type of Work: Motion Picture

Registration Number / Date: PA0000417162 / 1989-07-07

Title: Batman / a Guber-Peters Company production ; produced by Jon Peters and Peter Guber ; directed by Tim Burton.

Description: 7 film reels : sd., col. ; 35 mm.

Copyright Claimant: Warner Brothers, Inc.

Date of Creation: 1989

Date of Publication: 1989-06-19

Authorship on Application: Warner Brothers, Inc., employer for hire.

Previous Registration: Preexisting material: Batman comic book series, Batman television series, screenplay, sound recordings.

Basis of Claim: New Matter: "motion picture, including audio, visual, and other cinematographic material."

Names: Peters, Jon

Guber, Peter

Burton, Tim

Guber-Peters Company

Warner Brothers, Inc.



Save, Print and Email ([Help Page](#))

Select Download Format Full Record

Enter your email address:

Public Catalog

Copyright Catalog (1978 to present)

Search Request: Builder = (BATMAN)[in Title]AND(WARNER)[in Name: Claimant]

Search Results: Displaying 128 of 342 entries

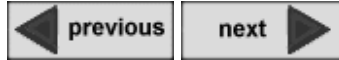

Labeled View

Batman forever / a Tim Burton production ; directed by Joel Schumacher.

Type of Work: Motion Picture

Registration Number / Date: PA0000720192 / 1995-06-26

Title: Batman forever / a Tim Burton production ; directed by Joel Schumacher.

Description: 6 film reels ; 35 mm.

Notes: Based on Batman comic book series.

Copyright Claimant: Warner Brothers, a division of Time Warner Entertainment Company, LP

Date of Creation: 1995

Date of Publication: 1995-06-16

Previous Registration: Screenplay & sound recordings preexisting.

Basis of Claim: New Matter: motion picture, including audio, visual and other cinematographic material.

Names: Burton, Tim

Schumacher, Joel

Warner Brothers

Time Warner Entertainment Company, LP. Warner Brothers



Save, Print and Email (Help Page)

Select Download Format Full Record

Enter your email address:

Public Catalog

Copyright Catalog (1978 to present)

Search Request: Builder = (BATMAN)[in Title]AND(WARNER)[in Name: Claimant]

Search Results: Displaying 27 of 342 entries

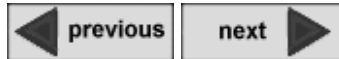

Labeled View

Batman & Robin / a Joel Schumacher film production ; directed by Joel...

Type of Work: Motion Picture

Registration Number / Date: PA0000859518 / 1997-07-14

Title: Batman & Robin / a Joel Schumacher film production ; directed by Joel Schumacher.

Description: 6 film reels ; 35 mm.

Copyright Claimant: Warner Brothers, a division of Time Warner Entertainment Company, LP (employer for hire)

Date of Creation: 1997

Date of Publication: 1997-06-20

Previous Registration: Screenplay, some film footage, 7 sound recordings & Batman characters from the comic books preexisting.

Basis of Claim: New Matter: motion picture and other cinematographic material.

Names: [Schumacher, Joel](#)

[Warner Brothers](#)

[Time Warner Entertainment Company, LP. Warner Brothers](#)



Save, Print and Email (Help Page)

Select Download Format Full Record

Enter your email address:

[Help](#)
[Search](#)
[History](#)
[Titles](#)
[Start Over](#)

Public Catalog

Copyright Catalog (1978 to present)

Search Request: Builder = (BATMAN)[in Title]AND(WARNER)[in Name: Claimant]

Search Results: Displaying 238 of 342 entries



Labeled View

THE DARK KNIGHT.

Type of Work: Motion Picture

Registration Number / Date: PA0001606857 / 2008-09-26

Application Title: THE DARK KNIGHT.

Title: THE DARK KNIGHT.

Description: 7 Film reels ; 35mm.

Copyright Claimant: Warner Bros. Entertainment Inc., Transfer: By Assignment. Address: 4000 Warner Boulevard, Burbank, California 91522

Date of Creation: 2008

Date of Publication: 2008-07-16

Nation of First Publication: Australia

Authorship on Application: Warner Bros. Pictures, a division of WB Studio Enterprises Inc., employer for hire; Domicile: United States. Authorship: ENTIRE WORK.

Alternative Title on Application: BATMAN BEGINS 2 aka RORY'S FIRST KISS

Previous Registration: 2008, PRE000001409.

Pre-existing Material: Based on the BATMAN characters created by Bob Kane and published by DC Comics. Screenplay entitled THE DARK KNIGHT by Jonathan Nolan and Christopher Nolan. Certain photographs and sound recordings.

Basis of Claim: Motion picture, including audio, visual and other cinematographic material.

Names: Nolan, Christopher

Warner Bros. Pictures

WB Studio Enterprises Inc.

Warner Bros. Entertainment Inc.

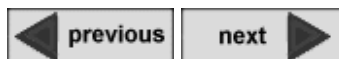

Save, Print and Email ([Help Page](#))



12¢

MAR. NO. 170



BATMAN

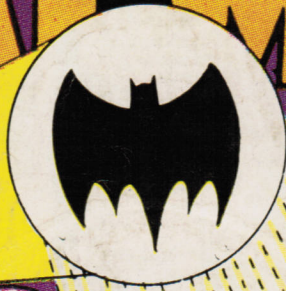

THE BAT-SYMBOL ON *BATMAN'S* UNIFORM HAS EXPANDED INTO A STRAIT JACKET--PINNING HIS ARMS TO HIS SIDES!

NO CROOK EVER HAD IT SO GOOD! LET'S BLAST HIM!

I MAY BE HAND-TIED--BUT I STILL HAVE THE USE OF MY LEGS!



Featuring... **GENIUS of the GETAWAY GIMMICKS!**



BATMAN



THEY ARE COMMITTING MISTAKES GETTING THE ENTRANCE GET RID OF BATMAN AND ROBIN-- BRINGING ON ME MY OWN DOOM!

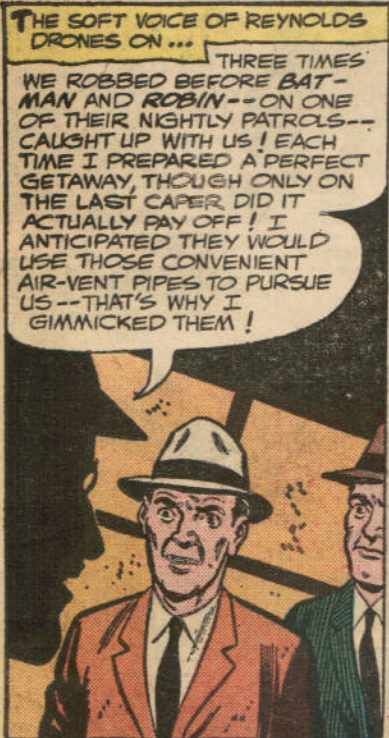

THE SOFT VOICE OF REYNOLDS DRONES ON... THREE TIMES WE ROBBED BEFORE BATMAN AND ROBIN-- ON ONE OF THEIR NIGHTLY PATROLS-- CAUGHT UP WITH US! EACH TIME I PREPARED A PERFECT GETAWAY, THOUGH ONLY ON THE LAST CAPER DID IT ACTUALLY PAY OFF! I ANTICIPATED THEY WOULD USE THOSE CONVENIENT AIR-VENT PIPES TO PURSUE US-- THAT'S WHY I GIMMICKED THEM!



FROM ALL OF THIS, THE MASTER CRIMINAL FORMULATES HIS FUNDAMENTAL PRINCIPLE... WHOEVER TRIES TO DOOM BATMAN-- DOOMS HIMSELF! ROB AND GETAWAY IS OUR RULE! FOLLOW IT TO THE LETTER!

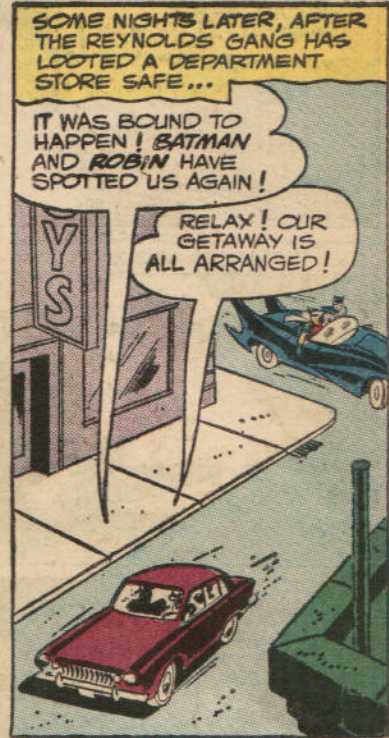

SOME NIGHTS LATER, AFTER THE REYNOLDS GANG HAS LOOTED A DEPARTMENT STORE SAFE...

IT WAS BOUND TO HAPPEN! BATMAN AND ROBIN HAVE SPOTTED US AGAIN!

RELAX! OUR GETAWAY IS ALL ARRANGED!



CHALLENGED

THEY WILL BE HAD NO PROOF OF ESCAPE EQUAL!

YOU'LL NEVER CAUSE ONLY OPEN THE WITH-ME! I'LL BE WITH YOU!

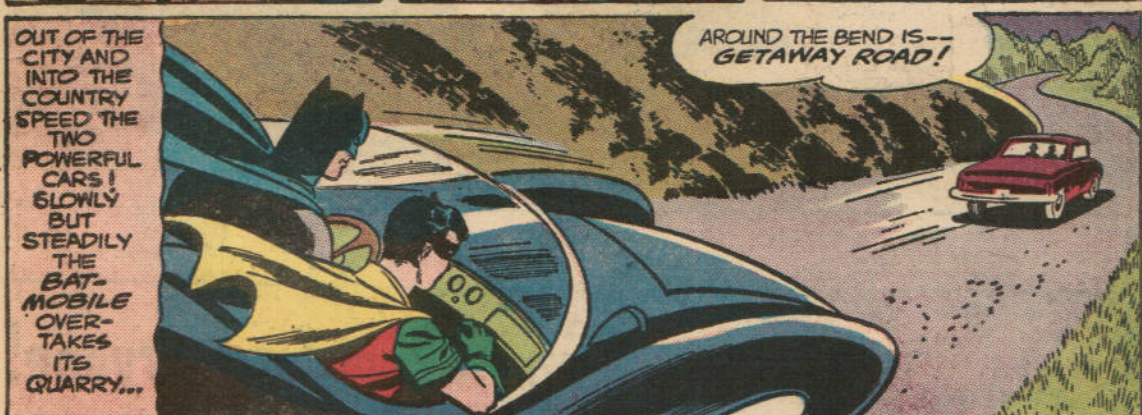

OUT OF THE CITY AND INTO THE COUNTRY SPEED THE TWO POWERFUL CARS! SLOWLY BUT STEADILY THE BAT-MOBILE OVERTAKES ITS QUARRY...

AROUND THE BEND IS-- GETAWAY ROAD!

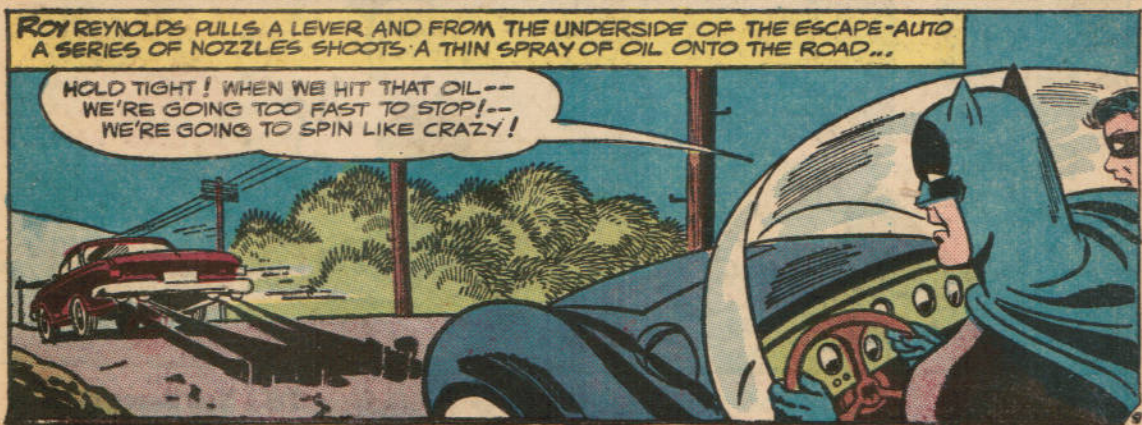

ROY REYNOLDS PULLS A LEVER AND FROM THE UNDERSIDE OF THE ESCAPE-AUTO A SERIES OF NOZZLES SHOOT A THIN SPRAY OF OIL ONTO THE ROAD...

HOLD TIGHT! WHEN WE HIT THAT OIL-- WE'RE GOING TOO FAST TO STOP!-- WE'RE GOING TO SPIN LIKE CRAZY!

AS S



"I
YOUR
M



"I'M
AN A
SAI

E. I. JOE IS AT YOU
Start with any of t
Get an action Soldie
Pilot complete with
tag and boots - the
realistic authenti

AS THE BATHOBILE
TIRES DRIVE ONTO
THAT SLICK SURFACE--
LIKE A COIN SPUN BY
A STRONG HAND--
THE CAR SPINS
AROUND...

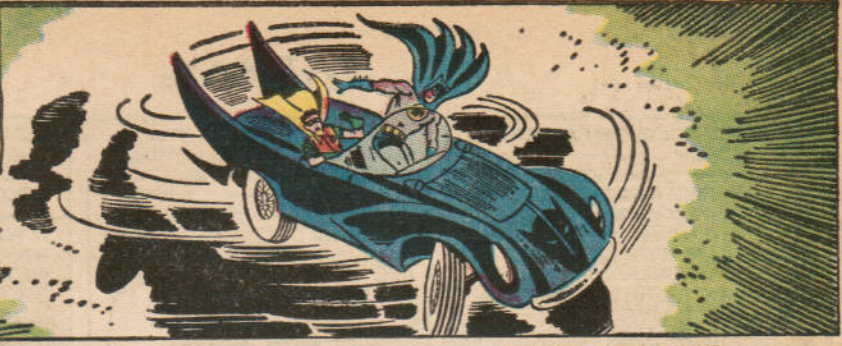

THE BOY WONDER IS FLUNG ONE WAY... THE COWLED CRUSADER THE OTHER...

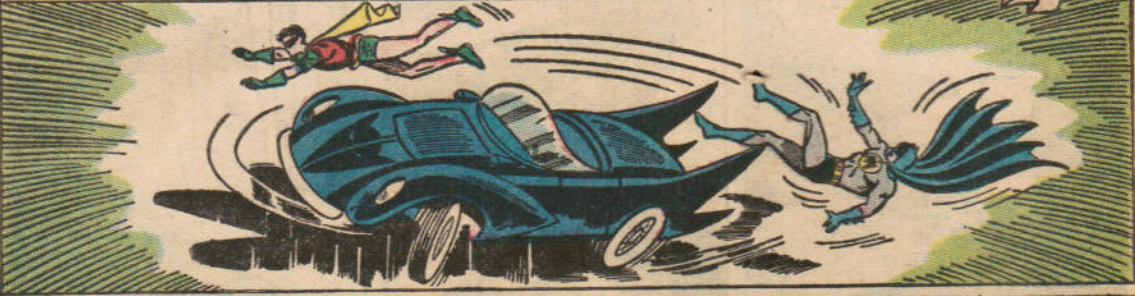

AND THE
BATHOBILE
WINDS UP
WITH A
CRUMPLED
FENDER
AGAINST
A
NEARBY
TELEPHONE
POLE...

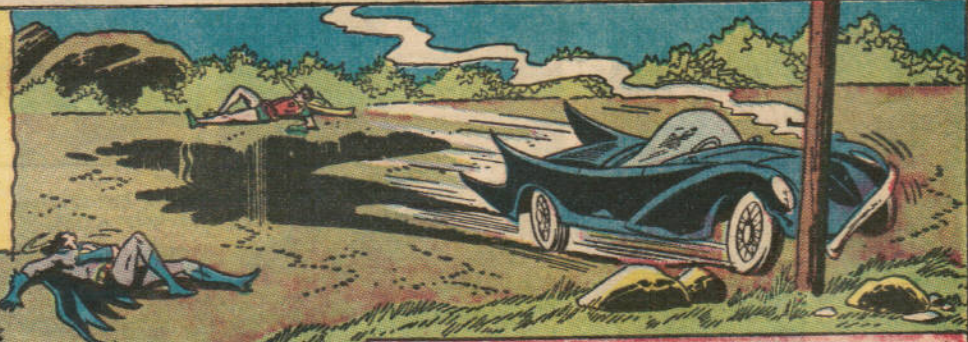

STORY CONTINUES ON 2ND PAGE FOLLOWING!

Silly Putty! ...indoor fun for everyone!

• ideal
for
party
favours!



- bounces!
- makes things!
- picks up comics!
- buy some where you bought this comic!

Silly Putty MARKETING P.O. Box 741 New Haven, Conn.



GENIUS OF THE GETAWAY GIMMICKS! PART 2

IN OIL-SMEARED UNIFORMS, THE MASKED MANHUNTER AND THE TEEN-AGE THUNDERBOLT STAGGER TOWARD THE BATMOBILE...

THEY GOT AWAY AGAIN... THANKS TO THOSE GETAWAY GIMMICKS!

THANKS TO US, TOO, ROBIN!

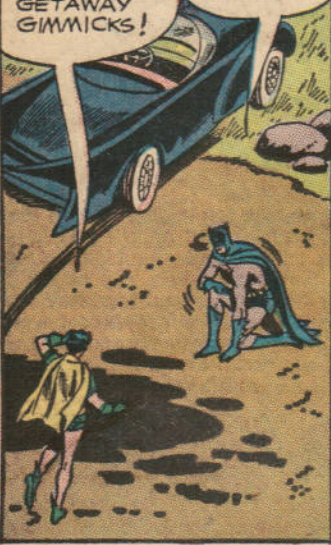

AMAZEMENT SHOWS ON THE FACE THE BOY WONDER TURNS TO HIS COMPANION...

THANKS... TO US?

YES! THEY'VE BEEN FOLLOWING A PREDETERMINED COURSE OF ACTION-- AND WE'VE BEEN BLUNDERING ALONG AFTER THEM!

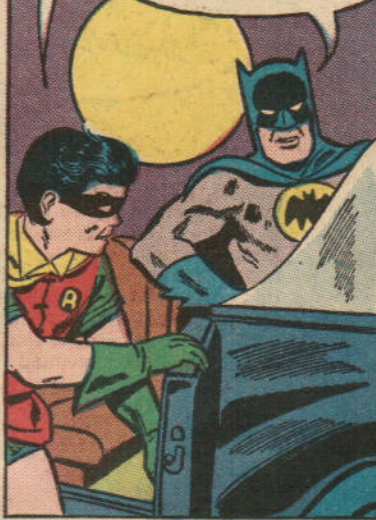

THE RINGLEADER WE'RE UP AGAINST DOESN'T BOTHER TO 'FINISH' US OFF THE WAY OTHER CROOKS DO! HIS ONLY CONCERN IS ELUDING US, SO HE PULLS GETAWAY STUNTS TO SHAKE US OFF HIS TRAIL!



THEY BEGIN THE LONG DRIVE HOMEWARD...



NEXT TIME HE ROBS AND WE SHOW UP, WE'LL PUT OURSELVES IN SUCH A HOPELESS POSITION--THOSE CROOKS WON'T BE ABLE TO RESIST TRYING TO GET RID OF US!

I CATCH ON! INSTEAD OF CONCENTRATING ON RUNNING AWAY--THEY'LL COME AFTER US!



EXACTLY! AND WHEN THEY DO-- SOCKO! WE'LL GET THEM!



SOME DAYS AFTER ROY REYNOLD'S NEWSPAPER'S HABIT...

HEL... THIS? BATMAN IN A TRAP BY A KNOW AS THE BUT GOT AWAY HIS MAN! AHA I'VE SAID RI



WIDE GRINS OF GREET THE ST THE HEXER..

IF THE HEXER OFF BATMAN IT'LL SAVE YOU TROUBLE! YOU WON'T HAVE TO THINK UP ANY MORE ESCAPE GIMMICKS!





BATMAN



A SIMPLE ACT, SUCH AS THE MAILING OF A LETTER, STARTS A STRANGE CHAIN OF EVENTS THAT WILL AFFECT MANY LIVES WEEKS LATER...

THERE IT GOES... ON ITS WAY TO THE CONTEST! IF THIS WORKS AS I PLANNED, THE OLD GAL IS DUE FOR A BIG SURPRISE!

WEEKS LATER, IN THE HOME OF WEALTHY BRUCE WAYNE AND HIS YOUNG WARD, DICK GRAYSON...

WHEN YOU TWO ARE FINISHED GORGING YOURSELVES, MAYBE YOU CAN TAKE A LITTLE TIME TO SOLVE A LITTLE MYSTERY FOR ME!

WHY WOULD AUNT HARRIET *ASK US TO LOOK IN ON A MYSTERY? IS IT POSSIBLE SHE SUSPECTS OUR SECRET IDENTITIES?

*EDITOR'S NOTE: AS REVEALED IN "GOTHAM GANG LINE-UP" IN THE JUNE, 1964 DETECTIVE COMICS, AUNT HARRIET IS THE AUNT OF DICK GRAYSON.

UHH... WHAT SORT OF MYSTERY?

ACTUALLY, IT CONCERNS MY FRIEND, MRS. TOMPKINS... THAT RETIRED OLD NURSE WHO LIVES NEARBY! SHE'S WON FIRST PRIZE IN A JINGLE CONTEST FOR A SOAP COMPANY...

...BUT WHAT ASTONISHED MRS. TOMPKINS IS THAT SHE NEVER ENTERED THE CONTEST! EVIDENTLY, SOMEONE ELSE SENT IN THE WINNING ENTRY. --- IN HER NAME!

NOW WHY WOULD ANYONE DO THAT? PERSONALLY, I THINK THERE'S SOMETHING SINISTER ABOUT THE WHOLE THING!

IT SHOULD BE LOOKED INTO ALL RIGHT-- AND AS SOON AS I FIND TIME, I'LL DO JUST THAT!

LATER, BRUCE AND DICK SECRETLY ENTER THEIR BATCAVE SANCTUM BENEATH THE WAYNE MANSION, WHERE...

I STILL CAN'T SHAKE THE FEELING THAT AUNT HARRIET KNOWS THAT WE'RE SECRETLY BATMAN AND ROBIN! SHE SEEMED TO INSINUATE SOMETHING IN HER REMARKS...

LET'S TACKLE ONE MYSTERY AT A TIME! MRS. TOMPKINS IS FIRST...



BATMAN



SHORTLY, AT THE MODEST HOME OF THE ELDERLY LADY...

A NEW CAR--REFRIGERATOR--STOVE--AND FREEZER--YET I DIDN'T EVEN ENTER THE CONTEST! I WISH I KNEW WHO ENTERED THAT CONTEST IN MY NAME--AND WHY!

Hmm! FIRST WE'LL CHECK WITH THE SOAP COMPANY...

THEN, AT THE OFFICES OF THE SOAP COMPANY...

THERE'S THE WINNING ENTRY AND THE ENVELOPE IT CAME IN!

BUT THIS ISN'T MRS. TOMPKINS' HANDWRITING! AND THE ENVELOPE ISN'T POSTMARKED GOTHAM CITY-- BUT HILLVALE!

TRUE--BUT THAT MADE NO DIFFERENCE TO US!

IT DOES TO ME! IT MEANS THAT WHOEVER MAILED THIS ENTRY IN MRS. TOMPKINS' NAME MAY LIVE IN HILLVALE--AND THAT'S WHERE WE'RE GOING NEXT!

THAT AFTERNOON, THERE IS AN EVENT THAT THE SMALL TOWN OF HILLVALE WILL NEVER FORGET!

YIPPEE! IT'S BATMAN AND ROBIN!

OH MY! THIS IS JUST ABOUT THE BIGGEST THING THAT EVER HAPPENED TO OUR TOWN!

HILLVALE IS A LONG WAY FROM GOTHAM CITY! I WONDER WHAT BRINGS BATMAN AND ROBIN HERE?

THE POLICE STATION--AND THE LOCAL POST OFFICE--SIDE BY SIDE! THAT MAKES IT CONVENIENT FOR US!

UH-OH! I BETTER TIP OFF THE BOSS ABOUT THIS... AND FAST!

SHORTLY, A FR SECRET GANG

STILTS-- WE C BATMAN AND BLEW INTO TO STRAIGHT FOR SHERIFF'S OF

PETE, YOU AND ON BATMAN. THE CHANC

LATER, ON THE CLIFF-SIDE ROAD LEADING OUT OF TOWN...

SUDDENLY, AT

YOU TOSS GRENADE ON TAR PETE



BATMAN



OFFICES OF THE
... BUT THIS
ISN'T MRS.
TOMPKINS'
HANDWRITING!
AND THE EN-
VELOPE ISN'T
POSTMARKED
GOTHAM CITY--
BUT HILL-
VALE!

IT THAT THE
NEVER FORGET!
ST ABOUT
IS THAT EVER
UR TOWN!

ER TIP OFF
UT THIS...
T!

SHORTLY, A FRANTIC MAN RUSHES INTO A
SECRET GANG HIDE-OUT...

STILTS-- WE GOT TROUBLE!
BATMAN AND ROBIN JUST
BLEW INTO TOWN--HEADED
STRAIGHT FOR THE
SHERIFF'S OFFICE!

WHA-AAT?!
THEY WOULDN'T
BE SNOOPING
AROUND HERE
UNLESS THEY
GOT A LEAD
SOMEHOW...

BUT HOW COULD BATMAN AND ROBIN
HAVE GOTTEN WISE TO US? I PLANNED
EVERYTHING SO
CAREFULLY!

PETE, YOU AND ED GO BACK AND KEEP TABS
ON BATMAN AND ROBIN! WHEN YOU GET
THE CHANCE, "HIT" BATMAN AND
ROBIN!

MEANWHILE, UPON BEING BRIEFED BY
BATMAN, THE SHERIFF CALLS IN THE
LOCAL POST OFFICE CLERK...

NOPE--DON'T RECOGNIZE THIS ENVELOPE!
WHOEVER MAILED IT, DIDN'T BRING IT TO ME
IN THE POST OFFICE DIRECT, BUT MUST'VE
DROPPED IT IN THE MAIL BOX OUTSIDE
AFTER CLOSING TIME!

LATER,
ON
THE
CLIFF-
SIDE
ROAD
LEADING
OUT OF
TOWN...

THE ENVELOPE HAS A DISTINCTIVE PATTERN IN THE PAPER!
THERE'S A STATIONERY STORE IN THE NEXT TOWN--SO IT'S
POSSIBLE THE SHOPKEEPER MIGHT CARRY SUCH A LINE
OF ENVELOPES AND REMEMBER TO WHOM IT WAS SOLD...

SUDDENLY, AT A TURN NEAR AN EXCAVATION SITE...

YOU TOSSED THAT
GRENADE RIGHT
ON TARGET,
PETE!

BOO-OOM!



BATMAN



THEN, NEAR DEMOLISHED RUINS OF WHAT WAS ONCE THE ANCHOR RESTAURANT...

NOW OUR GUNS WILL FINISH 'EM!

BATMAN AND ROBIN ARE TRICKY--SO LET'S MAKE SURE WE DON'T GOOF... BY SMASHING 'EM DOWN WITH THIS BULLDOZER!

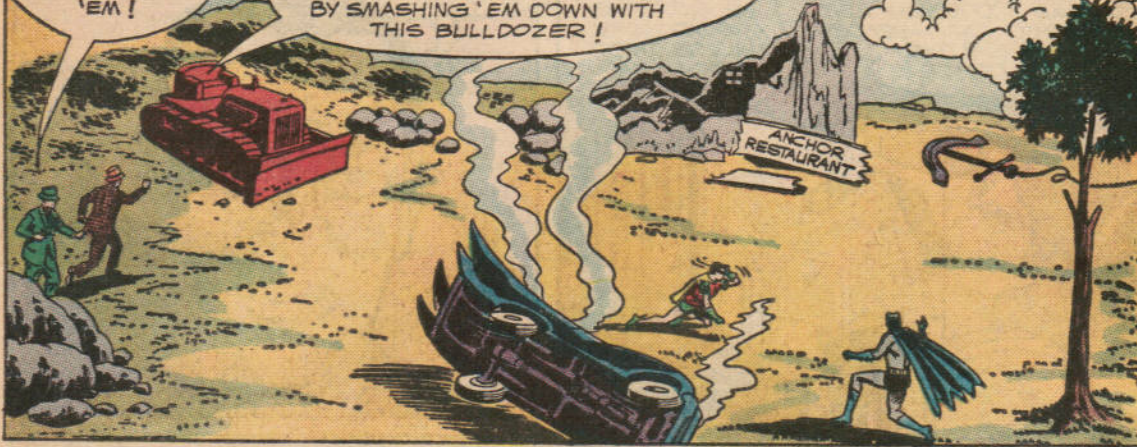

THE KID FIRST-- HE'S CLOSER!

IF THE BULLDOZER'S SHIELD EVER HITS ROBIN...

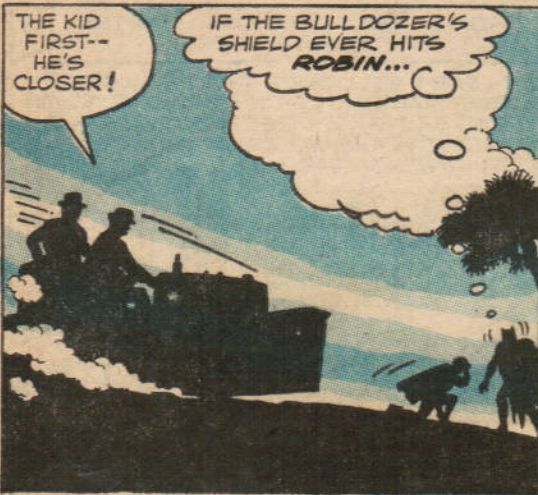

AS IF SHOT FROM A GUN, BATMAN SPEEDS FORWARD...

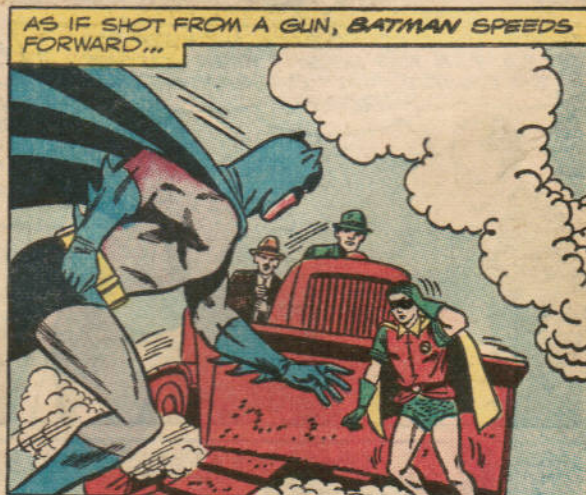

KRAK!

SLINGING ROBIN OVER HIS SHOULDER, BATMAN NOW BEGINS A RACE AGAINST DEATH AS HE DODGES THE RELENTLESS JUGGERNAUT!

HE'S DRIVING US BACK-- TOWARD THE EDGE OF THE CLIFF!

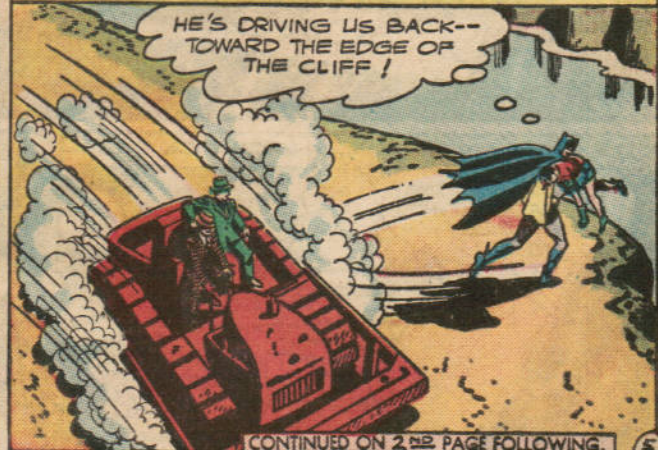
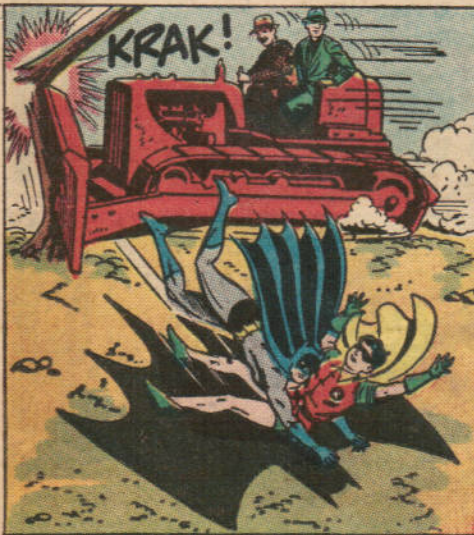

CONTINUED ON 2ND PAGE FOLLOWING.

ONLY \$1.98

ASTROFORCE

SPACE SOLDIERS of the FUTURE

TOGETHER WITH FIGHTING ACCESSORIES

EVERYONE WILL WANT TO OWN THIS SUPERB AND UNUSUAL COLLECTION OF ASTROFORCE SPACE SOLDIERS OF THE FUTURE TOGETHER WITH FULL BATTLE EQUIPMENT. NOW--YOU, TOO--CAN PLAN AND FIGHT INTERPLANETARY GALACTIC BATTLES IN THE WAR OF THE WORLDS--BAT--CAN YOU?

16¢



Extra! A NEW ELONGATED MAN STORY!

BY THE COMICS CODE AUTHORITY

12¢

MAR. NO. 337

DETECTIVE COMICS

Featuring "The DEEP-FREEZE MENACE!"

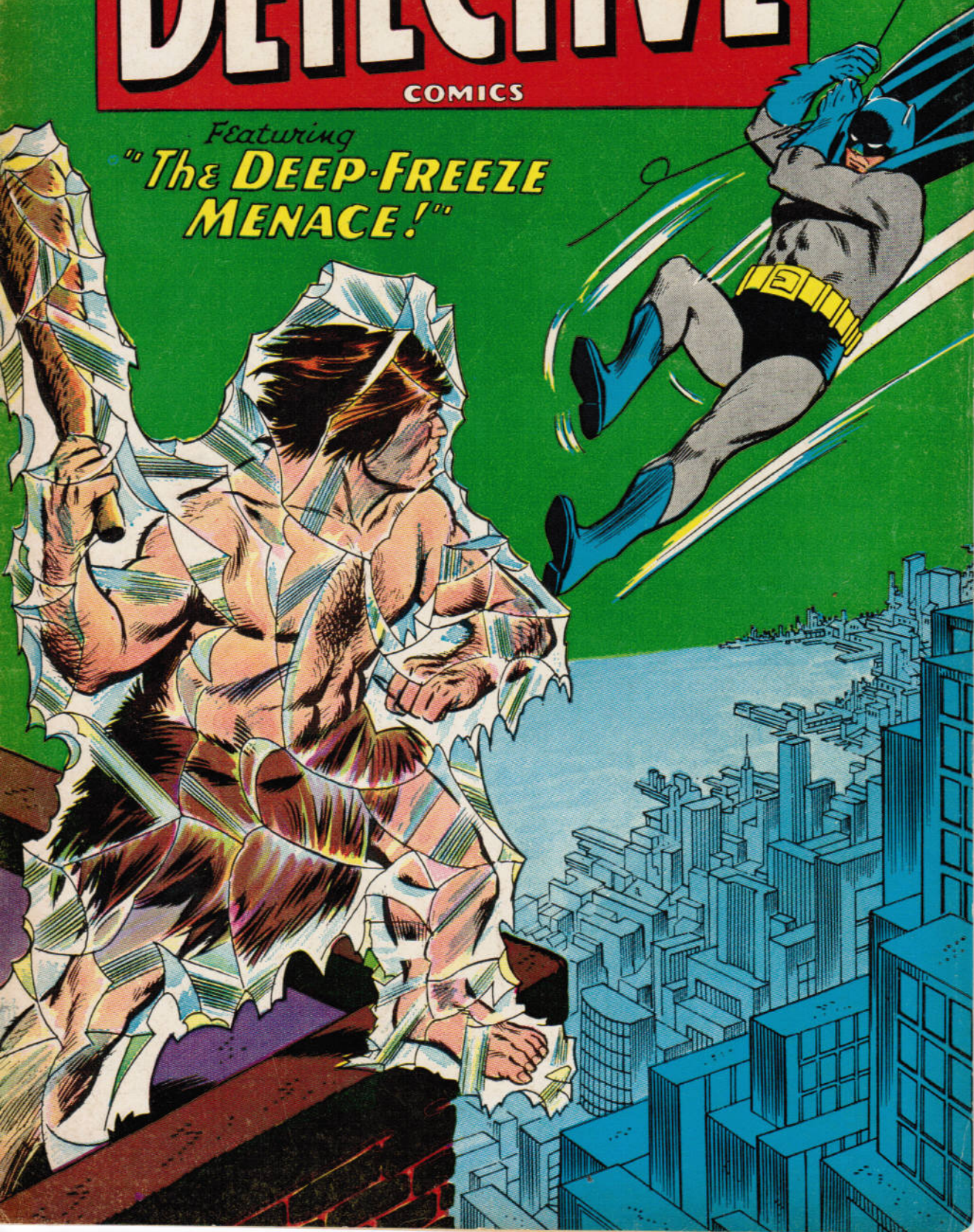



DETECTIVE COMICS



Chapter 2

KLAG BRINGS HIS CLUB DOWNWARD. WITH HIS LAST FADING STRENGTH, BATMAN LEAPS SIDWAYS BUT NOT QUITE FAST ENOUGH TO AVOID THAT AWESOME BLOW...

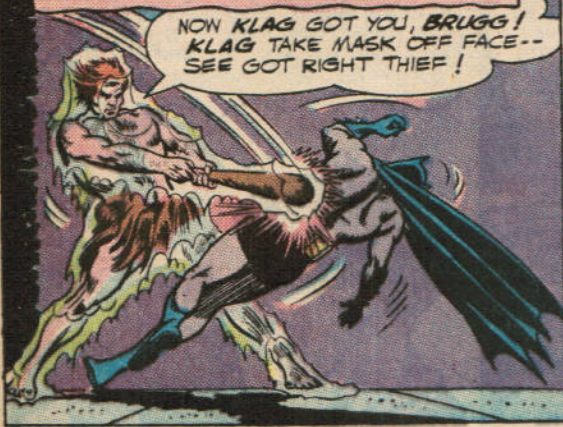

NOW KLAG GOT YOU, BRUGG! KLAG TAKE MASK OFF FACE-- SEE GOT RIGHT THIEF!

AS HE RIPS AWAY THE MASK, KLAG STANDS FROZEN IN DISMAY! HE WAS SO SURE, THIS TIME! BUT THIS TOO IS NOT BRUGG! HIS HUNTER'S SENSE OF SMELL TELLS HIM SO...



WHERE BRUGG? KLAG FIND HIM NEXT TIME... FOR SURE!



HIMSELF STILL DAZED, THE BOY WONDER CRAWLS TOWARD HIS MENTOR, EVEN AS KLAG BEGINS TO LEVITATE UPWARD.

GOT TO REACH BATMAN-- PUT HIS MASK BACK ON BEFORE ANYONE SEES HIS FACE!

KLAG SEE OTHER BRUGG-- ACROSS BIG WATER! KLAG GO!

HIS MASK REPLACED, THE COWLED CRUSADER IS ASSISTED TO HIS FEET BY WILLING HANDS...

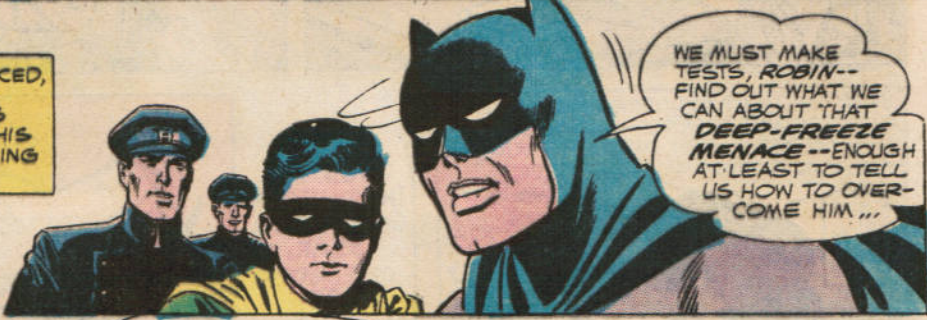

WE MUST MAKE TESTS, ROBIN-- FIND OUT WHAT WE CAN ABOUT THAT DEEP-FREEZE MENACE-- ENOUGH AT LEAST TO TELL US HOW TO OVER-COME HIM...

FOR THE NEXT SEVERAL MINUTES, THE DETECTIVE DUO IS BUSY PICKING UP ALL TRACES OF THEIR ENCOUNTER...



WE'LL DO A BETTER JOB IN THE BATCAVE-- SO GATHER EVERY LITTLE CLUE YOU CAN, ROBIN!

SOME OF THAT ICE-COATING HE WEARS DRIPPED OFF INTO THIS DIRT I'M COLLECTING!

CONTINUED ON 2ND PAGE FOLLOWING.

United States Patent Office

Dec. 215,333
 Printed Oct. 19, 1944

281,779
 AUTOMOTIVE TRUCKLE OR WHEEL ASSEMBLY

George Davis, 1818 Holly Drive, Eads, Miss.

Filed Mar. 11, 1944, Ser. No. 1,417

Term of patent 14 years

Cl. 281-109

Dec. 20, 1944
 281,779

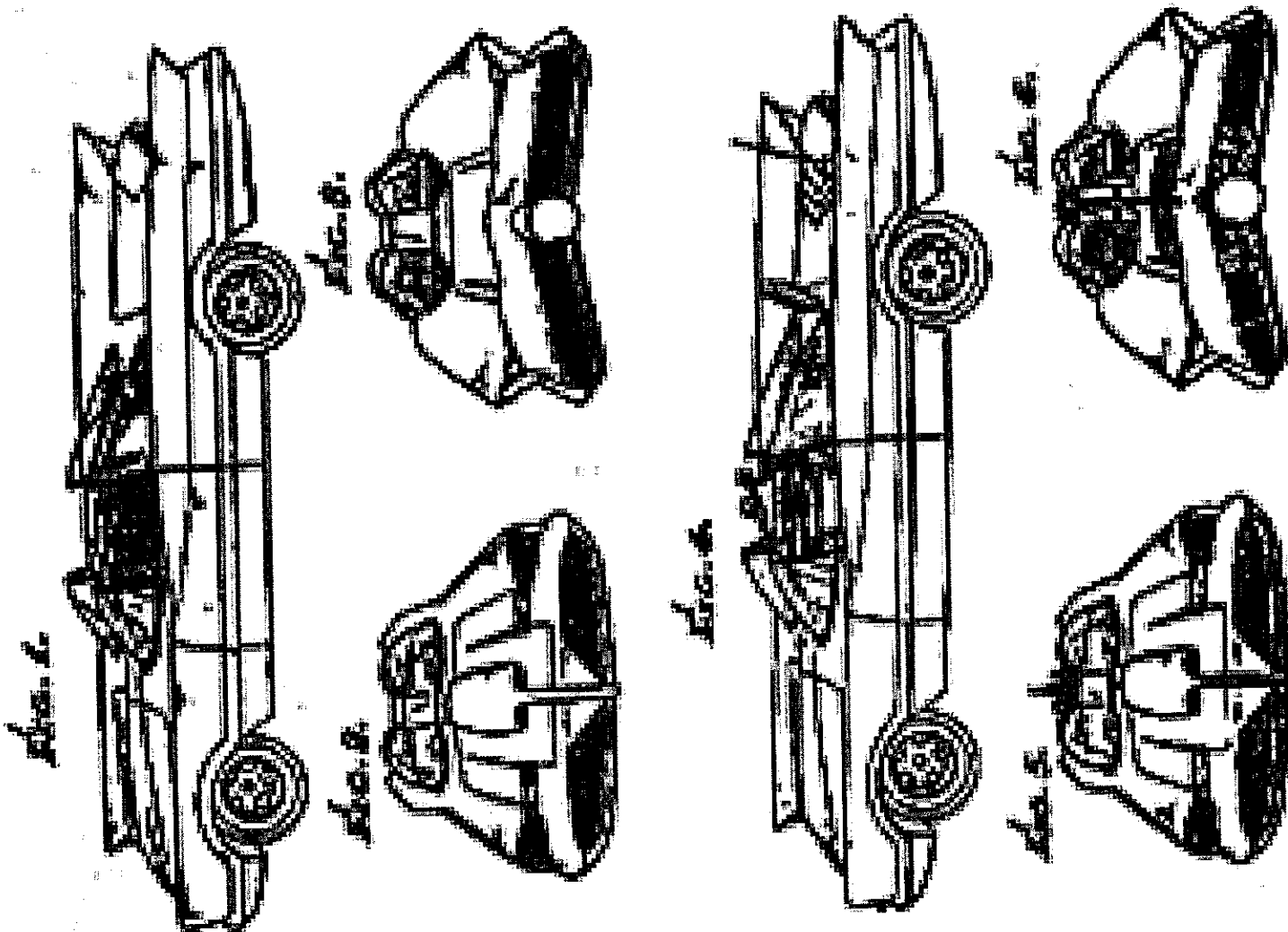

FIGURE 1 is a side perspective view of an automotive truckle or wheel assembly showing my new design.
FIGURE 2 is a cross perspective view of an automotive truckle or wheel assembly showing my new design.
FIGURE 3 is a side perspective view of an automotive truckle or wheel assembly showing my new design.
FIGURE 4 is a cross perspective view showing a partial disengagement of my new design.
FIGURE 5 is a side perspective view of the complete new truckle or wheel assembly shown in **FIGURE 1**, and
FIGURE 6 is a cross perspective view of the automotive

FIGURE 1
 The conventional design for an automotive truckle or wheel assembly, as shown and described.

Reference Made by the Examiner
 UNITED STATES PATENTS
 G. H. JAMES, JR., Commissioner
 WALLACE H. BLAIR, Primary Examiner
 GEORGE A. BOUSQUET, Assistant Examiner

[54] CAR OR SIMILAR ARTICLE

[75] Inventor: Anton Furst, London, England

[73] Assignee: DC Comics Inc., New York, N.Y.

[**] Term: 14 Years

[21] Appl. No.: 345,559

[22] Filed: Apr. 28, 1989

[30] Foreign Application Priority Data

Jan. 26, 1989 [GB] United Kingdom 1056632

Jan. 26, 1989 [GB] United Kingdom 1056633

[52] U.S. Cl. D12/92; D21/137

[58] Field of Search D21/59, 124, 128, 132, D21/133, 134, 135, 136, 137, 140; D12/13, 82, 85, 86, 88, 90, 91, 92, 112; 446/85, 88, 93, 94, 95, 432, 440, 450, 451, 465, 466, 468, 470, 487

[56] References Cited

U.S. PATENT DOCUMENTS

- D. 176,255 12/1955 Handler D12/92
- D. 203,841 2/1966 Power D21/136
- D. 206,062 10/1966 Mitchell D12/91
- D. 206,063 10/1966 Mitchell D12/91
- D. 218,695 9/1970 Broadley D12/92

- D. 243,595 3/1977 Belz D12/91
- D. 250,908 1/1979 Appel D21/136
- D. 278,043 3/1985 Avery D12/92
- D. 279,591 7/1985 Ogawa D21/132
- D. 280,223 8/1985 Barbato et al. D21/136
- D. 282,676 2/1986 Effler et al. D21/128
- D. 283,717 5/1986 Obara D21/136
- D. 293,258 12/1987 Noshiro D21/136
- D. 301,355 5/1989 Doi D21/136

Primary Examiner—Charles A. Rademaker
Assistant Examiner—Alicia A. Farrell
Attorney, Agent, or Firm—Notaro & Michalos

[57] CLAIM

The ornamental design for a car or similar article, as shown and described.

DESCRIPTION

FIG. 1 is a front perspective view of a vehicle showing my new design;
FIG. 2 is a rear perspective view thereof;
FIG. 3 is a front elevational view thereof;
FIG. 4 is a rear elevational view thereof;
FIG. 5 is a side elevational view thereof; and
FIG. 6 is a top plan view thereof.
The unshown bottom of the design is substantially plain and unornamented.

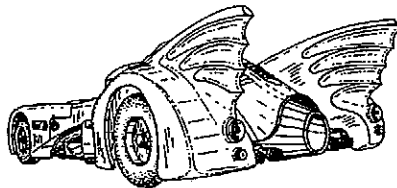
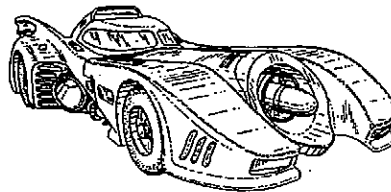

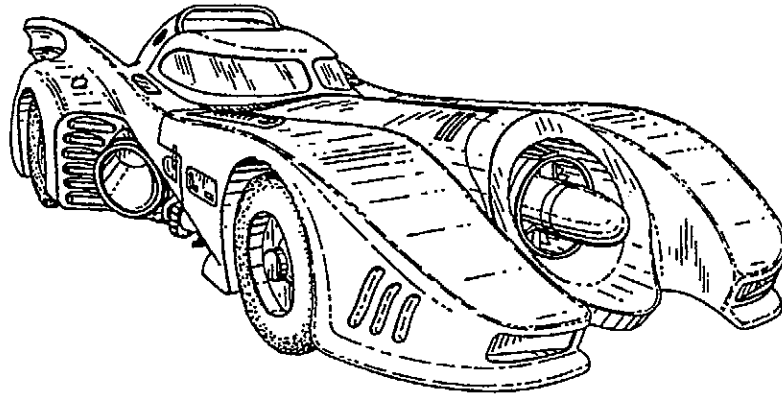

FIG. 1

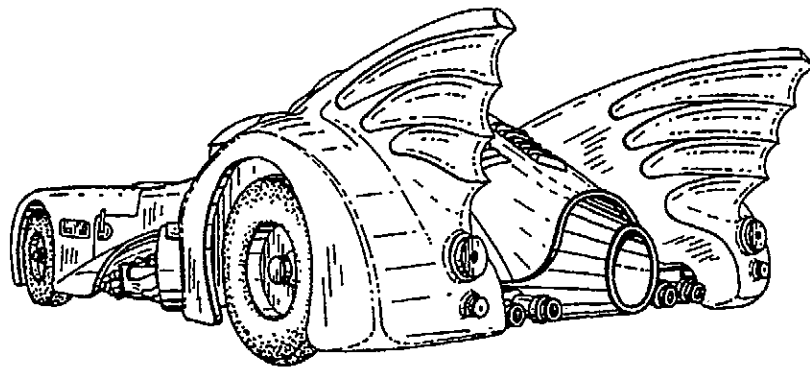

FIG. 2

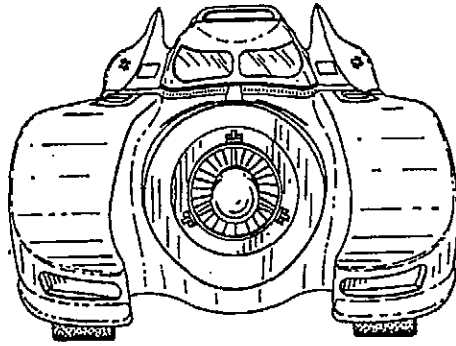

FIG. 3

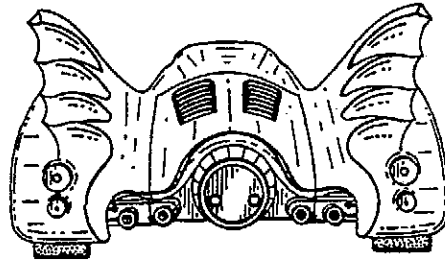

FIG. 4

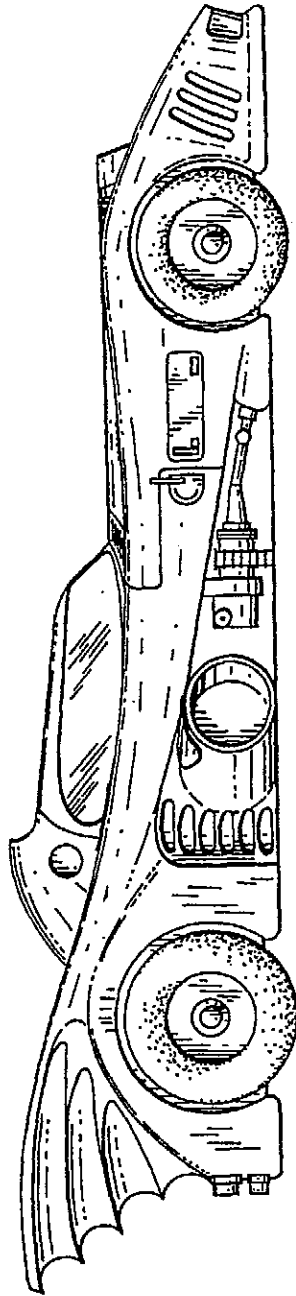

FIG. 5

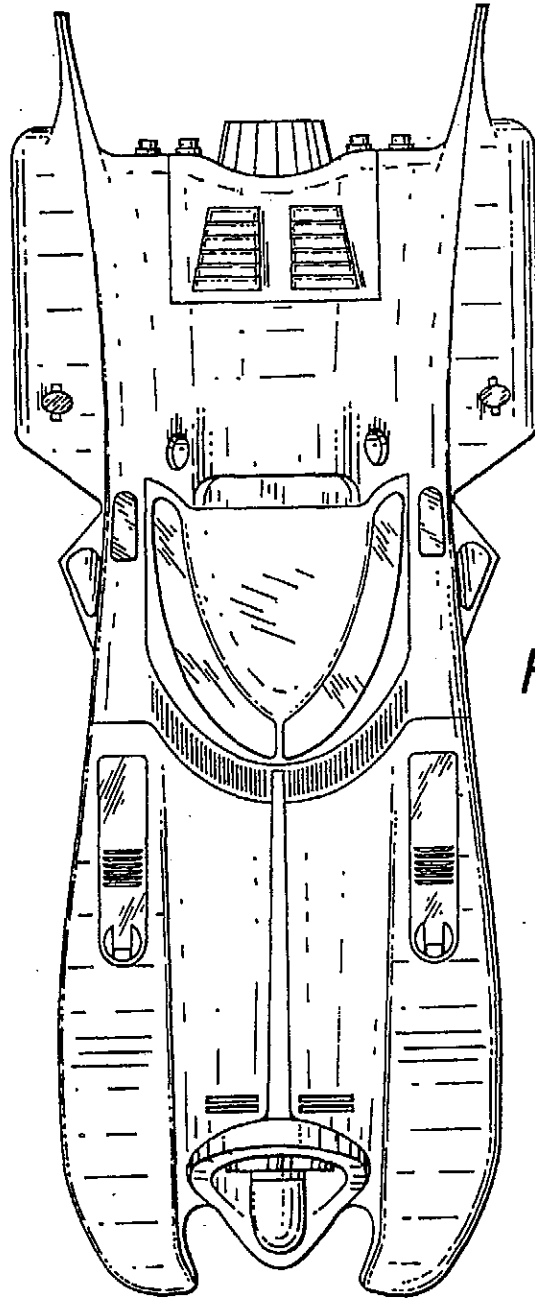

FIG. 6

United States Patent [19]

Flattery et al.

[11] **Patent Number:** **Des. 375,704**

[45] **Date of Patent:** ****Nov. 19, 1996**

[54] **VEHICLE**

[75] **Inventors:** **Tim Flattery, Newbury Park; Barbara Ling, Echo Park; Joel Schumacher, Burbank, all of Calif.**

[73] **Assignee:** **DC Comics, New York, N.Y.**

[**] **Term:** **14 Years**

[21] **Appl. No.:** **47,605**

[22] **Filed:** **Dec. 8, 1995**

Related U.S. Application Data

[63] **Continuation of Ser. No. 39,258, Jun. 1, 1995, abandoned.**

[52] **U.S. Cl. D12/86**

[58] **Field of Search D12/1, 91, 92, D12/181; 296/185, 180.1, 180.3; D21/128, 136, 137**

[56] **References Cited**

U.S. PATENT DOCUMENTS

D. 80,844	4/1930	Loewy	D12/90
D. 83,083	1/1931	Wenning	D12/91
D. 86,742	4/1932	Pike	D12/91
D. 93,995	12/1934	Northrup	D12/91
D. 97,697	12/1935	Buehrig	D12/86
D. 152,320	1/1949	Buehrig	D12/88
D. 169,448	4/1953	Lane	D12/91
D. 176,255	12/1955	Handler	D34/15
D. 180,509	6/1957	Earl	D12/92
D. 182,368	3/1958	Luntz	D14/3
D. 184,921	4/1959	Eggers	D14/3
D. 185,843	8/1959	James	D14/3
D. 187,021	1/1960	Marinelli	D14/3
D. 203,841	2/1966	Power	D34/15
D. 205,764	9/1966	Brisendine	D14/3
D. 205,998	10/1966	Barris	D14/3
D. 248,886	8/1978	Kato	D34/15
D. 293,002	12/1987	Ohkawa	D21/87

D. 293,258	12/1987	Noshiro	D21/136
D. 311,882	11/1990	Furst	D12/92
D. 331,895	12/1992	Panoz et al.	D12/92
D. 337,626	7/1993	Chen	D21/136
1,266,191	5/1918	Adsit	296/180.1
3,298,707	1/1967	Gerin	280/87
4,925,236	5/1990	Itoh et al.	296/180.5
5,374,098	12/1994	Nelson	296/180.1

Primary Examiner—Freda Nunn
Attorney, Agent, or Firm—Notaro & Michalos P.C.

[57] **CLAIM**

The ornamental design for a vehicle, as shown and described.

DESCRIPTION

FIG. 1 is a front perspective view of the vehicle of the invention, as viewed from the top, left-hand side with the rear fins closed;
 FIG. 2 is a front view of the vehicle of the invention, with the rear fins closed;
 FIG. 3 is a side view of the vehicle of the invention with the rear fins closed;
 FIG. 4 is a top plan view of the vehicle of the invention with the rear fins closed;
 FIG. 5 is a rear view of the vehicle of the invention with the rear fins closed;
 FIG. 6 is a front perspective view of the vehicle of the invention, as viewed from the top, left-hand side, with the rear fins open;
 FIG. 7 is a front view of the vehicle of the invention, with the rear fins open;
 FIG. 8 is a side view of the vehicle of the invention, with the rear fins open;
 FIG. 9 is a top plan view of the vehicle of the invention, with the rear fins open; and,
 FIG. 10 is a rear view of the vehicle of the invention, with the rear fins open.

1 Claim, 4 Drawing Sheets

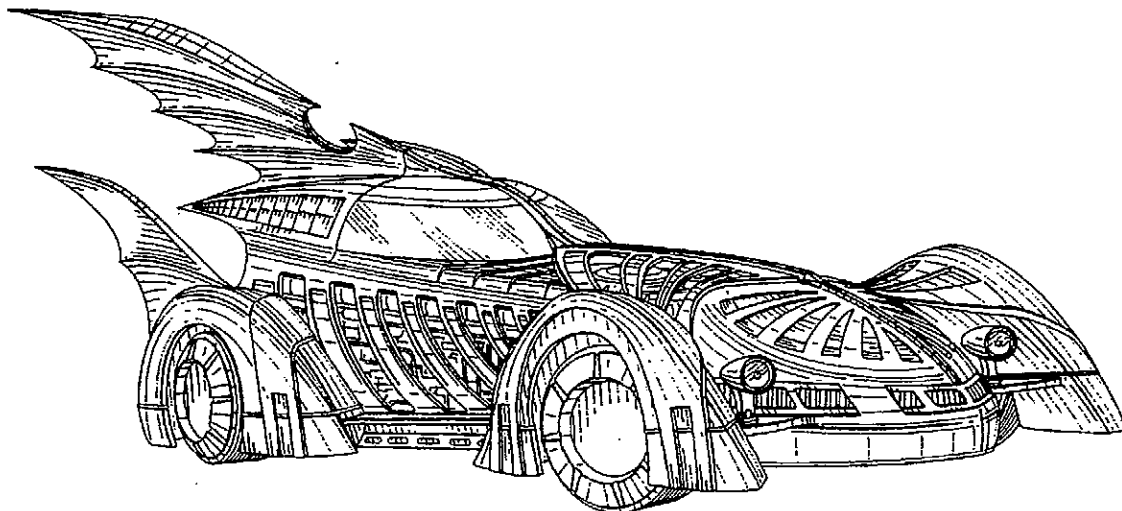

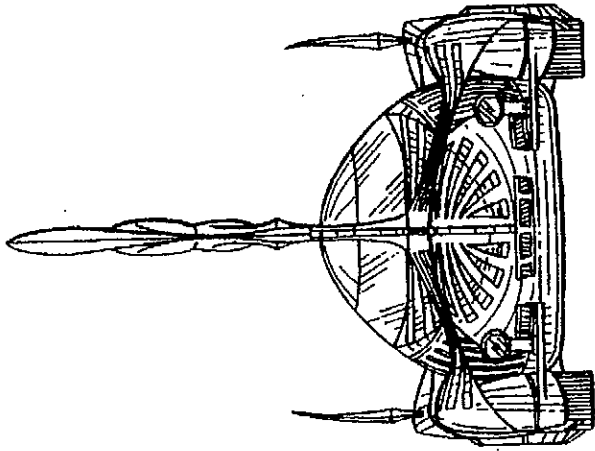
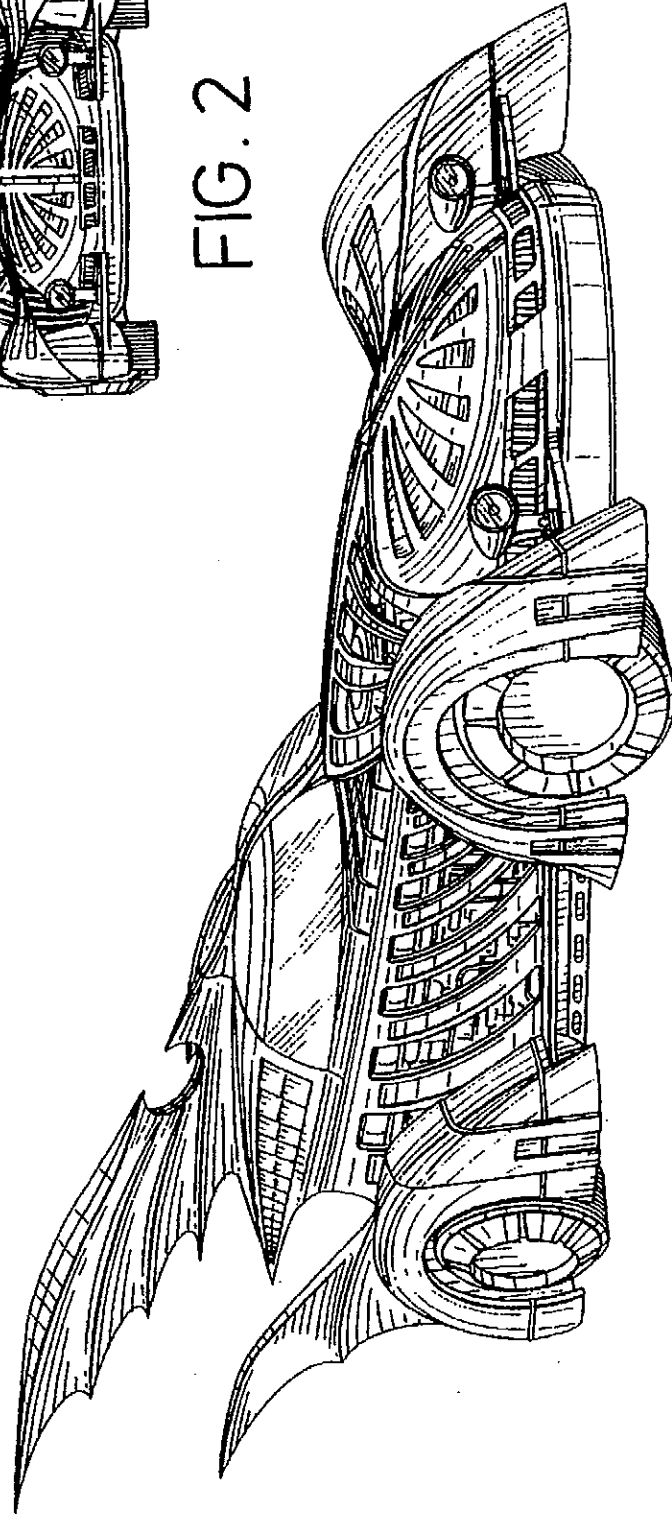

FIG. 1

FIG. 2



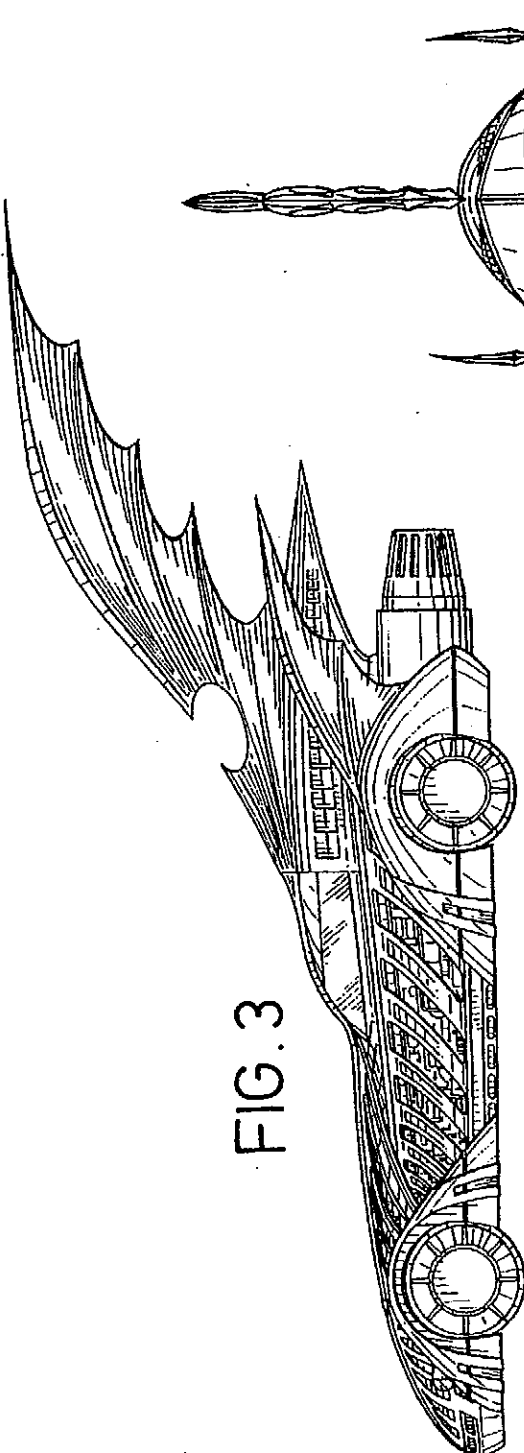

FIG. 3

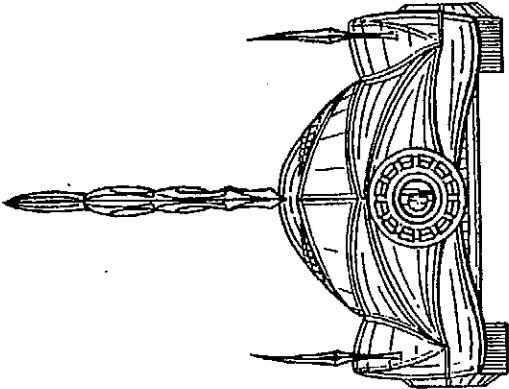

FIG. 5

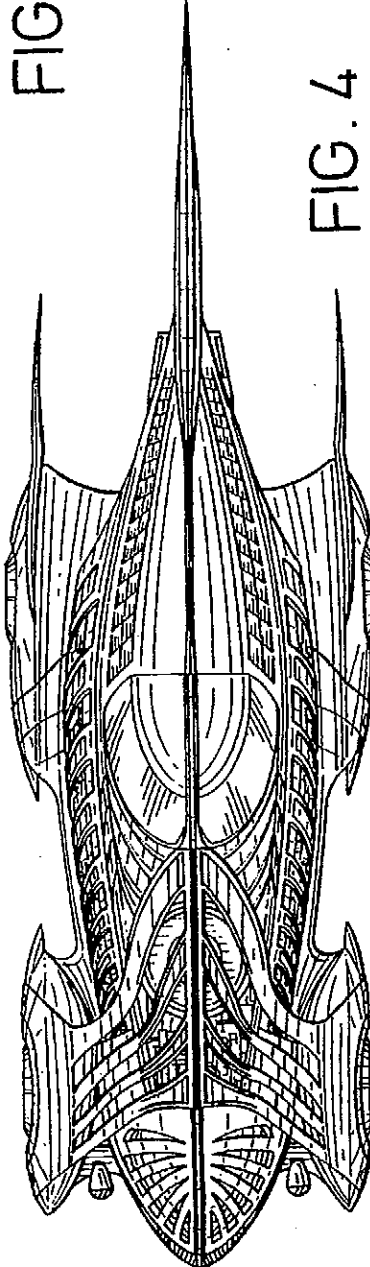

FIG. 4

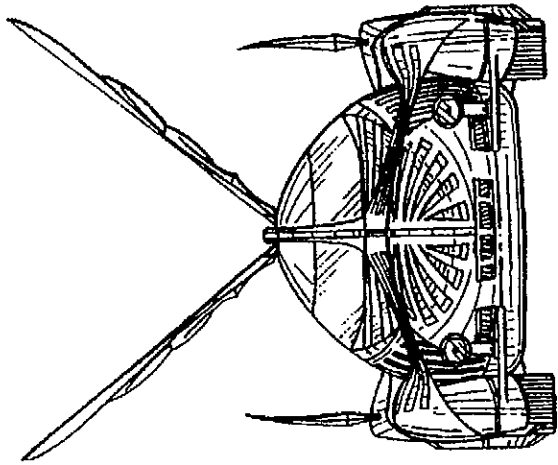

FIG. 6

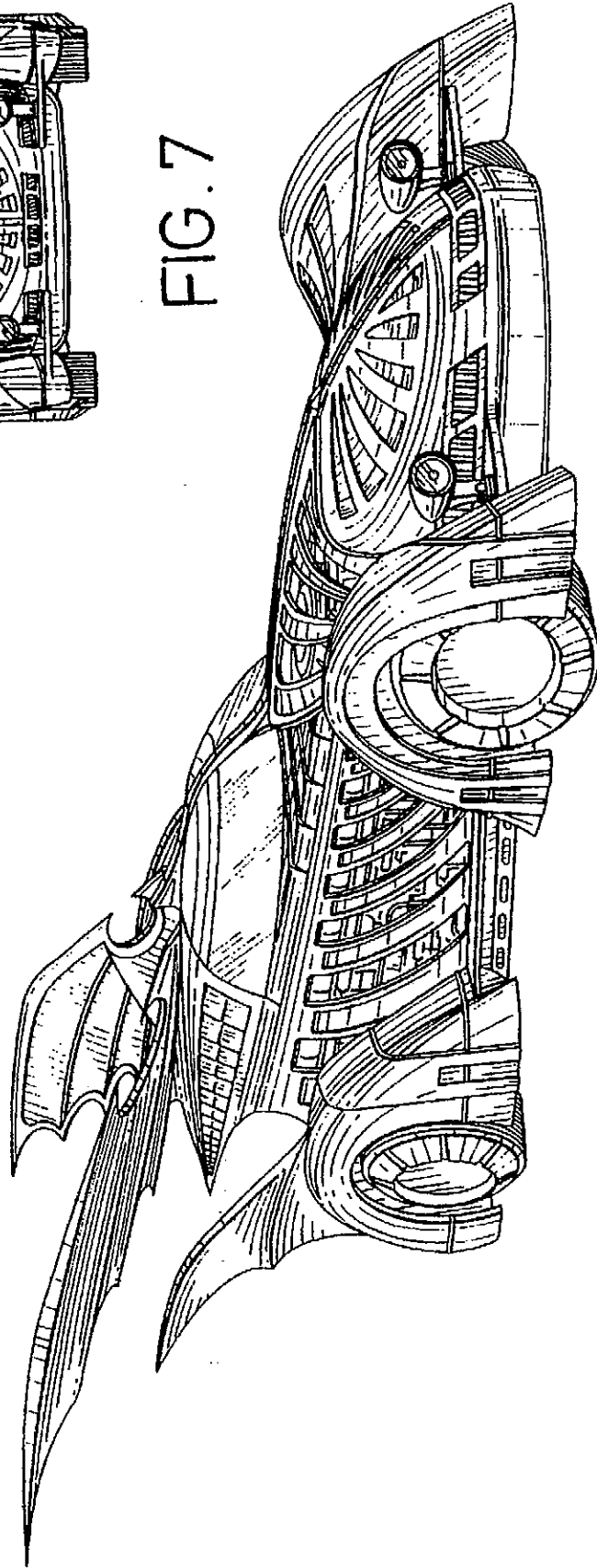

FIG. 7

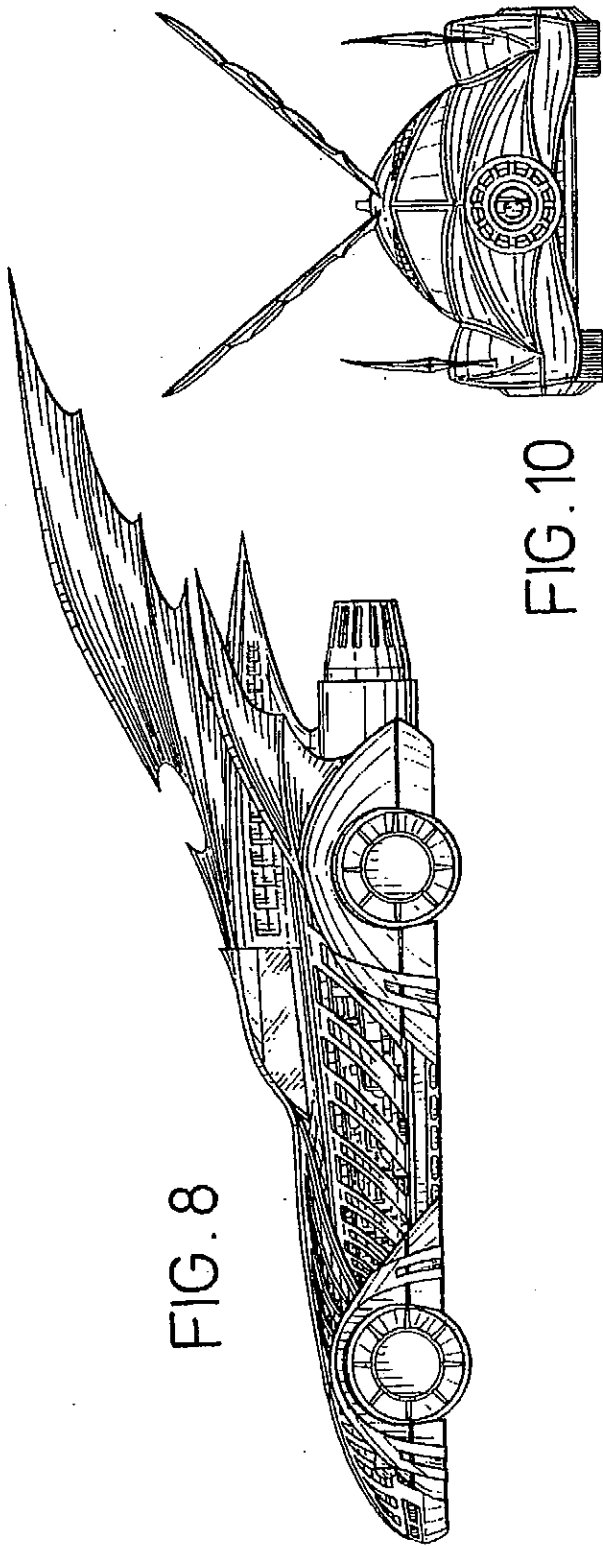

FIG. 8

FIG. 10

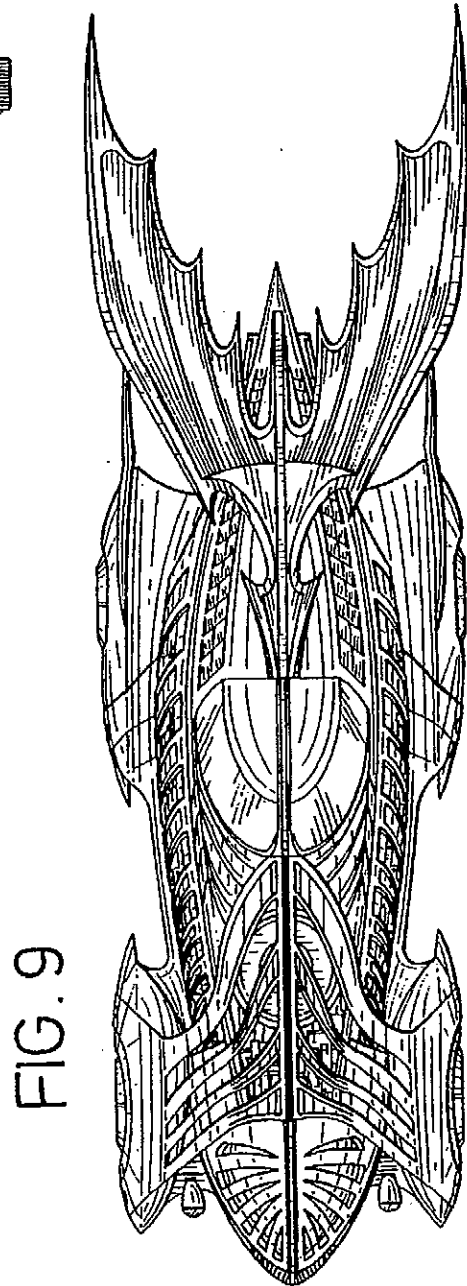

FIG. 9