

Exhibit Q

WC 02-361

Before the
FEDERAL COMMUNICATIONS COMMISSION
Washington, D.C. 20554

RECEIVED

OCT 18 2002

FEDERAL COMMUNICATIONS COMMISSION
OFFICE OF THE SECRETARY

In the Matter of)
)
Petition for Declaratory Ruling that AT&T's)
Phone-to-Phone IP Telephony Services Are)
Exempt from Access Charges)

PETITION FOR DECLARATORY RULING THAT AT&T'S PHONE-TO-PHONE
IP TELEPHONY SERVICES ARE EXEMPT FROM ACCESS CHARGES

David W. Carpenter
Sidley Austin Brown & Wood
Bank One Plaza
10 S. Dearborn
Chicago, Illinois 60603
(312) 853-7237

Mark C. Rosenblum
Lawrence J. Lafaro
Judy Sello
AT&T Corp.
Room 3A229
900 Route 202/206 North
Bedminster, New Jersey 07921
(908) 532-1846

David L. Lawson
Julie M. Zampa
Sidley Austin Brown & Wood LLP
1501 K Street, N.W.
Washington, D.C. 20005
(202) 7368000

October 18, 2002 ...

COPY

TABLE OF CONTEXTS

	<u>PAGE</u>
INTRODUCTION AND SUMMARY	1
BACKGROUND	0
1. ISP Exemption	7
2. The Internet And VOIP Telephony	8
3. Tlic 1998 Universal Service Report	12
4. The U S West Petition And The Subsequent Developments	15
5. AT&T's VOIP Services	17
6. The Controversy Over Interstate Access Charges	19
7. State Decisions and Controversies	21
ARGUMENT.....	22
I. BECAUSE AT&T'S PHONE-TO-PIHONE IP AND OTHER SERVICES ARE PROVIDED OVER THE INTERNET. THEY MUST BE EXEMPT FROM REQUIREMENTS THAT THEY PURCHASE ACCESS SERVICES THAT ARE ABOVE-COST AND INEFFICIENT.....	24
II. THE ILECS' ACCESS CHARGE ASSESSMENTS VIOLATE THE COMMISSION'S POLICY OF EXEMPTING PHONE-TO-PHONE IP TELEPHONY SERVICES FROM ACCESS CHARGES PENDING FUTURE COMMISSION ACTION	25
CONCLUSION	33

Before the
FEDERAL COMMUNICATIONS COMMISSION
Washington, D C. 20554

In the Marter of)
)
Petition for Declaratory Ruling that AT&T's
Phone-to-Phone IP Telcphony Services Are)
Exempt from Access Charges)

**PETITION FOR DECLARATORY RULING THAT AT&T'S PHONE-TO-PHONE
IP TELEPHONY SERVICES ARE EXEMPT FROM ACCESS CHARGES**

AT&T Corp. ("AT&T") respectfully petitions the Commission for a declaratory ruling that the "phone-to-phone" IP telephony services that AT&T offers over the Internet are exempt from the access charges applicable to circuit switched interexchange calls and are lawfully being provided over end user local services. AT&T seeks this relief to resolve actual controversies with LECs over the applicability of interstate access charges to AT&T services and to provide guidance to states who follow the federal rule in assessing intrastate access charges.

INTRODUCTION AND SUMMARY

AT&T seeks a declaratory ruling that incumbent local exchange carriers ("ILECs") are **unlawfully** imposing access charges on the nascent "phone-to-phone" Internet Protocol ("IP") telephony service that AT&T and others are providing over the Internet. AT&T's provision of these services required it to make large investments in "common" Internet backbone facilities that carry all types of Internet traffic, and AT&T's investments and very limited initial voice offerings are essential preconditions to future offerings of the integrated voice, data, and multimedia services that IP allows. AT&T submits that the ILECs' efforts to

impose access charges on this phone-to-phone Internet traffic violates: (1) the congressional mandate to “preserve the vibrant and competitive free market that presently exists for the Internet” and (2) the Commission’s established policy of exempting all voice over Internet Protocol (“VOIP”) services from access charges pending the future adoption of nondiscriminatory regulations on this subject.

Foremost, the Commission has long recognized that it would subvert the congressional policy of fostering the Internet if nascent and emerging Internet services were required to pay the access charges that are currently applicable to circuit switched interexchange services. It has found that access charge rate structures are “above cost” and “inefficient” and that it would distort and disrupt Internet services and investments that are “still evolving” if the services were subject to these inflated charges, rather than to rates that apply to end user or other local services and that can fully compensate LECs for all legitimate costs. These are the reasons that the Commission has exempted all enhanced and information service providers (collectively referred to as “ISPs”) from the requirement that they pay access charges and has permitted them to subscribe instead to end user local services.

For the same reasons, the Commission has treated all the nascent and emerging VOIP telephone services as enjoying the ISP exemption until such time as the industry matures, a full record is compiled, and the Commission determines whether some form of access charges can properly, feasibly, and nondiscriminatorily be applied to some forms of these services. In particular, the Commission has repeatedly refused the ILECs’ entreaties that the Commission hold that phone-to-phone or other VOIP services are required to order originating and terminating access services and to pay the same access charges applicable to circuit switched interexchange calls.

The first such action was the Commission's 1998 *Universal Service Report* to Congress. The Commission there tentatively concluded that certain configurations of VOIP services (computer-to-computer and computer-to-voice) are information services and that other configurations (phone-to-phone) are telecommunications services, regardless of whether the services are provided over the common Internet (like AT&T's service) or over interexchange networks that use Internet Protocol. But the Commission stated that the nascent services would have to mature and a complete record would have to be compiled before it could determine if these tentative classifications were rational and sustainable, and the Commission deferred these issues to future proceedings.

Most fundamentally, the Commission stated that even if it thereafter found that all phone-to-phone IP telephony services are telecommunications services that placed the "same burdens" on the local exchange as do circuit switched interexchange calls, it would not follow that the IP services would be subject to the *same* access charges that are applicable to circuit switched long distance services. Quite the contrary, the Commission stated only that it "*may*" then "find it reasonable" to require "certain forms" of "phone-to-phone IP telephony services" to pay "*similar* access charges" and that the adoption of such a requirement would raise "difficult and contested issues:" *e.g.*, whether there was an "adequate" and technologically sustainable basis for "distinction" between phone-to-phone and other VOIP services and whether the determinations required to assess per minute charges on all phone-to-voice services could reliably be made. Three individual commissioners contemporaneously made statements that either opposed, or expressed grave reservation about, subjecting VOIP and other innovative IP services to these and other regulations applicable to circuit switched long distance service.

The following year the Commission thus refused even to entertain U S West's April 1999 petition for a declaratory ruling that *access* charges apply to phone-to-photoc IP telephony services that are not offered over the Internet, but use IP in the internal interexchange networks. U S West had contended that these latter services are subject to access charges as a matter of law because they are "telecommunications services," and not information services. But this was the same legal theory that the Commission had rejected in the *Universal Service Report*, and the Commission did not even issue a Public Notice or otherwise request comment on the U S West petition. In the ensuing years, the Commission has not elsewhere addressed the applicability of access charges to phone-to-photoc IP telephony services.

By declining to require providers of phone-to-photoc IP telephony services to order inflated access service, the Commission allowed them to use end user local services that are priced closer to their economic cost. This has been the uniform practice of the many firms that are providing nascent wholesale and retail phone-to-photoc IP telephony services – which collectively represent a tiny fraction (1%-5%) of interexchange calling. For example, while AT&T has elected to use access services to originate its calls, AT&T has terminated its phone-to-photoc IP telephony services over the same local facilities and services that terminate its ISP traffic: principally, private lines obtained from CLECs and ILECs, with the CLECs terminating calls on reciprocal compensation trunks if the called party is an TLEC customer.

However, after failing to obtain Commission rulings that providers of phone-to-photoc IP telephony services are required to use access services, incumbent LECs are now attempting to effect end runs around the Commission's policy by engaging in self-help. Because they are taking the position that the business lines and other local facilities are available only for "computer-to-photoc" and "computer-to-computer" telephony services, certain ILECs

are: (1) refusing properly to provision local business lines to terminate phone-to-phone IP telephony services, (2) taking down local business lines that they discover are being used to terminate such calls, or (3) using Calling Party Number identifiers to assess **interstate** (and intrastate) access charges on phone-to-phone IP telephony calls that terminate over reciprocal compensation trunks.

The unilateral actions of ILECs have thus given rise to actual controversies over the applicability of interstate access charges to AT&T's phone-to-phone IP telephony services. Plainly, only a **ruling** from this Commission can resolve these controversies. Further, a federal decision on this issue is important for the additional reason that it will provide leadership and guidance to the states. State **commissions** have recognized the importance of uniform rules governing emerging Internet and other services and have chosen to follow the federal rule in making their determinations of the applicability of intrastate access charges to any jurisdictionally intrastate services. But contrary to decisions of other state commissions, the NYSPSC has recently construed the Commission's decisions to require access charges assessments on these services. A declaratory ruling will allow states to achieve uniformity.

For reasons set forth in more detail below, the Commission should now hold that AT&T's phone-to-phone IP telephony services are exempt from access charges applicable to circuit switched interexchange calls. This is so for two separate reasons.

First, whatever the case with the other "forms" of phone-to-phone IP telephony services, the AT&T services at issue here are provided over the Internet and required large investments to upgrade Internet backbone facilities and to enable them to carry high quality voice as well as data. The congressional mandate of "preserving" a "competitive free market . . . for the Internet" dictates that providers of Internet telephony services be permanently free to

obtain local services to originate or terminate Internet traffic and be exempt from requirements that they order and pay for access services provided at rates that are above-cost and inefficient. Any other rule would effectively sanction taxes on the Internet.

Second, even if AT&T's services were provided over ordinary private interexchange facilities using IP, the incumbents' self-help measures are inconsistent with the Commission's "wait and see" policy of exempting all VOIP services from above-cost access charges until the market had matured and the Commission could comprehensively address the proper regulatory treatment of them. This policy was sound – and remains so. Prematurely to subject new technologies to inefficient charges could block their development and risk unlawful discrimination among services (computer-to-computer, computer-to-phone, and phone-to-phone) that make identical uses of local exchange for identical purposes. The Commission should ratify its *de facto* access charge exemption and formally impose a moratorium on any access charge assessment on VOIP services pending the Commission's adoption of rules that determine the appropriate charges and that allow them prospectively to be nondiscriminatorily applied to all similarly situated providers.

BACKGROUND

To place the issues in context, it will be helpful to describe: (1) the ISP exemption, (2) the Internet and Internet Telephony, (3) the Commission's 1998 *Universal Service Report* and the contemporaneous statements of individual Commissioners, (4) the April, 1999 U S West Petition For a Declaratory Ruling, (5) the IP telephony services that AT&T and competing providers now offer, and (6) the actions of the incumbent LECs that give rise to the present actual controversy.

1. ISP Exemption. Under the Communications Act of 1934, the Commission could have required all interstate users of local exchange facilities to pay the same switched per minute access charges that apply to the circuit switched services of interexchange carriers.¹ But the Commission has refused to do so. Instead, it has given providers of enhanced and information services ("ISPs") the option of acting as end users and subscribing to flat-rated business line and other local end user services.²

The Commission originally adopted this exemption in 1983 as a temporary measure that would protect *the financial* viability of the [lien-Hcdgliny ISPs and that would eventually be phased out and eliminated.³ But following the enactment of the Telecommunications Act of 1996, the Commission found that the exemption served more fundamental purposes and that it should apply permanently, pending the adoption of new federal access arrangements applicable to advanced services.

In particular, the Commission noted that "had access rates applied to ISPs over the past 14 years, the pace of the development of the Internet and other services may not have been so rapid."⁴ The Commission made the exemption permanent on the ground that it would protect emerging and evolving technologies from the adverse effects of uneconomic charges and would advance the 1996 Act's policy of preserving "the vibrant and competitive free market

¹ See, e.g., *MTS and WATS Market Structure*, 97 FCC 2d 682, ¶ 77 (1983) (stating that the Commission's "objective" under the Act is "distributing the costs of exchange access in a fair and reasonable manner among all users of access service, irrespective of their designation as a carrier or private customer"). In this regard, the Commission's historical (and the 1996 Act's) distinctions between telecommunications carriers and enhanced and information service providers ("ISPs") determines whether these services are to be regulated, and it is irrelevant to the question of what each provider pays for local facilities that originate and terminate their services.

² See *id.*

³ See *id.*

⁴ *Access Charge Reform*, First Report and Order, 12 FCC Rcd. 15982, ¶ 344 (1997) ("Access Charge Reform").

that presently exists for the Internet and other interactive computer services.”⁵ In particular, it noted that while it has reformed access charges, they continue to be “not-cost based and inefficient” and that it could have detrimental and disruptive effects to extend the charges to information services that were “still evolving.”⁶ The Commission also rejected claims that the nonassessment of above-cost access charges resulted in undercompensation of incumbent LECs, and noted that local service charges could fully compensate LECs for the legitimate economic costs they incur in providing their facilities.⁷ Finally, the Commission stated that “it is not clear that ISPs use the public switched network in a manner analogous to IXCs”,⁸ and the Commission instituted a proceeding to consider “new approaches” and alternatives to access charges for ISPs’ use of circuit-switched network technology.”

The Court of Appeals for the Eighth Circuit upheld the permanent ISP exemption and rejected the claim that it generically gave rise to unlawful discrimination between IXCs and ISPs.¹⁰

2. The Internet And VOIP Telephony. The public Internet is comprised of a number of Internet “backbone” facilities that all have websites connected to them and they are interconnected to one another through peering arrangements. AT&T WorldNet and AT&T Broadband are Internet Service Providers, and AT&T owns and operates one of the world’s largest “common” Internet backbone facilities. It carries the traffic of AT&T’s ISPs and transmits public Internet traffic generally.

⁵ *Id.* (quoting 47 U.S.C. § 230(b)(2)).

⁶ *Id.* ¶¶ 344-45.

⁷ *Id.* ¶ 346.

⁸ *Id.* ¶ 345.

⁹ *Id.* ¶ 348.

¹⁰ *Southwestern Bell Telephone Co. v. FCC*, 153 F.3d 523, 542 (8th Cir. 1998).

The Internet transmits information in Internet Protocol (IP). IP networks break information into individual packets at the point of origination, separately route the packets over Internet backbone or other transmission facilities, and reassemble the packets and the message at the terminating end.

Although the Internet was developed to transmit data, voice signals can be converted into IP packets, and transmitted over *Internet backbone or other IP networks*. By installing microphones and software in PCs that translate voice signals into IP packets and vice versa, users of ISP services have long had the ability to place “computer-to-computer” voice calls over the Internet – without their ISP ever knowing it. The called party’s PC would convert his or her voice into IP packets, and these would be transmitted over phone lines and the Internet to the called party’s PC, where they would be converted from IP packets back to voice signals.

But these “do-it-yourself” computer-to-computer telephone calls were exceedingly limited in utility and of very poor quality. Real time computer-to-computer voice communications can only occur among persons who are on-line at the same time with active Internet connections. Further, the resulting transmissions were characterized by irregular delays, gaps, and garbled sounds because the Internet backbone facilities did not have the addressing, routing, and control systems that allow the kinds of high quality voice transmissions that circuit switched services produce. To produce that quality would require substantial investments in specialized IP infrastructure (including gateways, access routers, gatekeepers, directory servers, and accounting servers) to track each voice transmission and assure it is *disassembled and reassembled accurately and in real time*. The gateway facilities also perform conversions of voice signals from circuit switched protocol (TDM) to IP and enable calls to be placed to and *from ordinary phones*.

While circuit switched transmissions dominate interexchange voice now and will do so for the foreseeable future, investments to allow **quality voice over IP** – and the expansion of the capacity of IP networks to **handle increased voice usage** – have tremendous potential. By allowing voice and data to be transmitted over a single network, these investments can produce enormous efficiencies by allowing the integrated provision of an array of voice, data and enhanced services.¹¹ But these future services will not develop unless providers first develop the capability to offer high quality voice services over Internet backbone facilities or other IP networks, and that requires that there be an initial economic reason to make the necessary investments. A rule that authorizes VOIP providers to subscribe to local services, rather than above-cost access charges, can provide that economic reason until such time as enhanced voice and other services can be provided over the upgraded IP facilities.¹²

Beginning in the mid 1990's certain firms began to make investments that created limited capacity to provide quality voice services over the Internet or other networks using Internet Protocol. In addition to allowing higher quality voice computer-to-computer calls, these services can allow voice calls to be placed from computers to ordinary touch-tone or rotary dialed phones, from phones to phones, or from phones to computers by using the "gateways" (described above) to perform necessary conversions from voice protocol (TDM) to Internet protocol.

For example, a phone-to-phone IP call will travel over the public switched network to a local gateway where it is converted to Internet Protocol and then routed over the Internet backbone to a terminating gateway, where it is converted back to voice and sent over

¹¹ Probe Research, Inc., *VoIP Connectivity for the Enterprise*, 3 Advisory, Insight and Market Strategy (AIMS) Service Report 1-14 (2002) ("2002 Probe Research Report"); Probe Research, Inc., *Voice over Packet Markets*, 2 CISS Bulletin 11-16 (2001) ("2001 Probe Research Report").

¹² See 2002 Probe Research Report, at 6-7, 31-32; 2001 Probe Research Report, at 11.

local exchange facilities to the called party. These calls are sent and received in voice (TDM) protocol, and effect no net change in format. These services can be offered through two-stage dialing arrangements in which the caller dials a local or 800 number to reach the gateway and then dials the phone number of the called party. Or they can be offered through arrangements in which the provider subscribes to an originating Feature Group D access service and allows the subscriber to place calls by dialing 1 plus the called party's number.

Computer-to-phone calls can follow precisely the same path as phone-to-phone calls, and all computer-to-phone IP calls use the same terminating facilities as phone-to-phone calls. For example, if a computer user has a dial-tip configuration, she, too, would dial either an 800 number or a local number to reach the gateway to the IP network and would then dial the called party's number.¹³ However, because the originating PC converts the signals to IP, no protocol conversion occurs in the originating gateway, and this is the only necessary difference between a phone-to-phone and computer-to-phone IP call. Most pertinently, all phone-to-phone and all computer-to-phone calls are terminated in identical ways, in identical protocols, and over identical local exchange facilities. Whether the call is translated into IP in the originating computer (as in a computer-to-phone call) or in the originating gateway (as in a phone-to-phone call), the IP packets will be routed over the IP network, converted back to voice signal protocol (TDM) in the terminating gateway, and routed to the called party over local exchange facilities in voice signal format. The one necessary distinguishing feature of a computer-to-phone call is that

¹³ Computer-to-phone calls can also be originated over "always on" connections that users obtain by subscribing to DSL service (or to ISPs who bundle DSL access with their services) or by subscribing to cable modem services. But regardless of how the computer-to-phone calls are originated, they are terminated in the same format and over the same local exchange facilities as phone-to-phone calls.

because the protocol conversion occurs in CPE (the originating computer), the call enters the originating local exchange in IP protocol, and exits the terminating exchange in voice protocol, such that there is a net change in protocol in the end-to-end telephony service.

3. The 1998 Universal Service Report.¹⁴ The Commission issued this report to address the question of whether and to what extent services offered over the Internet should contribute directly to universal service support. Because § 254¹⁵ requires mandatory support to be provided only by “telecommunications services,” this analysis turned on whether particular services were classified as “information services” or “telecommunications services.”¹⁶ The Report addressed the emerging voice over Internet Protocol telephony services and discussed not only whether they are telecommunications services that must provide explicit USF support under § 254, but also the separate question of how the services should be regulated and, in particular, whether they must pay access charges.

The Report described VOIP telephony as services that “enable real-time voice transmission using Internet Protocols” and that it can be “transmitted along with other data on the ‘public’ Internet or routed over private data or other networks that use Internet Protocol.”¹⁷ The Report identified two basic ways in which the services are offered as: (1) computer-to-computer services in which calls are transmitted end-to-end in IP protocol, with the computers on each end performing the protocol conversion from voice to IP and back¹⁸ and (2) services that employ gateways that perform necessary protocol conversion and allow users to “call from

¹⁴ *Federal-State Joint Board on Universal Service, Report to Congress*, 13 FCC Rcd. 11,501, ¶¶ 13-15 (1998) (“*Universal Service Report*”).

¹⁵ 47 U.S.C. § 254.

¹⁶ *Universal Service Report*, ¶ 32.

¹⁷ *Id.* ¶ 84.

¹⁸ *Id.* ¶ 87.

their computer to telephones connected to the public switched network or from one telephone to another.”¹⁹

But the *Report* addressed the classification of only the two types of VOIP configurations in which the IP network effects no change in protocol or format and that clearly constitute “telecommunications:” the computer-to-computer calls (that enter and exit the network in IP) and the phone-to-phone calls (that enter and exit in voice (TDM) protocol).

In the case of computer-to-computer calls, the *Report* stated that whether or not they are “telecommunications,” the ISPs whose services enable these calls to be made do not appear to be providers of “telecommunications services.” insofar as they do not hold themselves out as providing telecommunications and may not even be aware that their services are used for telecommunications.²⁰ The *Report* did not address the computer-to-computer calls that use capabilities that are actively marketed or promoted by ISPs or other service providers.

By contrast, the Commission tentatively reached the opposite conclusion for “phone-to-phone IP telephony,” which it defined as services: (1) in which the provider holds itself out as providing telephony, (2) which use the same CPE as ordinary phone calls, (3) which allow customers to call telephone numbers assigned in accordance with the North American numbering plan, and (4) which transmit information without change in content or format.²¹ The Commission stated that such services appear to “bear the characteristics of telecommunications services.”²²

However, the Commission emphasized that these were all tentative determinations that addressed “emerging services” and that it could not make “definitive

¹⁹ *Id.* ¶ 84.

²⁰ *Id.* ¶ 87.

²¹ *Id.* ¶ 88.

²² *Id.* ¶ 89.

pronouncements” until it had a more complete record “focused on individualized service offerings.”²³ It noted that there are a “wide range of services that can be provided using packetized data and innovative CPE” and that future proceedings would have to determine if its tentative definitions had “accurately distinguish[ed] between phone-to-phone and other forms of IP telephony” and was not “likely to be quickly overcome by changes in technology.”²⁴

The *Report* stated that future proceedings would also address the regulatory obligations that would apply to “phone-to-phone” providers if they were held to be providing “telecommunications services” and thus to be “telecommunications carriers.”²⁵ The Commission acknowledged that there was one necessary consequence to such a classification, for providers of telecommunications services “fall within section 254(d)’s mandatory requirement to contribute to universal service mechanisms.”²⁶

But the Commission recognized that classification of phone-to-phone IP telephony as a “telecommunications service” did *not* mean that the services would automatically be subject to the same interstate access charges that circuit switched interexchange services pay.²⁷ To the contrary, the Commission stated only that “to the extent we conclude that certain forms of phone-to-phone IP telephony services are ‘telecommunications services’ and to the extent the providers of those services obtain the same circuit-switched access as obtained by interexchange carriers, and therefore impose the same burdens on the local exchange as do other interexchange carriers, we *may* find it reasonable that they pay *similar* access charges.”²⁸ In this regard, the Commission stated that its future proceedings “likely will face difficult and contested

²³ *Id.* ¶ 90.

²⁴ *Id.*

²⁵ *Id.* ¶ 91.

²⁶ *Id.* ¶ 92.

²⁷ *Id.* ¶ 91.

²⁸ *Id.* (emphasis added).

issues relating to the assessment of access charges on these providers,” such as whether LECs can “determine where particular phone-to-phone IP telephony calls are interstate, and thus subject to the federal access charge regime, or intrastate.”²⁹

Commissioner Furchgott-Roth dissented from the Commission’s *Report*. He stated that even tentative distinctions between computer-to-computer and computer-to-phone services were arbitrary because phones could be developed that perform the same protocol conversions as computers and that there could be no rational basis to subject one service to a “tax” but not the other.³⁰

Then-Commissioner Powell separately concurred. He expressed concern that even the tentative classifications went too far, noting that the “infinite flexibility of IP switched networks” meant that distinctions between voice and data were “difficult if not impossible to maintain.”³¹ He stated that it could “stifle innovation and competition in direct contravention of the Act” if “innovative new IP services” were “all thrown into the bucket of telecommunications carriers” and subject to the same “regulations and their attendant costs.”³² Shortly thereafter, then-Chairman Kennard stated that he opposed any “new taxes or fees on IP telephony.”³³

4. The U S West Petition And The Subsequent Developments. Providers of IP telephony and others³⁴ understood the *Report* as holding that phone-to-phone and other

²⁹ *Id.*

³⁰ *Universal Service Report* at 11,636-37 (1998) (Furchgott-Roth, Commissioner, dissenting in part).

³¹ *Id.* at 11,623 (Powell, Commissioner, concurring).

³² *Id.*

³³ Chairman William E. Kennard, Remarks Before the Voice Over Net Conference, Atlanta, Georgia (Sept. 12, 2000).

³⁴ See Testimony of Chairman Patrick Wood, Texas Public Utilities Commission, before Texas House of Representatives Committee on State Affairs, Subcommittee on Cable and Broadband, *Transcript of Proceedings*, pp. 32-34 (May 2, 2000) (“The FCC has said that [Voice Over Internet] does not pay access charges” at least until such time as a large percentage of “all the voice traffic in America [goes] over the Internet.”).

IP telephony services would be exempt from interstate access charges and subject to the ISP exemption – either *de jure* or *de facto* – until the conclusion of future proceedings that would determine whether “certain forms” of this service should be subject to “similar” charges. They therefore continued to use end user or other local services to terminate and in some cases to originate VOIP telephony services.

On April 5, 1999, U S West filed a Petition For An Expedited Declaratory Ruling that access charges apply to “phone-to-phone IP telephony services,” which U S West there defined as services that satisfy the *Universal Service Report*’s four-part definition of this term *and* that are *not* provided by IXCs or other parties using the public Internet.³⁵ U S West stated that AT&T, Sprint, and an array of carriers were providing these services, but were refusing to order access services to terminate and (in some cases) to originate their traffic. Instead, they were terminating their traffic over local business lines or through CLECs that interconnect with the incumbent LEC and terminate calls to the incumbent’s customers through cost-based reciprocal compensation arrangements.³⁶ U S West contended that these phone-to-phone IP services are “telecommunications services” within the meaning of the Act and that they were therefore required to use access services and to pay access charges.³⁷

U S West stated that it was not asking the Commission to create a new rule or to alter an existing rule, but was only seeking to enforce existing policies. But U S West nowhere attempted to square its request with the *Universal Service Report*’s express holding that even if phone-to-phone IP telephony services were classified as telecommunications services, the Commission would have to address “difficult and contested issues” before it could subject these

³⁵ See *Petition of U S West, Inc. for Declaratory Ruling Affirming Carrier’s Carrier Charges on IP Telephony*, Petition for Expedited Declaratory Ruling at ii, 1 (filed with FCC Apr. 5, 1999).

³⁶ See *id.* at 3.

³⁷ *Id.* at ii.

services to access charges that are even “similar” to those applicable to circuit switched interexchange services.³⁸ The Commission did not issue a Public Notice of the U S West petition or otherwise seek comment on it.

In the ensuing years, there has been slow, but steady growth, in phone-to-phone and other VOIP services. Net-2-Phone, Genuity, Level 3, and other firms have developed wholesale services that enable providers of prepaid cards, international, and other services to offer retail services that are terminated over IP networks of wholesale providers and the terminating local exchange services that the wholesale providers obtain.³⁹ At the same time, Net-2-Phone and other firms who initially offered retail services that allowed higher-quality computer-to-computer and computer-to-phone services are now providing retail services that can be accessed either from phones or from PCs.⁴⁰ The foregoing services do not pass information that would enable LECs to determine whether particular calls are phone-to-phone IP telephony services or computer-to-phone or other enhanced services.

During the ensuing years, various types of CPE have been developed that convert voice signals into IP. IP phones and IP PBXs have been developed and previously installed PBXs can be upgraded to perform those conversions.⁴¹

5. AT&T’s VOIP Services. AT&T has the nation’s largest circuit switched long distance network. Although IP will likely prove to be a more efficient technology for stand-alone voice traffic and has enormous future potential to permit new services and to allow the integrated provision of voice, data, and enhanced services, AT&T requires affirmative economic

³⁸ *Universal Service Report*, ¶ 91.

³⁹ See, e.g., 2002 Probe Research Report, at 20-24; Wylie Wong, *Net2Phone To Offer Services to Small Businesses*, CNET News.Com., Feb. 22, 2000, available at www.news.com.com/2100-1033-237122.html?tag=rn (offering details of Net2Phone’s IP Telephony services).

⁴⁰ See 2002 Probe Research Report, at 20-27.

⁴¹ See generally *id.*

savings before it can justify making investments that would allow it to begin even to transition ordinary voice traffic to IP, and AT&T cannot now serve more than a small fraction of existing circuit switched traffic over its common IP backbone. But in response to the Commission's *de jure* and *de facto* exemptions of phone-to-phone IP telephony from access charges and in recognition of IP's future potential, AT&T has undertaken to use its common Internet backbone to provide limited VOIP services. AT&T has upgraded its Internet backbone by installing: (1) IP gateways that convert circuit switched signals into IP voice packets and vice versa and perform address routing for these packets and (2) specialized IP infrastructure (e.g., routers, gatekeepers, directory servers, and accounting servers) that monitor, control, and otherwise assure the quality of the voice over IP transmissions.

AT&T initially test marketed a service called Connect-N-Save. This service used a two-stage dialing arrangement in which customers would access a gateway by dialing a local number or an 800 number, and in which the call would be routed over IP to a terminating gateway, where it would be routed to the called party over local exchange facilities. Although AT&T paid access charges on the originating end of the call when customers used 800 access, AT&T terminated the calls through ILEC local business lines or via CLEC local business lines that interconnect with incumbent's networks at cost-based per minute reciprocal compensation charges, rather than above-cost terminating access charges. However, Connect-N-Save was not a successful service, and AT&T has withdrawn the service in the few states where it was test marketed.

To make current use of the IP investments that allow voice and other services to be offered, AT&T has made arrangements that use one-stage dialing and that move a small fraction of its voice traffic to its Internet backbone. These calls are routed over Feature Group D

access lines with customers reaching AT&T's local IP gateway by dialing one plus the called number. so originating access charges are paid on these calls (just as they were paid on the Connect-N-Save calls that used 800 access). But as in Connect-N-Save, AT&T does not order access services to terminate these calls, but terminates them over CLEC or ILEC local business lines, with the CLEC terminating the call over reciprocal compensation trunks if the called party is an ILEC customer.

Some of the traffic that AT&T is routing through this arrangement consists of enhanced services: prepaid calling card services that includes advertising announcements. This traffic was offered on a nontariffed basis prior to the August 1, 2001 effective date of the Commission's *Detariffing Order*⁴². The balance of the traffic that uses this IP transmission arrangement consists of both interstate and intrastate "phone-to-phone IP telephony service," within the *Universal Service Report's* definition of that term. Where technically feasible, AT&T passes the Calling Party Number ("CPN") on both types of traffic.

6. The Controversy Over Interstate Access Charges. When AT&T had initially rolled out its phone-to-phone VOIP services, it had intended to terminate the calls in local calling areas over local business private lines ("primary rate interface" or "PRI" trunks) that connect the AT&T gateway to local exchanges. However, certain ILECs have blocked these arrangements through various forms of self-help. Certain LECs have refused properly to provision the requested PRI facilities and have begun assessing terminating access charges on the alternative arrangements that AT&T has procured. Other LECs provisioned the PRI facilities, but subsequently refused to terminate VOIP traffic over them and have threatened to disconnect the

⁴² See *Policy and Rules Concerning The Interstate, Interexchange Marketplace*, Second Report and Order, 11 FCC Red. 20,730 (1996) ("*Interstate Interexchange Marketplace*").

facilities unless AT&T removes its VOIP traffic from them and orders access services to terminate it.

For example, when AT&T ordered these local exchange facilities in Virginia, Verizon refused to provision the facilities as AT&T requested. Verizon took the position that although AT&T could order local business lines to terminate traffic that originates on computers, AT&T could not do so on VOIP traffic that originates on ordinary telephones. AT&T thus instead obtained private lines from its local service area and other CLECs, who would directly terminate the enhanced and basic voice calls to their own local subscribers and would terminate calls to Verizon's subscribers over reciprocal compensation trunks. AT&T thus would pay cost-based reciprocal compensation rates to terminate calls to Verizon customers over Verizon's local switches and loops, rather than paying above-cost access charges.

Beginning at the end of last year, Verizon began examining the CPN on calls that terminate on these reciprocal compensation trunks and began assessing access charges on certain of the calls based on their CPN. It has thus billed AT&T for interstate access charges on certain calls and for intrastate access charges on others, while charging local reciprocal compensation charges only on calls with local CPN. The calls on which Verizon has assessed interstate and intrastate access charges include the prepaid calling card calls that are enhanced services as well as phone-to-phone IP telephony calls. AT&T has advised Verizon that it is disputing all these charges, and that AT&T will be entitled to a refund of the full amounts in question (plus interest) if and when the Commission grants the declaratory ruling that AT&T is here requesting.

Other incumbent LECs have the capacity to examine the CPN on calls terminating on reciprocal compensation trunks or other local facilities, and AT&T understands that they, too, have begun to examine CPN on this traffic.

In this regard, Sprint had recently begun refusing to terminate AT&T's VOIP calls over Sprint local business lines in Tallahassee, Florida. Indeed, rather than continuing to terminate these calls, Sprint initially began to route ilic calls to "dead air," forcing AT&T to re-route traffic to avoid call disruption and adverse customer impacts, and Sprint had threatened to disconnect the circuits unless AT&T agreed to move all this traffic off of them and onto access circuits. Sprint then threatened to disconnect circuits in other areas as well. When AT&T complained that Sprint's actions are unlawful, Sprint resumed terminating the traffic, but opened a billing dispute in which it claims that access charges apply to this traffic.

7. State Decisions and Controversies. In proceedings before state utility commissions, incumbent LECs have contended intrastate access charges can be imposed on providers of phone-to-photoc IP telephony services that are jurisdictionally intrastate. In recognition of the importance of uniform policies on the application of access charges to Internet and other emerging services, states have generally followed the federal rule applicable to interstate traffic in determining whether jurisdictionally intrastate traffic is subject to **intrastate** access charges. But states have reached different and inconsistent results.

In proceedings under §§ 251 and 252 of the Act, two state PUCs have declined to authorize the assessment of access charges on phone-to-plinec IP telephony services. The Colorado PUC has held that incumbent LECs may not assess switched access charges as compensation for the use of their networks to terminate phone-to-phone IP telephony services.⁴³ Similarly, the Florida PSC has noted that this Commission has deferred the question of the applicability of access charges to this traffic to future proceedings and decided, over BellSouth's

⁴³ *Petition by ICG Telecom Group, Inc., for Arbitration of an Interconnection Agreement with U.S. West Communications, Inc.*, No. C00-858 (Colo. Pub. Util. Comm'n Aug. 1, 2000) (finding that voice over internet protocol services are not subject to switched access charges).

objection, that it would not address the question whether access charges should apply to phone-to-phone VOIP traffic.⁴⁴

However, in another proceeding, the New York Public Service Commission (NYPSC) held that providers of intrastate phone-to-phone IP telephony services are required to pay intrastate access charges on calls that originate and terminate in that state.⁴⁵ The IP telephony provider had there contended that the assessment of access charges was contrary to federal policies. While the NYPSC undertook to follow federal policy, it reviewed the *Universal Service Report* and determined that access charges should apply to intrastate phone-to-phone IP telephony services because they are a "telecommunication service," rather than an information or enhanced service under federal law. Ironically, the NYPSC relied on the Commission's statement in the *Universal Service Report* that it "may find it reasonable" that IP telephony providers pay "similar" access charges in future proceedings. The NYPSC ignored the Commission's use of the qualifying word "may," its statement that the issues would be "difficult and contested,"⁴⁶ and its statement that access charges would only be imposed in the future. By contrast, Texas PUC Chairman Patrick Wood had read this language as the Commission's holding that VOIP services will not be subject to access charges.⁴⁷

ARGUMENT

Under the Administrative Procedure Act and the Commission's rules, the Commission has jurisdiction to "issue a declaratory order to terminate a controversy or to

⁴⁴ *Investigation into Appropriate Methods To Compensate Carriers for Exchange of Traffic Subject to Section 251 of the Telecommunications Act of 1996*, No. 000075-TP (Fl. Pub. Serv. Comm'n Nov. 21, 2001).

⁴⁵ *Complaint of Frontier Telephone of Rochester Against US DataNet Corporation Concerning Alleged Refusal to Pay Intrastate Carrier Access Charges*, No. 01-C-1119 (N.Y. Pub. Serv. Comm'n May 31, 2002).

⁴⁶ *Id.* at 8 (emphasis added).

⁴⁷ See p. 15 n.34, *supra*.

remove uncertainty.”⁴⁸ The applicability of access charges to phone-to-phone and other forms of IP telephony now presents a controversy that requires resolution by the Commission.

Foremost, incumbent LECs have created a controversy over the applicability of interstate access charges to phone-to-phone IP telephony services by engaging in self-help. After failing to persuade the Commission to declare that providers of these services must order interstate access services, individual incumbent LECs have begun to refuse properly to provision end user services to terminate these services, to refuse to complete calls over facilities that were previously provisioned, and to assess interstate access charges on calls from other states that are terminated through CLECs and the ILECs’ reciprocal compensation trunks. Rather than litigating the lawfulness of these ILEC actions on piecemeal case-by-case bases, AT&T is bringing this petition for a declaratory ruling that interstate access charges cannot now be assessed on this traffic and that AT&T is lawfully terminating the traffic over local business lines. Accordingly, a declaratory ruling is here required to resolve an actual controversy that is within the Commission’s exclusive jurisdiction.

Further, by issuing the requested ruling, the Commission will also be providing leadership and guidance to states, who recognize that uniform rules should govern the applicability of above-cost access charges (be they interstate or intrastate) to VOIP telephony and who have endeavored to follow the federal rule in determining the applicability of intrastate access charges to Internet and other such traffic. That the NYPSC has reached a different conclusion on the applicable federal rule than have two other state commissions underscores the need for the Commission to exercise leadership on this issue and to clarify the federal rule.

⁴⁸ 5 U.S.C. § 554(e); see 47 C.F.R. § 12

As detailed below, there are two separate reasons why the ILECs' access charge assessments on AT&T's phone-to-photoc IP telephony services should be declared unlawful

I. BECAUSE AT&T'S PHONE-TO-PHONE IP AND OTHER SERVICES ARE PROVIDED OVER THE INTERNET, THEY MUST BE EXEMPT FROM REQUIREMENTS THAT THEY PURCHASE ACCESS SERVICES OR PAY ACCESS CHARGES.

First, whatever is the case with calls over "private" interexchange networks that use Internet Protocol, AT&T's IP-based services are provided over the Internet itself. The Internet is comprised of the various "common" Internet backbone facilities that are connected to websites and that are interconnected to one another through peering arrangements. The calls at issue are transmitted over the same "common" Internet backbone facilities that carry ISP and all other types of public Internet traffic. And, as detailed above, the provision of VOIP services over the Internet required AT&T to make large investments in IP technologies that upgraded its common Internet backbone facilities to allow them to transmit voice messages at the same levels of quality that have been provided by AT&T's circuit switched long distance network. These investments were further necessary to achieve the ultimate benefits of IP – the provision of voice, data, and enhanced services on an integrated basis – and AT&T is now providing enhanced voice prepaid card services as well as basic phone-to-phone IP telephony over these upgraded facilities. Voice service has now become one IP application of AT&T's Internet backbone, and the investments will allow a range of future interactive voice and other enhanced services.

It should be self-evident that, whatever the case with the forms of phone-to-phone IP telephony services that merely use Internet Protocol, above-cost and inefficient access charges cannot be applied to phone-to-phone telephony services that are transmitted over the Internet itself. U S West recognized this point in its April 1999 petition for a declaratory ruling. That

petition expressly excluded calls that are transmitted over the Internet from its definition of the phone-to-phone IP telephony services that, in U S West's view, were required to order originating and terminating access services and to pay access charges.⁴⁹

The reality is that few things would be potentially more destructive of the development of the Internet than would a rule that prohibited Internet services from using local services to reach end users and that required that they pay the access charges that have been found to have rate structures that are "above-cost" and "inefficient."⁵⁰ That would be the equivalent of a tax on the Internet, and would be flatly contrary to the congressional decree that the Commission "preserve the free and competitive market that presently exists for the Internet and other interactive computer services, unfettered by Federal or state regulation."⁵¹ A free and competitive market is one in which providers are free to subscribe to services that are efficient and are not artificially required by regulation to use services that have rate structures that are "above-cost" and "inefficient."⁵²

II. THE ILECS' ACCESS CHARGE ASSESSMENTS VIOLATE THE COMMISSION'S POLICY OF EXEMPTING PHONE-TO-PHONE IP TELEPHONY SERVICES FROM ACCESS CHARGES PENDING FUTURE COMMISSION ACTION.

Second, even if AT&T's phone-to-phone services merely used IP in a "private" interexchange network, the incumbent LECs' access charge assessments are quite clearly contrary to the policy that the Commission has followed over the past five years. The Commission has followed a "wait and see" policy in which all nascent phone-to-phone

⁴⁹ See *Petition of US WEST, Inc. for Declaratory Ruling Affirming Carrier's Carrier Charges on IP Telephony*, at 1.

⁵⁰ See *Access Charge Reform Price Cap Performance Review for Local Exchange Carriers*, Notice of Proposed Rulemaking, Third Report and Order, and Notice of Inquiry, 11 FCC Red. 21354 ¶ 214 (1996) ("Price Cap Performance Review").

⁵¹ 47 U.S.C. § 230(b)(2).

⁵² *Price Cap Performance Review*, ¶ 214.

IP telephony and other VOIP services were treated as exempt from access charges at least until the services had matured and the Commission could consider the proper treatment of them on a complete record. As the *Universal Service Report* stated, the Commission would then determine whether access charges "similar" to those applicable to interstate circuit switched services should apply to "certain forms" of these services and could adopt rules that allow their nondiscriminatory assessment on all similarly situated providers of VOIP services.⁵³

This is a policy that the Commission had previously been able to pursue through the simple device of repeatedly refusing the incumbents' requests for a ruling that providers of phone-to-phone IP telephony services are required to order originating and terminating access services and to pay access charges. In particular, the refusal to decide the issue had – until recently – meant the providers of phone-to-phone and other VOIP services could, and did, originate and terminate their services over end user local services and that they all enjoyed the ISP access charge exemptions, either *de jure* or *de facto*. However, because incumbents have now resorted to self-help, denied end user services to phone-to-phone IP telephony providers, and unilaterally assessed access charges, the incumbents have forced the Commission to address the issue expressly. It should now do so by formally ratifying the policy it has long followed and hold that phone-to-phone IP services will be immune from access charges unless and until the Commission adopts rules that provide for prospective assessment of the charges on some or all of these services.

There are multiple, compelling reasons for the policy that the Commission has long followed. They all dictate that the policy now be formalized in a Commission ruling that

⁵³ *Universal Service Report*, ¶ 91

bars the self-help measures of the incumbents and exempts all VOIP services from access charges pending the adoption of prospective rules.

First. IP telephony service offerings are innovative and experimental services that represent a tiny fraction (between 1% and 5%) of interexchange calling.⁵⁴ They use new IP technologies that allow packet switched data networks to provide voice services of a quality comparable to circuit switched networks, and providers have experimented with an array of innovative methods of pricing and provisioning these services. To prematurely subject innovative new IP services to the regulations applicable to established circuit switched services, and all their attendant costs, could stifle innovation and competition, for all the reasons that Chairman Powell identified in his concurrence to the *Universal Service Report*.⁵⁵

In this regard, even if it were clear that these new IP-based services will eventually become no more than substitutes for circuit switched long distance services – as it patently is not, see *infra* – the Commission should allow the services to establish themselves and to mature before subjecting them to the above-cost and inefficient access charges that are applicable to established circuit switched services. For IP also has the potential to achieve trunking efficiencies that could provide a more efficient means of carrying even stand-alone voice service, and the Commission's policy should be to encourage the beginning of a transition from circuit switched to VOIP services. A moratorium on access charges on initial VOIP services is critical to allow this transition to begin.

Second, IP telephony services are still evolving, and they hold the promise to be far more than substitutes for today's circuit switched interexchange services. The primary attraction of upgraded IP facilities is not the provision of stand-alone voice services, but the

⁵⁴ See 2001 Probe Research Report, at 4.

⁵⁵ See *Universal Service Report*, 13 FCC Rcd. at 11,623 (Powell, Commissioner, concurring)

integrated provision of voice, data, and enhanced services.” This is reflected, in part, in the fact that some of the voice services that AT&T provides over IP today are enhanced prepaid card voice services that are information services, not telecommunications services. More fundamentally, even the VOIP services that today have characteristics of telecommunications services may be transitional measures and may evolve into integrated services in which voice is merely one application of an integrated voice, data, and enhanced services platform. These are points that the Florida PSC cited in following the Commission’s lead and deterring the issue of the applicability of access charges to phone-to-phone IP traffic to future proceedings.⁵⁷

Third, premature determinations of the applicability of access charges risk severe discrimination that will distort competition among different services that use the same IP technologies and that have far more in common with one another than they do with circuit switched interexchange services. The *Universal Service Report* made this very point in deferring the questions whether “certain forms” of phone-to-phone IP telephony services should pay some form of access charges because the services had been tentatively classified as telecommunications services. As the Commission emphasized, the distinction that the Commission had tentatively drawn between “phone-to-phone” and other forms of IP telephony (computer-to-phone and computer-to-computer) was an extremely fragile one that could be quickly overtaken by changes in technology and the marketplace.⁵⁸

For example, the tentative determination that “computer-to-computer” services are not telecommunications services rested on the characteristics of the “do it yourself” voice

⁵⁶ See 2002 Probe Research Report, at 1-14; 2001 Probe Research Report, at 11-16.

⁵⁷ See *Investigation into Appropriate Methods To Compensate Carriers for Exchange of Traffic Subject to Section 251 of the Telecommunications Act of 1996*, No. 000075-TP (Fl. Pub. Serv. Comm’n Nov. 21, 2001).

⁵⁸ *Universal Service Report*, ¶ 90.

services that ISPs subscribers can and have cobbled together without the knowledge or assistance of ISPs and that used Internet backbone facilities that had not been upgraded to allow quality real time voice transmission. These are services that ISPs and others plainly did not hold themselves out as offering, and the Commission relied on that fact in concluding that these are not telecommunications services.⁵⁹ However, ISP and other offerings have emerged which expressly offer and promote capabilities of IP networks that allow circuit-switched-quality voice transmissions between computers (and between phones). These computer-to-computer services quite plainly are telecommunications services under the *Universal Service Report's* rationale, and it would distort competition in violation of the Act if these services were exempt from access charges while other VOIP services were subject to them.

Similarly, as the *Universal Service Report* suggested, the "wide range of services that can be provided using packetized voice and innovative CPE" mean that the tentative distinction between "computer-to-computer" services and "phone-to-phone" services is one that can be "quickly overcome by changes in technology."⁶⁰ That observation was prescient. Today, many types of CPE perform precisely the same protocol conversion functions that are performed by computers and that were the sole basis for the tentative decision to classify "phone-to-phone" services differently than "computer-to-phone" services.⁶¹

Most fundamentally, while the *Universal Service Report's* tentative distinctions are no longer sustainable, the ultimate question presented here relates not to the proper

⁵⁹ *Id.* ¶ 87

⁶⁰ *Id.* ¶ 90.

⁶¹ *Id.* ¶ 89. There is one other attribute that the *Universal Service Report* cited to distinguish phone-to-phone from phone-to-computer and computer-to-computer services: whether the call is addressed to numbers assigned to the North American Numbering Plan ("NANP") rather than to the TC/IP address of a particular computer. See *id.* ¶ 88. This distinction is particularly artificial because even if a call is addressed to a computer, the computer will, in many instances, be plugged into a telephone line that has an NANP telephone number.

regulatory classification of various services, but whether incumbent LECs may discriminate among them by requiring all or some IP telephony providers to pay access charges and by exempting other providers of VOIP services from those charges. The answer to that question does not turn on the distinction between phone-to-phone and other services, but rather on whether different providers are using identical facilities "in the same way [and] for the same purpose."⁶²

In this regard, the primary purpose of § 202(a) of the Act is to prevent discrimination among competing services and the resulting marketplace distortions.⁶³ Here, the decisive fact is that all types of VOIP providers compete with one another through IP technologies, and they all use identical local exchange facilities for the same purposes. Most starkly, all phone-to-phone and computer-to-phone services are terminated in precisely the same way, for they all route traffic in voice (TDM) format from the providers' terminating gateways to called parties over circuit switched local exchange facilities.⁶⁴ Yet the incumbents would assess terminating access charges on AT&T's phone-to-phone services but not on computer-to-phone services. Beyond that, there are also no material distinctions in the uses of local facilities by any of the various forms of VOIP services, be they computer-to-computer, phone-to-phone, computer-to-phone, or phone-to-computer. It thus is critical that the Commission adopt policies that will assure that particular IP providers are not saddled with discriminatory charges that do not apply to competitors. The way to achieve this fundamental statutory object is not to allow discriminatory assessments based on the tentative distinctions in the *Universal Service Report*,

⁶² *Southwestern Bell*, 153 F.3d at 542; see *Bell Atlantic Tel. Cos. v. FCC*, 206 F.3d 1, 8 (D.C. Cir. 2000).

⁶³ 47 U.S.C. § 202(a); See *Competitive Telecommunications Ass'n v. FCC*, 87 F.3d 522 (D.C. Cir. 1996).

⁶⁴ See *supra* Part I.

but to allow all VOIP providers to enjoy the ISP exemption until the Commission can compile a complete record, determine the services that should and should not bear access charges, and adopt rules that assure nondiscriminatory assessments of whatever charges are appropriate. Formal ratification of the policy that the Commission has followed for the past years will achieve that end.

Fourth, and relatedly, until prospective regulations are adopted based on a complete record, the Commission has recognized that it would also be exceedingly "difficult," if not impossible, for access charges to be nondiscriminatorily assessed against even all providers of phone-to-phone IP telephony services.⁶⁵ In particular, the *Report* identified the difficulties of "determin[ing] whether particular phone-to-phone calls are interstate, and thus subject to the federal access charge scheme, or intrastate."⁶⁶ One reason for these difficulties is that because many firms providing only basic phone-to-phone IP telephony have had no reason to track or pass Calling Party Number, there often is no basis to identify the calls to which access charges could apply or even reliably to estimate the percentages of interstate and intrastate use on those calls that are clearly telecommunications services. Plainly, it would be perverse if AT&T's VOIP services could alone be singled out for access charges because AT&T passes CPN, while other providers of phone-to-phone IP telephony services would be exempt from these charges because they do not pass CPN.

Further, providers of phone-to-phone IP telephony use their facilities to provide enhanced as well as basic services. For example, AT&T's existing VOIP services include enhanced prepaid calling card services as well as basic voice services, and AT&T's service could be expanded to include other enhanced services and to tightly integrate the basic voice and

⁶⁵ *Universal Service Report*, ¶ 91.

⁶⁶ *Id.*

enhanced services. Similarly, other VOIP providers (e.g., Net-2-Phone) offer services that can be interchangeably used to place either computer-to-phone calls (which are enhanced), phone-to-phone calls (which have characteristics of basic services) or computer-to-computer calls (which have been held not to be telecommunications services), and there has been no occasion to develop methods to track the information that would permit determinations of which calls are telecommunications and could be subject to access charges and which are enhanced that are not subject to access charges. The practical difficulties of making nondiscriminatory access charge assessments provide a further reason for a rule barring the imposition of access charges on any VOIP providers until rules can be adopted that will allow the prospective nondiscriminatory assessment of whatever charges are found proper.

Finally, the adoption of a rule that ratifies the longstanding *de facto* ISP exemption for all VOIP services will cause no cognizable harm to incumbents or to any objective of the Act. First, quite apart from the fact VOIP represents a tiny fraction of interexchange calling, the Commission has rejected the claim that end user charges do not fully compensate incumbents for all legitimate costs.⁶⁷ In this regard, AT&T is either terminating calls over local private lines or business lines obtained from ILECs or obtaining these facilities from CLECs and terminating calls to ILEC customers over reciprocal compensation arrangements to which cost-based rates apply. In either case, the ILEC is compensated either through AT&T's payments for ILEC flat-rate local private lines or business lines purchased under end user tariffs or through reciprocal compensation payments from the CLEC to the ILEC. Further, the nonpayment of access charges has no adverse effect on universal service. AT&T pays universal service support payments on the revenues from all its non-enhanced VOIP calls that it carries over the Internet

⁶⁷ *Access Charge Reform*, ¶ 346

and that fall within the definition of phone-to-photoc IP telephony and of telecommunications services

In short, the Commission should formally clarify the policy that it has followed for the past five years of exempting all VOIP services from access charges until such time as the Commission comprehensively reviews the evolving services, determines the appropriate charges that should apply to them, and adopts appropriate prospective rules that allows their *nondiscriminatory assessment on all similarly situated service providers.*

CONCLUSION

For the reasons stated, the Commission should enter a declaratory ruling that:
(1) VOIP services that are carried over the Internet are permanently entitled to subscribe to local services and exempt from any requirement that they subscribe to access services or pay above-cost access charges, and (2) all other phone-to-photoc IP and VOIP telephony services are exempt from access charges unless and until the FCC adopts regulations that prospectively provide otherwise.

Respectfully submitted,

David W. Carpenter
Sidley Austin Brown & Wood
Bank One Plaza
10 S. Dearborn
Chicago, Illinois 60603
(312) 853-7137

David L. Lawson
Julie M. Zampa
Sidley Austin Brown & Wood LLP
1501 K Street, N.W.
Washington, D.C. 20005
(202) 730-8000

/s/ Mark C. Rosenblum
Mark C. Rosenblum
Lawrence J. Lafaro
Judy Sello
AT&T Corp.
Room 3A229
900 Route 202/206 North
Bedminster, New Jersey 07921
(908) 532-1846

October 18, 2002

CERTIFICATE OF SERVICE

I hereby certify that on this 18th day of October, 2002, I caused true and correct copies of the forgoing Petition for Declaratory Ruling That AT&T's Phone-to-Phone IP Telephony Services Are **Exempt** From Access Charges to be served on all parties by mailing, postage prepaid to their addresses listed on the attached service list

Dated: October 18, 2002
Washington, D.C.

/s/ Peter Andros

Peter Andros

SERVICE LIST

Marlene H. Dortch
Secretary
Federal Communications Commission
445 12th Street, SW
Washington, D.C. 20554

Exhibit R

Service Provider Interconnection for Internet Protocol Best Effort Service

Network Reliability and Interoperability Council V Focus Group 4: Interoperability

1. Introduction

1.1 Overview

Focus Group 4 of the Federal Communications Commission's (FCC) Network Reliability and Interoperability Council (NRIC) V is tasked with assessing and improving interoperability among data networks, including Internet providers.

There are several forms of interoperability, including interoperability of equipment within a single provider network, and interoperability related to the interconnection between provider networks. The former is primarily addressed by protocol standards and by a variety of testing efforts. This report will focus on the latter

This report deals with interconnection between Internet Service Providers. The report describes the various interconnection arrangements, which are presently in use in the Internet, and identifies some areas that affect interoperability and reliability. This report is limited to best effort Internet Protocol (IP) services. The aim is to serve as a framework for ongoing efforts, and to explain the related issues.

There are numerous aspects to interoperability among Internet networks, including:

- Routing aspects of ISP interconnection;
- Administrative and economic aspects of interconnection;
- The performance and scalability of Internet interconnections; and
- The robustness and security of Internet interconnections.

This report seeks to identify the most important issues and exposures in each of these three main areas, and strives to identify opportunities to address or mitigate these risks. Where a solution is not readily apparent, we suggest directions for future research and investigation.

There are other aspects of interconnection between ISPs, such as operational coordination of issues such as security and quality of service, which focus group 4 is not currently working on.

Few mediums have grown as quickly as the Internet, or continue to change as rapidly. We expect and acknowledge that the practices we describe and document will change over time. It is therefore likely that the issues addressed in this report will need to be revisited in the future.

1.2 Terminology

1.2.1 Acronyms

AADS	Ameritech Advanced Data Services
AS	Autonomous System
BGP	Border Gateway Protocol
CDN	Content Distribution Network
CIDR	Classless Inter-Domain Routing
CoS	Class of Service
DNS	Domain Name Service
DoS	Denial of Service
FCC	Federal Communications Commission
FG4	Focus Group 4 of NRIC
FOIA	Freedom Of Information Act
IGP	Internal Gateway Protocol
IOPS	Internet OPERations Group
IP	Internet Protocol
IS-IS	Intermediate-System to Intermediate-System routing protocol
ISP	Internet Service Provider
ISP-ISAC	Internet Service Provider - Industry Sector Advisory Committee
IT-ISAC	Information Technology - Industry Sector Advisory Committee
MAE	Metropolitan Area Ethernet/Exchange.
MPLS	Multi-Protocol Label Switching
NAP	Network Access Point
NOC	Network Operations Center
NRIC	Network Reliability and Interoperability Council
OSPF	Open Shortest Path First routing protocol
PoP	Point of Presence
SKA	Sender Keep All
TCP	Transmission Control Protocol

1.2.2 Terminology

Autonomous System	A group of routers under a single administration. See section 2.2.
Bilateral Settlements	An arrangement in which each provider invoices the originating end user, and then financial settlements are made between providers to offset originating call imbalances.
Half-circuit settlements	An arrangement in which two providers each pay part of the cost of a circuit between the providers (e.g., each pays the cost of the half-circuit from its end to the other end).

Hot Potato Routing	Same as Shortest Exit Routing.
Internal Gateway Protocol	The protocol used within an autonomous system.
Internet	The global interconnected set of IP networks.
Internet Service Provider	An organization which offers Internet IP connectivity services to customers.
Paid Peering	A form of peering in which one party pays the other, in order to offset perceived differences in cost or value received.
Peering	An agreement between ISPs to carry traffic for each other and for their respective customers. See section 2.5.
Peering policies	The decision criteria that a provider applies in deciding with whom they will peer.
Sender Keep All	An arrangement in which each provider invoices the originating end user, but no financial settlement is made between providers.
Shortest Exit Routing	A form of inter-domain routing in which a packet destined for a neighboring ISP is sent via the nearest interconnect to that ISP. See section 2.2.
Transit	An agreement where an ISP agrees to carry traffic on behalf of another ISP or end user. In most cases transit will include an obligation to carry traffic to third parties. See section 2.5.

2. Background

2.1 Basic Data Connectivity in the Internet

An Internet Service Provider (ISP) is defined to be an organization, company, or business entity which is offering IP packet connectivity as part of the public Internet. An Internet service provider might optionally also offer other services such as dial-up IP services, Domain Name Service (DNS), voice over IP, or traditional voice and circuit services, or may also be a content aggregator or content service provider that bundles content with IP transport. These other services make use of IP packet connectivity. This report focuses on basic IP packet connectivity.

The current Internet is supported by a very large number (at least thousands) of ISPs. ISPs range in size from very small (as small as serving an individual building) to very large (global). It is common for an IP packet, in its path from source to destination over the Internet, to traverse multiple ISPs. It is therefore necessary for ISPs to cooperate in the provision of Internet connectivity services. For example, it is necessary for ISPs to negotiate agreements to achieve connectivity between these various IP networks.

Typically, today in the Internet, the interface between IP service providers offers basic datagram IP interconnection, and supports only best effort IP traffic. In other words, today class-of-service (CoS) support is typically not offered across multiple ISPs. In the future ISPs may provide additional services, such as two or more classes of service and/or MultiProtocol Label Switching (MPLS). There might also be a need to support these types of services between providers. These issues are outside of the scope of this paper. Application level interconnection, such as the operation of DNS between providers, is similarly outside of the scope of this paper.

2.2 Overview of Routing in the Internet

Routing in the Internet is generally divided into internal routing and external routing.

Internal routing refers to routing within an Autonomous System (AS), where an AS might be a service provider network, or a contiguous and well-connected part of an ISP network. In most cases either “Intermediate-System to Intermediate-System” (IS-IS) [1] or “Open Shortest Path First” (OSPF) [2] are used as the Internal Gateway Protocol (IGP) within an AS. These protocols provide dynamic routing within a network, and can be used to support certain types of traffic engineering (such as balancing of traffic flows within a network). However, IS-IS and OPSF do not support complex policy-based routing such as is needed between service providers.

Routing between ASs makes use of “Border Gateway Protocol version 4” (BGP) [3]. BGP supports a wide range of administrative, engineering, and architectural policies which may affect choice of routes, and also has been shown through operational experience to scale to support a very large Internet with more than 100,000 routes.

In many cases ISPs use shortest exit routing (also known as "hot potato" routing). With shortest exit routing, a packet which is to be forwarded via a neighboring ISP is sent via the nearest interconnect to that ISP, without concern for where in the neighboring ISP the destination is actually connected. In other words, the packet will use the interconnect closest to the point where the packet enters the first ISP.

Consider two ISPs which span the same geographic area, and which are interconnected in multiple locations. Figure 1 shows an example of two backbone ISPs, which are interconnected in four locations.

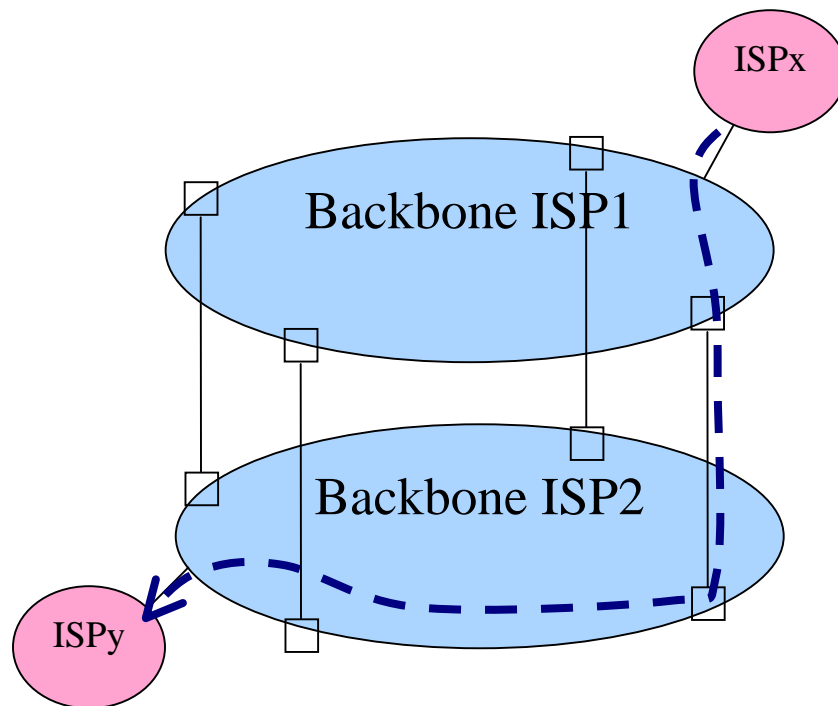

Figure 1: Illustration of Shortest Exit Routing

Consider a packet originating in service provider ISP_x (served by Backbone ISP1), for a destination in service provider ISP_y (served by Backbone ISP2). ISP_x forwards the packet to its backbone service provider, which is ISP1. ISP1 then does a normal route lookup, and finds that the destination is served by Backbone ISP2. ISP1 then forwards the packet to ISP2. With shortest exit routing, ISP1 will use the closest connection to ISP2, as illustrated in figure 1. ISP2 then forwards the packet on to ISP_y.

In this example, the ISP whose customer is originating the packet (ISP1) needs to forward the packet for only a short distance. The ISP whose customer is receiving the packet needs to forward the packet for a greater distance. This is a common occurrence when shortest exit routing is used.

If both ISPs use shortest exit routing, the paths that the packets take will not be the same in both directions, even between the same two end points.

2.3 Asymmetric Traffic Load

A significant percentage of the traffic in the Internet goes between web users (i.e., personal computers and workstations) and web servers. In general the volume of traffic from web user to web server is relatively small (consisting of requests for content), and the volume of traffic from web server to web user is relatively large (consisting of the content itself).

This implies that in many cases a particular user of the Internet may originate an exchange of data, for example by using their personal computer or workstation to query a web server. However, the system which initiates the exchange is typically the source of only a small percentage of the total traffic, while the web server which is offering a service is typically the source of the bulk of the traffic.

Where shortest exit routing is used between ISPs with a similar geographic footprint, this means that the amount of traffic is different in each direction, which may cause one ISP to incur more cost than the other.

In general some ISPs may be primarily offering services to residential customers, others may primarily offer services to web servers, others may primarily offer services to business, while still other ISPs may offer services to a mix of customers. An ISP's customer ratio will have an effect on the symmetry or asymmetry of its traffic flows.

Traffic flows between countries are affected by availability and cost of transport as well as by a host of factors that influence where content is located. For example, flows of data between countries or between continents may be asymmetric due to a relatively higher concentration of web servers in some countries and a relatively lower concentration in other countries. These effects imply that traffic flows may in some cases be highly asymmetric. In many cases where there is asymmetric traffic flow between two countries, the bulk of the traffic may be initiated by requests by users in one country, even though the bulk of the bits are originated in the other country.

2.4 Public versus Private Interconnect

Public interconnection points [such as Metropolitan Area Exchange(MAE)-East, MAE-West and the Ameritech Advanced Data Services (AADS) Network Access Point (NAP)] allow multiple ISPs to interconnect at one physical location. This allows an ISP to provision one circuit to one location, and yet obtain connectivity with multiple ISPs. This is therefore the most efficient means of interconnection when two ISPs have a relatively low amount of traffic to exchange.

In some cases it is possible for two service providers to have so much traffic to exchange that it is more efficient for them to interconnect directly. Typically this requires provisioning direct circuits between providers (which can in some cases be in the same building), and each provider dedicates a router port to the interconnection.

For the interconnection of any two ISPs, there is a tradeoff between the use of more connections versus the use of faster connections to achieve higher bandwidth. As an example, consider two ISPs that span the U.S. If they were to interconnect only on the east coast, then traffic originating at one ISP on the west coast, for a destination at the other ISP on the west coast, would have to traverse each service provider's network in order to reach the interconnection point. It is therefore useful for ISPs with a common geographic range to interconnect at multiple points. However, in general a higher speed connection costs less than multiple lower speed connections. Also, one higher speed

interconnection implies less total network management effort when compared to multiple lower speed interconnections. Therefore the number and location of interconnection points is generally based on economic and other tradeoffs.

2.5 Service Provider Interconnection: Peering and Transit

Interconnection in the Internet is effected in many cases through one of two arrangements: *peering* and *transit*. Note that combinations of these arrangements and more complex arrangements may also be used, as discussed later in this paper.

Peering is an agreement between ISPs to carry traffic for each other and for their respective customers. Peering does not include the obligation to carry traffic to third parties. Peering is usually a bilateral business and technical arrangement, where two providers agree to accept traffic from one another, and from one another's customers (and thus from their customers' customers).

Peering, as used in this document, refers to a relationship between service providers. The term "peer", as used in this context should not be confused with the use of the same term to describe a relationship between two routers. For example, two routers which directly exchange BGP packets are referred to (in other documents) as "BGP Peers".

Transit is an agreement where an ISP agrees to carry traffic on behalf of another ISP or end user. In most cases transit will include an obligation to carry traffic to third parties. Transit is usually a bilateral business and technical arrangement, where one provider (the *transit provider*) agrees to carry traffic to third parties on behalf of another provider or an end user (the *customer*). In most cases, the transit provider carries traffic to and from its other customers, and to and from *every* destination on the Internet, as part of the transit arrangement. In a transit agreement, the ISP often also provides ancillary services, such as Service Level Agreements, installation support, local telecom provisioning, and Network Operations Center (NOC) support.

Peering thus offers a provider access only to a single provider's customers. Transit, by contrast, usually provides access at a predictable price to the entire Internet.

Historically, peering has often been done on a bill-and-keep basis, without cash payments. Peering where there is no explicit exchange of money between parties, and where each party supports part of the cost of the interconnect, may be referred to as *shared-cost peering*. Shared-cost peering is typically used where both parties perceive a roughly equal exchange of value. Peering therefore is fundamentally a barter relationship.

In some cases peering might be desired, but there might be an understanding that the parties would not receive roughly equal value. In such a case *paid peering* may be used. Paid peering is an agreement whereby ISPs agree to carry traffic for each other and for their respective customers, but with some payment involved in order to offset perceived differences in value received and/or cost.

The large number of ISPs worldwide implies that it is not feasible for every ISP to interconnect with every other ISP. Any-to-any interconnection of ten thousand ISPs would require some fifty million connections – which is not technically feasible.

There are significant equipment, circuit and management costs of interconnection. Even in an environment where there is a perception of equal value for a particular interconnection, this value might not be enough to justify the cost of the interconnection. Any given ISP therefore will not choose to peer with every other ISP on a shared-cost basis.

Instead ISPs make conscious decisions as to which providers they will peer with, and under what business terms. In the United States, the decision to peer, or to decline to peer, is driven by competitive market forces, rather than by government regulation. Moreover, there is no legal obligation to disclose these decisions or these terms.

An ISP's criteria for deciding the ISPs with which it will peer are outlined in a peering policy. As noted above, peering is negotiated based on market forces and will result when it is mutually beneficial to two ISPs. Thus, the criteria contained in peering policies are metrics for determining mutuality of benefit.

2.6 Flexible Interconnection

ISPs are at the same time intense competitors but are driven to cooperate and collaborate in order to provide the universal connectivity needed and demanded by their customers. Differences among networks in location, coverage, customer mix, customer size, loyalty of installed base, service offerings, network quality, cost and market structure complicate the mutual assessment of peering versus transit. Typically, ISPs develop interconnection strategies to address two main points: cost and performance.

ISPs may have different peering models due to geographical network footprint or customer base, etc. ISPs tend to peer with ISPs of a similar scale (as this often allows for a perceived rough equality of value). Smaller ISPs may have limited peering with larger ISPs and generally attain connectivity to the global Internet through transit service from their upstream transit provider(s). It may be that a large ISP may purchase transit from another large ISP in order to attain connectivity outside of its own network footprint. For example, a large North American ISP may enter into a transit relationship with another North American ISP because this other ISP also has a network presence in Europe or Asia.

In such a case an ISP may have both a peering relationship and a transit relationship with another ISP. ISP A may peer with ISP B in the United States, for locations in the United States. Simultaneously ISP A may buy transit from ISP B for locations in Europe or Asia. Depending upon the geographic reach of ISP A, and depending upon the business relationships, the actual exchange of routing information and data destined for locations in Europe or Asia might take place either in the US, or overseas. Consider the scenario in which each network maintains or separately contracts for their own inter-continental

links. In this case the two ISPs may only announce the US-based customers to one another in North America. In Europe, ISP B may announce ISP A's European routes to both ISP B customer and peers.

The majority of ISPs purchase transit from other ISPs, even in case of ISPs that have global networks. For example, a global ISP that has a network in the U.S., Europe and Asia may purchase transit from an Asian ISP that has a more expansive Asian network than its own.

ISPs' percentage of connectivity obtained by transit vs. peering may vary greatly depending on the particular interconnection model. Generally speaking, the larger the ISP the larger percentage of its traffic will be transported through peering connections as opposed to transit. This is mainly due to the fact that a larger ISP's network will physically reach more locations, implying that the larger ISPs have the ability to peer in more locations than smaller ISPs.

No single ISP owns a network that reaches all points of the global Internet. Therefore, in some cases ISPs may choose to buy transit from another ISP rather than build a network to reach a specific part of the globe. This is typically due to the opportunity cost of building a network vs. outsourcing (buying transit). This model may apply to the smallest ISP as well as to the largest of global ISPs. An ISP's particular interconnection model therefore will reflect a "buy vs. build" decision: an ISP may either incur the cost of building its own network and thereby position itself to barter for interconnection (i.e., peering), or it can effectively "rent" other ISPs' networks by buying transit.

Interconnection strategies are therefore largely constructed on a case-by-case basis. They reflect the wide variety of business models: wholesale transit vs retail, transport ISPs vs web-centric ISPs, hub ISPs vs backbone ISPs vs access ISPs, commodity vs Quality of Service (QoS) ISPs, Content Distribution Networks (CDN) vs content-peering networks, QoS aggregators, and others.

Different business arrangements have evolved depending on the type of ISP. For example: Two peering transport ISPs with similar traffic profiles may split the costs of bilateral circuit connections. However, in some cases transport ISPs may make use of a different relationship with ISPs specializing in content hosting. ISPs may exchange traffic using a 'longest exit' (as opposed to a 'shortest exit') of traffic that is traveling from the transport ISP to the hosting ISP. The term "cold potato" routing is sometimes used to refer to this form of interconnection. This of course affects which ISP takes on the cost of carrying traffic long-haul, which may in turn affect the payment structure which is agreed between ISPs.

Interconnection strategies also reflect the patterns of industry evolution that have varied in different countries and regions. The pace of telecommunications liberalization, and varying patterns of regional development and international transit costs, have shaped the interconnection in each country and region.

It has been suggested that the complexity evident in actual interconnection agreements imply that it would be difficult or impossible to write a regulation that addresses the rich forms of agreement that exist between providers. There is a wide range of interconnection agreements in place. These exist as efficient market responses that a pair of providers find mutually beneficial.

3. Quality of Interconnections

3.1 Performance and Scalability

The overall Internet service can only be as good as the quality of the interconnection between ISPs. It is important that the interconnection between ISPs scale in terms of bandwidth, number of ISPs interconnected, and for efficient Internet-wide routing and management.

In the past traffic congestion at public interconnection points has been a problem, resulting in traffic loss. This has been improved considerably through migration of public interconnection points to relatively faster network technologies and due to the greater use of private peering.

3.2 Robustness and Security

ISPs' networks are at risk due to a range of hazards, ranging from equipment and link failures, power outages, natural disasters, mis-configuration, and intentional attacks. These intentional attacks include Denial of Service (DoS) and virus attacks. Network attacks such as the Code Red worm are a serious concern to ISPs.

In general, directly connected ISPs will need to cooperate in fault detection. For example, if a customer from one ISP is having trouble interconnecting with a customer of another ISP, then both ISPs may need to get involved in determining whether the problem is within one ISP's network, within the other ISP's network, or at the interconnection point. Similarly ISPs may need to cooperate in management of inter-domain routing between the ISPs.

Due to the interconnected nature of the Internet, it is important that ISPs share information to respond to such attacks. Operational issues relating to DoS attacks and other network security threats may be addressed in organizations that are established for the exchange of information among and between industry participants and government. However, information sharing has legal implications related to the Freedom of Information Act (FOIA) and antitrust laws. Various stakeholders are working to identify and develop the best forum in which ISPs and government can share operational information related to risks and threats from network attacks while maintaining the confidentiality of sensitive information and protecting ISPs from legal liability.

3.3 Tools for Measuring Interconnections

There is a need for tools to measure performance and reliability. Here there is a need to make a distinction between (i) application end to end performance; (ii) IP end to end performance; (iii) performance within an ISP; and (iv) performance at the interconnection point. Optimizing performance at each interconnection point is a small but essential part of optimizing overall performance.

The ability to measure performance, including interconnect performance, is required in order to solve overall performance issues in the Internet. Where any performance problem occurs, there may be many locations which could in principle be the bottleneck causing the problem. It is important to be able to isolate where this bottleneck occurs.

Commonly used measurement tools tend to look at end to end performance, without isolating where the bottleneck is. Additional work is needed to develop better tools for measuring performance and to isolate bottlenecks.

4. Potential Issues

4.1 Publishing Interconnection Guidelines

In the United States, the decision to connect, how to connect, or to decline to connect, is driven by competitive market forces, rather than by government regulation. Because of the competitive nature of these arrangements, there is no legal obligation to disclose these decisions, terms, or to whom one connects. Decisions about which connection arrangement; peering, paid peering, or transit, or a hybrid arrangement, are determined by the competitive conditions of the market. Peering and transit are established pursuant to contracts between the parties. These contracts are usually treated as confidential business information.

However, many would argue that the conditions under which providers are willing to enter into discussions regarding such contracts need not, and perhaps should not, be treated as confidential information.

There are many players in the worldwide Internet, and a common understanding of frequently used practices, processes, and procedures is desirable to foster smooth and efficient operation of processes necessary for the operation of the Internet. In general, when a process is carried out in private, it is difficult for others to fully understand the process. A lack of openness can lead to *perceptions* of lack of fairness in the process, particularly in the absence of competitive options.

Over the past year, several of the largest ISPs in the United States have voluntarily chosen to openly publish the basis on which they decide with whom they will enter into discussions about peering on a shared cost basis. In the opinion of NRIC V, this has been

a positive development, both for U.S. industry and for the global Internet community. It has significantly enhanced transparency of process in the industry.

In publishing peering policies, ISPs seek to:

- Increase transparency of process;
- Increase efficiency of process;
- Demonstrate that U.S. industry practices are neither discriminatory nor exclusionary; and
- Allay concerns of domestic and overseas providers and the public.

For these reasons, NRIC V, Focus Group 4 (FG4) has encouraged service providers, and especially the large "backbone" Internet providers, to consider, consistent with their business practices, publication of their criteria for entering discussions about peering.

Some participants have expressed a concern that the process of publishing peering criteria would itself result in a harshening of peering criteria. Because of the complexity in evaluating the costs and benefits of interconnections, guidelines may fail to capture all relevant market factors. If published guidelines are considered as contractual obligations, ISPs could be tempted to publish unnecessarily harsh guidelines. It is certainly not the intent of FG4 to recommend a policy that would cause a change in peering criteria. Rather, our purpose is to support publishing peering policies as an important part of ensuring efficient operation of the Internet.

This paper does not take a position on the content of the peering requirements posted by any particular ISP. Some ISPs feel that certain peering practices are exclusionary, others do not agree. However, publication of an ISP's peering policies opens these policies to public scrutiny and debate, arguably making unreasonable or exclusionary policies less likely.

4.2 Issues to be Considered

In general it may be necessary for a service provider to limit the number of other networks with which it peers, and/or to ensure that peering arrangements are mutually beneficial and of sufficient value to justify the cost of peering. Internet providers do not and can not peer with all other Internet providers. This is because peering requires expenditure of resources, including human resources, use of equipment, and network bandwidth. Such resources are constrained in most cases. For this reason ISPs make conscious decisions as to with which providers they will peer, and under what business terms. In the United States, the decision to peer, or to decline to peer, is driven by market forces, rather than by government regulation.

For example, peering requires some coordination between ISPs, which in turn implies human resources to perform the coordination. Network management is needed, for example for configuration of BGP policies, and for fault isolation, detection, and correction.

Private peering requires that local circuits be configured (and paid for) between the peering ISPs. Routers must also be provided and configured.

Adding additional peers at public peering points is relatively less expensive for low or moderate bandwidth interconnection. For example, if a new provider wished to peer at a public peering point, then only that one provider will need to provision a circuit to the peering point, other existing providers will already have circuits to that peering point. However, addition of a new peer at a public peering point still requires management of BGP policies. If the aggregate traffic level increases sufficiently, then other providers may need to increase circuit capacity, or the network capacity at the peering point may need to be increased. Also, ISPs who directly exchange a large volume of traffic may find that it is more efficient to use private peering with circuits and routers dedicated to the exchange of data.

There is a potential problem if certain backbone ISPs fail to interconnect either by peering or transit. In principle, this could result in a loss of full connectivity in the Internet. Full connectivity between any two ISPs requires that the two ISPs either peer directly, that one of them obtains transit from the other, or that at least one of them obtains transit service from a third ISP. Up to now this problem has been resolved or avoided by business pressures: Any ISP which fails to offer full internet connectivity will receive considerable pressure from its customers, and up to now this pressure has been sufficient to motivate ISPs to provide full connectivity. Competition will force ISPs to interconnect, either directly or indirectly. ISPs are driven by market forces to have interconnection agreements (whether via shared cost peering, paid peering, or transit service) to serve their end users.

In some cases changes in inter-domain routing may take a while to stabilize in the Internet. For example, there are cases where routing dynamics have taken as long as several minutes to converge. One option for improving convergence times is to limit the path length between any two providers. However, note that reducing all paths to 2 hops would require that all ISPs peer with all other ISPs, which is technically infeasible. There is a trade-off here between convergence time versus the overhead of peering (e.g., number of interconnections and amount of network management needed).

The Internet primarily uses topology-based addressing [4], in which a customer who receives Internet connectivity from a provider also receives its address allocation from that provider. This use of topological addressing is important to limit the growth in the number of prefixes visible in top-level IP routing. This in turn implies that an ISP that does a poor job in aggregating addresses may be straining the entire Internet inter-domain routing system. However, there is in general difficulty in agreeing on the definition of "poor job" and there is also difficulty in agreeing what should be done to address this issue. Also, there are reasons to avoid aggregation in some cases, such as where a customer is attached to multiple service providers ("multi-homing") and to optimize routes to some customers ("traffic engineering"). Thus, there are engineering trade-offs in address aggregation decisions.

4.3 Examples of Criteria

No two networks are exactly the same. However, in order for the Internet to operate, all of the IP service providers worldwide must be interconnected in some fashion. At some level every ISP needs to have a method or criteria to determine which other ISPs it will connect as peers, and which ones should connect as customers.

Each ISP has the right to define its own peering criteria. The goal of this section is not to judge whether these criteria are correct, but rather to provide examples of criteria that may optionally be used, and to educate others on why these criteria exist.

A motivation affecting the design of peering criteria is to ensure a reasonable and fair allocation of cost to each party, and a mutuality of benefit shared between the peering parties. ISPs may want to keep this goal in mind in developing peering criteria, and in evaluating the degree to which these criteria apply in any particular case.

Some ISPs use their peering criteria as guidelines only, and peering criteria may change over time. The amount of flexibility employed when evaluating conformance with peering criteria may also change due, for example, to concerns about regulatory issues. However, it may be undesirable for criteria to be applied too harshly, since interconnection in some form (whether direct or indirect) is needed for full Internet connectivity

4.3.1 Geographic Coverage

One of the most common criteria for peering is similar geographic coverage. The basis for this is that it costs more resources to build a national or global network than it does to build and maintain a regional network. Many ISPs feel that regional and national ISPs should not be considered peers because the national ISP incurs a greater expense to build out its network. As an example, a nationwide network may have to carry its customer traffic an average of 500 route miles, while a regional network may only have to carry the traffic an average of 100 miles. Geographic coverage therefore serves as a measure of whether there would be a reasonably balanced benefit to the two ISPs in entering into a peering relationship.

The relative importance of geographic coverage may change over time. For example, the relative cost of using 1000 miles of fiber along an existing right of way, versus the cost of laying 10 miles of fiber within a congested city, may change with advances in technology. Advances in optical technology may reduce the cost of the former, while advances in wireless technology may provide an alternative to the latter. Relative costs may change based on technological advances which are difficult or impossible to predict.

Geographic coverage may be used to represent costs other than just circuit costs. For example, a geographically limited regional network might operate a single Point of Presence (PoP). A national or international network might have PoPs in many major cities across a wide geographic range.

ISPs with a larger geographic footprint also have a larger potential customer base. This may represent an advantage which offsets the greater cost of maintaining the larger geographic footprint.

4.3.2 Proximity of Exchange Points

In some cases an ISP will require peering connections to be built in specific geographic areas. This serves to reduce the cost of exchanging traffic and is also useful to balance traffic loads. This requirement may in some cases also double as a geographic coverage requirement.

In many cases it is in the best interest of both parties to peer in geographically dispersed locations. Fewer connections cause an increase in the consumption of long-haul bandwidth, and more connections consume more local loops. Both extremes can cause a significant waste of resources. As an example of why the location of peering may be of importance: Two nationwide ISPs connecting only on the east coast will consume significant resources hauling their west coast customer traffic to the east coast.

Some ISPs will modify this requirement to consider geographic differences, such as for peering for some specific routes for ISPs located on different continents. For example some US providers may agree to announce US routes to Asian ISPs (and receive Asian routes) without requiring an east coast peering location, and may announce US routes to European ISPs (and receive European routes) without requiring a west coast peering location.

4.3.3 Minimum Capacity Requirements

The requirement for a specific geographic coverage can sometimes be coupled with the requirement of the peer ISP's backbone being able to maintain a certain link capacity. One reason for this requirement is that it costs more to run a higher capacity backbone. Also, before agreeing to a peering relationship, an ISP wants to ensure that its peer will have sufficient capacity to carry the first ISP's traffic in a manner that satisfies its customers' expectations. In many cases the capacity requirements may vary from region to region with the most restrictive requirements in areas where more capability is typically available and lower requirements in other areas.

4.3.4 Symmetry of Traffic Exchange

Some ISPs require that the traffic exchanged between networks must be roughly balanced in order to peer. For example the traffic sent from one ISP to the other must be comparable to the traffic received. Since most ISPs use shortest exit routing, it usually costs less resources to produce a bit than it does to consume a bit. Thus if one ISP sends significantly more traffic to another ISP than it receives, it probably costs it less to peer. This situation may arise from an ISP focusing on a certain niche market (like hosting, or access).

Note however, that web traffic tends to be highly asymmetric, with the traffic flows from web server to client much greater than flows from client to server. An ISP which supports multiple popular web services will therefore tend to generate more bits of data than one which supports primarily home users or other web customers. Also where ISPs have highly different geographic coverage, the asymmetric cost of carrying traffic might be more balanced. The reasons for asymmetry in IP traffic may therefore need to be taken into consideration in some cases.

4.3.5 Minimum Traffic Loads

Most private peering guidelines have a minimum traffic load requirement. This tends to go hand-in-hand with private peering, since for small or moderate traffic loads it costs more to establish a direct peering connection than to add another peer at a public peering site. The goal of these requirements is to make sure that there will be enough value in the exchange of traffic to warrant the cost of interconnection, including the peering circuit as well as equipment and network management costs.

4.3.6 Reliable Network Support

Almost all ISPs require that a peer have a 24x7 NOC. The Internet has not evolved to the point where every ISP can completely protect themselves from accidental or malicious acts by their peers or from attacks launched through a peer. The requirement of a 24x7 NOC ensures that if something does happen it can be rectified quickly. The requirement to enable loose source routing of packets is sometimes included to enable the operators and engineers of that network to be able to track the return path of their traffic. In principle ISPs might also make some requirement with respect to the experience level or capabilities of their peers, although this could be difficult to quantify.

4.3.7 Reasonable Address Aggregation

The efficiency of overall inter-domain routing in the Internet requires that some care be used in the assignment of addresses (in order to limit the size of the overall Internet routing tables). However, note that a core ISP which does a good job of address allocation is aiding its peers more than it is helping itself – each ISP has to maintain separate routes to its own customers in its internal routing, regardless of whether it can aggregate these routes for advertisement to other ISPs.

An ISP might therefore require reasonable address aggregation as a criteria for peering. Alternatively, an ISP might limit which routes it is willing to accept from its peers.

5. Summary

This white paper deals with interconnection between Internet Service Providers (ISPs). The report describes the various interconnection arrangements which are presently in use

in the Internet, and identifies some areas that affect interoperability and reliability. It is noted that there is a wide range of interconnection agreements in place, which exist as efficient market responses to the requirements of maintaining the operational Internet. The white paper also lists some of the issues that ISPs take into consideration when they decide what type of interconnection is appropriate with other ISPs and notes that the Internet is evolving continuously in a manner that is constrained by market forces and technical feasibility. This report is limited to best effort Internet Protocol (IP) services.

The white paper notes that interconnection strategies also reflect the patterns of industry evolution that have varied in different countries and regions and notes that the pace of telecommunications liberalization, and varying patterns of regional development and international transit costs, have shaped the interconnection in each country and region.

The white paper concludes by encouraging ISPs, and especially the large "backbone" ISPs, to consider, consistent with their business practices, publication of their criteria for entering discussions about peering. Publishing peering policies will increase the transparency and the efficiency of the process, demonstrate that U.S. industry practices are neither discriminatory nor exclusionary, and allay concerns of domestic and overseas providers and the public.

6. References

RFCs

- [1] Ross Callon, "Use of OSI IS-IS for Routing in TCP/IP and Dual Environments", RFC 1195, Dec 1990.
- [2] John Moy, "OSPF Version 2", RFC 2328, April 1998.
- [3] Yakov Rekhter and Tony Li, "A Border Gateway Protocol 4 (BGP-4)", RFC 1771, March 1995.
- [4] Yakov Rekhter and Tony Li, "An Architecture for IP Address Allocation with CIDR", RFC 1518, September 1993.

ACADEMIC PAPERS/BOOKS

- [5] S. Butler, The Evolution of Internet Interconnections, Capstone Project, M.S. in Information Technologies, Rochester Institute of Technology, 8/00
- [6] J. Cremer, P. Rey, and J. Tirole, Connectivity in the Commercial Internet, Toulouse, Institut economie industrielle, 1999, presented at "Competition and Innovation in the Personal Computer Industry", San Diego, April, 1999.
- [7] Jean-Jacques Laffont, J. Scott Marcus, Patrick Rey and Jean Tirole,

- "Internet Interconnection", American Economic Review, Vol. 91, No. 2, May 2001.
- [8] Jean-Jacques Laffont and Jean Tirole, Competition in Telecommunications, MIT Press, 2000.
- [9] K. Cukier, Peering and Fearing: ISP Interconnection and Regulatory Issues, <http://www.ksg.harvard.edu/iip/iicompol/Papers/Cukier.html>
- [10] P. Reichl, S. Leinen, and B. Stiller, A Practical Review of Pricing and Cost Recovery for Internet Services, IEW '99, 2nd Internet Economics Workshop, Berlin, Germany, May 28-29, 1999, <http://www.tik.ee.ethz.ch/~cati/paper/iew99.pdf>

INDUSTRY PAPERS

- [11] G. Huston, ISP Survival Guide
- [12] G. Huston, Interconnection, Peering and Settlements—Part I, The Internet Protocol Journal, Volume 2, Number 1, 3/99, Cisco Systems http://www.cisco.com/warp/public/759/ipj_2-1/ipj_2-1_ps1.html
- [13] G. Huston, Interconnection, Peering and Settlements—Part II, The Internet Protocol Journal, Volume 2, Number 2, 6/99, Cisco Systems, http://www.cisco.com/warp/public/759/ipj_2-2/ipj_2-2_ps1.html
- [14] B. Norton, Internet Service Providers and Peering, <http://www.nanog.org/mtg-0006/norton.doc>
- [15] B. Norton, Peering Decision Tree, <http://www.nanog.org/mtg-9910/ppt/peering/tree.doc>
- [16] J. Scott Marcus, "Designing Wide Area Networks and Internetworks: A Practical Guide", particularly Chapter 14 "The Public Internet, Unique Design Considerations", Addison Wesley Longman, 1999.

NEWS ARTICLES

- [17] Randy Barrett, ISP Survival Guide: Peering into the Future, Inter@ctive Week Online, ZDNet, 12/7/98, <http://www.zdnet.com/intweek/supplements/survival/peering.html>

GOVERNMENT PUBLICATIONS

- [18] Australian Competition and Consumer Commission (ACCC), Internet

Interconnection: Factors Affecting Commercial Arrangements between Network Operators in Australia, 2/17/00, <http://www.accc.gov.au/telco/fs-telecom.htm>

- [19] European Commission, Directorate-General Information Society, Internet Network Issues, 9/14/01
- [20] M. Kende, The Digital Handshake: Connecting Internet Backbones, Office of Plans and Policy, FCC, OPP Working Paper No. 32, 9/00, http://www.fcc.gov/Bureaus/OPP/working_papers/oppwp32.pdf
- [21] Committee on the Internet in the Evolving Information Infrastructure, Computer Science and Telecommunications Board, Commission on Physical Sciences, Mathematics, and Applications, National Research Council, The Internet's Coming of Age, 2001

INTERNATIONAL ORGANIZATIONS' PAPERS

- [22] OECD, Internet Traffic Exchange, Policy and Development, 1998
OECD, Workshop on Internet Traffic Exchange, Berlin, Germany, June 7-8, 2001, <http://www.oecd.org/dsti/sti/it/cm/index.htm>, e.g., see G Huston (Telstra) "The Changing Structure of the Internet", and Jean Claude Geha (Telia) "Next Generation Traffic Exchange".

INTERCONNECTION GUIDELINES

- [23] Genuity, <http://www.genuity.com/infrastructure/interconnection.htm>
- [24] Level3, <http://www.level3.com/us/services/crossroads/policy>
- [25] WorldCom, www.worldcom.com/peering

OTHER

- [26] Albert, Jeong, and Barabasi, "Error and Attack Tolerance of Complex Networks", Nature, July 27, 2000.
- [27] Lixin Gao, "On Inferring Autonomous System Relationships in the Internet", Proceedings of IEEE GlobeCom 2000, San Francisco, November, 2000.