

1
2
3
4
5
6
7
8
9
10
11
12
13
14
15
16
17
18
19
20
21
22
23
24
25
26
27
28

UNITED STATES DISTRICT COURT
NORTHERN DISTRICT OF CALIFORNIA

SIMPSON STRONG-TIE COMPANY,
INC,

Plaintiff,

v.

OZ-POST INTERNATIONAL, LLC,

Defendant.

Case No. [3:18-cv-01188-WHO](#)

**ORDER ON MOTION TO COMPEL
SUPPLEMENTAL INFRINGEMENT
CONTENTIONS**

Re: Dkt. No. 59

INTRODUCTION

This case involves a patent dispute between competitors Simpson Strong-Tie Company, Inc. (“Simpson”) and Oz-Post International LLC dba OZCO Building Products (“OZCO”). The pending motion requires me to decide whether OZCO has produced infringement contentions that comply with the Northern District of California’s Patent Local Rules. OZCO did produce adequate infringement contentions—but only after the instant motion was filed, and only informally. Accordingly, I will grant Simpson’s motion and order OZCO to formally produce its latest round of contentions.

BACKGROUND

Both Simpson and OZCO design and manufacture connectors and anchors for the construction industry. Second Amended Complaint (“SAC”) ¶ 3; Answer to SAC (“Answer”) [Dkt. No. 53] ¶ 48. OZCO is the sole assignee of the two patents at issue in this case: United States Patent Numbers 9,957,998 (“the ’998 Patent”) and D798,701 (“the ’701 Patent”).

In February 2017 and January 2018, OZCO sent demand letters asserting that Simpson’s structural screw and hex-head washer installation (“the Accused Instrumentality”) infringed the

1 '701 Patent.¹ On February 23, 2018, Simpson filed this action, seeking declaratory judgment of
2 noninfringement along with an order declaring the '701 Patent invalid. Complaint [Dkt. No. 1].
3 On May 18, 2018, Simpson amended its complaint to add a false advertising claim, First Amended
4 Complaint [Dkt. No. 22], and on August 31, 2018, it amended to add the '998 Patent.² Second
5 Amended Complaint (“SAC”) [Dkt. No. 52].

6 OZCO first served infringement contentions on September 25, 2018. Motion to Compel
7 (“Mot. to Compel”) Ex. A (Defendant’s Asserted Claims and Infringement Contentions) [Dkt. No.
8 59-1] ECF pages 4–18. By letter dated October 5, Simpson informed OZCO that its contentions
9 failed to comply with Patent Local Rule 3-1(c) because they compared the Accused
10 Instrumentality to only one figure from the '701 Patent, which includes five figures. Mot. to
11 Compel Ex. G, ECF pages 108–10. OZCO then filed first supplemental infringement contentions
12 on October 12. Mot. to Compel Ex. H, ECF pages 111–19. On October 17, Simpson wrote a
13 letter asserting that these contentions were also deficient. Mot. to Compel Ex. I, ECF pages 120–
14 22. While the contentions incorporated all five images from the '701 Patent, they made
15 comparisons not with the Accused Instrumentality but with a different patent assigned to Simpson.
16 *Id.* By letter dated October 24, OZCO expressed its view that its contentions fully complied with
17 Patent Local Rule 3-1(c) because Simpson had held the design patent out as “very similar to the
18 Accused Products” in a prior filing in this case.³ Mot. to Compel Ex. J, ECF pages 123–25
19 (internal quotation marks omitted).

20 On November 19, 2018, Simpson filed this motion to compel, at which point OZCO
21 “informally provided a draft second supplemental claim chart.” Opposition to Mot. to Compel
22 (“Oppo.”) [Dkt. No. 69] 3. This chart compares each of the '701 images to illustrations of the
23

24 ¹ The '998 Patent did not issue until May 1, 2018. Answer ¶ 15.

25 ² On May 1, 2018 (the day the '998 Patent issued), OZCO filed a complaint in the Eastern District
26 of Texas alleging infringement of both the '701 and '998 Patents. Answer ¶ 15. After I denied
27 OZCO’s motion to transfer this case to that district, Dkt. No. 47, OZCO voluntarily dismissed that
28 action without prejudice. Answer ¶ 15.

³ Simpson made this representation in its opposition to OZCO’s motion to transfer. Opposition to
Motion to Transfer [Dkt. No. 39] 3.

1 Accused Instrumentality. Oppo. Ex. A. Simpson argues that these contentions remain deficient.
2 Reply [Dkt. No. 70] 2–5.

3 **LEGAL STANDARD**

4 “Patent Local Rule 3 requires patent disclosures early in a case and streamlines discovery
5 by replacing the series of interrogatories that parties would likely have propounded without it.”
6 *ASUS Computer Int’l v. Round Rock Research, LLC*, No. 12-cv-02099-JST, 2014 WL 1463609, at
7 *1 (N.D. Cal. Apr. 11, 2014) (internal quotation marks and modifications omitted). The
8 disclosures required under Rule 3 are designed “to require parties to crystallize their theories of
9 the case early in the litigation and to adhere to those theories once they have been disclosed.”
10 *Nova Measuring Instruments Ltd. v. Nanometrics, Inc.*, 417 F. Supp. 2d 1121, 1123 (N.D. Cal.
11 2006). “They are also designed to provide structure to discovery and to enable the parties to move
12 efficiently toward claim construction and the eventual resolution of their dispute.” *Golden Bridge*
13 *Tech. Inc v. Apple, Inc.*, No. 12-cv-04882-PSG, 2014 WL 1928977, at *3 (N.D. Cal. May 14,
14 2014) (internal quotation marks omitted); *see also O2 Micro Int’l Ltd. v. Monolithic Power Sys.,*
15 *Inc.*, 467 F.3d 1355, 1365-66 (Fed. Cir. 2006) (“The local patent rules in the Northern District of
16 California [require] both the plaintiff and the defendant in patent cases to provide early notice of
17 their infringement and invalidity contentions, and to proceed with diligence in amending those
18 contentions when new information comes to light in the course of discovery.”).

19 Patent Local Rule 3-1 requires a party claiming patent infringement to serve infringement
20 contentions within 14 days of the initial case management conference. Patent L.R. 3-1. Among
21 other requirements, the contentions must include:

22 A chart identifying specifically where and how each limitation of each
23 asserted claim is found within each Accused Instrumentality,
24 including for each limitation that such party contends is governed by
25 35 U.S.C. § 112(6), the identity of the structure(s), act(s), or
material(s) in the Accused Instrumentality that performs the claimed
function.

26 Patent L.R. 3-1(c). Rule 3-1 does not “require a plaintiff to prove its infringement case.” *Tech.*
27 *Licensing Corp. v. Grass Valley USA, Inc.*, No. 12-cv-06060-PSG, 2014 WL 3752108, at *2 (N.D.
28 Cal. July 30, 2014) (internal quotation marks omitted). But “all courts agree that the degree of

1 specificity under [Rule 3-1] must be sufficient to provide reasonable notice to the defendant why
2 the plaintiff believes it has a reasonable chance of proving infringement,” and to “raise a
3 reasonable inference that all accused products infringe.” *Shared Memory Graphics LLC v. Apple,*
4 *Inc.*, 812 F. Supp. 2d 1022, 1025 (N.D. Cal. 2010) (internal quotation marks omitted).

5 **DISCUSSION**

6 **I. THE INITIAL AND FIRST SUPPLEMENTAL INFRINGEMENT CONTENTIONS**

7 Simpson asserts that OZCO’s initial and first amended infringement contentions fail to
8 comply with the Patent Local Rules because they do not “show specifically where and how OZCO
9 alleges each Accused Instrumentality allegedly reads on Figures 1 through 5 of the ’701 Patent.”
10 Mot. to Compel 2. OZCO generally counters that Simpson must have reasonable notice of its
11 infringement allegations based on the fact that it filed this declaratory judgment action and that it
12 accurately characterized OZCO’s theory of infringement in the motion to compel. Oppo. 5.
13 Contrary to OZCO’s arguments, neither its initial nor its first supplemental infringement
14 contentions were adequate.

15 OZCO’s initial infringement contentions only compare the Accused Instrumentality to one
16 image from the ’701 Patent rather than all five. *See* Mot. to Compel 8; *id.* Ex. A, ECF pages 4–18.
17 They also show the Accused Instrumentality as installed, which obscures from view its distinct
18 features, namely the extending tube and screw. Mot. to Compel 7; Reply 1. In response OZCO
19 argues, “It is reasonable to assume that, for claim chart purposes, Simpson could extrapolate the
20 comparisons to the top, bottom, and side views.” Oppo. 5. But the Patent Local Rules require
21 OZCO to make contentions that “crystallize [its] theories” of infringement; it is not Simpson’s
22 burden to extrapolate from limited information OZCO deems appropriate to produce. *See Nova,*
23 *417 F. Supp. 2d at 1123.*

24 OZCO’s first supplemental infringement contentions are inadequate because they compare
25 the images from the ’701 Patent with one of Simpson’s patents rather than the Accused
26 Instrumentality itself. Mot. to Compel 10–12; *id.* Ex. H, ECF pages 111–19. OZCO argues that
27 Simpson made reference to the patent as “very similar” to the Accused Instrumentality. Oppo. 5.
28 Similarity is insufficient to comply with the Patent Local Rules; these contentions fail to meet the

1 mark.

2 **II. THE SECOND SUPPLEMENTAL INFRINGEMENT CONTENTIONS**

3 OZCO informally produced second supplement infringement contentions after Simpson
4 filed the instant motion. Two excerpts from the chart are shown below.

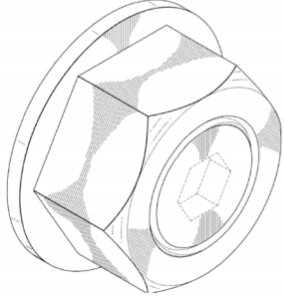
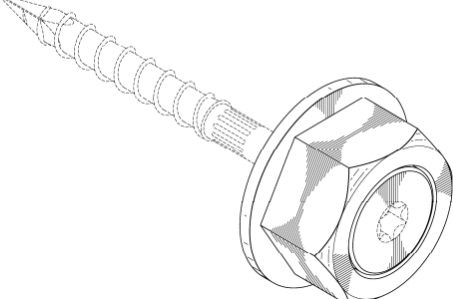
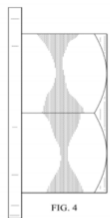
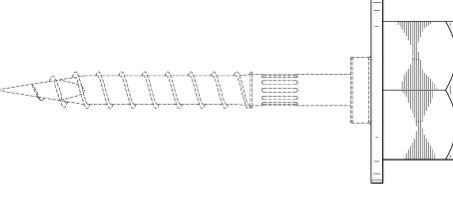
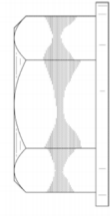
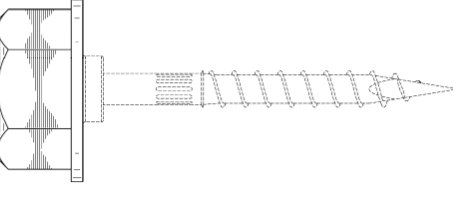
Claim	Accused Instrumentality
1. The ornamental design for simulated bolted hardware, as shown and described.	The Accused Instrumentality is simulated bolted hardware. The ornamental design of the Accused Instrumentality is shown in solid lines below. The broken lines shown in the figures below illustrate nonornamental features of the Accused Instrumentality.
	
 <p>FIG. 4</p>	
 <p>FIG. 5</p>	

21 In its reply, Simpson argues that these contentions are also inadequate. First, OZCO
22 produced illustrations rather than photographs. Reply 5. Second, the illustrations show certain
23 features⁴ with broken lines, which “appears to be an effort to turn the ordinary observer test on its
24 head” because those dissimilar features must remain part of the infringement inquiry. Reply 6–7;
25 *see Ethicon Endo-Surgery, Inc. v. Covidien, Inc.*, 796 F.3d 1312, 1335 (Fed. Cir. 2015) (noting
26 that where there are several elements in the claimed design, “the fact finder must apply the

28 ⁴ OZCO asserts that these features are “nonornamental.” Oppo. 3.

1 ordinary observer test by comparing similarities in overall designs, not similarities of ornamental
2 features in isolation”). Simpson argues that the elements shown with broken lines—the extending
3 tube and screw—“render [the Accused Instrumentality] plainly dissimilar from the claimed
4 design.” Reply 6.

5 Simpson’s arguments about the second supplemental contentions go more to the merits of
6 this patent infringement case than to the adequacy of the contentions themselves. Simpson
7 acknowledges that “[p]hotographs of the Accused Instrumentality compared to each of the five
8 figures of the ’701 Patent would satisfy Rule 3-1(c).” Reply 5. It does not assert that the
9 illustrations are somehow inaccurate representations of its product. Whether the lines are broken
10 or solid and whether the images are illustrations or photographs, these contentions give Simpson
11 reasonable notice of OZCO’s theory of infringement such that it can mount a defense. While
12 Simpson’s dissimilarity arguments could make this claim ripe for summary judgment, they are
13 appropriately addressed only at that stage, not now. *See Shared Memory*, 812 F. Supp. 2d at 1025
14 (noting that the infringement contentions had given defendants reasonable notice, and their
15 remaining arguments “could well set up an early motion for summary judgment or partial
16 summary adjudication on affected claims”).

17 **CONCLUSION**

18 Given that OZCO only informally produced the second supplemental contentions,
19 Simpson’s motion is GRANTED. OZCO is ordered to formally produce its second supplemental
20 infringement contentions within five (5) days of the date of this Order. The January 16, 2019
21 hearing on this motion is VACATED.

22 **IT IS SO ORDERED.**

23 Dated: January 10, 2019

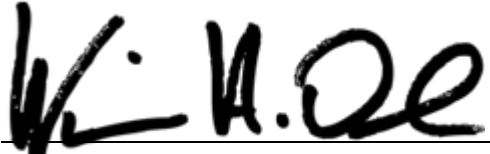
24 
25 _____
26 William H. Orrick
27 United States District Judge
28