

Exhibit K

EXHIBIT L

**SUBJECT TO PROTECTIVE ORDER
CONTAINS HIGHLY CONFIDENTIAL – ATTORNEYS’ EYES ONLY INFORMATION**

**CORRECTED EXPERT REPORT OF DR. BRIAN VON HERZEN ON THE
INVALIDITY OF U.S. PATENTS 7,663,607 AND 7,920,129**

Apple, Inc., vs. Samsung Electronics Co., Ltd., et al.

Case No. 11-cv-01846-LHK

April 5, 2012

TABLE OF CONTENTS

	<u>Page</u>
I. INTRODUCTION	1
II. PROFESSIONAL BACKGROUND.....	1
III. MATERIALS CONSIDERED FOR THIS REPORT	2
IV. APPLICABLE LEGAL PRINCIPLES	2
A. Claim Construction.....	3
B. Anticipation	3
C. Obviousness.....	4
D. Indefiniteness.....	5
E. Conception and Reduction to Practice	6
F. Priority Date	6
G. Derivation	7
H. Inequitable Conduct.....	7
V. PERSON OF ORDINARY SKILL IN THE ART	8
VI. SUMMARY OF OPINIONS OF INVALIDITY OF THE ‘607 PATENT.....	9
A. The Initial Determination of the International Trade Commission Found the ‘607 Patent Invalid on Two Separate Grounds.....	9
B. The Priority Date of the ‘607 Patent.....	11
C. The ‘607 Patent is Invalid due to Anticipation and/or Obviousness.	12
VII. TECHNICAL BACKGROUND PERTINENT TO THE ‘607 PATENT.....	13
VIII. OVERVIEW OF THE 607 PATENT AND THE ASSERTED CLAIMS	22
B. The Specification.....	22
C. The Asserted Claims.....	24
D. The Prosecution History	25

SUBJECT TO PROTECTIVE ORDER
CONTAINS HIGHLY CONFIDENTIAL – ATTORNEYS’ EYES ONLY INFORMATION

IX.	DISPUTED TERMS FROM THE ASSERTED CLAIMS AND THE PARTIES’ PROPOSED CONSTRUCTIONS.....	26
X.	PRIOR ART WHICH INVALIDATES THE ASSERTED CLAIMS OF THE 607 PATENT.....	26
A.	Perski ‘455 Anticipates and/or Renders Obvious the Asserted Claims of the ‘607 Patent.....	27
2.	Analysis of the Claim Elements	28
(a)	Claim [1A] - “A touch panel comprising a transparent capacitive sensing medium configured to detect multiple touches or near touches that occur at a same time and at distinct locations in a plane of the touch panel and to produce distinct signals representative of a location of the touches on the plane of the touch panel for each of the multiple touches”.....	28
(b)	Claim [1B] - “wherein the transparent capacitive sensing medium comprises: a first layer having a plurality of transparent first conductive lines that are electrically isolated from one another”	29
(c)	Claim [1C] – “and a second layer spatially separated from the first layer and having a plurality of transparent second conductive lines that are electrically isolated from one another”	30
(d)	Claim [1D] – “the second conductive lines being positioned transverse to the first conductive lines”.....	30
(e)	Claim [1E] – “ the intersection of transverse lines being positioned at different locations in the plane of the touch panel, each of the second conductive lines being operatively coupled to capacitive monitoring circuitry”	31
(f)	Claim [1F] - “wherein the capacitive monitoring circuitry is configured to detect changes in the charge coupling between the first conductive lines and the second conductive lines”	32
(g)	Claim [2] - “The touch panel as recited in claim 1 wherein the conductive lines on each of the layers are substantially parallel to one another”.....	33

SUBJECT TO PROTECTIVE ORDER
CONTAINS HIGHLY CONFIDENTIAL – ATTORNEYS’ EYES ONLY INFORMATION

(h)	Claim [3] - “The touch panel as recited in claim 2 wherein the conductive lines on different layers are substantially perpendicular to each other”	33
(i)	Claim [6] - “The touch panel recited in claim 1 wherein the conductive lines are formed from indium tin oxide (ITO)”	33
(j)	Claim [7] - “The touch panel as recited in claim 1, wherein the capacitive sensing medium is a mutual capacitance sensing medium”	34
(k)	Claim [8] -- “The touch panel as recited in claim 7, further comprising a virtual ground charge amplifier coupled to the touch panel for detecting the touches on the touch panel”	36
(l)	Claim [10A] – “A display arrangement having a screen for displaying a graphical user interface”	38
(m)	Claim [10B] -- “a transparent touch panel allowing the screen to be viewed therethrough and capable of recognizing multiple touch events that occur at different locations on the touch panel at a same time and to output this information to a host device to form a pixilated image”	38
(n)	Claim [10C] – “wherein the touch panel includes a multipoint sensing arrangement configured to simultaneously detect and monitor the touch events and a change in capacitive coupling associated with those touch events at distinct points across the touch panel”	39
(o)	Claim 10[D] – “wherein the touch panel comprises: a first glass member disposed over the screen of the display;	40
(p)	Claim [10E] – “a first transparent conductive layer disposed over the first glass member”	41
(q)	Claim [10F] – “the first transparent conductive layer comprising a plurality of spaced apart parallel lines having the same pitch and linewidths”	41
(r)	Claim [10G] – “a second glass member disposed over the first transparent conductive layer”	42
(s)	Claim [10H] – “a second transparent conductive layer disposed over the second glass member	42

SUBJECT TO PROTECTIVE ORDER
CONTAINS HIGHLY CONFIDENTIAL – ATTORNEYS’ EYES ONLY INFORMATION

(t)	Claim [10I] – “the second transparent conductive member comprising a plurality of spaced apart parallel lines having the same pitch and linewidths”	43
(u)	Claim [10J] – “the parallel lines of the second transparent conductive layer being substantially perpendicular to the parallel lines of the first transparent conductive layer”	43
(v)	Claim [10K] -- “a third glass member disposed over the second conductive layer”	43
(w)	Claim [10L] – “one or more sensor integrated circuits operatively coupled to the lines”	44
(x)	Claim [11] – “The display arrangement as recited in claim 10 further including dummy features disposed in the space between the parallel lines, the dummy features optically improving the visual appearance of the touch screen by more closely matching the optical index of the lines”	44
3.	The ‘607 Patent is Invalid in View of Perski ‘455	46
B.	Rekimoto Anticipates and/or Renders Obvious the Asserted Claims of the ‘607 Patent	46
2.	Analysis of the Claim Elements	47
(a)	Claim [1A] - “A touch panel comprising a transparent capacitive sensing medium configured to detect multiple touches or near touches that occur at a same time and at distinct locations in a plane of the touch panel and to produce distinct signals representative of a location of the touches on the plane of the touch panel for each of the multiple touches”	47
(b)	Claim [1B] - “wherein the transparent capacitive sensing medium comprises: a first layer having a plurality of transparent first conductive lines that are electrically isolated from one another”	48
(c)	Claim [1C] – “and a second layer spatially separated from the first layer and having a plurality of transparent second conductive lines that are electrically isolated from one another”	49
(d)	Claim [1D] – “the second conductive lines being positioned transverse to the first conductive lines”	49

SUBJECT TO PROTECTIVE ORDER
CONTAINS HIGHLY CONFIDENTIAL – ATTORNEYS’ EYES ONLY INFORMATION

(e)	Claim [1E] – “ the intersection of transverse lines being positioned at different locations in the plane of the touch panel, each of the second conductive lines being operatively coupled to capacitive monitoring circuitry”	50
(f)	Claim [1F] - “wherein the capacitive monitoring circuitry is configured to detect changes in the charge coupling between the first conductive lines and the second conductive lines”	50
(g)	Claim [2] - “The touch panel as recited in claim 1 wherein the conductive lines on each of the layers are substantially parallel to one another”	51
(h)	Claim [3] - “The touch panel as recited in claim 2 wherein the conductive lines on different layers are substantially perpendicular to each other”	51
(i)	Claim [6] - “The touch panel recited in claim 1 wherein the conductive lines are formed from indium tin oxide (ITO)”	52
(j)	Claim [7] - “The touch panel as recited in claim 1, wherein the capacitive sensing medium is a mutual capacitance sensing medium”	52
(k)	Claim [8] -- “The touch panel as recited in claim 7, further comprising a virtual ground charge amplifier coupled to the touch panel for detecting the touches on the touch panel”	53
(l)	Claim [10A] – “A display arrangement having a screen for displaying a graphical user interface”	55
(m)	Claim [10B] -- “a transparent touch panel allowing the screen to be viewed therethrough and capable of recognizing multiple touch events that occur at different locations on the touch panel at a same time and to output this information to a host device to form a pixilated image”	55
(n)	Claim [10C] – “wherein the touch panel includes a multipoint sensing arrangement configured to simultaneously detect and monitor the touch events and a change in capacitive coupling associated with those touch events at distinct points across the touch panel”	56
(o)	Claim 10[D] – “wherein the touch panel comprises: a first glass member disposed over the screen of the display;	56

SUBJECT TO PROTECTIVE ORDER
CONTAINS HIGHLY CONFIDENTIAL – ATTORNEYS’ EYES ONLY INFORMATION

(p)	Claim [10E] – “a first transparent conductive layer disposed over the first glass member”	58
(q)	Claim [10F] – “the first transparent conductive layer comprising a plurality of spaced apart parallel lines having the same pitch and linewidths”	58
(r)	Claim [10G] – “a second glass member disposed over the first transparent conductive layer”	58
(s)	Claim [10H] – “a second transparent conductive layer disposed over the second glass member	59
(t)	Claim [10I] – “the second transparent conductive member comprising a plurality of spaced apart parallel lines having the same pitch and linewidths”	59
(u)	Claim [10J] – “the parallel lines of the second transparent conductive layer being substantially perpendicular to the parallel lines of the first transparent conductive layer”	60
(v)	Claim [10K] -- “a third glass member disposed over the second conductive layer”	60
(w)	Claim [10L] – “one or more sensor integrated circuits operatively coupled to the lines”	61
(x)	Claim [11] – “The display arrangement as recited in claim 10 further including dummy features disposed in the space between the parallel lines, the dummy features optically improving the visual appearance of the touch screen by more closely matching the optical index of the lines”	62
3.	The ‘607 Patent is Invalid in View of Rekimoto	62
C.	Smartskin Anticipates and/or Renders Obvious the Asserted Claims of the ‘607 Patent	63
2.	Analysis of the Claim Elements	63
(a)	Claim [1A] - “A touch panel comprising a transparent capacitive sensing medium configured to detect multiple touches or near touches that occur at a same time and at distinct locations in a plane of the touch panel and to produce distinct signals representative of a location of the touches on the plane of the touch panel for each of the multiple touches”	63

SUBJECT TO PROTECTIVE ORDER
CONTAINS HIGHLY CONFIDENTIAL – ATTORNEYS’ EYES ONLY INFORMATION

(b)	Claim [1B] - “wherein the transparent capacitive sensing medium comprises: a first layer having a plurality of transparent first conductive lines that are electrically isolated from one another”	66
(c)	Claim [1C] – “and a second layer spatially separated from the first layer and having a plurality of transparent second conductive lines that are electrically isolated from one another”	66
(d)	Claim [1D] – “the second conductive lines being positioned transverse to the first conductive lines”	67
(e)	Claim [1E] – “the intersection of transverse lines being positioned at different locations in the plane of the touch panel, each of the second conductive lines being operatively coupled to capacitive monitoring circuitry”	67
(f)	Claim [1F] - “wherein the capacitive monitoring circuitry is configured to detect changes in the charge coupling between the first conductive lines and the second conductive lines”	68
(g)	Claim [2] - “The touch panel as recited in claim 1 wherein the conductive lines on each of the layers are substantially parallel to one another”	68
(h)	Claim [3] - “The touch panel as recited in claim 2 wherein the conductive lines on different layers are substantially perpendicular to each other”	68
(i)	Claim [6] - “The touch panel recited in claim 1 wherein the conductive lines are formed from indium tin oxide (ITO)”	69
(j)	Claim [7] - “The touch panel as recited in claim 1, wherein the capacitive sensing medium is a mutual capacitance sensing medium”	69
(k)	Claim [8] -- “The touch panel as recited in claim 7, further comprising a virtual ground charge amplifier coupled to the touch panel for detecting the touches on the touch panel”	70
(l)	Claim [10A] – “A display arrangement having a screen for displaying a graphical user interface”	70
(m)	Claim [10B] -- “a transparent touch panel allowing the screen to be viewed therethrough and capable of recognizing multiple touch events that occur at different	

SUBJECT TO PROTECTIVE ORDER
CONTAINS HIGHLY CONFIDENTIAL – ATTORNEYS’ EYES ONLY INFORMATION

	locations on the touch panel at a same time and to output this information to a host device to form a pixilated image”	70
(n)	Claim [10C] – “wherein the touch panel includes a multipoint sensing arrangement configured to simultaneously detect and monitor the touch events and a change in capacitive coupling associated with those touch events at distinct points across the touch panel”	71
(o)	Claim 10[D] – “wherein the touch panel comprises: a first glass member disposed over the screen of the display;	71
(p)	Claim [10E] – “a first transparent conductive layer disposed over the first glass member”	73
(q)	Claim [10F] – “the first transparent conductive layer comprising a plurality of spaced apart parallel lines having the same pitch and linewidths”	73
(r)	Claim [10G] – “a second glass member disposed over the first transparent conductive layer”	73
(s)	Claim [10H] – “a second transparent conductive layer disposed over the second glass member	75
(t)	Claim [10I] – “the second transparent conductive member comprising a plurality of spaced apart parallel lines having the same pitch and linewidths”	75
(u)	Claim [10J] – “the parallel lines of the second transparent conductive layer being substantially perpendicular to the parallel lines of the first transparent conductive layer”	75
(v)	Claim [10K] -- “a third glass member disposed over the second conductive layer”	75
(w)	Claim [10L] – “one or more sensor integrated circuits operatively coupled to the lines”	76
(x)	Claim [11] – “The display arrangement as recited in claim 10 further including dummy features disposed in the space between the parallel lines, the dummy features optically improving the visual appearance of the touch screen by more closely matching the optical index of the lines”	77
3.	The ‘607 Patent is Invalid in View of Smartskin	78

SUBJECT TO PROTECTIVE ORDER
CONTAINS HIGHLY CONFIDENTIAL – ATTORNEYS’ EYES ONLY INFORMATION

D.	Mulligan Anticipates and/or Renders Obvious the Asserted Claims of the ‘607 Patent.....	78
2.	Analysis of the Claim Elements	78
(a)	Claim [1A] - “A touch panel comprising a transparent capacitive sensing medium configured to detect multiple touches or near touches that occur at a same time and at distinct locations in a plane of the touch panel and to produce distinct signals representative of a location of the touches on the plane of the touch panel for each of the multiple touches”	78
(b)	Claim [1B] - “wherein the transparent capacitive sensing medium comprises: a first layer having a plurality of transparent first conductive lines that are electrically isolated from one another”	80
(c)	Claim [1C] – “and a second layer spatially separated from the first layer and having a plurality of transparent second conductive lines that are electrically isolated from one another”	82
(d)	Claim [1D] – “the second conductive lines being positioned transverse to the first conductive lines”.....	83
(e)	Claim [1E] – “ the intersection of transverse lines being positioned at different locations in the plane of the touch panel, each of the second conductive lines being operatively coupled to capacitive monitoring circuitry”	84
(f)	Claim [1F] - “wherein the capacitive monitoring circuitry is configured to detect changes in the charge coupling between the first conductive lines and the second conductive lines”	84
(g)	Claim [2] - “The touch panel as recited in claim 1 wherein the conductive lines on each of the layers are substantially parallel to one another”.....	85
(h)	Claim [3] - “The touch panel as recited in claim 2 wherein the conductive lines on different layers are substantially perpendicular to each other”	85
(i)	Claim [6] - “The touch panel recited in claim 1 wherein the conductive lines are formed from indium tin oxide (ITO)”	86

SUBJECT TO PROTECTIVE ORDER
CONTAINS HIGHLY CONFIDENTIAL – ATTORNEYS’ EYES ONLY INFORMATION

(j)	Claim [7] - “The touch panel as recited in claim 1, wherein the capacitive sensing medium is a mutual capacitance sensing medium”	86
(k)	Claim [8] -- “The touch panel as recited in claim 7, further comprising a virtual ground charge amplifier coupled to the touch panel for detecting the touches on the touch panel”	87
(l)	Claim [10A] – “A display arrangement having a screen for displaying a graphical user interface”	88
(m)	Claim [10B] -- “a transparent touch panel allowing the screen to be viewed therethrough and capable of recognizing multiple touch events that occur at different locations on the touch panel at a same time and to output this information to a host device to form a pixilated image”	88
(n)	Claim [10C] – “wherein the touch panel includes a multipoint sensing arrangement configured to simultaneously detect and monitor the touch events and a change in capacitive coupling associated with those touch events at distinct points across the touch panel”	89
(o)	Claim 10[D] – “wherein the touch panel comprises: a first glass member disposed over the screen of the display;	89
(p)	Claim [10E] – “a first transparent conductive layer disposed over the first glass member”	91
(q)	Claim [10F] – “the first transparent conductive layer comprising a plurality of spaced apart parallel lines having the same pitch and linewidths”	91
(r)	Claim [10G] – “a second glass member disposed over the first transparent conductive layer”	91
(s)	Claim [10H] – “a second transparent conductive layer disposed over the second glass member	92
(t)	Claim [10I] – “the second transparent conductive member comprising a plurality of spaced apart parallel lines having the same pitch and linewidths”	92
(u)	Claim [10J] – “the parallel lines of the second transparent conductive layer being substantially perpendicular to the parallel lines of the first transparent conductive layer”	92

SUBJECT TO PROTECTIVE ORDER
CONTAINS HIGHLY CONFIDENTIAL – ATTORNEYS’ EYES ONLY INFORMATION

(v)	Claim [10K] -- “a third glass member disposed over the second conductive layer”	92
(w)	Claim [10L] – “one or more sensor integrated circuits operatively coupled to the lines”	93
(x)	Claim [11] – “The display arrangement as recited in claim 10 further including dummy features disposed in the space between the parallel lines, the dummy features optically improving the visual appearance of the touch screen by more closely matching the optical index of the lines”	93
3.	The ‘607 Patent is Invalid in View of Mulligan	94
E.	Hsu Anticipates and/or Renders Obvious the Asserted Claims of the ‘607 Patent	94
2.	Analysis of the Claim Elements	95
(a)	Claim [1A] - “A touch panel comprising a transparent capacitive sensing medium configured to detect multiple touches or near touches that occur at a same time and at distinct locations in a plane of the touch panel and to produce distinct signals representative of a location of the touches on the plane of the touch panel for each of the multiple touches”	95
(b)	Claim [1B] - “wherein the transparent capacitive sensing medium comprises: a first layer having a plurality of transparent first conductive lines that are electrically isolated from one another”	97
(c)	Claim [1C] – “and a second layer spatially separated from the first layer and having a plurality of transparent second conductive lines that are electrically isolated from one another”	98
(d)	Claim [1D] – “the second conductive lines being positioned transverse to the first conductive lines”	99
(e)	Claim [1E] – “ the intersection of transverse lines being positioned at different locations in the plane of the touch panel, each of the second conductive lines being operatively coupled to capacitive monitoring circuitry”	100
(f)	Claim [1F] - “wherein the capacitive monitoring circuitry is configured to detect changes in the charge coupling	

SUBJECT TO PROTECTIVE ORDER
CONTAINS HIGHLY CONFIDENTIAL – ATTORNEYS’ EYES ONLY INFORMATION

	between the first conductive lines and the second conductive lines”	100
(g)	Claim [2] - “The touch panel as recited in claim 1 wherein the conductive lines on each of the layers are substantially parallel to one another”	101
(h)	Claim [3] - “The touch panel as recited in claim 2 wherein the conductive lines on different layers are substantially perpendicular to each other”	101
(i)	Claim [6] - “The touch panel recited in claim 1 wherein the conductive lines are formed from indium tin oxide (ITO)”	102
(j)	Claim [7] - “The touch panel as recited in claim 1, wherein the capacitive sensing medium is a mutual capacitance sensing medium”	102
(k)	Claim [8] -- “The touch panel as recited in claim 7, further comprising a virtual ground charge amplifier coupled to the touch panel for detecting the touches on the touch panel”	103
(l)	Claim [10A] – “A display arrangement having a screen for displaying a graphical user interface”	104
(m)	Claim [10B] -- “a transparent touch panel allowing the screen to be viewed therethrough and capable of recognizing multiple touch events that occur at different locations on the touch panel at a same time and to output this information to a host device to form a pixilated image”	105
(n)	Claim [10C] – “wherein the touch panel includes a multipoint sensing arrangement configured to simultaneously detect and monitor the touch events and a change in capacitive coupling associated with those touch events at distinct points across the touch panel”	105
(o)	Claim 10[D] – “wherein the touch panel comprises: a first glass member disposed over the screen of the display;	106
(p)	Claim [10E] – “a first transparent conductive layer disposed over the first glass member”	107
(q)	Claim [10F] – “the first transparent conductive layer comprising a plurality of spaced apart parallel lines having the same pitch and linewidths”	107

SUBJECT TO PROTECTIVE ORDER
CONTAINS HIGHLY CONFIDENTIAL – ATTORNEYS’ EYES ONLY INFORMATION

(r)	Claim [10G] – “a second glass member disposed over the first transparent conductive layer”	107
(s)	Claim [10H] – “a second transparent conductive layer disposed over the second glass member	108
(t)	Claim [10I] – “the second transparent conductive member comprising a plurality of spaced apart parallel lines having the same pitch and linewidths”	108
(u)	Claim [10J] – “the parallel lines of the second transparent conductive layer being substantially perpendicular to the parallel lines of the first transparent conductive layer”	108
(v)	Claim [10K] -- “a third glass member disposed over the second conductive layer”	108
(w)	Claim [10L] – “one or more sensor integrated circuits operatively coupled to the lines”	110
(x)	Claim [11] – “The display arrangement as recited in claim 10 further including dummy features disposed in the space between the parallel lines, the dummy features optically improving the visual appearance of the touch screen by more closely matching the optical index of the lines”	110
3.	The ‘607 Patent is Invalid in View of Hsu	111
F.	The ‘607 Named Inventors Copied and Derived Their Alleged Invention from Sony’s SmartSkin	111
XI.	THE COPYING AND DERIVATION FROM SONY’S SMARTSKIN IS MATERIAL TO THE PATENTABILITY OF THE ‘607 PATENT	116
XII.	SUMMARY OF OPINIONS OF INVALIDITY OF THE ‘129 PATENT	117
A.	The ‘129 Patent is Invalid due to Anticipation and/or Obviousness.	117
XIII.	TECHNICAL BACKGROUND PERTINENT TO THE 129 PATENT	118
A.	Capacitive Touch Sensing	119
B.	Mutual Capacitance	120
C.	Coupling of Sensors at Intersections	121
D.	LCD Modulated VCOM Noise and Approaches to Shielding	123
E.	Low-Impedance Drivers and Associated Shielding	124

**SUBJECT TO PROTECTIVE ORDER
CONTAINS HIGHLY CONFIDENTIAL – ATTORNEYS’ EYES ONLY INFORMATION**

F.	Market Need for Transparent Touchscreen	125
G.	Shielding in a Mutual Capacitance Sensor	125
XIV.	OVERVIEW OF 129 PATENT AND ASSERTED CLAIMS	127
A.	Summary.....	127
B.	The Asserted Claims.....	131
C.	The Prosecution History	136
1.	The Claims as Originally Filed.....	136
2.	December 22, 2009 Office Action.....	137
3.	March 5, 2010 Amendments and Remarks	141
4.	May 26, 2010 Office Action.....	143
5.	July 30, 2010 Amendments and Remarks	146
6.	October 15, 2010 Office Action	147
7.	October 28, 2010 Interview	147
8.	November 8, 2010 Amendments and Remarks	148
9.	January 14, 2011 Office Action.....	150
10.	February 4, 2011 Amendments and Remarks	151
11.	February 14, 2011 Notice of Allowance	152
D.	Priority Date	152
E.	Claim Construction.....	154
XV.	SCOPE OF THE PRIOR ART	154
B.	General Summary of the Prior Art	156
1.	Apple's Own/Admitted Prior Art.....	156
(a)	Hotelling '369 (the '607 patent)	156
(b)	Admitted Prior Art.....	156
C.	Overview of Exemplary Prior Art to the '129 Patent	158

SUBJECT TO PROTECTIVE ORDER
CONTAINS HIGHLY CONFIDENTIAL – ATTORNEYS’ EYES ONLY INFORMATION

1.	GlidePoint (Exhibit 129-1)	158
2.	Gerpheide '658 (Exhibit 129-2)	159
3.	Velos (Exhibit 129-3)	160
4.	Philipp '898 (Exhibit 129-4)	161
5.	Hotelling '369 (Exhibit 129-5).....	162
XVI.	INVALIDITY OF THE '129 PATENT	164
A.	Anticipation	164
1.	Cirque GlidePoint System (Exhibit 129-1)	164
2.	Gerpheide '658 (Exhibit 129-2)	165
3.	Velos (Exhibit 129-3)	166
4.	Philipp '898 (Exhibit 129-4)	167
5.	Hotelling '369 (Exhibit 129-5).....	168
B.	Obviousness.....	169
XVII.	INDEFINITENESS	170
XVIII.	MISCELLANEOUS	172
A.	Supplementation of Opinions	172
B.	Compensation	172

**SUBJECT TO PROTECTIVE ORDER
CONTAINS HIGHLY CONFIDENTIAL – ATTORNEYS’ EYES ONLY INFORMATION**

I. INTRODUCTION

1. I have been retained by counsel for the following defendants in this action: Samsung Electronics Co., Ltd., a Korean business entity; Samsung Electronics America, Inc., A New York Corporation; and Samsung Telecommunications America, LLC, a Delaware limited liability company. I have been retained to give expert opinions related to technical matters at issue in the case *Apple, Inc., vs. Samsung Electronics Co., Ltd., et al.* I am an independent expert, I have been asked to opine on the validity of Claims 1-3, 6-8, 10 and 11 of U.S. Patent 7,663,607 (the “ ‘607 patent”) and Claims 1-3, 5, 7, 9-12, 14, 16-19, 21, 22, 24-26, and 28 of U.S. Patent 7,920,129 (the “ ‘129 patent”).

II. PROFESSIONAL BACKGROUND

2. I received a Bachelor’s degree from Princeton University in 1980 in Physics. I received a Masters of Science degree in 1984 and a Ph.D. in 1989 from the California Institute of Technology (“Caltech”) in VLSI and Computer Graphics. During and after my graduate studies, part of my research required the design and development of multiple custom integrated circuits. At Caltech, I was awarded a Hertz Foundation Fellowship and a Hughes Foundation Fellowship.

3. From 1992 to 1994 I worked for Synaptics, Inc. in the engineering of electronic circuits for human interface devices such as the TouchPad, which was developed by Synaptics in the 1990’s.

4. I am presently the Chief Executive Officer of Rapid Prototypes, Inc., an electronics consultancy specializing in the research, design and development of commercial electronic products, and have been with the company since 1994. Over the past two decades, I have designed dozens of electronic systems for several Fortune 500 companies, including human interface devices, signal processing systems, graphics and video processing systems.

**SUBJECT TO PROTECTIVE ORDER
CONTAINS HIGHLY CONFIDENTIAL – ATTORNEYS’ EYES ONLY INFORMATION**

5. I am the inventor on a dozen electronics patents and a dozen patents pending.

6. I am a member of the Institute of Electrical and Electronic Engineers (IEEE), and am the author or co-author of published articles related to signal processing and computer graphics. I have given numerous invited seminars at leading conferences and institutions around the world on the topics of digital signal processing, electronic systems engineering, and hardware / software co-design.

7. Further details of my background, as well as a listing of the cases in which I have provided expert testimony, are set forth in my current curriculum vitae (“CV”), a copy of which is attached as Exhibit A.

8. I believe that my industry experience in electronic design of human interface devices and other related technologies, along with my academic experience and credentials, qualify me as an expert in the technical areas relevant to the subject matter of the ‘607 and ‘129 patents.

III. MATERIALS CONSIDERED FOR THIS REPORT

9. Exhibit B lists the materials I considered in formulating the expert opinions expressed in this report. As a general matter, I have reviewed and considered every document cited herein and those cited in the attached exhibits.

IV. APPLICABLE LEGAL PRINCIPLES

10. I am not a legal expert and offer no opinions of the law. However, I have been informed by counsel of the following relevant legal standards that apply with respect to patent law, and I have applied these legal standards in arriving at my conclusions.

**SUBJECT TO PROTECTIVE ORDER
CONTAINS HIGHLY CONFIDENTIAL – ATTORNEYS’ EYES ONLY INFORMATION**

A. Claim Construction

11. I am informed by counsel that when interpreting the claims of a patent, the court first looks at the intrinsic evidence in the following order: the plain claim language, the specification and the prosecution history. The specification and prosecution history often can inform the meaning of the claim language by demonstrating how the inventor understood the invention and whether the inventor limited the invention. Extrinsic evidence can also be relevant in determining the meaning of claims.

B. Anticipation

12. I am informed by counsel that “prior art” includes public information, public knowledge and public acts that occur before an application for a patent was filed (in this case, May 6, 2004). Prior art also includes patents, journals, Internet publications, systems and products.

13. I am further informed by counsel that prior art renders a patent claim invalid by describing all of the limitations of the claim, as those limitations are construed by the Court. I understand, however, that all limitations of the claim need not be shown directly so long as all limitations are necessarily present in the prior art reference and thus are inherent.

14. I am further informed by counsel that Section 102 of the Patent Act provides that “[a] person shall be entitled to a patent unless... (a) the invention was known or used by others in this country, or patented or described in a printed publication in this or a foreign country, before the invention thereof by the applicant for patent, or ... (b) the invention was patented or described in a printed publication in this or a foreign country or in public use or on sale in this country, more than one year prior to the date of the application for patent in the United States, or ... (g) ... (2) before such person’s invention thereof, the invention was made in this country by another inventor who had not abandoned, suppressed, or concealed it.”

**SUBJECT TO PROTECTIVE ORDER
CONTAINS HIGHLY CONFIDENTIAL – ATTORNEYS’ EYES ONLY INFORMATION**

15. I have been informed by counsel that the evidence must be “clear and convincing” for a claim to be found invalid.

C. Obviousness

16. I am informed by counsel that a patent claim is invalid if the claim would have been obvious to a person of ordinary skill in the art at the time the patent was filed. I am informed by counsel that the standard for determining obviousness was clarified by the Supreme Court of the United States in *KSR Int’l Co. v. Teleflex Inc.*, 550 U.S. 298 (2007).

17. I am further informed by counsel that the obviousness analysis is expansive and flexible. I also understand that a combination of familiar elements according to known methods is likely to be obvious when it does no more than yield predictable results, and that when a patent claims a structure already known in the prior art that is altered by the mere substitution of one element for another known in the field, the combination must do more than yield a predictable result. I also understand that in *KSR* the Supreme Court found that: “When a work is available in one field of endeavor, design incentives and other market forces can prompt variations of it, either in the same field or a different one. If a person of ordinary skill can implement a predictable variation, §103 likely bars its patentability. For the same reason, if a technique has been used to improve one device, and a person of ordinary skill in the art would recognize that it would improve similar devices in the same way, using the technique is obvious unless its actual application is beyond his or her skill....a court must ask whether the improvement is more than the predictable use of prior art elements according to their established functions.” Further, “it can be important to identify a reason that would have prompted a person of ordinary skill in the relevant field to combine the elements in the way the claimed new invention does.”

**SUBJECT TO PROTECTIVE ORDER
CONTAINS HIGHLY CONFIDENTIAL – ATTORNEYS’ EYES ONLY INFORMATION**

18. I am also informed by counsel that the plaintiff can rebut a showing of obviousness over the prior art by showing “secondary considerations“ of non-obviousness. I am further informed, however, that it is plaintiff’s burden to make a showing of secondary considerations. Thus, I have not included any opinions of secondary considerations of non-obviousness in this report. If the plaintiff should attempt to show secondary considerations of non-obviousness, I hereby reserve my right to address those claims in a supplemental report or at trial.

D. Indefiniteness

19. I understand that a patent specification must conclude with one or more claims particularly pointing out and distinctly claiming the subject matter that the applicant regards as his invention. Claims are indefinite if they do not reasonably apprise those skilled in the relevant art of the applicant's intended scope of the invention when read in light of the specification and it is invalid as indefinite.

20. I understand that in a means-plus-function claim in which the disclosed structure is a computer, or microprocessor, programmed to carry out an algorithm, the disclosed structure is not the general purpose computer, but rather the special purpose computer programmed to perform the disclosed algorithm. Absent any such algorithm, the claim lacks sufficient disclosure of structure and is therefore indefinite.

21. I understand that indefiniteness must be proven by clear and convincing evidence. I have written this Report with the understanding that indefiniteness must be shown by clear and convincing evidence.

**SUBJECT TO PROTECTIVE ORDER
CONTAINS HIGHLY CONFIDENTIAL – ATTORNEYS' EYES ONLY INFORMATION**

E. Conception and Reduction to Practice

22. I further understand that many of the different categories of prior art refer to the date at which the inventor made the invention. This is called the "date of invention."

23. I understand that there are two parts to the making of an invention: "conception" and "reduction to practice."

24. I have been advised that when the inventor first has the idea of the invention, this is referred to as "conception" of the invention. Conception is the formation in the mind of the inventor, of a definite and permanent idea of the complete and operative invention, as it is hereafter to be applied in practice. A conception of an invention is complete when the inventor has formed the idea of how to make and use every aspect of the claimed invention, and all that is required is that it be made without the need for any further inventive effort.

25. I am also informed that the actual making of the invention is referred to as "reduction to practice." An invention is said to be "reduced to practice" when it is made and shown to work for its intended purpose. I understand that the filing of a patent application serves as conception and constructive reduction to practice of the subject matter described in the application.

F. Priority Date

26. I further understand that the "critical date" for a patent is one year prior to its filing date. It is my understanding that the critical date is significant because patents, systems, or documents that are public prior to the critical date, if they disclose each and every limitation of the claims, will invalidate a patent regardless of whether the inventors invented the claim.

27. I further understand that the "priority date" of a patent is the date on which it is filed. I further understand that the priority date is significant because patents, systems, or

**SUBJECT TO PROTECTIVE ORDER
CONTAINS HIGHLY CONFIDENTIAL – ATTORNEYS’ EYES ONLY INFORMATION**

documents that are public less than one year prior to the priority date may invalidate the claims. My understanding is that, for such prior art references, a patentee may attempt to show that the claimed invention was conceived prior to the publication date of the prior art reference.

28. I understand that a patent may be valid over prior art that was published or was publicly available before the priority date but after the critical date. To do so, it is my understanding that Complainant must prove with corroborating evidence that the named inventors conceived of the claimed invention before the prior art, and were diligent in reducing the claimed inventions to practice.

G. Derivation

29. I have been informed that a patent claim can be invalid because it was derived from the invention of another. I have been informed that a claimed invention is unpatentable if the invention is conceived by another person, and the prior conception is communicated to the patentee. I have been informed that the communication need only be sufficient to enable one of ordinary skill in the art to make the patented invention.

30. I have been informed that if a communication of a prior conception does not enable one of ordinary skill in the art to make the patented invention, the communication of a prior conception may still be used in combination with other prior art to render an invention obvious. I have been informed that the communication of a prior conception need not be a public statement. Non-public or secret communications between the person who conceived the invention and the patentee may still be used to render the patent invalid as obvious as derived.

H. Inequitable Conduct

31. I have been informed and understand that inventors owe a duty of candor and good faith in dealing with the USPTO, which includes a duty to disclose to the Patent Office all non-cumulative information known to them to be material to patentability. I understand that

**SUBJECT TO PROTECTIVE ORDER
CONTAINS HIGHLY CONFIDENTIAL – ATTORNEYS’ EYES ONLY INFORMATION**

breach of the duty of candor can constitute inequitable conduct which results in rendering the patent unenforceable.

32. I have been told that information is deemed material if there is a substantial likelihood that a reasonable examiner would consider it important in deciding whether to allow the application to issue as a patent.

33. I have been informed that information not cumulative of information already of record in the application is deemed material to the examination of an application if it establishes, by itself or in combination with other information, that a claim was unpatentable or that it is inconsistent with an argument relating to patentability made by the applicant during prosecution. I have also been informed that information is cumulative if it is duplicative of, or less pertinent than, prior art already of record in the application.

34. I understand that this duty of disclosure extends beyond documents that render an invention anticipated. I have been informed that art is deemed material if it shows that the invention would have been obvious to one skilled in the pertinent art. Materiality also encompasses any document, regardless of date or confidentiality, that shows that the invention was taken or merely derived from the work of another.

V. PERSON OF ORDINARY SKILL IN THE ART

35. I am informed by counsel that when analyzing the validity of a patent, one does so from the viewpoint of one of ordinary skill in the art at the time of the filing of the patent application. For the purposes of this report, a person of ordinary skill in the art in May, 2004 (for the '607 patent) and in January, 2007 (for the '129 patent) would have had an undergraduate degree in electrical engineering, physics, computer engineering, or a related field and 2-3 years of work experience with input devices.

**SUBJECT TO PROTECTIVE ORDER
CONTAINS HIGHLY CONFIDENTIAL – ATTORNEYS’ EYES ONLY INFORMATION**

VI. SUMMARY OF OPINIONS OF INVALIDITY OF THE ‘607 PATENT

A. The Initial Determination of the International Trade Commission Found the ‘607 Patent Invalid on Two Separate Grounds

36. I understand that ALJ Essex of the International Trade Commission recently issued an Initial Determination regarding the validity of the ‘607 patent (“750 ID”). (See Exhibit 607-01, Inv. No. 337-TA-750, Initial Determination, issued January 13, 2012). I have attached the 750 ID to this report as Exhibit 607-01. I have read the 750 ID, and I agree with all of ALJ Essex’s decisions regarding the invalidity of the ‘607 patent.

37. I understand that in that investigation, Apple asserted the same ‘607 patent against Motorola, Inc. and Motorola Mobility, Inc. After considering the expert reports of both sides and after a full hearing on the merits, ALJ Essex agreed with the Commission Investigative Staff that all the asserted claims of the ‘607 patent were invalid due to prior art. Most notably, ALJ Essex determined that all the claims of the ‘607 patent were invalid based on two, independent grounds. (*Id.*). In other words, two different prior art bases rendered the ‘607 patent invalid.

38. First, ALJ Essex found the ‘607 patent invalid because it was anticipated by U.S. Patent No. 7,372,455 to Perski et al. (“Perski ‘455”). (*Id.* at 146-46). The only claim limitation Apple alleged was missing from Perski ‘455 was the multitouch limitation in each of independent claims 1 and 10. (*Id.* at 143). ALJ Essex dismissed Apple’s assertions, finding that the “method disclosed in Perski ‘455 for detecting multiple touches is virtually identical to the disclosure in the ‘607 Patent.” (*Id.* at 144).

39. Second, ALJ Essex found the ‘607 patent invalid in view of the Sony Smartskin paper (“Smartskin”). (*Id.* at 172-73). Although the Commission Investigative Staff determined that Smartskin anticipated all the asserted claims, ALJ Essex found that anticipation in view of Smartskin was an “extremely close call.” (*Id.* at 147 (emphasis in original)). While not finding

SUBJECT TO PROTECTIVE ORDER
CONTAINS HIGHLY CONFIDENTIAL – ATTORNEYS’ EYES ONLY INFORMATION

anticipation in view of Smartskin, ALJ Essex did find that Smartskin rendered all the asserted claims of the ‘607 patent obvious either by itself or in conjunction with Japanese Patent Application Pub. No. 2002-342033A to Rekimoto (“Rekimoto”), the same author of the Smartskin paper. (*Id.* at 172-76).

40. As mentioned above, I have reviewed the 750 ID and agree with ALJ Essex's and the Commission Investigative Staff's finding that Perski ‘455 anticipates all the asserted claims of the ‘607 patent. I also agree with the Commission Investigative Staff's finding that Smartskin anticipates all the asserted claims. With respect to ALJ Essex's obviousness determination, I further agree that if Smartskin does not anticipate the asserted claims, it at least renders all the asserted claims obvious, either by itself or in view of Rekimoto.

41. The full Commission recently reviewed ALJ Essex's Initial Determination and affirmed the ALJ's determination of no violation of the Tariff Act. (See Commission Decision issued March 16, 2012, Exhibit 607-02 at 1). The Commission decided not to review the anticipation determination in view of Perski ‘455. The Commission decided to review the obviousness determination in view of Smartskin, and on review, modified the Initial Determination but affirmed the ALJ's obviousness determination.¹ (*Id.* at 3).

42. As analyzed below, I also believe that Perski ‘455 and Smartskin invalidate the asserted claims. Although I understand that ITC precedent is not necessarily binding on this Court, I find the ALJ's Initial Determination and the Commission's decision to affirm the ALJ's determination to be highly persuasive.

¹ I am informed that the Commission's full opinion has not yet issued and reserve the right to supplement this report when the decision becomes available. Although the full Commission modified the ID with respect to the obviousness determination in view of Smartskin and Rekimoto, the full Commission still affirmed ALJ Essex's obviousness determination and specifically noted that “Motorola has demonstrated by clear and convincing evidence that the asserted claims of the ‘607 Patent are invalid under 35 U.S.C. § 103.” (*Id.*)

**SUBJECT TO PROTECTIVE ORDER
CONTAINS HIGHLY CONFIDENTIAL – ATTORNEYS’ EYES ONLY INFORMATION**

B. The Priority Date of the ‘607 Patent

43. It is my opinion that Apple has not shown a date of conception or reduction to practice of the asserted claims before May 6, 2004—the filing date of the ‘607 patent. It is my understanding that Apple has identified numerous documents in its Fifth Amended Objections and Responses to Samsung’s Interrogatory No. 1, including APLNDC0000032955-57; APLNDC0000032968-69; APLNDC0000033036-063; APLNDC0000033123-26; APLNDC0000033885-4133; APLNDC0000033075-76; APLNDC00033079-080; APLNDC00033095-3100; and APLNDC0000039221 as evidence concerning conception and/or reduction to practice of the asserted claims of the ‘607 patent. I have reviewed each of these documents and based on the apparent date that each document was created, I have compared them to the asserted claims. It is my opinion that the documents predating May 6, 2004 that Apple has identified do not individually or in combination disclose each and every element of any asserted claim of the ‘607 patent. As such, it is my opinion that these documents do not indicate that Apple was in possession of the claimed invention of the asserted claims of the ‘607 patent prior to May 6, 2004.

44. [REDACTED]

[REDACTED]

[REDACTED]

[REDACTED]

[REDACTED]

[REDACTED]

[REDACTED]

[REDACTED]

[REDACTED]

**SUBJECT TO PROTECTIVE ORDER
CONTAINS HIGHLY CONFIDENTIAL – ATTORNEYS’ EYES ONLY INFORMATION**

[REDACTED]

[REDACTED]

[REDACTED]

[REDACTED]

45. Almost all of the documents merely reflect tentative discussions regarding the general concept of a transparent touch panel. No substantive technical details relating to the asserted claims of the ‘607 patent are disclosed except for the very general concept of a transparent panel that can recognize multiple touches. Moreover, as described below, this general concept was derived from Jun Rekimoto and Mr. Rekimoto’s Smartskin device and *not* the inventors of the ‘607 patent. *See* § X(F) below. As such, there is no basis for a claim of conception or reduction to practice prior to May 6, 2004.

C. The ‘607 Patent is Invalid due to Anticipation and/or Obviousness.

46. It is my opinion that claims 1-3, 6-8, 10, and 11 (the “Asserted Claims”) of the ‘607 patent are invalid due to anticipation and/or obviousness.²

47. It is my opinion that U.S. Patent No. 7,372,455 to Perski et al. (“Perski ‘455”), which expressly incorporates by reference U.S. Prov. Pat. App. No. 60/406,662 (“Perski ‘662”), anticipates claims 1-3, 6-8, 10 and 11 of the ‘607 patent.

48. It is my opinion that Japanese Patent 2002-342033 to Rekimoto, published on November 29, 2002 (“Rekimoto”), anticipates claims 1-3, 7, 8, and 10 of the ‘607 patent. It is also my opinion that Rekimoto renders obvious claims 6 and 11 of the ‘607 patent.

² To the extent any asserted claim is not anticipated by a reference I describe below, it is my opinion that it is rendered obvious by that reference, either alone or in combination with one of the other references described below or described in Appendix 607-03, Exhibit P to Samsung’s P.L.R. 3-3 and 3-4 Disclosures, which is incorporated into my report in its entirety.

**SUBJECT TO PROTECTIVE ORDER
CONTAINS HIGHLY CONFIDENTIAL – ATTORNEYS’ EYES ONLY INFORMATION**

49. It is my opinion that the published paper, “Smartskin: An Infrastructure for Freehand Manipulation on Interactive Surfaces,” Conference on Human Interaction 2002, April 20-25, 2002 Minneapolis, Minnesota, USA, by Jun Rekimoto, (“Smartskin”) anticipates claims 1-3, 6-8 and 10 of the ‘607 patent. It is also my opinion that Smartskin further renders obvious claim 11 of the ‘607 patent.

50. It is my opinion that U.S. Patent 6,970,160 (“Mulligan) anticipates claims 1-3, 6-8, 10 and 11 of the ‘607 patent.

51. It is my opinion that U.S. Patent 7,030,860 (“Hsu”), which expressly incorporates by reference U.S. Patent Nos. 5,880,411 (“Gillespie”) and 5,305,017 (“Gerpheide”), anticipates claims 1-3, 6-8, 10 and 11 of the ‘607 patent.

52. It is my opinion that the ‘607 named inventors copied and derived their alleged invention from Sony’s SmartSkin.

53. It is my opinion that the copying and derivation from Sony’s SmartSkin is material to the patentability of the ‘607 patent.

VII. TECHNICAL BACKGROUND PERTINENT TO THE ‘607 PATENT

54. The ‘607 patent relates to an improved type of touchscreen. Touchscreens have been commercially available and used in computer systems for at least thirty-five years. The words touchscreen, touch screen and touch panel are increasingly used interchangeably to describe one or more of the components of an input device for an electronic device that usually consist of: (1) a nominally transparent physical panel with which an intended operation can be initiated by touching with the user’s finger or a stylus of some type, (2) electronic circuitry that controls the operation of the panel using some physical principle in combination with the electronic circuitry, and circuitry which also generates a communications signal carrying the

**SUBJECT TO PROTECTIVE ORDER
CONTAINS HIGHLY CONFIDENTIAL – ATTORNEYS’ EYES ONLY INFORMATION**

result of touch input to the transparent panel, usually in the form of data (“touch data”) that includes at least the coordinate pair or pairs of locations touched on the transparent panel; and (3) software that resides on the computer system, whether at the operating system or application program level, which interprets the touch data and performs the action intended by the user.

55. Although a touchscreen as described above is usually not a display device itself (e.g., a computer video monitor), a touchscreen is most commonly used with a display device, and is sized to match its touch-sensitive area to the viewable area of the display device, and is mechanically mounted in close proximity to the display device, often with transparent adhesives which minimize internal reflections between the touchscreen and the display. In this configuration the transparent panel may become indistinguishable from the display device, and indeed, this is a usual design objective for a touchscreen-equipped computer display or other touchscreen controlled device. As a result, the word touchscreen may be used to refer to the combination of the display device and at least the transparent panel, or the entire touch controlled device itself.

56. An opaque version of a touchscreen, frequently used in laptop computers and in previously in some desktop computer keyboards, is a touch-operated device generally known as a “touch pad” or “touchpad.” The purpose of a touchpad is usually as an alternative to a mouse or other pointing device. The technology used in touchpads has been resistive, surface capacitive and projected capacitive, but is most commonly projected capacitive. These devices may be constructed from materials similar to their touchscreen counterparts, but particularly for the projected capacitive type are more commonly constructed of less expensive materials such as copper and fiberglass printed circuit boards (PCBs). Some touchpad devices evolved into transparent touchscreens and some touchpads came from their touchscreen counterparts.

SUBJECT TO PROTECTIVE ORDER
CONTAINS HIGHLY CONFIDENTIAL – ATTORNEYS’ EYES ONLY INFORMATION

57. Several types of touchscreen systems were commercially available at the time of the filing of the patent application of the present invention, including resistive, capacitive, optical and electromechanical. All of these touchscreens have design features and limitations that figured into their invention, development and manufacture, and applications for each type often persist based on those design considerations.

58. Resistive touchscreens are based on the principle of a resistive voltage divider, implemented with a uniform layer or layers of a transparent conductive material coated on two transparent substrates. The simplest implementation of a resistive touchscreen is known as a four-wire resistive touchscreen. A voltage applied across the first conductive layer by the electronic circuitry mentioned above (usually referred to as a controller) produces a linear electric field across the substrate. Voltage in the direction of the field is thus proportional to position. Two substrates are positioned with the conductive layer facing each other, with a narrow gap between them. A touch causes the conductive layers to contact, and the second layer picks off the voltage present at the position beneath the touch on the first layer. A one-axis position sensor is thus created. In the orthogonal direction (most touchscreens have orthogonal structures for generating and processing touch position) the same process is then implemented with the second layer being driven by the controller, with the first layer picking off the voltage of the second layer. This sequential detection of position in orthogonal axes (which are aligned with the major axes of the display panel, and are thus generated as familiar X-Y Cartesian coordinates) is incorporated in almost all touchscreen technologies, regardless of the physical principle of operation employed. A variation on the four-wire resistive touchscreen described here includes only a single uniform conductive substrate, with a pickoff layer positioned above it, and is known as a five-wire resistive touchscreen. Switched potentials applied to a resistive

SUBJECT TO PROTECTIVE ORDER
CONTAINS HIGHLY CONFIDENTIAL – ATTORNEYS’ EYES ONLY INFORMATION

network connected to the periphery of the uniform conductive substrate allow sequential orthogonal electric fields to be developed on the substrate, and the voltage corresponding to a position is always picked off by the upper conductive layer, which is not required to be uniformly conductive. Resistive touchscreen controllers are universal—a single controller can operate all four-wire resistive touchscreens, regardless of size or shape, and the same is true for five-wire controllers. This feature is a significant feature of the relatively low cost of resistive touchscreen systems.

59. Early capacitive touchscreens, now referred to as *surface* capacitive touchscreens to differentiate them from the *projected* capacitive touchscreens of the present invention, are similar to five-wire resistive touchscreens, but with no pickoff layer. An AC potential is applied to the corners of the resistive network attached to a uniform conductive substrate. The substrate is coated with a thin dielectric layer to prevent damage to the underlying conductive layer and can also be used to improve the optics of the touchscreen. Contact to the substrate by a conductive object such as the user’s finger causes current to flow from each corner of the network. Various ratios of current in the different “legs” of the resistive network are computed to determine the touch position. It is essential that the user’s body is at least loosely coupled to the ground path of the touchscreen controller for proper function of this touchscreen. As with resistive touchscreen systems, surface capacitive touchscreen controllers are universal.

60. One type of electromechanical touchscreen is known as surface acoustic wave (SAW). Despite the popular interpretation the name suggests, the waves are neither airborne nor audible. Electromechanical transmit transducers create a vibration in the surface of a glass substrate with short bursts of high frequency (4-10MHz) waves. These waves propagate across the touch surface by the action of arrays of partial reflectors around the periphery of the

SUBJECT TO PROTECTIVE ORDER
CONTAINS HIGHLY CONFIDENTIAL – ATTORNEYS’ EYES ONLY INFORMATION

touchscreen. Each axis is driven in sequence. The summed output from all of the wave paths from one axis is captured by a receive transducer identical to the transmit transducer and converted to an electrical signal, which is digitized and stored in the controller. When no touch is present, this waveform becomes a reference “map” for subsequent touch detection. Touch by a user’s finger or other soft stylus (which does not have to be electrically conductive) attenuates the wave passing by the touch location, resulting in a locally attenuated response in a new captured waveform. This new waveform is compared to the reference map to detect the presence of a touch for one axis. A similar process detects touch in the other axis. SAW touchscreens do not require the use of a conductive substrate, and many different types of glass may be used to accommodate different application requirements. SAW touchscreen controllers are universal.

61. Another type of electromechanical touchscreen is generally known as a bending wave touchscreen. One touchscreen that operates on this principle computes touch position by computing time of flight a vibration, generated by a touch, to an array of transducers positioned around the periphery of a glass plate. Another compares the vibration signature of a touch at a given location to a stored map of nominal vibration signatures at the same location.

62. An early type of optical touchscreen is known as “scanning infrared.” An array of pairs of infrared wavelength (IR) photodiodes and opposing phototransistors is placed near the surface of an intended touch surface or space, with one array in each axis. The pitch between adjacent pairs of diodes and transistors is usually very small, and in many early touchscreens was limited entirely by the physical size of the IR devices. When used with a display that has a relatively weak surface, such as a liquid crystal display (LCD), a protective lens is used for the display that also serves as a touch surface, and this lens may be incorporated into the touchscreen structure itself. Touch is detected by turning on each diode-transistor pair in sequence in each

SUBJECT TO PROTECTIVE ORDER
CONTAINS HIGHLY CONFIDENTIAL – ATTORNEYS’ EYES ONLY INFORMATION

axis, and detecting touch by the blocking of the IR light beam from the transistor by the user’s finger or stylus. Interpolation and processing beams at multiple adjacent transistors extends the resolution of this otherwise rather coarse resolution touchscreen. Newer versions of this technology use waveguides coupled to a single IR light source to replace all the photodiodes and an integrated circuit-based detector array to replace the discrete phototransistors. It is unclear whether or not this waveguide technology existed at the time of the filing of the patent application for present invention.

63. Many variations of front-mounted optical camera based systems exist today. An IR light source broadly illuminates the front surface of a display panel in a narrow plane close and parallel to the display surface. Reflections from the touch object—a finger or generally arbitrary stylus—are detected by optical sensors (cameras) with good azimuth resolution and accuracy mounted in the top left and right corners of the outer surface of the display panel, inside the display bezel. A single touch is detected and triangulated by the cameras, each of which can “see” the entire display surface.

64. Other optical systems using rear or edge mounted cameras to sense perturbations of the touch surface also exist. These touchscreen systems generally did not commercially exist at the time of the filing of the patent application of the present invention.

65. Paragraph 35 describes the surface capacitive touchscreen technology. Another capacitive technology is projected capacitive. Each axis of this type of touchscreen is typically comprised of arrays of equal width and equally spaced parallel lines (or stripes, or electrodes, etc.) of transparent conductive material such as ITO or conductive polymer such as Orgacon, etc., very small diameter (~10um) metal wire or very narrow lines of printed or deposited conductors, such as silver, copper, carbon nanotubes, graphene and the like. Some of these

SUBJECT TO PROTECTIVE ORDER
CONTAINS HIGHLY CONFIDENTIAL – ATTORNEYS’ EYES ONLY INFORMATION

materials were not available at the time of the filing of the application for the ‘607 patent, but serve to illustrate the range of possible implementations in a practical touchscreen electrode array that would be obvious to one of ordinary skill in the art. Some “lines” are actually arrays of transparent diamond-shaped pads that are connected by a very small transparent conductive runner from a vertex of one diamond to the vertex of the next diamond in the array. The axis of these arrays of diamonds is a straight line, and should be considered as lines, in my opinion. Regardless of the specific construction, the intent is to produce essentially invisible lines. The two axes of the touchscreen are deposited on a single transparent substrate or built up from depositions on two substrates with the arrays positioned orthogonally. The arrays are separated in the “Z” axis by a small distance, typically 1mm or less. The arrays are further separated from the intended touching surface by a similarly small distance by adding another dielectric layer over the upper conductive array. Controller circuitry to measure capacitance is connected to each line in one or both axes depending on the type of position sensing that is used. Position sensing is usually accomplished by one of the following methods: (1) Driving each stripes in each axis in sequence with an AC signal from the controller and measuring the amplitude of the signal across an appropriate load. When a finger or other conductive stylus approaches or touches the touchscreen surface, capacitive coupling to nearby array stripes attenuates the AC signal. This attenuation is measured and can be interpreted as a touch in the vicinity of the stripe or stripes. As the spacing between adjacent stripes is similar or slightly smaller than typical fingers or styli, the finger usually affects the capacitance of more than one stripe. Interpolation of the magnitudes of the affected stripe capacitances significantly increases the resolution of the touch position. This type of sensing is usually called “self capacitance” sensing. (2) Driving each stripe with an AC signal in one axis in sequence and measuring the amplitude of the same signal

SUBJECT TO PROTECTIVE ORDER
CONTAINS HIGHLY CONFIDENTIAL – ATTORNEYS’ EYES ONLY INFORMATION

which is coupled to each of the stripes in the orthogonal axis. The coupling is the result of the small capacitor which forms between the crossings of each stripe in one axis with each stripe in the orthogonal axis. A touch at or near any of the crossed stripe capacitors of the touchscreen forms another capacitor between the stripes and the touch finger or conductive stylus (it must be conductive) which takes coupling away from the measurement axis. This causes a reduction in the signal on the measurement axis, which is measured and interpreted as a touch. This type of sensing is called “mutual capacitance” sensing, as the capacitance is measured between nearby circuit elements (the stripes) rather than between a circuit element and a fixed reference point (eg., ground). The same interpolation concept as described for self capacitance applies in the mutual capacitance sensing touchscreen.

66. Resistive and surface capacitive touchscreens, which are constructed from transparent conductive films sputtered onto plastic and/or glass substrates, generally must be calibrated at least once to the display that they are mounted over, because of variations in the resistivity of the transparent conductive material caused by manufacturing processes in material and assembly. They may also change in touch location/output relationship due to wear and material degradation. Projected capacitive touchscreen coordinate output resulting from a touch in a given location is virtually identical from unit to unit. This is a consequence of the sensing method which references each touch to a specific stripe, which is in a fixed position, adjusted by the interpolation among adjacent stripes which are also in a fixed position. This position sensing is essentially unaffected by material variations. SAW touchscreens nominally produce the same coordinate output for a touch in a specific position. However, SAW touchscreen controllers may “resize” the touchscreen and alter the touch location/output relationship if contamination that

SUBJECT TO PROTECTIVE ORDER
CONTAINS HIGHLY CONFIDENTIAL – ATTORNEYS’ EYES ONLY INFORMATION

affects touch—especially liquids—stays at one end of a reflector array for a period of time.

Optical touchscreens usually do not require calibration and do not suffer from wear.

67. Optics of touchscreens can be very important, especially outdoors and indoors near windows, during daylight hours. The touchscreens most badly affected by these environments are those manufactured with conductive coatings—resistive and both surface and projected capacitive types. Optical and electromechanical types can more easily be enhanced to counter the effects of difficult lighting.

68. Electromagnetic interference (EMI) is a potential problem in any electronic assembly. The touchscreens most affected by system EMI are the capacitive types, both surface and projected.

69. In addition to single touch technology, multi-touch developed as an effective approach for capturing gestures, distinguishing significant touches from accidental ones, and increasing the expressiveness and power of human computer interactions. Multi-touch technology enables the identification of multiple simultaneous contact points on or in the proximity of the touch sensitive surface. Providing these multiple concurrent stimuli to applications enables a richer set of interactions to be performed, i.e. panning, zooming, rotating, that otherwise would be less intuitive with single touch operations.

70. Operational charge amplifiers are key elements of touch sensing. They sense the change in charge at the input to the operational amplifier or “op-amp,” responding to the change in charge with an amplified change in output voltage.

71. Inherent in many charge amplifiers is associated Miller capacitance, which is the capacitance between the input and the output of the operational amplifier. Absent other feedback, it is the Miller capacitance that provides the capacitive feedback that makes an op-amp

**SUBJECT TO PROTECTIVE ORDER
CONTAINS HIGHLY CONFIDENTIAL – ATTORNEYS’ EYES ONLY INFORMATION**

respond as a charge amplifier. The Miller theorem states that the Miller capacitance can be treated as an equivalent pair of capacitors to ground, providing a virtual ground circuit.

VIII. OVERVIEW OF THE 607 PATENT AND THE ASSERTED CLAIMS

72. The ‘607 patent, entitled “Multipoint Touchscreen” was filed on May 6, 2004 and issued on February 16, 2010. The patent has three named inventors: Steve Hotelling, Joshua A. Strickon and Brian Q. Huppi.

B. The Specification

73. The ‘607 patent is directed toward a touch panel having a “transparent capacitive sensing medium” configured to detect multiple touches or near touches that occur at the same time and at distinct locations on the touch panel and to produce distinct signals representative of those touches.

74. As shown in Figures 9, below, the touchscreen includes a grid of transparent conductive lines or traces. These conductive lines are arranged in two layers – one layer of straight horizontal lines (called “rows” in the ‘607 patent) and one layer of straight vertical lines (called “columns” in the ‘607 patent). The conductive lines in each layer are parallel to each other.

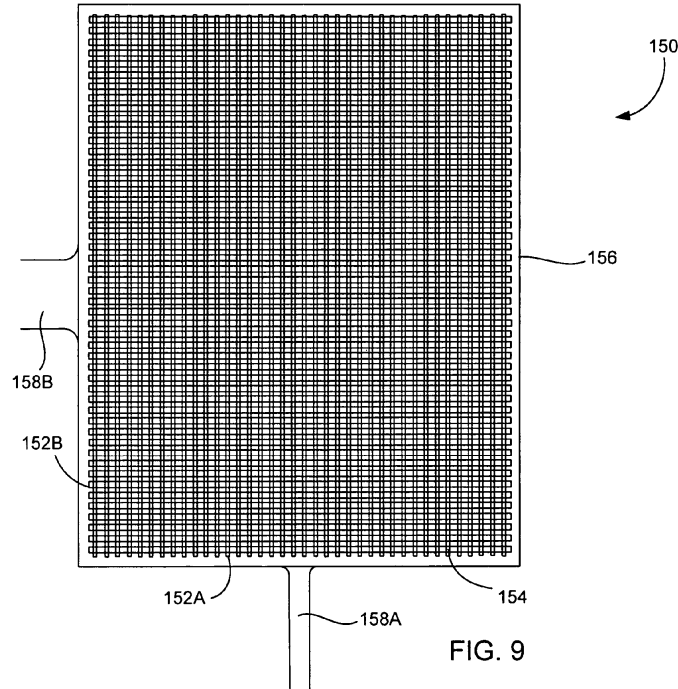

75. As shown in Figure 10 of the '607 patent, the two layers are physically separated from each other by an insulator other so as to create a weak capacitor at each crossing point of the lines. Glass members are used for each of the layers. A top, protective cover sheet is disposed over the layers of conductive lines to provide a smooth surface for an object, such as a finger tip, to slide thereon.

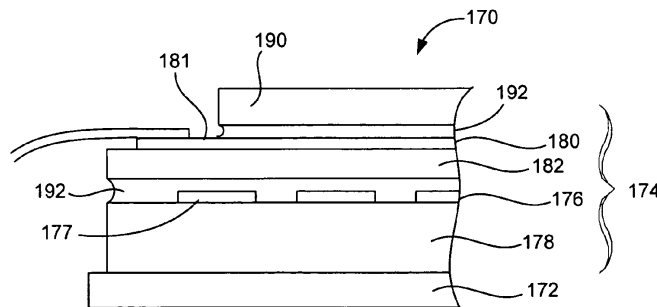

**SUBJECT TO PROTECTIVE ORDER
CONTAINS HIGHLY CONFIDENTIAL – ATTORNEYS’ EYES ONLY INFORMATION**

76. The ‘607 patent describes a self-capacitive and a mutual capacitive embodiments. The mutual capacitive embodiment is described in all the asserted claims. In this embodiment, during operation, the rows of “driving” conductive lines are charged, sequentially one at a time, while the columns of “sensing” conductive lines all sense, or measure, the change in capacitance at each intersection of the driving and sensing lines. (*See* ‘607 patent at 5:47-6:6; 9:22-65). According to the description in the ‘607 patent, this drive/sense arrangement, which was used in many prior art touchscreens, allows for the detection of multiple touch events that occur at the same time. (*Id.* at 5:1-14; 5:66-6:2).

C. The Asserted Claims

77. Apple has asserted claims 1-3, 6-8, 10 and 11 of the ‘607 patent (the "Asserted Claims") in this case. The Asserted Claims are reproduced here:

1. A touch panel comprising a transparent capacitive sensing medium configured to detect multiple touches or near touches that occur at a same time and at distinct locations in a plane of the touch panel and to produce distinct signals representative of a location of the touches on the plane of the touch panel for each of the multiple touches, wherein the transparent capacitive sensing medium comprises:
 - a first layer having a plurality of transparent first conductive lines that are electrically isolated from one another; and
 - a second layer spatially separated from the first layer and having a plurality of transparent second conductive lines that are electrically isolated from one another, the second conductive lines being positioned transverse to the first conductive lines, the intersection of transverse lines being positioned at different locations in the plane of the touch panel, each of the second conductive lines being operatively coupled to capacitive monitoring circuitry;wherein the capacitive monitoring circuitry is configured to detect changes in charge coupling between the first conductive lines and the second conductive lines.
2. The touch panel as recited in claim 1 wherein the conductive lines on each of the layers are substantially parallel to one another.
3. The touch panel as recited in claim 2 wherein the conductive lines on different layers are substantially perpendicular to one another.
6. The touch panel as recited in claim 1 wherein the conductive lines are formed from indium tin oxide (ITO).

SUBJECT TO PROTECTIVE ORDER
CONTAINS HIGHLY CONFIDENTIAL – ATTORNEYS’ EYES ONLY INFORMATION

7. The touch panel as recited in claim 1, wherein the capacitive sensing medium is a mutual capacitance sensing medium.
8. The touch panel as recited in claim 7, further comprising a virtual ground charge amplifier coupled to the touch panel for detecting the touches on the touch panel.
10. A display arrangement comprising:
 - a display having a screen for displaying a graphical user interface; and
 - a transparent touch panel allowing the screen to be viewed therethrough and capable of recognizing multiple touch events that occur at different locations on the touch panel at a same time and to output this information to a host device to form a pixilated image;
 - wherein the touch panel includes a multipoint sensing arrangement configured to simultaneously detect and monitor the touch events and a change in capacitive coupling associated with those touch events at distinct points across the touch panel; and
 - wherein the touch panel comprises:
 - a first glass member disposed over the screen of the display;
 - a first transparent conductive layer disposed over the first glass member, the first transparent conductive layer comprising a plurality of spaced apart parallel lines having the same pitch and linewidths;
 - a second glass member disposed over the first transparent conductive layer;
 - a second transparent conductive layer disposed over the second glass member, the second transparent conductive layer comprising a plurality of spaced apart parallel lines having the same pitch and linewidths, the parallel lines of the second transparent conductive layer being substantially perpendicular to the parallel lines of the first transparent conductive layer;
 - a third glass member disposed over the second transparent conductive layer; and
 - one or more sensor integrated circuits operatively coupled to the lines.
11. The display arrangement as recited in claim 10 further including dummy features disposed in the space between the parallel lines, the dummy features optically improving the visual appearance of the touch screen by more closely matching the optical index of the lines.

D. The Prosecution History

78. I have reviewed the prosecution file history (Exhibit 607-04) of the ‘607 patent.

The application that led to the ‘607 patent was rejected four times by the United States Patent and

**SUBJECT TO PROTECTIVE ORDER
CONTAINS HIGHLY CONFIDENTIAL – ATTORNEYS’ EYES ONLY INFORMATION**

Trademark Office (“USPTO”) in view of a variety of prior art references. The application was ultimately allowed on December 16, 2009.

79. I have also reviewed the prior art cited during the prosecution of the application that led to the ‘607 patent during prosecution. The USPTO did not consider certain prior art that I address in this report, and in my opinion, incorrectly evaluated certain other prior art that was cited in the prosecution file history. In addition, the USPTO did not have the benefit of the testimony of the inventors of the ‘607 patent, Steve Hotelling, Joshua A. Strickon and Brian Q. Huppi, or the testimony of Shawn P. Day, the CTO of Synaptics, Inc. and co-inventor of U.S. Patent No. 7,030,860 (“Hsu”).

IX. DISPUTED TERMS FROM THE ASSERTED CLAIMS AND THE PARTIES’ PROPOSED CONSTRUCTIONS

80. The parties disagree about only a single disputed claim term.³ I understand that the Court has already held a *Markman* hearing addressing this term and the parties are expecting a ruling shortly. Regardless, I have analyzed the validity of the ‘607 patent under both parties’ constructions.

‘607 Patent Term	Samsung’s Proposed Construction	Apple’s Proposed Construction
“glass member” (claim 10)	Plain meaning	Glass or plastic material

X. PRIOR ART WHICH INVALIDATES THE ASSERTED CLAIMS OF THE 607 PATENT

³ Although Samsung initially disputed the term “capacitive monitoring circuitry,” I understand that Samsung has dropped this claim term in order to streamline the case.

**SUBJECT TO PROTECTIVE ORDER
CONTAINS HIGHLY CONFIDENTIAL – ATTORNEYS’ EYES ONLY INFORMATION**

81. All of the limitations of the asserted claims were well known at least one year prior to the filing date of the application for the ‘607 patent, as will be come apparent from the prior art I review and discuss below.

82. It is my opinion that each of the asserted claims of the ‘607 patent are invalid due to , anticipation, derivation and/or obviousness, in light of the following prior art items.

A. Perski ‘455 Anticipates and/or Renders Obvious the Asserted Claims of the ‘607 Patent

83. U.S. Patent 7,372,455 (“Perski ‘455”), entitled “Touch Detection for a Digitizer,” to H. Perski and M. Morag, was filed on January 15, 2004, issued on May 13, 2008, and is assigned to N-Trig Ltd. Perski ‘455 claims the benefit of U.S. Provisional Pat. App. Nos. 60/446,808, filed on February 10, 2003, and 60/501,484, filed September 5, 2003. As such, Perski ‘455 qualifies as prior art to the ’607 patent under 35 U.S.C. § 102(e). In addition, the patent incorporates by reference U.S. Provisional Pat. App. No. 60/406,662, filed Aug 27, 2002, (“Perski ‘662”) and U.S. Pat. App. No. 10/649,708, filed Aug 28, 2003 (“Perski ‘708”), both of which are also assigned to N-Trig Ltd.

84. Perski ’455 is directed to “a combined touch and stylus digitizer, and more particularly, but not exclusively to adaptations for the detection of finger touch.” (*Id.* at 1:14-16). Using Perski’s digitizer, “multiple conductive objects can be detected” and the digitizer is configured “to detect more than one finger touch at the same time.” (*Id.* at 4:1-3; 14:15-19). In my opinion, Perski’s digitizer is almost identical in construction and operation to the transparent capacitive sensing medium described in the ’607 Patent. As described above, ALJ Essex, the Commission Investigative Staff, and the full Commission also agreed with this opinion. (*See* § (VI)(A) above).

SUBJECT TO PROTECTIVE ORDER
CONTAINS HIGHLY CONFIDENTIAL – ATTORNEYS’ EYES ONLY INFORMATION

85. I also understand that during the ITC investigation initiated against Motorola, Apple did not contest that Perski ‘455 did in fact disclose *almost all* of the limitations of the Asserted Claims. I understand that the only contested limitations were the multitouch limitation in each of independent claims 1 and 10. (*Id.*).

2. Analysis of the Claim Elements

- (a) **Claim [1A] - “A touch panel comprising a transparent capacitive sensing medium configured to detect multiple touches or near touches that occur at a same time and at distinct locations in a plane of the touch panel and to produce distinct signals representative of a location of the touches on the plane of the touch panel for each of the multiple touches”**

86. Perski ‘455 discloses a touch panel comprising a transparent capacitive sensing medium configured to detect multiple touches or near touches at a same time and at distinct locations in a plane of the touch panel and to produce distinct signals representative of a location of the touches on the plane of the touch panel for each of the multiple touches. For example, Perski discloses, in the Summary of the Invention, that “[p]referably, the sensor is substantially transparent and suitable for location over a display screen.” (*Id.* at 3:39-40). Figure 2 of the Perski ‘455 illustrates that the sensing medium of the sensor is a grid, described thusly: “FIG. 2 is a simplified diagram illustrating an embodiment of the present invention in which the touching finger provides a capacitive link between sensing conductors on a grid.” (*Id.* at 7:16-19).

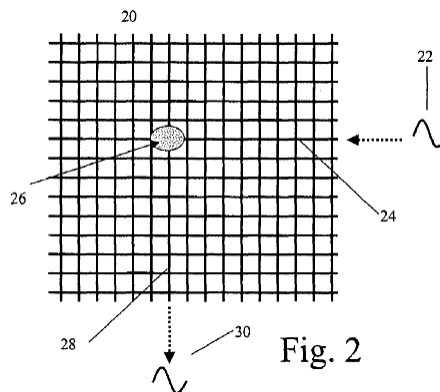

**SUBJECT TO PROTECTIVE ORDER
CONTAINS HIGHLY CONFIDENTIAL – ATTORNEYS’ EYES ONLY INFORMATION**

87. Perski ‘455 expressly discloses that the touch sensor described therein supports the detection of multiple touches or near touches at a same time and at distinct locations in a plane of the touch panel and produces distinct signals representative of a location of the touches on the plane of the touch panel for each of the multiple touches. For example, Perski ‘455 describes two different detection methods. In the second method, “[t]he goal of the finger detection algorithm...is to recognize all of the sensor matrix junctions that transfer signals due to external finger touch. It should be noted that this algorithm is preferably able to detect more than one finger touch at the same time.” (*Id.* at 14:15-19). It is therefore my opinion that Perski ‘455 discloses this limitation.

(b) Claim [1B] - “wherein the transparent capacitive sensing medium comprises: a first layer having a plurality of transparent first conductive lines that are electrically isolated from one another”

88. Perski ‘455 expressly incorporates by reference Perski ‘662 and Perski ‘708 for additional information regarding the construction of its sensor. Figure 3 of Perski ‘622 shows a transparent capacitive sensing medium with a first layer having a plurality of transparent first conductive lines that are electrically isolated from one another. (Perski ‘662 at 4; Figure 3).

89. For example, Perski ‘662 discloses that “the sensor is a grid of conductive lines made of conductive polymers patterned on a PET foil. The grid is made of two layers, which are electrically separated from each other. One of the layers contains a set of parallel conductors. The other layer contains a set of parallel conductors orthogonal to the set of the first layer.” (*Id.* at 4). The conductors can be made from “transparent conductive materials such as ITO.” (*Id.* at 5).

90. It is therefore my opinion that Perski ‘455 discloses this limitation.

**SUBJECT TO PROTECTIVE ORDER
CONTAINS HIGHLY CONFIDENTIAL – ATTORNEYS’ EYES ONLY INFORMATION**

(c) Claim [1C] – “and a second layer spatially separated from the first layer and having a plurality of transparent second conductive lines that are electrically isolated from one another”

91. Figure 3 of Perski ‘662 shows a transparent capacitive sensing medium with a first layer having a plurality of transparent first conductive lines that are electrically isolated from one another, and a second layer spatially separated from the first layer and having a plurality of transparent second conductive lines that are electrically isolated from one another, the second conductive lines being positioned transverse to the first conductive lines, the second conductive lines being positioned at different locations in the plane of the touch panel.

92. For example, Figure 3 of Perski ‘662 shows a “vertical pattern” of conductive lines, a “horizontal pattern” of conductive lines, and a “PET” layer which spatially separates the vertical and horizontal patterns. (*See* Perski ‘662 at 4-6). The vertical and horizontal patterns are transverse to the horizontal pattern, and each pattern includes several parallel conductive lines. (*Id.*). In connection with Figure 3, Perski ‘662 also discloses that “[t]he grid is made of two layers, which are electrically separated from each other.” (*Id* at 4). It is therefore my opinion that Perski ‘455 discloses this limitation.

(d) Claim [1D] – “the second conductive lines being positioned transverse to the first conductive lines”

93. As shown Figure 2 of Perski ‘662, the vertical pattern and horizontal pattern form a “matrix” or grid of transparent conductors. Perski explains that “[t]he grid is made of two layers, which are electrically separated from each other. One of the layers contains a set of parallel conductors. The other layer contains a set of parallel conductors orthogonal to the set of the first layer.” (*Id* at 4).

94. It is therefore my opinion that Perski ‘455 discloses this limitation.

SUBJECT TO PROTECTIVE ORDER
CONTAINS HIGHLY CONFIDENTIAL – ATTORNEYS’ EYES ONLY INFORMATION

- (e) **Claim [1E] – “ the intersection of transverse lines being positioned at different locations in the plane of the touch panel, each of the second conductive lines being operatively coupled to capacitive monitoring circuitry”**

95. The intersection of the horizontal and vertical patterns of conductive lines are positioned at different locations in the plane of the touch panel. For example, as shown in Figure 3 of Perski ‘662, the two conductive patterns form an (X, Y) grid or matrix where the intersection of the horizontal and parallel patterns are regularly spaced over the entire plane of the touch panel. (*Id.*) The conductors “are set in an arrangement or pattern over the sensor, most often as a grid which extends over a surface such as an electronic screen for which touch sensing is required.” (Perski ‘455 at 9:19-24).

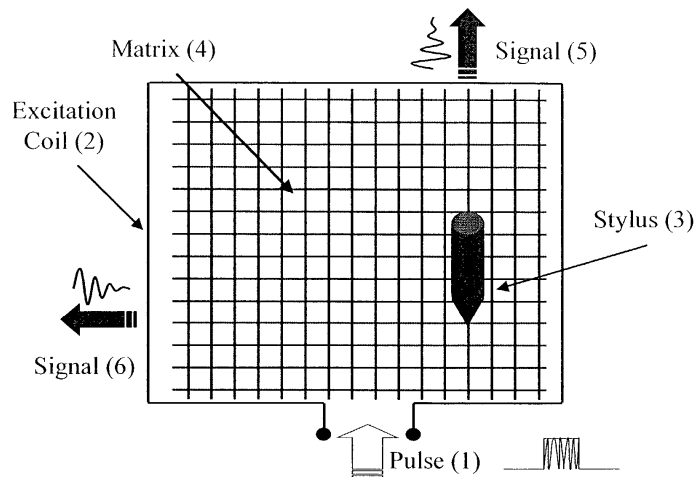

Figure 2: physical principle

96. Perski ‘455 describes the intersection points of the horizontal and vertical conductors “junctions.” (Perski ‘455 13:30-43; 13:65-14:19). At these junctions, a weak capacitor is formed. The finger detection algorithm described in Perski ‘455 measures the capacitance at each of these junctions, which are positioned at different locations across the touch panel and cover the entire touch panel. (*Id.* at 9:19-24; 13:65-14:19).

SUBJECT TO PROTECTIVE ORDER
CONTAINS HIGHLY CONFIDENTIAL – ATTORNEYS’ EYES ONLY INFORMATION

97. Perski ‘455 also describes a “detector” that is responsible for “pick[ing] up the output from the conductors.” (*Id.* at 9:24-25). The detector is made up of a front end unit and a digital unit. The conductive lines are directly connected to the inputs of differential amplifiers in the front end unit. (Perski ‘662 at 6-8).

98. It is therefore my opinion that Perski ‘455 discloses this limitation.

(f) Claim [1F] - “wherein the capacitive monitoring circuitry is configured to detect changes in the charge coupling between the first conductive lines and the second conductive lines”

99. Perski ‘455 discloses “even without the influence of an EM signal, a user’s finger adds a capacitance that connects two orthogonal lines.” (Perski ‘455 at 13:26-29). Perski goes on to explain the operation of the second embodiment circuitry, stating that “[e]ach one of the lines [referring to the orthogonal lines of the sensor matrix] can serve either for reception or injection of signals.” (*Id.* 13:67-14:3). In describing Figure 2, Perski ‘455 states that: “[a]n electric signal 22 is applied to a first conductor line 24 in the two-dimensional matrix 20. At each junction between two conductors a certain minimal amount of capacitance exists. A finger 26 touches the sensor 20 at a certain position and increases the capacitance *between the first conductor line 24 and the orthogonal conductor line 28* which happens to be at or closest to the touch position. As the signal is AC (alternating current) the signal crosses by virtue of the capacitance of the finger 26 from the first conductor 24 to the orthogonal conductor 28, and an output signal 30 may be detected.” (*Id.* at 13:33-43 (emphasis added)). As described below in connection with claim 7, this arrangement represents a typical mutual capacitance setup. (*See also id.* at 14:20-59).

100. It is therefore my opinion that Perski ‘455 discloses this limitation.

SUBJECT TO PROTECTIVE ORDER
CONTAINS HIGHLY CONFIDENTIAL – ATTORNEYS’ EYES ONLY INFORMATION

(g) Claim [2] - “The touch panel as recited in claim 1 wherein the conductive lines on each of the layers are substantially parallel to one another”

101. Perski ‘455 discloses that the conductive lines on each of the layers are substantially parallel to each other. For example, Perski states “[i]n a preferred embodiment, the sensor is a grid of conductive lines made of conductive polymers patterned on a PET foil. The grid is made of two layers, which are electrically separated from each other. One of the layers contains a set of parallel conductors. The other layer contains a set of parallel conductors orthogonal to the set of the first layer.” (Perski ‘662 at 4).

102. It is therefore my opinion that Perski ‘455 discloses this limitation.

(h) Claim [3] - “The touch panel as recited in claim 2 wherein the conductive lines on different layers are substantially perpendicular to each other”

103. Perski ‘455 discloses that the conductive lines on different layers are substantially perpendicular to each other. For example, Perski explains that “[t]he other layer contains a set of parallel conductors orthogonal to the set of the first layer.” (*Id.*). “Orthogonal” conductors are synonymous with “substantial perpendicular” conductive lines. Figure 2 of Perski ‘662 clearly shows substantially perpendicular conductive lines on the two layers.

104. It is therefore my opinion that Perski ‘455 discloses this limitation.

(i) Claim [6] - “The touch panel recited in claim 1 wherein the conductive lines are formed from indium tin oxide (ITO)”

105. Perski ‘455 disclose that the conductive lines may be formed from “transparent conductive materials” like indium tin oxide (ITO). For example, Perski ‘455 describes his sensor as: “patterned with organic conductive material on a PET foil. Organic conductive materials are basically more flexible, easier to handle and enable lower visual difference between conductive

SUBJECT TO PROTECTIVE ORDER
CONTAINS HIGHLY CONFIDENTIAL – ATTORNEYS’ EYES ONLY INFORMATION

to non-conductive areas. However, in different embodiments the present invention sensor could be implemented on other transparent conductive materials such as ITO.” (*Id* at 5).

106. It is therefore my opinion that Perski ‘455 discloses this limitation.

(j) Claim [7] - “The touch panel as recited in claim 1, wherein the capacitive sensing medium is a mutual capacitance sensing medium”

107. Perski ‘455 discloses that the capacitive sensing medium is a mutual capacitance sensing medium. In the description of Figure 2, Perski ‘455 states: “At each junction between two conductors a certain minimal amount of capacitance exists. A finger 26 touches the sensor 20 at a certain position and increases the capacitance between the first conductor line 24 and the orthogonal conductor line 28 which happens to be at or closest to the touch position. As the signal is AC, the signal crosses by virtue of the capacitance of the finger 26 from the first conductor line 24 to the orthogonal conductor 28 and an output signal 30 may be detected.” (Perski ‘455 at 13:35-43).

108. While not using the words “mutual capacitance sensing medium,” this description of the operation of the sensor illustrated in Figure 2, accompanied by the electric equivalent shown in Figure 3 is precisely the description of a mutual capacitance sensing medium as described in the ‘607 patent. For example, the ‘607 patent explains that: “In mutual capacitance, the mutual capacitance between at least first and second electrodes is measured.” (‘607 patent at 5:21-22). An inventor of the ‘607 patent, Steve Hotelling, [REDACTED]

[REDACTED] This definition was confirmed by Shawn P. Day, CTO of Synaptics, Inc., an early player in the transparent capacitive touchscreen industry. (*See* Day Dep. Tr. 25:8-13).

SUBJECT TO PROTECTIVE ORDER
CONTAINS HIGHLY CONFIDENTIAL – ATTORNEYS’ EYES ONLY INFORMATION

109. This definition and explanation is further amplified in the ‘607 patent: “In mutual capacitance, the transparent conductive medium is patterned into a group of spatially separated lines formed on two different layers. Driving lines are formed on a first layer and sensing lines are formed on a second layer. Although separated by being on different layers, the sensing lines traverse, intersect or cut across the driving lines thereby forming a capacitive coupling node.” (‘607 patent at 5:47-5:53). This is precisely the same construction and operation of the sensor described in Perski’s second embodiment. (Perski ‘455 at 13:35-14:59).

110. It is therefore my opinion that Perski ‘455 discloses this limitation.

111. Even if Perski ‘455 did not disclose a mutual capacitance sensing medium, such a sensing medium would have been obvious to one of ordinary skill in the art at the time the invention described in the ‘607 patent was made. Both self capacitive and mutual capacitive touch sensors were well-known prior to 2004 and used in many applications. In fact, Synaptics, Inc. had come up with a mutual capacitance touch sensor as early as 1993 or 1994⁴ – 10 years prior to the filing date of the ‘607 patent. (Day Dep. Tr. 28:4-9). The choice to use one form of capacitive sensing over another is merely an implementation detail. For example, Synaptics CTO Shawn Day testified:

- Q.** In your experience as an engineer, are there any major technical differences between basing a touch sensor on self-capacitance versus mutual capacitance?
- A.** Well, there is lots of little details; how you design the electronics, possibly the algorithms used to interpret the data.
- Q.** But in most cases, either self-capacitance or mutual capacitance could be used depending on the application; right?

⁴ See, e.g., U.S. Patent No. 5,305,017 to Gerpheide (filed July 13, 1992; issued April 19, 1994; priority claim to August 16, 1989).

**SUBJECT TO PROTECTIVE ORDER
CONTAINS HIGHLY CONFIDENTIAL – ATTORNEYS’ EYES ONLY INFORMATION**

- A. It depends on the application. Some may be more amenable for one versus the other type of measurement.
- Q. Okay. And in 2002, certainly, or even by 1999 [], it was certainly very well known to use either self-capacitance or mutual capacitance in a touch sensor, right?
- A. Yes, I believe it was well known.

(Day Dep. Tr. 108:12-109:11 (objections omitted)).

112. As such, the use of a mutual capacitive sensing medium is a predictable variant on other types of capacitive sensing and a matter of simple design implementation. Depending on the application for the touch sensor, one of ordinary skill in the art would be motivated to use whatever form of capacitive sensing that best suited the needs of the touch sensor application. To the extent this limitation is not expressly or inherently disclosed by Perski ‘455, it is rendered obvious by Perski ‘455 itself or Perski ‘455 in combination with U.S. Patent No. 5,305,017 to Gerpheide (“Gerpheide”). (*See* Gerpheide at 9:62-12:13 for a description of mutual capacitance operation in a ouch sensor).

(k) Claim [8] -- “The touch panel as recited in claim 7, further comprising a virtual ground charge amplifier coupled to the touch panel for detecting the touches on the touch panel”

113. [REDACTED]

[REDACTED]

[REDACTED]

[REDACTED]

[REDACTED]

[REDACTED]

[REDACTED]

SUBJECT TO PROTECTIVE ORDER
CONTAINS HIGHLY CONFIDENTIAL – ATTORNEYS’ EYES ONLY INFORMATION

114. The digitizer described in Perski ‘455 employs such operational amplifiers. (*See, e.g., id.* at Figures 5, 8, 10B, 14, 15, 16A, and 17). As discussed previously, these operational amplifiers were known to carry Miller capacitance. Perski ‘455 uses the operational amplifiers without other feedback. Thus, the Miller capacitance of the operational amplifier provides the charge feedback in the structure, producing the charge amplifier circuit shown in Figure 13 of the ‘607 patent. Furthermore, the Miller theorem states that this Miller capacitance is mathematically identical to a pair of capacitors to ground, providing a virtual ground to the charge amplifier.

115. Thus, the operational amplifier 7 shown in Figure 5 of Perski ‘455 is a virtual ground charge amplifier. One of ordinary skill in the art knows that operational amplifier 7 has Miller capacitance, which provides virtual ground charge feedback. Additional virtual grounding is provided by the capacitive coupling of the finger or touch, through the natural resistance of the body to the ground.

116. Even if Perski ‘455 did not expressly or inherently disclose a virtual ground charge amplifier, it would have been obvious to one of ordinary skill in the art to use a virtual ground charge amplifier as one of the several ways that detection of touches on the touch panel could have been performed. Indeed, Perski ‘455 acknowledges that “the prior art teaches connection of a separate charge sensor or the like to each electrode.” (Perski ‘455 at 8:26-28). One such example of such a separate charge sensor is that of Blonder et al., U.S. Patent No. 5,113,041 issued May 12, 1992 (“Blonder”). As shown in Figure 3a of Blonder, reproduced below, element 30 is a virtual ground charge amplifier coupled to the touch panel for detecting the touches on the touch panel. It would have been obvious to one of ordinary skill in the art to include the virtual ground charge amplifier of Blonder in the digitizer of Perski as a predictable

**SUBJECT TO PROTECTIVE ORDER
CONTAINS HIGHLY CONFIDENTIAL – ATTORNEYS’ EYES ONLY INFORMATION**

variant and a matter of simple design implementation in order, for example, to reduce noise from stray capacitance.

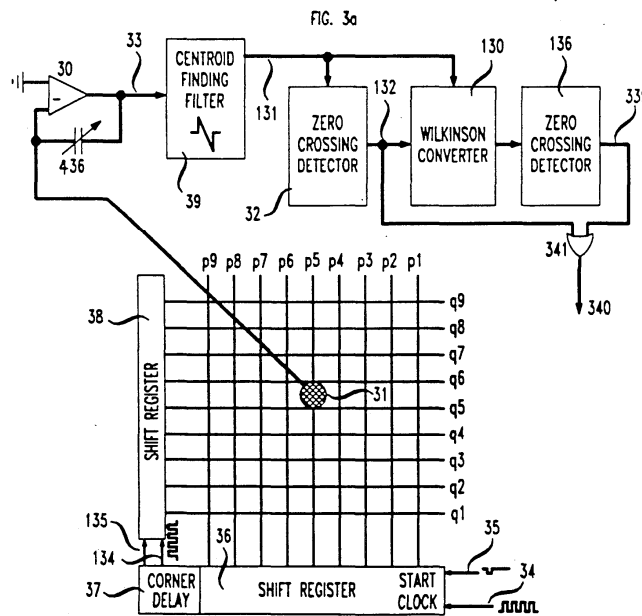

117. It is therefore my opinion that Perski ‘455 discloses this limitation.

(l) Claim [10A] – “A display arrangement having a screen for displaying a graphical user interface”

118. Perski ‘455 discloses this limitation for at least the same reasons described above in connection with claim [1A]. In addition, Perski ‘455 states that “the sensor is substantially transparent and suitable for location over a display screen.” (Perski ‘455 at 3:39-44). In addition, Perski ‘822 describes many tablet, PDAs, and flat screen displays, all of which include a graphical user interface. (Perski ‘822 at 1).

119. It is therefore my opinion that Perski ‘455 discloses this limitation.

(m) Claim [10B] -- “a transparent touch panel allowing the screen to be viewed therethrough and capable of recognizing multiple touch events that occur at different locations on the touch panel at a same time and to output this information to a host device to form a pixilated image”

SUBJECT TO PROTECTIVE ORDER
CONTAINS HIGHLY CONFIDENTIAL – ATTORNEYS’ EYES ONLY INFORMATION

120. Perski ‘455 discloses a transparent touch panel allowing the screen to be viewed therethrough and capable of recognizing multiple touch events that occur at different locations on the touch panel at a same time and to output this information to a host device to form a pixilated image for at least the same reasons described above in connection with claim [1A].

121. In addition, Perski ‘455 states that: “[t]he goal of the finger detection algorithm, in this method, is to recognize all of the sensor matrix junctions that transfer signals due to external finger touch. It should be noted that this algorithm is preferably able to detect more than one finger touch at the same time.” (*Id.* at 14:15-19). Finally, Perski ‘455 describes a “differential map” and states that the map is “includes both the magnitude and phase of the differential signals recorded for each sensor pair. Each recorded magnitude phase pair represents the display panel ‘steady noise’ of each pair of sensor conductors connected by a differential amplifier.” (*Id.* at 21:15-19). This differential map is a pixilated image formed at the host and further used by the host to calculate the actual desired signal from the detector. (*Id.* at 21:38-45).

122. It is therefore my opinion that Perski ‘455 discloses this limitation.

(n) Claim [10C] – “wherein the touch panel includes a multipoint sensing arrangement configured to simultaneously detect and monitor the touch events and a change in capacitive coupling associated with those touch events at distinct points across the touch panel”

123. Perski ‘455 discloses that its digitizer includes a multipoint sensing arrangement configured to simultaneously detect and monitor the touch events and a change in capacitive coupling associated with those touch events at distinct points across the touch panel.

124. Perski ‘455 discloses this limitation for at least the same reasons described above in connection with claim [1A].

125. It is therefore my opinion that Perski ‘455 discloses this limitation.

SUBJECT TO PROTECTIVE ORDER
CONTAINS HIGHLY CONFIDENTIAL – ATTORNEYS’ EYES ONLY INFORMATION

(o) Claim 10[D] – “wherein the touch panel comprises: a first glass member disposed over the screen of the display;

126. Perski ’455 discloses a first glass member disposed over the screen of a display under both parties’ proposed claim constructions.

(i) Invalidity under Samsung’s Proposed Construction

127. Samsung contends that the term “glass member” should be given its plain and ordinary meaning to mean “glass” as opposed to plastic materials.

128. As described above, Perski ’662 discloses an embodiment that uses “three different layers, implemented on three different foils. Two layers are used for the grid of lines, one for x axis and one for y axis, and the third layer is used for hard coating and anti glaring.” (Perski ’822 at 5). The layers may be glass or plastic. (*Id.* at 6). For example, Perski ’662 explains that the conductive patterns may be patterned on “polyester foils” or “different materials such as glass or different type of plastic foils.” (*Id.*). The various layers in one embodiment of Perski ’662 are shown below in Figure 3.

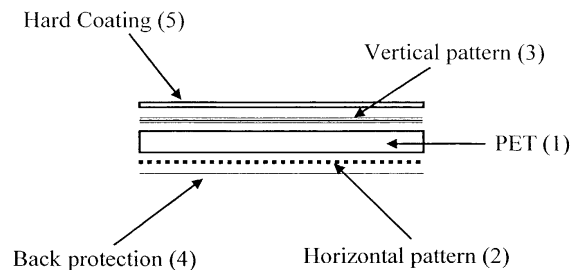

The sensor described in Perski ’455 is also designed to be positioned in front of a display. For example, Perski explains that “sensor (1), preferably transparent, is located on top of a FPD [flat panel] display.” (Perski ’662 at 4).

129. It is therefore my opinion that Perski ’455 discloses this limitation under Samsung’s claim construction.

**SUBJECT TO PROTECTIVE ORDER
CONTAINS HIGHLY CONFIDENTIAL – ATTORNEYS’ EYES ONLY INFORMATION**

(ii) Invalidity under Apple’s Proposed Construction

Apple contends that the term “glass member” should be construed to mean any glass or plastic material. As described above, the foils or layers on which the conductive patterns are deposited in Perski’s digitizer may be glass or plastic. (*Id.* at 6). As such, it is my opinion that Perski ‘455 discloses this limitation under Apple’s proposed construction.

(p) Claim [10E] – “a first transparent conductive layer disposed over the first glass member”

Perski ‘455 discloses a first transparent conductive layer disposed over the first glass member. For example, the horizontal pattern is a transparent conductive layer. (*See* analysis for claim [10D] above). As described above, the conductive horizontal and vertical patterns are patterned directly on the polyester foil, glass, or other type of plastic foil. (*Id.* at 6).

130. It is therefore my opinion that Perski ‘455 discloses this limitation.

(q) Claim [10F] – “the first transparent conductive layer comprising a plurality of spaced apart parallel lines having the same pitch and linewidths”

131. Perski ‘455 discloses this limitation for at least the same reasons described above in connection with claim [1B].

132. In addition, Perski ‘662 describes its transparent sensor as “a grid of conductive lines made of conductive polymers patterned on a PET foil. The grid is made of two layers, which are electrically separated from each other. One of the layers contains a set of parallel conductors. The other layer contains a set of parallel conductors orthogonal to the set of the first layer.” (Perski ‘662 at 4).

133. Perski ‘662 describes the conductors in more detail as “straight lines having 1 mm width, equally spaced in 4 mm interval. Larger interval between the lines could be selected in order to reduce the total number of conductors and therefore to reduce the electronic and the

SUBJECT TO PROTECTIVE ORDER
CONTAINS HIGHLY CONFIDENTIAL – ATTORNEYS’ EYES ONLY INFORMATION

price of the system. Smaller intervals could be selected to get higher resolution. Wider line width could be selected in order to reduce the resistance of a conductive line.” (*Id.* at 5). Since the line spacing is fixed at 4mm and the width of each line is fixed at 1mm, Perski ‘455 discloses that the first transparent conductive layer comprises a plurality of spaced apart parallel lines having the same pitch and linewidths.

134. It is therefore my opinion that Perski ‘455 discloses this limitation.

(r) Claim [10G] – “a second glass member disposed over the first transparent conductive layer”

135. Perski ‘455 discloses this limitation for at least the same reasons described above in connection with claim [10D] under both parties’ proposed constructions.

(i) Invalidity under Samsung’s Proposed Construction

136. As described above, the three layer embodiment described in Perski ‘662 may use glass or plastic layers. *See* analysis above with respect to claim [10D]. It is therefore my opinion that Perski ‘455 discloses this limitation under Samsung’s claim construction.

(ii) Invalidity under Apple’s Proposed Construction

137. As described above, the three layer embodiment described in Perski ‘662 may use glass or plastic layers. *See* analysis above with respect to claim [10D]. It is therefore my opinion that Perski ‘455 discloses this limitation under Apple’s claim construction.

(s) Claim [10H] – “a second transparent conductive layer disposed over the second glass member

Perski ‘455 discloses a second transparent conductive layer disposed over the second glass member. For example, the vertical pattern is a transparent conductive layer. (*See* claim [10D] above). As described above, the conductive horizontal and vertical patterns are patterned directly on the polyester foil, glass, or other type of plastic foil. (*Id.* at 6).

138. It is therefore my opinion that Perski ‘455 discloses this limitation.

**SUBJECT TO PROTECTIVE ORDER
CONTAINS HIGHLY CONFIDENTIAL – ATTORNEYS’ EYES ONLY INFORMATION**

- (t) Claim [10I] – “the second transparent conductive member comprising a plurality of spaced apart parallel lines having the same pitch and linewidths”**

139. Perski ‘455 discloses this limitation for at least the same reasons described above in connection with claim [10F].

- (u) Claim [10J] – “the parallel lines of the second transparent conductive layer being substantially perpendicular to the parallel lines of the first transparent conductive layer”**

140. Perski ‘455 discloses this limitation for at least the same reasons described above in connection with claim [3].

141. For example, Perski ‘662 describes the sensor as “a grid of conductive lines made of conductive polymers patterned on a PET foil. The grid is made of two layers, which are electrically separated from each other. One of the layers contains a set of parallel conductors. The other layer contains a set of parallel conductors orthogonal to the set of the first layer.” (*Id.* at 4).

142. It is therefore my opinion that Perski ‘455 discloses this limitation.

- (v) Claim [10K] -- “a third glass member disposed over the second conductive layer”**

143. Perski discloses a third glass member disposed over the second conductive layer under both parties’ proposed constructions.

- (i) Invalidity under Samsung’s Proposed Construction**

144. For example, Perski ‘662 explains that the third layer in the three layer embodiment “is used for hard coating and anti glaring.” This third layer, like the other two layers, can be made from a variety of materials, including glass or plastic. (*Id.* at 5-6).

145. It is therefore my opinion that Perski ‘665 discloses this limitation under Samsung’s claim construction.

(ii) Invalidity under Apple’s Proposed Construction

146. As explained above, Perski ‘662 explains that the third layer in the three layer embodiment “is used for hard coating and anti glaring.” This third layer, like the other two layers, can be made from a variety of materials, including glass or plastic. (*Id.* at 5-6).

147. It is therefore my opinion that Perski ‘455 discloses this limitation under Apple’s claim construction.

(w) Claim [10L] – “one or more sensor integrated circuits operatively coupled to the lines”

148. Perski ‘455 discloses one or more sensor integrated circuits operatively coupled to the lines. In describing the elements of Figure 1, Perski ‘662 states: “Analog front-end ASICs [Application Specific Integrated Circuits] are preferably mounted on the frame of the sensor. Each front-end receive very low signal coming out of the sensor conductors.” (*Id.* at 4).

149. Perski ‘455 also describes a “detector” that is responsible for “pick[ing] up the output from the conductors.” (*Id.* at 9:24-25). The detector is made up of a front end unit and a digital unit. The conductive lines are directly connected to the inputs of differential amplifiers in the front end unit. (Perski ‘662 at 6-8).

150. It is therefore my opinion that Perski ‘455 discloses this limitation.

(x) Claim [11] – “The display arrangement as recited in claim 10 further including dummy features disposed in the space between the parallel lines, the dummy features optically improving the visual appearance of the touch screen by more closely matching the optical index of the lines”

151. Perski ‘455 discloses dummy features disposed in the space between the parallel lines, the dummy features optically improving the visual appearance of the touch screen by more closely matching the optical index of the lines.

**SUBJECT TO PROTECTIVE ORDER
CONTAINS HIGHLY CONFIDENTIAL – ATTORNEYS’ EYES ONLY INFORMATION**

152. For example, as described in both the ‘607 patent and Perski ‘455, it is important “to enable minimum visual difference between conductive to non-conductive sensor areas” of the sensor so that the user of the sensor can see the underlying display as if there were no touch sensor mounted on top of it. (*Id.* at 5).

153. Perski ‘662 addresses this problem by including “dummy areas” of conductive material. These areas are made of the same conductive material as the conductive patterns, but have been treated or passivated in order to increase their resistance. As explained by Perski ‘662: “the patterning of the transparent sensor can be implemented either by printing conductive material in conductive areas or by removing conductive material from non-conductive. Both ways are supported and can be implemented in the present invention. One advantage of the above method is the practically infinite resistance between the conductors. A disadvantage of both methods is a relatively noticeable visual difference between the conductive and non-conductive areas. It is a general object of the present invention to enable minimum visual difference between conductive to non-conductive sensor areas. Therefore, in a preferred embodiment, the non-conductive areas are made of conductive materials which are treated in a special process that increases their resistance.” (*Id.*). This special process creates the dummy areas in the space between the parallel lines by optically improving the visual appearance of the touch screen by more closely matching the optical index of the lines.

154. It is therefore my opinion that Perski ‘455 discloses this limitation.

155. To the extent Perski ‘455 does not expressly or inherently disclose the claimed dummy features, the use of such features would have been obvious to one of ordinary skill in the art as a predictable variant and a matter of simple implementation design. Perski ‘455 clearly contemplates a transparent sensor in the form of a touchscreen, so it would have been obvious to

**SUBJECT TO PROTECTIVE ORDER
CONTAINS HIGHLY CONFIDENTIAL – ATTORNEYS’ EYES ONLY INFORMATION**

one of ordinary skill in the art to incorporate “dummy features” that optically improve the visual appearance of the touchscreen by more closely matching the optical index of the lines, as taught by U.S. Patent No. 7,292,229 to Morag (“Morag”) (*see, e.g.*, Morag at 12:64-13:32) or U.S. Patent No. 7,129,935 to Mackey (“Mackey”) (*see, e.g.*, Mackey at 8:17-39), in order to reduce the visual differences between the conducting and non-conducting areas and create a transparent touch screen with little or no visual distortions.

3. The ‘607 Patent is Invalid in View of Perski ‘455

156. I have considered and compared asserted claims of the ‘607 patent to the claims and specification of Perski ‘455, as described above. It is my opinion that Perski ‘455 anticipates claims 1-3, 6-8,10 and 11 of the ‘607 patent. My opinions are supported by Exhibit 607-05, which is a claim chart that shows how Perski ‘455 discloses the limitations of the asserted claims in more detail.

B. Rekimoto Anticipates and/or Renders Obvious the Asserted Claims of the ‘607 Patent

157. Japanese Published Patent Application P2002-342033A to J. Rekimoto (“Rekimoto”), was published on November 29, 2002, and is assigned to Sony Corporation Computer Science Research Center. Rekimoto qualifies as prior art to the ‘607 patent under 35 U.S.C. § 102(b).

158. Rekimoto describes “a user input device for inputting operations, commands and the like to a computer, and in particular relates to a user input device with which object operations, commands and the like are directly input to a computer using a user’s fingertip.” (Rekimoto ¶ 0001). The input device supports the detection of multiple points of contact (e.g., finger touches) using a mutual capacitance sensing arrangement. (Rekimoto ¶¶ 0014; 0056, 0057).

2. Analysis of the Claim Elements

- (a) **Claim [1A] - “A touch panel comprising a transparent capacitive sensing medium configured to detect multiple touches or near touches that occur at a same time and at distinct locations in a plane of the touch panel and to produce distinct signals representative of a location of the touches on the plane of the touch panel for each of the multiple touches”**

159. Rekimoto discloses a touch panel comprising a transparent capacitive sensing medium configured to detect multiple touches or near touches that occur at a same time and at distinct locations in a plane of the touch panel and to produce distinct signals representative of a location of the touches on the plane of the touch panel for each of the multiple touches.

160. For example, with Rekimoto’s input device “it is possible to recognize two or more points of information, the shape of proximate objects, information on the distance to an object and the like.” (Id. ¶ [0014]). Figure 7, below, shows three contact points on the touch panel at the same time and at distinct locations.

[FIG. 7]

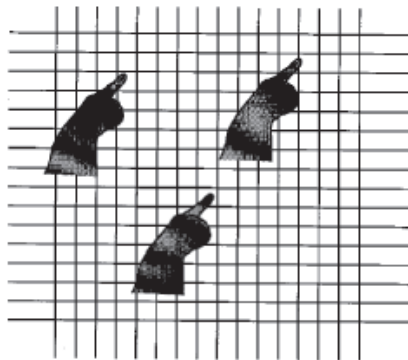

161. According to Rekimoto, “[t]hese [touch points] can be independently recognized at the points of intersection where the user fingertip[s] are proximate. Consequently, it is possible to receive simultaneous input from a plurality of users using one single user input device.” (Id. ¶ [0057]).

**SUBJECT TO PROTECTIVE ORDER
CONTAINS HIGHLY CONFIDENTIAL – ATTORNEYS’ EYES ONLY INFORMATION**

162. Like the touch sensor described in Perski ‘455, Rekimoto’s input device utilizes a grid or matrix of transmission electrodes and reception electrodes, which correspond to drive and sense lines, respectively. (Id. ¶ [0015]). At the intersection of each transmitter and reception electrode, a “virtual capacitor” is created. (Id. ¶ [0016], [0022], [0040]-[0044]).

163. As explained in Rekimoto and shown in Figure 1: “The noncontact user input device 1 according to this mode of embodiment is such that the points of intersection between the transmission electrodes 11-1... and the reception electrodes 15-1... are arrayed in an M x N matrix in the user input area. Furthermore, by virtue of a constitution such as shown in Fig. 1, it is possible to independently pick up detection values from points of intersection by independently driving the points of intersection between the electrodes.” Id. ¶ [0056].

164. Figure 9 of Rekimoto, reproduced below, shows a transparent input device adapted to be united with a display device, such as an LCD or organic LED. (Id. at [0024], [0063]). The input device is overlaid on the display to create a user input device with integrated display. A user can then perform input operations “without removing their line of sight from the display screen.” (Id. at [0062]).

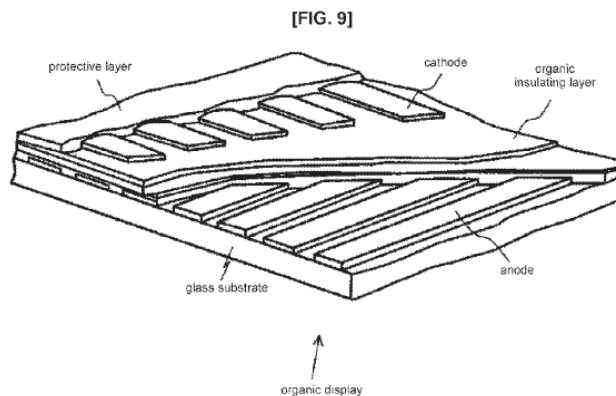

165. It is therefore my opinion that Rekimoto discloses this limitation.

(b) Claim [1B] - “wherein the transparent capacitive sensing medium comprises: a first layer having a plurality of

**SUBJECT TO PROTECTIVE ORDER
CONTAINS HIGHLY CONFIDENTIAL – ATTORNEYS’ EYES ONLY INFORMATION**

transparent first conductive lines that are electrically isolated from one another”

166. Rekimoto discloses this limitation for at least the same reasons described above in connection with claim [1A].

167. It is therefore my opinion that Rekimoto discloses this limitation.

(c) Claim [1C] – “and a second layer spatially separated from the first layer and having a plurality of transparent second conductive lines that are electrically isolated from one another”

168. Rekimoto discloses this limitation for at least the same reasons described above in connection with claim [1A].

169. In addition, Rekimoto states that “the reception electrodes have points of intersection with the [transmission] electrodes, but these electrodes do not contact each other at these points of intersection. In other words, a circuit equivalent to a capacitor that stores electrical charge is substantially formed at each intersection between the electrodes.” (Id. ¶ [0031]). In order to act as a virtual capacitor, the reception electrodes are spatially separated from the reception electrodes. (*Id.*).

170. It is therefore my opinion that Rekimoto discloses this limitation.

(d) Claim [1D] – “the second conductive lines being positioned transverse to the first conductive lines”

171. Rekimoto discloses this limitation for at least the same reasons described above in connection with claim [1A].

172. The transmission electrodes are positioned transverse to the reception electrodes in Rekimoto’s input device. For example, Rekimoto explains that “the transmission electrodes 11-1, 11-2, ..., 11-m are arrayed substantially parallel, while the reception electrodes 15-1, 15-2, ..., 15-n are arrayed in a direction orthogonal to the transmission electrodes 11-1..., and the user

**SUBJECT TO PROTECTIVE ORDER
CONTAINS HIGHLY CONFIDENTIAL – ATTORNEYS’ EYES ONLY INFORMATION**

input area is a substantially planar area in which the electrodes are combined with each other, in a uniform manner, at the nodes of the lattice.” (Id. ¶ [0033]).

173. It is therefore my opinion that Rekimoto discloses this limitation.

(e) Claim [1E] – “the intersection of transverse lines being positioned at different locations in the plane of the touch panel, each of the second conductive lines being operatively coupled to capacitive monitoring circuitry”

174. Rekimoto discloses this limitation for at least the same reasons described above in connection with claim [1A].

175. Rekimoto’s transmission lines are driven by an AC current, while the reception lines are operatively coupled to capacitive monitoring circuitry. For example, Rekimoto states: “The transmitter may apply AC current to the transmission electrodes while scanning. Then, the noncontact user input device may be further provided with a signal processing unit, which detects the input position by way of the positional relationship between the transmission electrode that transmitted the AC current and the reception electrode that received the AC current.” (Id. at [0021]).

176. The reception electrodes are connected to a capacitive monitoring circuitry including a processor in order to detect user input on the input device. Rekimoto explains that “by performing predetermined computational processing of the A/D converted output signals from the reception electrodes 15-1... with processor 20, two-dimensional user input can be detected via the user input area.” (Id. ¶ [0032]).

177. It is therefore my opinion that Rekimoto discloses this limitation.

(f) Claim [1F] - “wherein the capacitive monitoring circuitry is configured to detect changes in the charge coupling between the first conductive lines and the second conductive lines”

**SUBJECT TO PROTECTIVE ORDER
CONTAINS HIGHLY CONFIDENTIAL – ATTORNEYS’ EYES ONLY INFORMATION**

178. Rekimoto utilizes a classic drive/sense arrangement where changes in charge coupling are detected between the transmission electrodes and the reception electrodes.

179. Rekimoto explains this arrangement in connection with “virtual capacitors” as follows: “The signal processing unit utilizes the difference between the capacitance of the first virtual capacitor that is formed at the point of intersection between the transmission electrode and the reception electrode and the capacitance of the second virtual capacitor that is formed in response to an electroconductive object such a user’s fingertip having approached [the] point of intersection between [the] transmission electrode and [the] reception electrode, so as to detect the electroconductive object having approached.” (Id. ¶ [0022]). Rekimoto explains the capacitive coupling between the transmission electrodes and the reception electrodes in more detail in ¶ [0036].

180. It is therefore my opinion that Rekimoto discloses this limitation.

(g) Claim [2] - “The touch panel as recited in claim 1 wherein the conductive lines on each of the layers are substantially parallel to one another”

181. Rekimoto discloses that the conductive lines on each of the layers are substantially parallel to one another. Rekimoto states: “In the illustrated example, the transmission electrodes 11-1, 11-2, ..., 11-m are arrayed substantially parallel, while the reception electrodes 15-1, 15-2, ..., 15-n are arrayed in a direction orthogonal to the transmission electrodes 11-1..., and the user input area is a substantially planar area in which the electrodes are combined with each other, in a uniform manner, at the nodes of the lattice.” (Id. ¶ [0033]).

182. It is therefore my opinion that Rekimoto discloses this limitation.

(h) Claim [3] - “The touch panel as recited in claim 2 wherein the conductive lines on different layers are substantially perpendicular to each other”

**SUBJECT TO PROTECTIVE ORDER
CONTAINS HIGHLY CONFIDENTIAL – ATTORNEYS’ EYES ONLY INFORMATION**

183. Rekimoto discloses this limitation for at least the same reasons described above in connection with claim [2].

184. It is therefore my opinion that Rekimoto discloses this limitation.

(i) Claim [6] - “The touch panel recited in claim 1 wherein the conductive lines are formed from indium tin oxide (ITO)”

185. [REDACTED]

[REDACTED]

[REDACTED]

[REDACTED]

[REDACTED]

[REDACTED]

[REDACTED]

[REDACTED]

[REDACTED]

[REDACTED]

[REDACTED]

[REDACTED]

186. It is therefore my opinion that Rekimoto renders this claim obvious by itself or in combination with Perski ‘455 or Smartskin.

(j) Claim [7] - “The touch panel as recited in claim 1, wherein the capacitive sensing medium is a mutual capacitance sensing medium”

187. Rekimoto discloses a mutual capacitance sensing medium. For example, Rekimoto states: “The signal processing unit utilizes the difference between the capacitance of the first virtual capacitor that is formed at the point of intersection between the transmission electrode and the reception electrode and the capacitance of the second virtual capacitor that is

**SUBJECT TO PROTECTIVE ORDER
CONTAINS HIGHLY CONFIDENTIAL – ATTORNEYS’ EYES ONLY INFORMATION**

formed in response to an electroconductive object such a user’s fingertip having approached [the] point of intersection between [the] transmission electrode and [the] reception electrode, so as to detect the electroconductive object having approached.” Id. ¶ [0022]. A sending medium that measures the capacitance between two electrodes is a mutual capacitance sensing medium

188. While not using the words “mutual capacitance sensing medium,” this description of the operation of the input device of Rekimoto is precisely the description of a mutual capacitance sensing medium as described in the ‘607 patent. *See* the discussion above in § (X)(A)(1)(j) in connection with claim [7] of Perski ‘455.

189. It is therefore my opinion that Rekimoto discloses this limitation.

190. Even if Rekimoto did not disclose a mutual capacitance sensing medium, such a sensing medium would have been obvious to one of ordinary skill in the art at the time the invention described in the ‘607 patent was made. *See* § (X)(A)(1)(j) above.

(k) Claim [8] -- “The touch panel as recited in claim 7, further comprising a virtual ground charge amplifier coupled to the touch panel for detecting the touches on the touch panel”

191. [REDACTED]

[REDACTED]

[REDACTED]

[REDACTED]

[REDACTED]

[REDACTED]

[REDACTED]

192. The touch sensor described by Rekimoto employs such operational amplifiers. (*See, e.g., id.* at Figure 1). As discussed previously, these operational amplifiers were known to

SUBJECT TO PROTECTIVE ORDER
CONTAINS HIGHLY CONFIDENTIAL – ATTORNEYS’ EYES ONLY INFORMATION

carry Miller capacitance. Rekimoto uses the operational amplifiers without other feedback.

Thus, the Miller capacitance of the operational amplifier provides the charge feedback in the structure, producing the charge amplifier circuit shown in Figure 13 of the ‘607 patent.

Furthermore, the Miller theorem states that this Miller capacitance is mathematically identical to a pair of capacitors to ground, providing a virtual ground to the charge amplifier.

193. Thus, the operational amplifier 16B shown in Figure 1 of Rekimoto is a virtual ground charge amplifier. One of ordinary skill in the art knows that operational amplifier 16B has Miller capacitance, which provides virtual ground charge feedback. Additional virtual grounding is provided by the capacitive coupling of the finger or touch, through the natural resistance of the body to the ground.

194. Even if Rekimoto did not expressly or inherently disclose a virtual ground charge amplifier, it would have been obvious to one of ordinary skill in the art to use a virtual ground charge amplifier as one of the several ways that detection of touches on the touch panel could have been performed.

195. Rekimoto clearly understands the importance of the rejection of parasitic or stray capacitance in processing the signals from the touch panel, which is the most significant feature of the virtual ground charge amplifier of the ‘607 patent. One such example of a virtual ground charge amplifier is that of Blonder et al., U.S. Patent No. 5,113,041 issued May 12, 1992 (“Blonder”). As shown in Figure 3a of Blonder, reproduced below, element 30 is a virtual ground charge amplifier coupled to the touch panel for detecting the touches on the touch panel. It would have been obvious to one of ordinary skill in the art to include the virtual ground charge amplifier of Blonder in the input device of Rekimoto as a predictable variant and a matter of simple design implementation in order, e.g., to reduce noise from stray capacitance.

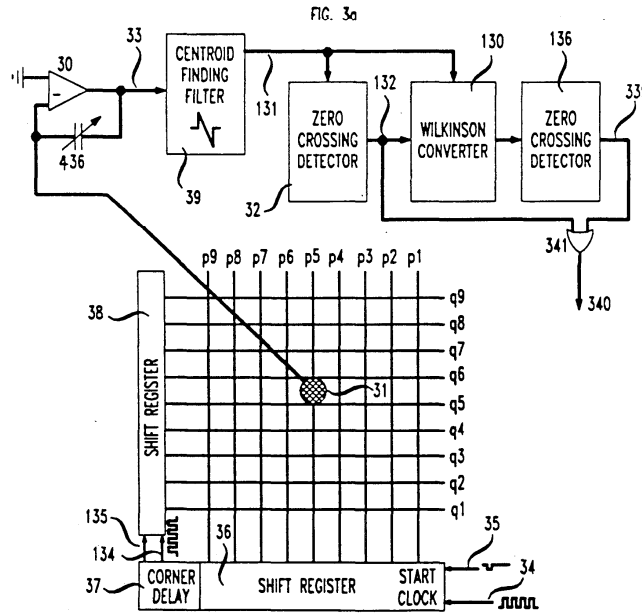

196. It is therefore my opinion that Rekimoto discloses this limitation.

(l) Claim [10A] – “A display arrangement having a screen for displaying a graphical user interface”

197. Rekimoto discloses a display arrangement having a screen for displaying a graphical user interface. Rekimoto states: “By overlaying the user input device 1 on a flat display such as a liquid crystal display (LCD) or an organic EL, it is possible to constitute a user input device having an integrated display. With such a user input device, the user can easily and intuitively perform command input to the computer while being guided by the content of GUI screens that are output on the display.” (Id. at ¶ [0062]).

198. It is therefore my opinion that Rekimoto discloses this limitation

(m) Claim [10B] -- “a transparent touch panel allowing the screen to be viewed therethrough and capable of recognizing multiple touch events that occur at different locations on the touch panel at a same time and to output this information to a host device to form a pixilated image”

199. Rekimoto discloses this limitation for at least the same reasons described above in connection with claims [1A] and [1E].

**SUBJECT TO PROTECTIVE ORDER
CONTAINS HIGHLY CONFIDENTIAL – ATTORNEYS’ EYES ONLY INFORMATION**

200. Rekimoto also states: “Furthermore, by virtue of the present invention, an excellent noncontact type user input device can be provided, with which it is possible to recognize two or more points of information, the shape of a proximate object, information on distance to the object, and the like. (Id. at ¶ [0072]). In order to recognize “two or more points of information” and the shape of a “proximate object,” this indicates that the response from all sensing nodes are mapped in the digital processing unit. This conclusion is further supported by the statement of Rekimoto: “By tracking the points of intersection between the transmission electrodes and the reception electrodes at which input positions have been detected, it is possible to measure the contour of a proximate object. In other words, the noncontact user input device can not just simply detect when an object such as a user’s fingertip has approached, but also recognize the shape of the object.” (Id. at ¶ [0074]).

201. It is therefore my opinion that Rekimoto discloses this limitation.

- (n) **Claim [10C] – “wherein the touch panel includes a multipoint sensing arrangement configured to simultaneously detect and monitor the touch events and a change in capacitive coupling associated with those touch events at distinct points across the touch panel”**

202. Rekimoto discloses that its input device includes a multipoint sensing arrangement configured to simultaneously detect and monitor the touch events and a change in capacitive coupling associated with those touch events at distinct points across the touch panel.

203. Rekimoto discloses this limitation for at least the same reasons described above in connection with claim [1A].

204. It is therefore my opinion that Rekimoto discloses this limitation.

- (o) **Claim 10[D] – “wherein the touch panel comprises: a first glass member disposed over the screen of the display;**

Rekimoto discloses a first glass member disposed over the screen of a display under both

party’s proposed claim constructions.

(i) Invalidity under Samsung’s Proposed Construction

Samsung contends that “glass member” should be given its plain and ordinary meaning to mean “glass” as opposed to plastic materials.

205. As shown in Figure 9 of Rekimoto, there is a “glass substrate” positioned over the organic display. (*Id.* at [0063]-[0064]). Rekimoto’s transparent input device for use in front of a display device uses two electrode layers that are stacked on top of one another, with an insulating layer in between and a glass substrate underneath. (*Id.* at [0064]). A protective layer is disposed on top of the input device, as shown in Figure 9. The glass substrate is therefore the first glass member disposed over the screen of the display.

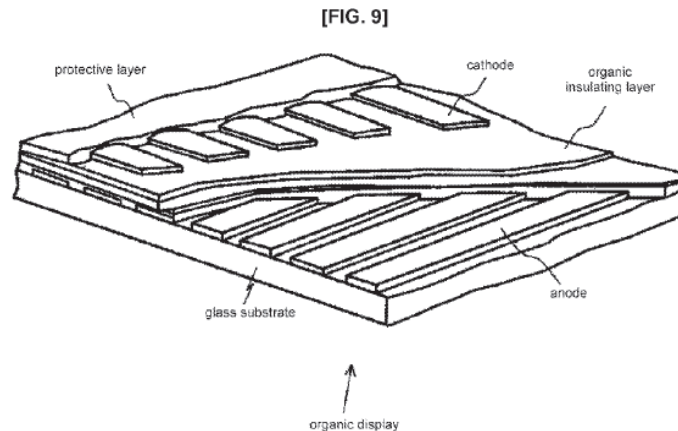

206. It is therefore my opinion that Rekimoto discloses this limitation under Samsung’s claim construction.

(ii) Invalidity under Apple’s Proposed Construction

Apple contends that “glass member” should be construed to include any glass or plastic material.

Because the “glass substrate” described above is a type of glass, it is my opinion that Rekimoto discloses this limitation under Apple’s proposed construction.

**SUBJECT TO PROTECTIVE ORDER
CONTAINS HIGHLY CONFIDENTIAL – ATTORNEYS’ EYES ONLY INFORMATION**

(p) Claim [10E] – “a first transparent conductive layer disposed over the first glass member”

207. As described above and shown in Figure 9, Rekimoto’s transparent input device for use in front of a display device uses two electrode layers that are stacked on top of one another, with an insulating layer in between. (*Id.* at [0064]). The electrode layer on the bottom of the stack is a first transparent conductive layer disposed over the first glass member.

208. It is therefore my opinion that Rekimoto discloses this limitation.

(q) Claim [10F] – “the first transparent conductive layer comprising a plurality of spaced apart parallel lines having the same pitch and linewidths”

209. Rekimoto discloses that the first transparent conductive layer comprises a plurality of spaced apart parallel lines having the same pitch and linewidths. *See* claims [1A] and [1B].

210. It is therefore my opinion that Rekimoto discloses this limitation.

(r) Claim [10G] – “a second glass member disposed over the first transparent conductive layer”

211. Rekimoto discloses this limitation under both parties’ proposed constructions for at least the same reasons described above in connection with claim [10D].

(i) Invalidity under Samsung’s Proposed Construction

212. As described above, Rekimoto’s transparent input device for use in front of a display device uses two electrode layers that are stacked on top of one another, with an insulating layer in between and a glass substrate underneath. (*Id.* at [0064]). A protective layer is disposed on top of the input device, as shown in Figure 9.

213. To the extent the organic insulating layer is not expressly or inherently made of glass, the use of a glass as the organic insulating layer would have been a predictable variant. Glass, as a transparent dielectric, is widely used in touchscreen displays. It would have been

**SUBJECT TO PROTECTIVE ORDER
CONTAINS HIGHLY CONFIDENTIAL – ATTORNEYS’ EYES ONLY INFORMATION**

obvious, therefore, to use a glass member as the insulating layer, as taught by Perski '455, in order to sufficiently shield the cathode layer from the anode layer and provide a support for the transmission electrodes.

214. It is therefore my opinion that Rekimoto discloses this limitation or at least renders it obvious.

(ii) Invalidity under Apple’s Proposed Construction

215. Apple contends that “glass member” should be construed to mean any glass or plastic material.

216. As described above, the organic insulating layer (whether it is plastic or glass) is a second glass member disposed over the first transparent conductive layer, as construed using Apple’s proposed construction. It is therefore my opinion that Rekimoto discloses this limitation under Apple’s claim construction.

(s) Claim [10H] – “a second transparent conductive layer disposed over the second glass member

217. As described above and shown in Figure 9, Rekimoto’s transparent input device for use in front of a display device uses two electrode layers that are stacked on top of one another, with an insulating layer in between. (*Id.* at [0064]). The electrode layer staked on top is a second transparent conductive layer disposed over the second glass member.

218. It is therefore my opinion that Rekimoto discloses this limitation.

(t) Claim [10I] – “the second transparent conductive member comprising a plurality of spaced apart parallel lines having the same pitch and linewidths”

219. Rekimoto discloses that the first transparent conductive layer comprises a plurality of spaced apart parallel lines having the same pitch and linewidths. *See* claim [1A] and [1B].

SUBJECT TO PROTECTIVE ORDER
CONTAINS HIGHLY CONFIDENTIAL – ATTORNEYS’ EYES ONLY INFORMATION

220. It is therefore my opinion that Rekimoto discloses this limitation.

(u) Claim [10J] – “the parallel lines of the second transparent conductive layer being substantially perpendicular to the parallel lines of the first transparent conductive layer”

221. Rekimoto defines the arrangement of the conductive lines by stating: “In the illustrated example, the transmission electrodes 11-1, 11-2, ..., 11-m are arrayed substantially parallel, while the reception electrodes 15-1, 15-2, ..., 15-n are arrayed in a direction orthogonal to the transmission electrodes 11-1..., and the user input area is a substantially planar area in which the electrodes are combined with each other, in a uniform manner, at the nodes of the lattice.” (Id. ¶ [0033]).

222. It is therefore my opinion that Rekimoto discloses this limitation.

(v) Claim [10K] -- “a third glass member disposed over the second conductive layer”

223. Perski discloses a third glass member disposed over the second conductive layer under both parties’ proposed constructions.

224. As shown in Figure 9 of Rekimoto, there is a “protective layer” positioned over the two stacked electrode layers. (*Id.* at [0064]).

(i) Invalidity under Samsung’s Proposed Construction

225. As described above, Rekimoto’s transparent input device for use in front of a display device uses two electrode layers that are stacked on top of one another, with an insulating layer in between and a glass substrate underneath. (*Id.* at [0064]). A protective layer is disposed on top of the input device, as shown in Figure 9.

226. To the extent the protective layer is expressly or inherently made of glass, the use of glass for the protective layer would have been a predictable variant. Glass, as a transparent dielectric, is widely used in touchscreen displays. It would have been obvious, therefore, to use a

**SUBJECT TO PROTECTIVE ORDER
CONTAINS HIGHLY CONFIDENTIAL – ATTORNEYS’ EYES ONLY INFORMATION**

glass member as the protective layer, as taught by Perski '455, in order to provide a smooth surface for a finger touch and to protect the electrodes beneath.

227. It is therefore my opinion that Rekimoto discloses this limitation or at least renders it obvious.

(ii) Invalidity under Apple’s Proposed Construction

228. Apple contends that “glass member” should be construed to mean any glass or plastic material.

229. As described above, the protective layer (whether it is plastic or glass) is a third glass member disposed over the second conductive layer. It is therefore my opinion that Rekimoto discloses this limitation under Apple’s claim construction.

(w) Claim [10L] – “one or more sensor integrated circuits operatively coupled to the lines”

230. Rekimoto disclosed that one or more sensor integrated circuits are operatively coupled to the lines. For example, a transmitter is connected to the transmission electrodes and a receiver is connected to the reception electrodes. As explained in Rekimoto: “a plurality of linear transmission electrodes 11-1, 11-2, ..., 11-m; a transmitter 12 that supplies an AC current for transmission at a predetermined frequency...to the transmission electrodes 11-1...; a plurality of linear reception electrodes 15-1, 15-2, ..., 15-n, which receive the AC current from the transmission electrodes 11-1..., by way of an electrostatic effect; and a receiver 16 that receives the AC current flowing in the electrodes 15-1, The receiver 16 comprises: an AM modulator comprising a band pass filter (BPF) 16A, which allows only AC current at a predetermined frequency range to pass, an amplifier 16B and a detector 16C; and an A/D converter 16D, that converts the detector output to a digital format signal.” (Id. at ¶ [0030]).

231. It is therefore my opinion that Rekimoto discloses this limitation.

SUBJECT TO PROTECTIVE ORDER
CONTAINS HIGHLY CONFIDENTIAL – ATTORNEYS’ EYES ONLY INFORMATION

- (x) **Claim [11] – “The display arrangement as recited in claim 10 further including dummy features disposed in the space between the parallel lines, the dummy features optically improving the visual appearance of the touch screen by more closely matching the optical index of the lines”**

232. To the extent Rekimoto does not expressly or inherently disclose the claimed dummy features, the use of such features would have been obvious to one of ordinary skill in the art as a predictable variant and a matter of simple implementation design. Rekimoto clearly contemplates a transparent input device positioned in front of an organic display, so it would have been obvious to one of ordinary skill in the art to incorporate “dummy features” that optically improve the visual appearance of the touchscreen by more closely matching the optical index of the lines, as taught by Perski ‘455 (*see, e.g.*, Perski ‘455 at 5), U.S. Patent No. 7,292,229 to Morag (“Morag”) (*see, e.g.*, Morag at 12:64-13:32) or U.S. Patent No. 7,129,935 to Mackey (“Mackey”) (*see, e.g.*, Mackey at 8:17-39), in order to reduce the visual differences between the conducting and non-conducting areas and create a transparent touch screen with little or no visual distortions.

233. It is therefore my opinion that Rekimoto renders this limitation obvious, either by itself or in combination with Perski ‘455, Morag, or Mackey.

3. The ‘607 Patent is Invalid in View of Rekimoto

234. I have considered and compared asserted claims of the ‘607 patent to the claims and specification of Rekimoto, as described above. It is my opinion that Rekimoto anticipates claims 1-3, 6-8, and 10 of the ‘607 patent. It is also my opinion that Rekimoto renders claim 11 of the ‘607 patent obvious. My opinions are supported by Exhibit 607-06, which is a claim chart that shows how Rekimoto discloses the limitations of the asserted claims in more detail.

**SUBJECT TO PROTECTIVE ORDER
CONTAINS HIGHLY CONFIDENTIAL – ATTORNEYS’ EYES ONLY INFORMATION**

C. Smartskin Anticipates and/or Renders Obvious the Asserted Claims of the ‘607 Patent

235. “Smartskin: An Infrastructure for Freehand Manipulation on Interactive Surfaces,” Conference on Human Interaction 2002, by Jun Rekimoto, (“Smartskin”) was published between April 20-25, 2002. Smartskin appears to refer to the same input device described in Rekimoto and is by the same author.

236. Smartskin qualifies as prior art to the ’607 patent under 35 U.S.C. § 102(b).

237. According to the Abstract, Smartskin is “a new sensor architecture for making interactive surfaces that are sensitive to human hand and finger gestures.” (Smartskin at 1). Similar to the other prior art references I analyzed above, “[t]his sensor recognizes multiple hand positions and shapes and calculates the distance between the hand and the surface by using capacitive sensing and a mesh-shaped antenna.” (*Id.*). The mesh or grid-like arrangement includes both transmitter and receiver electrodes and describes a mutual capacitance sensing system. (*Id.* at 2).

238. As described above, ALJ Essex decided that Smartskin rendered all the asserted claims of the ‘607 patent obvious, by itself or in combination with Rekimoto. (*See* § (VI)(A) above).

239. I also understand that during the ITC investigation initiated against Motorola, Apple only contested the transparent, layer, and “glass member” limitations (750 ID at 147).

2. Analysis of the Claim Elements

- (a) Claim [1A] - “A touch panel comprising a transparent capacitive sensing medium configured to detect multiple touches or near touches that occur at a same time and at distinct locations in a plane of the touch panel and to produce distinct signals representative of a location of the touches on the plane of the touch panel for each of the multiple touches”**

SUBJECT TO PROTECTIVE ORDER
CONTAINS HIGHLY CONFIDENTIAL – ATTORNEYS’ EYES ONLY INFORMATION

240. Smartskin discloses a touch panel comprising a transparent capacitive sensing medium configured to detect multiple touches or near touches that occur at a same time and at distinct locations in a plane of the touch panel and to produce distinct signals representative of a location of the touches on the plane of the touch panel for each of the multiple touches.

241. For example, Smartskin states: “The sensor consists of grid-shaped transmitter and receiver electrodes (copper wires). The vertical wires are transmitter electrodes, and the horizontal wires are receiver electrodes. When one of the transmitter lines is excited by a wave signal (of typically several hundred kilohertz), the receiver receives this wave signal because each crossing point (transmitter/receiver pairs) acts as a (very weak) capacitor. The magnitude of the received signal is proportional to the frequency and voltage of the transmitted signal, as well as to the capacitance between the two electrodes. When a conductive and grounded object approaches a crossing point, it capacitively couples to the electrodes, and drains the wave signal. As a result, the received signal amplitude becomes weak. By measuring this effect, it is possible to detect the proximity of a conductive object, such as a human hand.” (Id. at 2). This description is amplified by Figure 2, reproduced below.

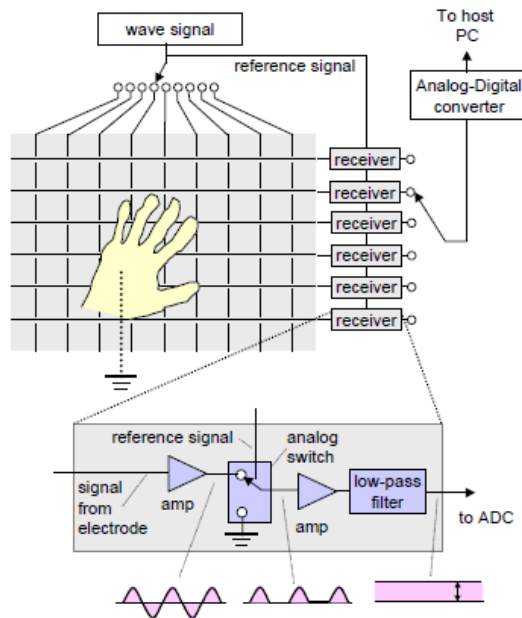

Figure 2: The SmartSkin sensor configuration: A mesh-shaped sensor grid is used to determine the hand’s position and shape.

242. Smartskin further states: “A notable advantage of SmartSkin over traditional mouse-based systems is its natural support for multiple-hand, multiple-user operations. Two or more users can simultaneously interact with the surface at the same time.... He or she can also ‘concatenate’ two objects by using both hands, as shown in Figure 7, or can take objects apart in the same manner.” (Id. at 4). Figure 7 is reproduced below and clearly shows the detection of multiple touches or near touches that occur at a same time and at distinct locations in a plane of the touch panel.

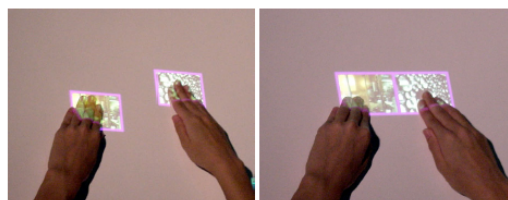

Figure 7: Two-handed operation is used to concatenate two objects.

**SUBJECT TO PROTECTIVE ORDER
CONTAINS HIGHLY CONFIDENTIAL – ATTORNEYS’ EYES ONLY INFORMATION**

243. Smartskin further states: “The system time-dividing transmitting signal is sent to each of the vertical electrodes and the system independently measures values from each of the receiver electrodes. These values are integrated to form two-dimensional sensor values, which we called ‘proximity pixels.’ Once these values are obtained, algorithms similar to those used in image processing, such as peak detection, connected region analysis, and template matching, can be applied to recognize gestures. As a result, the system can recognize multiple objects (e.g., hands). If the granularity of the mesh is dense, the system can recognize the shape of objects.” (Id. at 2). These proximity pixels are distinct signals representative of a location of the touches on the plane of the touch panel for each of the multiple touches. A transparent SmartSkin sensor is also disclosed using ITO conductors that could be used with a rear or front projection LCD display. (Id. at 7).

244. [REDACTED]

245. It is therefore my opinion that Smartskin discloses this limitation.

(b) Claim [1B] - “wherein the transparent capacitive sensing medium comprises: a first layer having a plurality of transparent first conductive lines that are electrically isolated from one another”

246. As described above and shown in Figure 2 of Smartskin, the sensor includes two layers of electrodes. The vertical wires are a layer of transmitter electrodes, and the horizontal wires are a layer of receiver electrodes.

247. It is therefore my opinion that Smartskin discloses this limitation.

(c) Claim [1C] – “and a second layer spatially separated from the first layer and having a plurality of transparent second

**SUBJECT TO PROTECTIVE ORDER
CONTAINS HIGHLY CONFIDENTIAL – ATTORNEYS’ EYES ONLY INFORMATION**

conductive lines that are electrically isolated from one another”

248. As described above and shown in Figure 2 of Smartskin, the sensor includes two layers of electrodes. The vertical wires are a layer of transmitter electrodes, and the horizontal wires are a layer of receiver electrodes. At each “crossing point” (i.e., transmitter/receiver electrode junction), “a (very weak) capacitor” is formed. (Id. at 2). As such, the transmitter electrode layer is spatially separated from the receiver electrode layer but close enough for capacitive coupling.

249. It is therefore my opinion that Smartskin discloses this limitation.

(d) Claim [1D] – “the second conductive lines being positioned transverse to the first conductive lines”

250. The mesh-like or grid arrangement of electrodes shown in Figure 2 of Smartskin includes vertical and horizontal electrodes. These electrodes are orthogonal or positioned transverse to each other because one layer of electrodes are horizontal while the other layer is vertical. *See* analysis of claim [1A] above.

251. It is therefore my opinion that Smartskin discloses this limitation.

(e) Claim [1E] – “the intersection of transverse lines being positioned at different locations in the plane of the touch panel, each of the second conductive lines being operatively coupled to capacitive monitoring circuitry”

252. As shown in Figure 2, the “crossing points” create weak capacitors which are spread evenly throughout the plane of the touch panel. The receiver electrodes are connected to capacitive monitoring circuitry which sense the change in capacitance at each junction. (Id. at 2).

253. It is therefore my opinion that Smartskin discloses this limitation.

SUBJECT TO PROTECTIVE ORDER
CONTAINS HIGHLY CONFIDENTIAL – ATTORNEYS’ EYES ONLY INFORMATION

(f) Claim [1F] - “wherein the capacitive monitoring circuitry is configured to detect changes in the charge coupling between the first conductive lines and the second conductive lines”

254. As described above, “[t]he vertical wires are transmitter electrodes, and the horizontal wires are receiver electrodes. When one of the transmitter lines is excited by a wave signal (of typically several hundred kilohertz), the receiver receives this wave signal because each crossing point (transmitter/receiver pairs) acts as a (very weak) capacitor. The magnitude of the received signal is proportional to the frequency and voltage of the transmitted signal, as well as to the capacitance between the two electrodes. When a conductive and grounded object approaches a crossing point, it capacitively couples to the electrodes, and drains the wave signal. As a result, the received signal amplitude becomes weak. By measuring this effect, it is possible to detect the proximity of a conductive object, such as a human hand.” (Id. at 2).

255. It is therefore my opinion that Smartskin discloses this limitation.

(g) Claim [2] - “The touch panel as recited in claim 1 wherein the conductive lines on each of the layers are substantially parallel to one another”

256. Smartskin discloses this limitation for the same reasons described above in connection with claim [1A]. As shown in Figure 2, the vertical electrodes are all substantially parallel to one another, and the horizontal electrodes are all substantially parallel to one another. (Id. at 2).

257. It is therefore my opinion that Smartskin discloses this limitation.

(h) Claim [3] - “The touch panel as recited in claim 2 wherein the conductive lines on different layers are substantially perpendicular to each other”

258. Smartskin discloses this limitation for the same reasons described above in connection with claim [1A]. As shown in Figure 2, the vertical electrodes are substantially perpendicular to the horizontal electrodes. (Id. at 2).

SUBJECT TO PROTECTIVE ORDER
CONTAINS HIGHLY CONFIDENTIAL – ATTORNEYS’ EYES ONLY INFORMATION

259. It is therefore my opinion that Smartskin discloses this limitation.

(i) Claim [6] - “The touch panel recited in claim 1 wherein the conductive lines are formed from indium tin oxide (ITO)”

260. Smartskin discloses that the conductive lines are formed from indium tin oxide (ITO).

261. For example, Smartskin states: “A transparent SmartSkin sensor can be obtained by using indium tin oxide (ITO) so that the lines on each layer are transparent. This sensor can be mounted in front of a flat panel display or on a rear-projection screen.” (Id. at 7).

262. It is therefore my opinion that Smartskin discloses this limitation.

(j) Claim [7] - “The touch panel as recited in claim 1, wherein the capacitive sensing medium is a mutual capacitance sensing medium”

263. Smartskin discloses that the capacitive sensing medium is a mutual capacitance sensing medium. Smartskin states: “The sensor consists of grid-shaped transmitter and receiver electrodes (copper wires). The vertical wires are transmitter electrodes, and the horizontal wires are receiver electrodes. When one of the transmitter lines is excited by a wave signal (of typically several hundred kilohertz), the receiver receives this wave signal because each crossing point (transmitter/receiver pairs) acts as a (very weak) capacitor. (Id. at 2). This is the description of a mutual capacitance sensing system. *See also* § (X)(B)(2)(j).

264. While not using the words “mutual capacitance sensing medium,” this description of the operation of the touch sensor of Smartskin is precisely the description of a mutual capacitance sensing medium as described in the ‘607 patent. *See* the discussion above in § (X)(A)(1)(j) in connection with claim [7] of Perski ‘455.

265. It is therefore my opinion that Rekimoto discloses this limitation.

**SUBJECT TO PROTECTIVE ORDER
CONTAINS HIGHLY CONFIDENTIAL – ATTORNEYS’ EYES ONLY INFORMATION**

266. Even if Smartskin did not disclose a mutual capacitance sensing medium, such a sensing medium would have been obvious to one of ordinary skill in the art at the time the invention described in the ‘607 patent was made. *See* § (X)(A)(1)(j) above.

(k) Claim [8] -- “The touch panel as recited in claim 7, further comprising a virtual ground charge amplifier coupled to the touch panel for detecting the touches on the touch panel”

267. Smartskin discloses a virtual ground charge amplifier coupled to the touch panel for detecting the touches on the touch panel.

268. For example Smartskin states: “To accurately measure signals only from the transmitter electrode, a technique called ‘lock-in amplifier’ is used. This technique uses an analogue switch as a phase-sensitive detector. The transmitter signal is used as a reference signal for switching this analog switch, to enable the system to select signals that have the synchronized frequency and the phase of the transmitted signal.” (Id. at 2).

269. It is therefore my opinion that Smartskin discloses this limitation. *See also* § X(B)(2)(k).

(l) Claim [10A] – “A display arrangement having a screen for displaying a graphical user interface”

270. Smartskin states: “A transparent SmartSkin sensor can be obtained by using indium tin oxide (ITO) so that the lines on each layer are transparent. This sensor can be mounted in front of a flat panel display or on a rear-projection screen.” (Id. at 7).

271. It is therefore my opinion that Smartskin discloses this limitation.

(m) Claim [10B] -- “a transparent touch panel allowing the screen to be viewed therethrough and capable of recognizing multiple touch events that occur at different locations on the touch panel at a same time and to output this information to a host device to form a pixilated image”

**SUBJECT TO PROTECTIVE ORDER
CONTAINS HIGHLY CONFIDENTIAL – ATTORNEYS’ EYES ONLY INFORMATION**

272. Smartskin states: “A transparent SmartSkin sensor can be obtained by using indium tin oxide (ITO) so that the lines on each layer are transparent. This sensor can be mounted in front of a flat panel display or on a rear-projection screen.” (Id. at 7). Smartskin further states: “The system time-dividing transmitting signal is sent to each of the vertical electrodes and the system independently measures values from each of the receiver electrodes. These values are integrated to form two-dimensional sensor values, which we called “proximity pixels.” Once these values are obtained, algorithms similar to those used in image processing, such as peak detection, connected region analysis, and template matching, can be applied to recognize gestures. As a result, the system can recognize multiple objects (e.g., hands). If the granularity of the mesh is dense, the system can recognize the shape of objects.” (Id. at 2). *See* also my analysis in connection with claim [1A].

273. It is therefore my opinion that Smartskin discloses this limitation.

- (n) **Claim [10C] – “wherein the touch panel includes a multipoint sensing arrangement configured to simultaneously detect and monitor the touch events and a change in capacitive coupling associated with those touch events at distinct points across the touch panel”**

274. Smartskin discloses a multipoint sensing arrangement configured to simultaneously detect and monitor the touch events and a change in capacitive coupling associated with those touch events at distinct points across the touch panel.

275. Smartskin discloses this limitation for at least the same reasons described above in connection with claim [1A].

276. It is therefore my opinion that Smartskin discloses this limitation.

- (o) **Claim 10[D] – “wherein the touch panel comprises: a first glass member disposed over the screen of the display;**

Smartskin discloses a first glass member disposed over the screen of a display under

**SUBJECT TO PROTECTIVE ORDER
CONTAINS HIGHLY CONFIDENTIAL – ATTORNEYS’ EYES ONLY INFORMATION**

Apple’s proposed claim construction and renders this limitation obvious under Samsung’s proposed construction.

(i) Invalidity under Samsung’s Proposed Construction

Samsung contends that “glass member” should be given its plain and ordinary meaning to mean “glass” as opposed to plastic materials.

277. Smartskin discloses the use of a transparent touch sensor over an LCD display. (Id. at 7). As shown in Figure 9, a grid mesh of conductors is arranged beneath a sheet of plastic insulating film. It is also inherent that each of the layers of conductors is disposed over a transparent dielectric, such as a glass member.

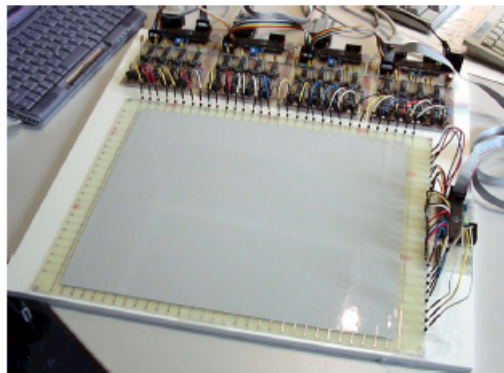

Figure 9: A gesture-recognition pad made up of a 32×24 grid mesh. A sheet of plastic insulating film covers Sensor electrodes.

278. To the extent a first glass member disposed over the screen of the display is not expressly or inherently shown in Smartskin, the use of a glass member would have been a predictable variant. Glass, as a transparent dielectric, is widely used in touchscreen displays. It would have been obvious, therefore, to use a glass member, as taught by Perski ’455, in order to sufficiently shield the mesh sensor grid from the display and provide a support for the first conductive layer.

279. It is therefore my opinion that Smartskin discloses this limitation under Samsung’s claim construction.

**SUBJECT TO PROTECTIVE ORDER
CONTAINS HIGHLY CONFIDENTIAL – ATTORNEYS’ EYES ONLY INFORMATION**

(ii) Invalidity under Apple’s Proposed Construction

280. Apple contends that “glass member” should be construed to mean any glass or plastic material.

281. As shown above, Smartskin describes a “sheet of plastic insulating film” covering the mesh grid of electrodes. This insulating film is a plastic material and is disposed over the screen of the display. (*Id.*).

282. As such, it is my opinion that Smartskin discloses this limitation under Apple’s proposed construction.

(p) Claim [10E] – “a first transparent conductive layer disposed over the first glass member”

283. Smartskin discloses this limitation for at least the same reasons as already described in connection with claim [1A].

(q) Claim [10F] – “the first transparent conductive layer comprising a plurality of spaced apart parallel lines having the same pitch and linewidths”

284. Smartskin discloses this limitation for at least the same reasons as already described in connection with claim [1A].

(r) Claim [10G] – “a second glass member disposed over the first transparent conductive layer”

285. Smartskin discloses a second glass member disposed over the first transparent conductive layer under Apple’s proposed claim construction and renders this limitation obvious under Samsung’s proposed construction.

(i) Invalidity under Samsung’s Proposed Construction

286. Samsung contends that “glass member” should be given its plain and ordinary meaning to mean “glass” as opposed to plastic materials.

**SUBJECT TO PROTECTIVE ORDER
CONTAINS HIGHLY CONFIDENTIAL – ATTORNEYS’ EYES ONLY INFORMATION**

287. Smartskin discloses the use of a transparent touch sensor over an LCD display. (Id. at 7). As shown in Figure 9, a grid mesh of conductors is arranged beneath a sheet of plastic insulating film. It is inherent that each of the layers of conductors is disposed over a transparent dielectric.

288. To the extent a second glass member is not expressly or inherently shown in Smartskin, the use of a glass member would have been a predictable variant. Glass, as a transparent dielectric, is widely used in touchscreen displays. It would have been obvious, therefore, to use a glass member, as taught by Perski ’455, in order to sufficiently provide a support for the second conductive layer.

289. It is therefore my opinion that Smartskin renders this limitation obvious under Samsung’s claim construction.

(ii) Invalidity under Apple’s Proposed Construction

290. Apple contends that “glass member” should be construed to mean any glass or plastic material.

291. As shown above, Smartskin describes a “sheet of plastic insulating film” covering the mesh grid of electrodes. This insulating film is a plastic material and is disposed the first transparent conductive layer. It is inherent that each of the layers of conductors is disposed over a transparent dielectric.

292. To the extent a second glass member disposed over the screen of the display is not expressly or inherently shown in Smartskin, the use of a glass member would have been a predictable variant. Glass, as a transparent dielectric, is widely used in touchscreen displays. It would have been obvious, therefore, to use a glass member, as taught by Perski ’455, in order to sufficiently provide a support for the second conductive layer.

**SUBJECT TO PROTECTIVE ORDER
CONTAINS HIGHLY CONFIDENTIAL – ATTORNEYS’ EYES ONLY INFORMATION**

293. As such, it is my opinion that Smartskin discloses this limitation under Apple’s proposed construction.

- (s) **Claim [10H] – “a second transparent conductive layer disposed over the second glass member**

294. Smartskin discloses this limitation for at least the same reasons as already described in connection with claim [1A].

- (t) **Claim [10I] – “the second transparent conductive member comprising a plurality of spaced apart parallel lines having the same pitch and linewidths”**

295. Smartskin discloses this limitation for at least the same reasons described above in connection with claim [10F].

- (u) **Claim [10J] – “the parallel lines of the second transparent conductive layer being substantially perpendicular to the parallel lines of the first transparent conductive layer”**

296. Smartskin discloses this limitation for at least the same reasons described above in connection with claim [1A].

- (v) **Claim [10K] -- “a third glass member disposed over the second conductive layer”**

297. Smartskin discloses a third glass member disposed over the second conductive layer under Apple’s proposed claim construction and renders this limitation obvious under Samsung’s proposed construction.

- (i) **Invalidity under Samsung’s Proposed Construction**

298. Samsung contends that “glass member” should be given its plain and ordinary meaning to mean “glass” as opposed to plastic materials.

299. To the extent a third glass member disposed over the second conductive layer is not expressly or inherently shown in Smartskin, the use of a glass member would have been a predictable variant. Glass, as a transparent dielectric, is widely used in touchscreen displays. It

**SUBJECT TO PROTECTIVE ORDER
CONTAINS HIGHLY CONFIDENTIAL – ATTORNEYS’ EYES ONLY INFORMATION**

would have been obvious, therefore, to use a glass member, as taught by Perski '455, in order to shield the conductors beneath and provide a smooth transparent surface for a finger touch.

300. It is therefore my opinion that Smartskin renders this limitation obvious under Samsung’s claim construction.

(ii) Invalidity under Apple’s Proposed Construction

301. Apple contends that “glass member” should be construed to mean any glass or plastic material.

302. As shown in Figure 9, a grid mesh of conductors is arranged beneath a sheet of plastic insulating film. The plastic insulating film is member disposed over the second conductive layer.

303. To the extent a third glass member disposed over the second conductive layer is not expressly or inherently shown in Smartskin, the use of a glass member would have been a predictable variant. Glass, as a transparent dielectric, is widely used in touchscreen displays. It would have been obvious, therefore, to use a glass member, as taught by Perski '455, in order to shield the conductors beneath and provide a smooth transparent surface for a finger touch.

304. As such, it is my opinion that Smartskin discloses this limitation under Apple’s proposed construction.

(w) Claim [10L] – “one or more sensor integrated circuits operatively coupled to the lines”

305. Smartskin discloses one or more sensor integrated circuits operatively coupled to the lines. For example, as shown in Figure 2, the receiver lines are coupled to receiver circuitry, including an operational amplifier, and low-pass filter. The output of this circuitry is then sent to the ADC.

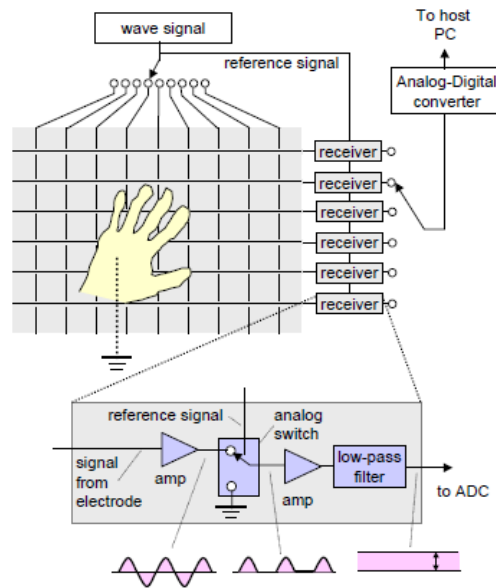

Figure 2: The SmartSkin sensor configuration: A mesh-shaped sensor grid is used to determine the hand's position and shape.

306. As such, it is my opinion that Smartskin discloses this limitation

- (x) **Claim [11] – “The display arrangement as recited in claim 10 further including dummy features disposed in the space between the parallel lines, the dummy features optically improving the visual appearance of the touch screen by more closely matching the optical index of the lines”**

307. To the extent Smartskin does not expressly or inherently disclose the claimed dummy features, the use of such features would have been obvious to one of ordinary skill in the art as a predictable variant and a matter of simple implementation design. Smartskin clearly contemplates a transparent input device positioned in front of an organic display, so it would have been obvious to one of ordinary skill in the art to incorporate “dummy features” that optically improve the visual appearance of the touchscreen by more closely matching the optical index of the lines, as taught by Perski ‘455 (*see, e.g.*, Perski ‘455 at 5), Morag (*see, e.g.*, Morag at 12:64-13:32), or Mackey (*see, e.g.*, Mackey at 8:17-39), in order to reduce the visual

**SUBJECT TO PROTECTIVE ORDER
CONTAINS HIGHLY CONFIDENTIAL – ATTORNEYS’ EYES ONLY INFORMATION**

differences between the conducting and non-conducting areas and create a transparent touch screen with little or no visual distortions.

308. It is therefore my opinion that Smartskin renders this limitation obvious, either by itself or in combination with Perski ‘455, Morag, or Mackey.

3. The ‘607 Patent is Invalid in View of Smartskin

309. As I have considered and compared asserted claims of the ‘607 patent to the claims and specification of Smartskin, as described above. It is my opinion that Smartskin anticipates claims 1-3, 6-8, and 10 of the ‘607 patent. It is also my opinion that Smartskin renders claim 11 of the ‘607 patent obvious. My opinions are supported by Exhibit 607-07, which is a claim chart that shows how Smartskin discloses the limitations of the asserted claims in more detail.

D. Mulligan Anticipates and/or Renders Obvious the Asserted Claims of the ‘607 Patent

310. U.S. Patent 6,970,160, entitled “Lattice Touch-Sensing System,” to Mulligan et al., was filed on December 19, 2002 and issued November 29, 2005. As such, Mulligan qualifies as prior art to the ‘607 patent under 35 U.S.C. § 102(e).

311. Mulligan describes a touch-sensitive surface that includes sensor bars laid out in a lattice. The surface includes “two capacitive sensing layers, separated by an insulating material, where each layer consists of substantially parallel conducting elements, and the conducting elements of the two sensing layers are substantially orthogonal to each other.” (Mulligan, Abstract).

2. Analysis of the Claim Elements

- (a) Claim [1A] - “A touch panel comprising a transparent capacitive sensing medium configured to detect multiple touches or near touches that occur at a same time and at**

**SUBJECT TO PROTECTIVE ORDER
CONTAINS HIGHLY CONFIDENTIAL – ATTORNEYS’ EYES ONLY INFORMATION**

distinct locations in a plane of the touch panel and to produce distinct signals representative of a location of the touches on the plane of the touch panel for each of the multiple touches”

312. Mulligan discloses a touch panel comprising a transparent capacitive sensing medium configured to detect multiple touches or near touches that occur at a same time and at distinct locations in a plane of the touch panel and to produce distinct signals representative of a location of the touches on the plane of the touch panel for each of the multiple touches.

313. Mulligan discloses a touch panel comprising a transparent capacitive sensing medium. *See, e.g.*, Mulligan at Figures 1 and 2. "The touch pane 220 is the uppermost layer of the touch-sensitive screen 210. The touch pane 220 may be made of an optically clear substance." *Id.* at 4:4-7. "The top layer of the lattice touch-sensing element 230 is the first sensor layer 240. The first sensor layer 240 includes a plurality of capacitive touch-sensitive sensor bars 270 . . . preferably construed of indium tin oxide (ITO) for optical transparency" *Id.* at 4:17-22. "The dielectric layer 250 may be an adhesive manufactured from any non-conductive, transparent material." *Id.* at 4:62-64.

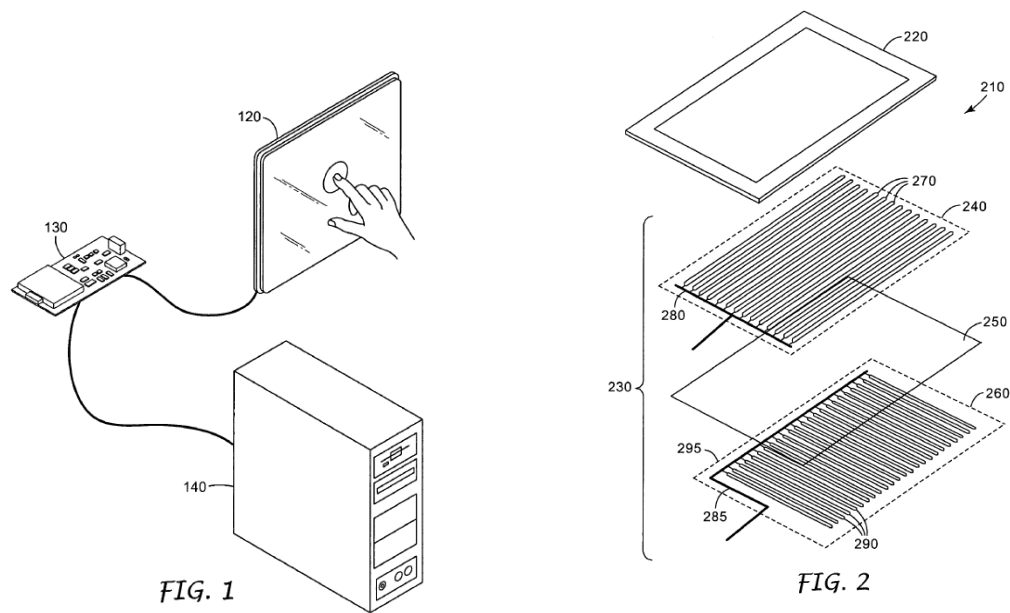

314. Mulligan’s lattice sensing system is also configured to detect multiple touches or near touches that occur at a same time and at distinct locations in a plane of the touch panel and to produce distinct signals representative of a location of the touches on the plane of the touch panel for each of the multiple touches. For example, Mulligan explains that “electrically connecting to both ends of the sensor bars could be used for the recognition of multiple touches.” *Id.* at 5:31-48; Figure 2; *see also id.* at 6:16-26 (“[T]he sensor bars of one or both layers may be electrically connected at both ends. Having the sensor bars connected at both ends in one or both layers provides certain benefits over the single-ended embodiments. Each sensor layer could provide more detailed information, including the touch location in both directions. This extra information could greatly improve multiple touch rejection, or, conversely, to enable multiple touch recognition. For instance, a two-layer sensor could be used in combination with a gaming application that allowed two players to simultaneously touch the touch sensor.”).

315. It is therefore my opinion that Mulligan discloses this limitation.

(b) Claim [1B] - “wherein the transparent capacitive sensing medium comprises: a first layer having a plurality of

**SUBJECT TO PROTECTIVE ORDER
CONTAINS HIGHLY CONFIDENTIAL – ATTORNEYS’ EYES ONLY INFORMATION**

transparent first conductive lines that are electrically isolated from one another”

316. Mulligan discloses a transparent capacitive sensing medium comprising a first layer having a plurality of transparent first conductive lines that are electrically isolated from one another. "The touch pane 220 is the uppermost layer of the touch-sensitive screen 210. The touch pane 220 may be made of an optically clear substance. The touch pane 220 may be manufactured from a chemically strengthened glass, transparent plastic, or any other acceptable dielectric material. One side of the touch pane 220 serves as the touch surface of the touch-sensitive screen 210, while the other side of the touch pane 220 is attached to the lattice touch-sensing element 230. The touch pane 220 provides the necessary dielectric material between the touching object and the sensing element, as well as protecting the touch-sensing element 230 from environmental hazards." *Id.* at 4:5-16; Figure 2.

317. Mulligan also explains that "[t]he top layer of the lattice touch-sensing element 230 is the first sensor layer 240. The first sensor layer 240 includes a plurality of capacitive touch-sensitive sensor bars 270 arranged substantially parallel to each other in a unidirectional manner. They are preferably constructed of indium tin oxide (ITO) for optical transparency" (*Id.* at 4:17-23; Figure 2).

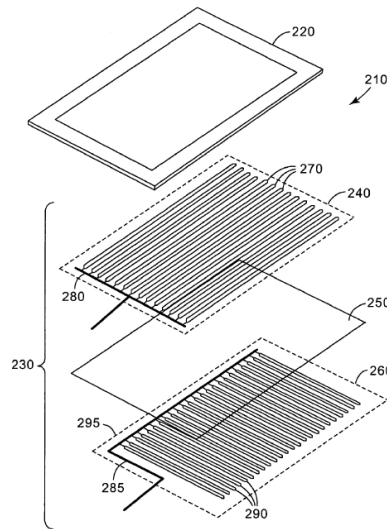

FIG. 2

318. It is therefore my opinion that Mulligan discloses this limitation.

- (c) **Claim [1C] – “and a second layer spatially separated from the first layer and having a plurality of transparent second conductive lines that are electrically isolated from one another”**

319. Mulligan discloses a second layer spatially separated from the first layer and having a plurality of transparent second conductive lines that are electrically isolated from one another.

320. For example, Mulligan states: "The second sensor layer 260 also includes a plurality of capacitive touch-sensitive sensor bars 290 arranged substantially parallel to each other in a unidirectional manner. The sensor layers 240 and 260 are parallel to each other with the sensor bar with the sensor bars 290 of the second sensor layer 260 being oriented substantially orthogonal to the sensor bars 270 of the first sensor layer 240." 4:28-34; Figure 2.

321. "The dielectric layer 250 is a non-conductive layer that separates the first sensor layer 240 and the second sensor layer 260. The dielectric layer 250 may be an adhesive manufactured from any non-conductive, transparent material. The dielectric layer 250 serves as

SUBJECT TO PROTECTIVE ORDER
CONTAINS HIGHLY CONFIDENTIAL – ATTORNEYS’ EYES ONLY INFORMATION

an electrical insulator, which prevents sensor bars 270 of the first sensor layer 240 and sensor bars 290 of the second sensor layer 260 from coming into direct contact." (Id. at 4:60-67; Figure 2).

322. It is therefore my opinion that Mulligan discloses this limitation.

(d) Claim [1D] – “the second conductive lines being positioned transverse to the first conductive lines”

323. Mulligan states: “As shown in FIG. 4, sensor bar 415 is oriented parallel to the X-axis 323, which is orthogonal to the Y-axis 325. The location of sensor bar 415 on the Y-axis 325 may be represented by Y1 425. Similarly, sensor bar 420 is oriented parallel to the Y-axis 325, which is orthogonal to X-axis 323. The location of sensor bar 420 on X-axis 323 may be represented by X1 430. By touching the touch sensitive screen at position 410, which corresponds to the intersection of sensor bar 415 and sensor bar 420, the object or the finger becomes capacitively coupled to both energized sensor bars, producing a response signal 435 on lead line 445 and a response signal 440 on lead line 450. Both signals are provided to the control circuit 130 (FIG. 1), where they are received and processed by the control circuit 130.” (Id. at 6:32-50).

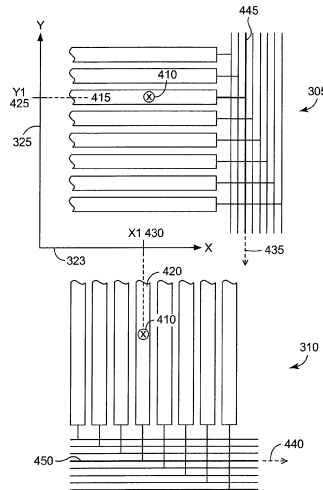

FIG. 4

324. It is therefore my opinion that Mulligan discloses this limitation.

- (e) **Claim [1E] – “the intersection of transverse lines being positioned at different locations in the plane of the touch panel, each of the second conductive lines being operatively coupled to capacitive monitoring circuitry”**

325. As shown in Figure 4 above, the sensor bars in the X-axis intersect the sensor bars in the Y-axis in different locations in the plane of the touch panel so as to cover the entire panel. (Id. at 6:32-50).

326. Mulligan also states that “[c]ontrol circuit 130 is a circuit that provides excitation current to the capacitive sensor bars in touch-sensitive screen 120. Control circuit 130 also detects and processes signals generated by the capacitive sensor bars.” (Id. at 3:49-59).

327. It is therefore my opinion that Mulligan discloses this limitation.

- (f) **Claim [1F] - “wherein the capacitive monitoring circuitry is configured to detect changes in the charge coupling between the first conductive lines and the second conductive lines”**

328. Mulligan discloses that the capacitive monitoring circuitry is configured to detect changes in the charge coupling between the first conductive lines and the second conductive lines.

**SUBJECT TO PROTECTIVE ORDER
CONTAINS HIGHLY CONFIDENTIAL – ATTORNEYS’ EYES ONLY INFORMATION**

329. For example, Mulligan states: “Briefly stated here, and described in greater detail in conjunction with FIGS. 3 and 4, the sensor bars 270/290 receive an excitation signal via the lead lines 280/285 from the control circuit 130. The excitation signal sets up an electric field on each sensor bar 270/290. A touch to the touch-sensitive screen 210 results in a capacitive coupling between the touching object and the sensor bars 270/290 of both layers in the area proximate to the touch.” (Id. at 5:1-17).

330. Mulligan discloses a number of different ways to measure touches or near touches. In one embodiment, "the sensing bars of each layer may be excited one at a time, while the sensing bars of the other layer are kept at a fixed potential or driven with some other signal, such as a guard signal." (Id. 6:5-13). A person of ordinary skill in the art would understand this embodiment to disclose measuring changes in charge coupling between the sensor bars of the first layer and the sensor bars of the second layer.

331. It is therefore my opinion that Mulligan discloses this limitation.

(g) Claim [2] - “The touch panel as recited in claim 1 wherein the conductive lines on each of the layers are substantially parallel to one another”

332. Mulligan discloses this limitation for at least the same reasons as described above in connection with claims [1C].

333. It is therefore my opinion that Mulligan discloses this limitation.

(h) Claim [3] - “The touch panel as recited in claim 2 wherein the conductive lines on different layers are substantially perpendicular to each other”

334. Mulligan discloses this limitation for at least the same reasons as described above in connection with claims [1C] and [1D].

335. It is therefore my opinion that Mulligan discloses this limitation.

**SUBJECT TO PROTECTIVE ORDER
CONTAINS HIGHLY CONFIDENTIAL – ATTORNEYS’ EYES ONLY INFORMATION**

(i) Claim [6] - “The touch panel recited in claim 1 wherein the conductive lines are formed from indium tin oxide (ITO)”

336. Mulligan states: “The plurality of capacitive touch-sensitive sensor bars...are preferably construed of indium tin oxide (ITO) for optical transparency....” (Id. at 4:19-22).

337. It is therefore my opinion that Mulligan discloses this limitation.

(j) Claim [7] - “The touch panel as recited in claim 1, wherein the capacitive sensing medium is a mutual capacitance sensing medium”

338. Mulligan states: “When in operation, the control circuit 130 sets up an electric potential on sensor bars 315 and sensor bars 320 via the corresponding lead lines 330 and 335. The excitation signal electrically energizes sensor bars 315 and sensor bars 320. The excitation of the sensing layers may be simultaneous or sequential. In another embodiment, the sensing bars of each layer may be excited one at a time, while the sensing bars of the other layer are kept at a fixed potential or driven with some other signal, such as a guard signal.” (Id. at 6:5-13).

339. Mulligan further explains “It should be appreciated that only one response signal from each layer is shown for simplicity of illustration. In actual operation, a touch may produce signals of various strengths on multiple sensor bars of a single sensor layer. The control circuit may determine the touch position by taking into account the signals from multiple bars in the immediate neighborhood of the touched bars. A linear or non-linear interpolation of the multiple signals from each layer may be used to accurately determine the touch position.” Id. at 6:51-60.

340. While not using the words “mutual capacitance sensing medium,” this description of the operation of the input device of Mulligan is precisely the description of a mutual capacitance sensing medium as described in the ‘607 patent. The electrodes of one layer are excited one at a time, while all the electrodes of the other layer are held at a fixed potential or driven to a guard signal so as to sense any capacitance change at the intersections of the

SUBJECT TO PROTECTIVE ORDER
CONTAINS HIGHLY CONFIDENTIAL – ATTORNEYS’ EYES ONLY INFORMATION

electrodes. This is the exact sequential scanning operation described in the '607 patent. *See* the discussion above in § (X)(A)(1)(j) in connection with claim [7] of Perski '455.

341. It is therefore my opinion that Rekimoto discloses this limitation.

342. Even if Mulligan did not disclose a mutual capacitance sensing medium, such a sensing medium would have been obvious to one of ordinary skill in the art at the time the invention described in the '607 patent was made. *See* § (X)(A)(1)(j) above.

(k) Claim [8] -- “The touch panel as recited in claim 7, further comprising a virtual ground charge amplifier coupled to the touch panel for detecting the touches on the touch panel”

343. Mulligan states: “Control circuit 130 is a circuit that provides excitation current to the capacitive sensor bars in touch-sensitive screen 120. Control circuit 130 also detects and processes signals generated by the capacitive sensor bars. While driving and sensing signals on one layer, the control circuit 130 could put the other layer in any appropriate state, such as float the other layer or drive the other layer with a known signal or guard signal. Control circuit 130 may be of any type of electronic circuit, such as an integrated circuit. Control circuit 130 may be installed by itself or integrated into a computer, such as computer 140.” (*Id.* at 3:49-59). The guard signal could be a ground signal, thereby inherently disclosing a virtual ground charge amplifier within control circuit 130.

344. It is therefore my opinion that Mulligan discloses this limitation.

345. Even if Mulligan did not expressly or inherently disclose a virtual ground charge amplifier, it would have been obvious to one of ordinary skill in the art to use a virtual ground charge amplifier as one of the several ways that detection of touches on the touch panel could have been performed. One such example of such a detection method is that of Blonder et al., U.S. Patent No. 5,113,041 issued May 12, 1992 (“Blonder”). As shown in Figure 3a of Blonder,

**SUBJECT TO PROTECTIVE ORDER
CONTAINS HIGHLY CONFIDENTIAL – ATTORNEYS’ EYES ONLY INFORMATION**

reproduced below, element 30 is a virtual ground charge amplifier coupled to the touch panel for detecting the touches on the touch panel. It would have been obvious to one of ordinary skill in the art to include the virtual ground charge amplifier of Blonder in the lattice touch sensing system of Mulligan as a predictable variant and a matter of simple design implementation in order, e.g., to reduce noise from stray capacitance.

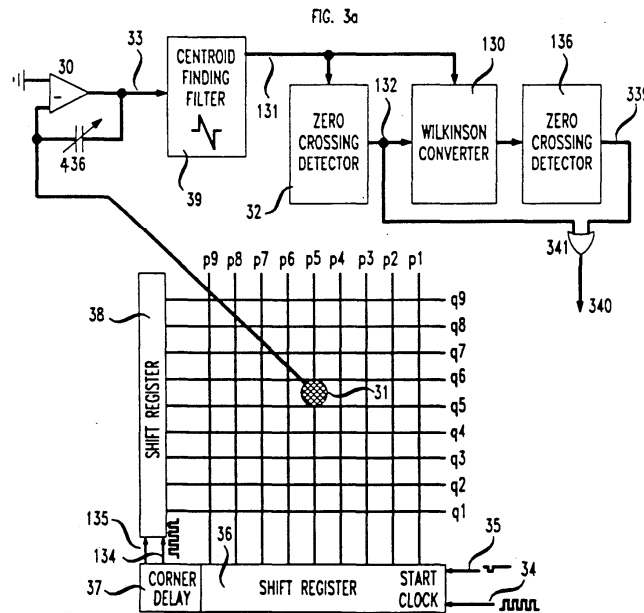

346. It is therefore my opinion that Mulligan discloses this limitation.

- (l) **Claim [10A] – “A display arrangement having a screen for displaying a graphical user interface”**

347. Mulligan discloses this limitation for at least the same reasons as described above in connection with claim [1A].

- (m) **Claim [10B] -- “a transparent touch panel allowing the screen to be viewed therethrough and capable of recognizing multiple touch events that occur at different locations on the touch panel at a same time and to output this information to a host device to form a pixilated image”**

348. Mulligan discloses this limitation for at least the same reasons as described above in connection with claims [1A].

**SUBJECT TO PROTECTIVE ORDER
CONTAINS HIGHLY CONFIDENTIAL – ATTORNEYS’ EYES ONLY INFORMATION**

- (n) **Claim [10C] – “wherein the touch panel includes a multipoint sensing arrangement configured to simultaneously detect and monitor the touch events and a change in capacitive coupling associated with those touch events at distinct points across the touch panel”**

349. Mulligan discloses this limitation for at least the same reasons as described above in connection with claims [1A].

- (o) **Claim 10[D] – “wherein the touch panel comprises: a first glass member disposed over the screen of the display;**

350. Mulligan discloses this limitation for at least the same reasons as described above in connection with claims [1C] and [1D] under both parties’ proposed constructions.

(i) **Invalidity under Samsung’s Proposed Construction**

351. Samsung contends that “glass member” should be given its plain and ordinary meaning to mean “glass” as opposed to plastic materials.

352. Mulligan states: “The touch pane 220 is the uppermost layer of the touch-sensitive screen 210. The touch pane 220 may be made of an optically clear substance. The touch pane 220 may be manufactured from a chemically strengthened glass, transparent plastic, or any other acceptable dielectric material. One side of the touch pane 220 serves as the touch surface of the touch-sensitive screen 210, while the other side of the touch pane 220 is attached to the lattice touch-sensing element 230. The touch pane 220 provides the necessary dielectric material between the touching object and the sensing element, as well as protecting the touch-sensing element 230 from environmental hazards.” Id. at 4:5-16.

353. Mulligan describes “dielectric layer 250” as “a non-conductive layer that separates the first sensor layer 240 and the second sensor layer 260. The dielectric layer 250 may be an adhesive manufactured from any non-conductive, transparent material. The dielectric layer 250 serves as an electrical insulator, which prevents sensor bars 270 of the first sensor layer

**SUBJECT TO PROTECTIVE ORDER
CONTAINS HIGHLY CONFIDENTIAL – ATTORNEYS’ EYES ONLY INFORMATION**

240 and sensor bars 290 of the second sensor layer 260 from coming into direct contact." (Id. at 4:60-67; Figure 2). A person of ordinary skill in the art would understand that "dielectric layer 250, [the] non-conductive layer that separates the first sensor layer 240 and the sensor layer 260" could be made from any of the "acceptable dielectric materials" specifically disclosed in Mulligan, which include "chemically strengthened glass" and "transparent plastic." (Id. at 4:8-9).

354. A person of ordinary skill in the art would understand that a first glass member, (which would be the glass member located over the display and under transparent conductive layer 260), is inherently disclosed by Mulligan. As described above and depicted in Figure 2 of Mulligan, dielectric layers 220 and 250 may be glass members. However, a person of ordinary skill would recognize that the bottom layer in Figure 2 is a sensor layer, and understand that in order for the sensor assembly pictured in Figure 2 to be employed as a touch screen, this sensor assembly could be laid on top of an LCD, which would represent the first glass member. Indeed, Mulligan specifically discloses that exemplary uses of capacitive touch screens are "hand-held personal digital assistants, automatic teller machines, casino game-machines, and the like." (Id. at 1:14-18). A person of ordinary skill in the art would understand that each of these devices uses an LCD display that could be a glass member.

355. It is therefore my opinion that Mulligan discloses this limitation under Samsung’s claim construction.

(ii) Invalidity under Apple’s Proposed Construction

356. Apple contends that “glass member” should be construed as any glass or plastic material. As described above, a person of ordinary skill in the art would understand that various sensing layers could be made from any of the "acceptable dielectric materials" specifically disclosed in Mulligan, which include "chemically strengthened glass" and "transparent plastic."

**SUBJECT TO PROTECTIVE ORDER
CONTAINS HIGHLY CONFIDENTIAL – ATTORNEYS’ EYES ONLY INFORMATION**

(Id. at 4:8-9). A person of ordinary skill in the art would understand that a first glass member, (which would be the glass member located over the display and under transparent conductive layer 260), is inherently disclosed by Mulligan. This glass member could be made from any of the "acceptable dielectric materials" specifically disclosed in Mulligan, which include "chemically strengthened glass" and "transparent plastic." (Id. at 4:8-9).

357. It is thus my opinion that Mulligan discloses this limitation under Apple’s proposed construction.

(p) Claim [10E] – “a first transparent conductive layer disposed over the first glass member”

358. Mulligan discloses this limitation for at least the same reasons as described above in connection with claims [1A].

(q) Claim [10F] – “the first transparent conductive layer comprising a plurality of spaced apart parallel lines having the same pitch and linewidths”

359. Mulligan discloses this limitation for at least the same reasons as described above in connection with claims [1A].

(r) Claim [10G] – “a second glass member disposed over the first transparent conductive layer”

360. Mulligan discloses this limitation for at least the same reasons as described above in connection with claims [1C] and [1D] under both parties’ proposed constructions.

(i) Invalidity under Samsung’s Proposed Construction

361. As described above, “dielectric layer 250” can be glass or plastic. *See* analysis above with respect to claim [10D]. It is therefore my opinion that Mulligan discloses this limitation under Samsung’s claim construction.

(ii) Invalidity under Apple’s Proposed Construction

**SUBJECT TO PROTECTIVE ORDER
CONTAINS HIGHLY CONFIDENTIAL – ATTORNEYS’ EYES ONLY INFORMATION**

362. As described above, “dielectric layer 250” can be glass or plastic. *See* analysis above with respect to claim [10D]. It is therefore my opinion that Mulligan discloses this limitation under Apple’s claim construction.

(s) Claim [10H] – “a second transparent conductive layer disposed over the second glass member

363. Mulligan discloses this limitation for at least the same reasons as described above in connection with claims [1A].

(t) Claim [10I] – “the second transparent conductive member comprising a plurality of spaced apart parallel lines having the same pitch and linewidths”

364. Mulligan discloses this limitation for at least the same reasons described above in connection with claim [10F].

(u) Claim [10J] – “the parallel lines of the second transparent conductive layer being substantially perpendicular to the parallel lines of the first transparent conductive layer”

365. Mulligan discloses this limitation for at least the same reasons as described above in connection with claims [1A].

(v) Claim [10K] -- “a third glass member disposed over the second conductive layer”

366. Mulligan discloses this limitation for at least the same reasons as described above in connection with claims [1C] and [1D] under both parties’ proposed constructions.

(i) Invalidity under Samsung’s Proposed Construction

367. Mulligan states: “The touch pane 220 is the uppermost layer of the touch-sensitive screen 210. The touch pane 220 may be made of an optically clear substance. The touch pane 220 may be manufactured from a chemically strengthened glass, transparent plastic, or any other acceptable dielectric material. One side of the touch pane 220 serves as the touch surface of the touch-sensitive screen 210, while the other side of the touch pane 220 is attached to the lattice

**SUBJECT TO PROTECTIVE ORDER
CONTAINS HIGHLY CONFIDENTIAL – ATTORNEYS’ EYES ONLY INFORMATION**

touch-sensing element 230. The touch pane 220 provides the necessary dielectric material between the touching object and the sensing element, as well as protecting the touch-sensing element 230 from environmental hazards.” (Id. at 4:5-16).

368. It is therefore my opinion that Mulligan discloses this limitation under Samsung’s claim construction.

(ii) Invalidity under Apple’s Proposed Construction

369. As described above, touch pane 220 can composed of “chemically strengthened glass, transparent plastic, or any other acceptable dielectric material.” (Id. at 4:5-16).

370. It is therefore my opinion that Mulligan discloses this limitation under Apple’s claim construction.

(w) Claim [10L] – “one or more sensor integrated circuits operatively coupled to the lines”

371. Mulligan discloses this limitation for at least the same reasons described above in connection with claim [1E].

(x) Claim [11] – “The display arrangement as recited in claim 10 further including dummy features disposed in the space between the parallel lines, the dummy features optically improving the visual appearance of the touch screen by more closely matching the optical index of the lines”

372. Mulligan states that the conductive lines “are preferably constructed of indium tin oxide (ITO) for optical transparency, but may be constructed of any conductive transparent material for transparent applications, such as other transparent conductive oxides as well as transparent conductive polymers. “ Id. at 4:21-27.

373. Mulligan clearly contemplates a transparent input device positioned in front of an organic display, so it would have been obvious to one of ordinary skill in the art to incorporate “dummy features” that optically improve the visual appearance of the touchscreen by more

SUBJECT TO PROTECTIVE ORDER
CONTAINS HIGHLY CONFIDENTIAL – ATTORNEYS’ EYES ONLY INFORMATION

closely matching the optical index of the lines, as taught by Perski ‘455 (*see, e.g.*, Perski ‘455 at 5), Morag (*see, e.g.*, Morag at 12:64-13:32), or Mackey (*see, e.g.*, Mackey at 8:17-39), in order to reduce the visual differences between the conducting and non-conducting areas and create a transparent touch screen with little or no visual distortions.

374. It is therefore my opinion that Mulligan renders this limitation obvious, either by itself or in combination with Perski ‘455, Morag, or Mackey.

3. The ‘607 Patent is Invalid in View of Mulligan

375. I have considered and compared asserted claims of the ‘607 patent to the claims and specification of Mulligan, as described above. It is my opinion that Mulligan anticipates claims 1-3, 6-8, and 10 of the ‘607 patent. It is also my opinion that Mulligan renders claim 11 of the ‘607 patent obvious. My opinions are supported by Exhibit 607-08, which is a claim chart that shows how Mulligan discloses the limitations of the asserted claims in more detail.

E. Hsu Anticipates and/or Renders Obvious the Asserted Claims of the ‘607 Patent

376. U.S. Patent No. 7,030,860, entitled “Flexible Transparent Touch Sensing System for Electronic Devices,” to Andrew Hsu et al. (“Hsu”) was filed on October 8, 1999, issued April 18, 2006, and is assigned to Synaptics, Inc. As such, Hsu qualifies as prior art to the ‘607 patent under 35 U.S.C. § 102(e).

377. Hsu describes a commercial product from Synaptics Incorporated called the ClearPad. (Day Dep. Tr. 89:1-13). This commercial product, which was on sale in the United States at least as early as 2002, is also an invalidating reference in its own right. (Day Dep. Tr. 32:21-25; 34:2-6). Hsu also expressly incorporates by reference U.S. Patent Nos. 5,880,411 (“Gillespie”) and 5,305,017 (“Gerpheide”). I understand that because the disclosure of these patents was expressly incorporated by reference in Hsu, Hsu, Gillespie, and Gerpheide may be

**SUBJECT TO PROTECTIVE ORDER
CONTAINS HIGHLY CONFIDENTIAL – ATTORNEYS’ EYES ONLY INFORMATION**

treated as a single invalidating reference for purposes of this analysis. To the extent these reference may not be treated as a single reference, it would have been obvious to combine Gillespie, Gerpheide, or both with Hsu because they were expressly incorporated by reference in Hsu. Hsu also gives an express motivation to combine the references for “suitable algorithms and means for implementing [the] sensor.” (Hsu at 6:31-34).

378. Hsu describes “[a] transparent, capacitive sensing system particularly well suited for input to electronic devices.” (Hsu at Abstract). The sensing system may be overlaid on an active display device and be used to emulate physical buttons or slider switches. (Hsu at Abstract).

2. Analysis of the Claim Elements

- (a) **Claim [1A] - “A touch panel comprising a transparent capacitive sensing medium configured to detect multiple touches or near touches that occur at a same time and at distinct locations in a plane of the touch panel and to produce distinct signals representative of a location of the touches on the plane of the touch panel for each of the multiple touches”**

379. Hsu discloses a touch panel (e.g., sensor 36 of FIG. 4) comprising a transparent capacitive sensing medium (e.g., two dimensional position sensing system 32 of FIG. 4) configured to detect multiple touches or near touches that occur at a same time and at distinct locations in a plane of the touch panel and to produce distinct signals representative of a location of the touches on the plane of the touch panel for each of the multiple touches.

**SUBJECT TO PROTECTIVE ORDER
CONTAINS HIGHLY CONFIDENTIAL – ATTORNEYS’ EYES ONLY INFORMATION**

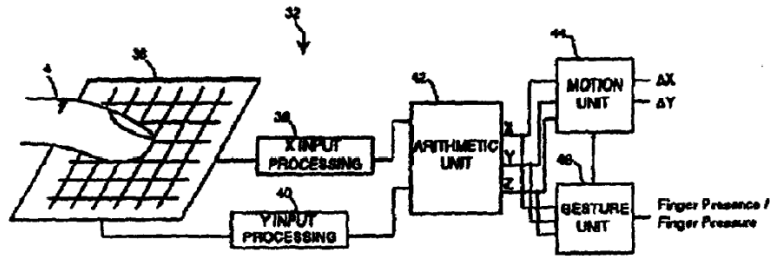

Figure 4

380. Hsu describes Figure 4, above, as “a schematic representation of a two-dimensional position sensing system 32. Such a system can determine finger presence as finger position along two direction axes. Finger 4 capacitively couples to sensor traces in sensor 36. X input processing block 38 and Y input processing block 40 measure capacitance values of sensor traces in the X and Y trace arrays and digitize the capacitance values. Arithmetic unit 42 computes position and pressure coordinates based on the digitized capacitance values. Next position and pressure coordinates are fed into motion unit 44 and gesture unit 46. Motion unit 44 computes relative movement of the finger compared to the previous position of the finger. Gesture unit 46 determines the finger presence over time and whether it constitutes a gesture such as a tap.” (*Id.* at 6:14-37).

381. Instead of describing the details of the underlying sensor operation in detail, Hsu incorporated by reference two other U.S. Patent documents: “Suitable algorithms and means for implementing this sensor include the technologies described in U.S. Pat. Nos. 5,880,411 and 5,305,017, incorporated in their entirety by reference thereto as described above. Those skilled in the art will recognize that such algorithms are only illustrative and in no way limiting of the capacitive sensing technology that is possible with this sensor.” (*Id.*).

382. Gillespie, one of the references incorporated by reference into Hsu, specifically mentions multi-touch support several times. For example, Gillespie explains: “Of the touchpad

SUBJECT TO PROTECTIVE ORDER
CONTAINS HIGHLY CONFIDENTIAL – ATTORNEYS’ EYES ONLY INFORMATION

devices currently available, only the Alps/Cirque GlidePoint includes gesture recognition. The GlidePoint supports basic tap, double-tap, and drag gestures to simulate actions on a primary mouse button. It does not support multiple-finger gestures, nor are there gestures for simulating secondary button clicks.” (Gillespie at 4:20-25). As such, an express object of the invention described in Gillespie “is to provide for the recognition of multiple-finger gestures and for simulating secondary button clicks.” (*Id.* at 5:22-24). (*See also* Day Dep. Tr. at 55:5-16; 58:6-14; 56:8-15; 110:19-113:3).

383. When asked about the sensor described in Hsu, Shawn Day, one of the named co-inventors of Hsu, said that it was “pretty clear” that Hsu had the ability to detect multiple touches at the same time and at distinct locations. (Day Dep. Tr. 110:19-111:16). Mr. Day then testified that the “multiple-finger gestures” described in Gillespie could include the pinch-to-zoom gesture, which I understand is a commonly multi-touch gesture used in cellphones today that detects multiple touches at distinct locations at the same time. (Day Dep. Tr. 111:24-112:6). Gillespie also makes another reference to its ability to detect multiple touches or near touches that occur at a same time and at distinct locations in a plane of the touch panel when it states: “[t]he sensor of the present invention can be conformed to any surface and can be made to detect multiple touching points, making possible a more powerful joystick.” (*Id.* at 52:1-3).

384. It is therefore my opinion that Hsu discloses this limitation.

(b) Claim [1B] - “wherein the transparent capacitive sensing medium comprises: a first layer having a plurality of transparent first conductive lines that are electrically isolated from one another”

385. Hsu discloses a transparent capacitive sensing medium (e.g., two dimensional position sensing system 32 of FIG. 4) comprising a first layer (e.g., electrically insulating

**SUBJECT TO PROTECTIVE ORDER
CONTAINS HIGHLY CONFIDENTIAL – ATTORNEYS’ EYES ONLY INFORMATION**

substrate 62 of FIG. 5A) having a plurality of transparent first conductive lines (e.g., traces 64 of FIG. 5A) that are electrically isolated from one another.

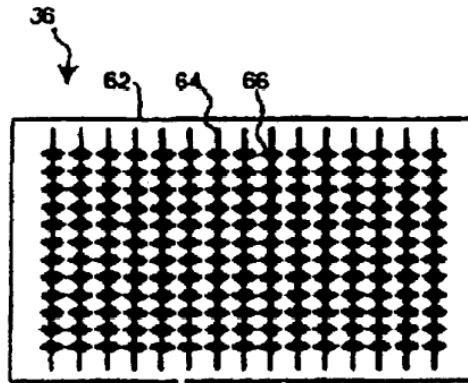

Figure 5A

386. Hsu explains: “FIG. 5A shows the preferred embodiment for the array of sensor traces used to compute position in the X-axis in sensor 36. Each trace 64 is a transparent conductor, equally spaced on a transparent, electrically insulating substrate 62. Each diamond 66 increases the trace area and also leaves a pattern of diamond-shaped regions containing no conductive material.” (Hsu at 6:38-50).

387. It is therefore my opinion that Hsu discloses this limitation.

(c) Claim [1C] – “and a second layer spatially separated from the first layer and having a plurality of transparent second conductive lines that are electrically isolated from one another”

388. Hsu discloses a second layer (e.g., electrically insulating substrate 62 of FIG. 5B) spatially separated from the first layer and having a plurality of transparent second conductive lines (e.g., traces 70 of FIG. 5B) that are electrically isolated from one another.

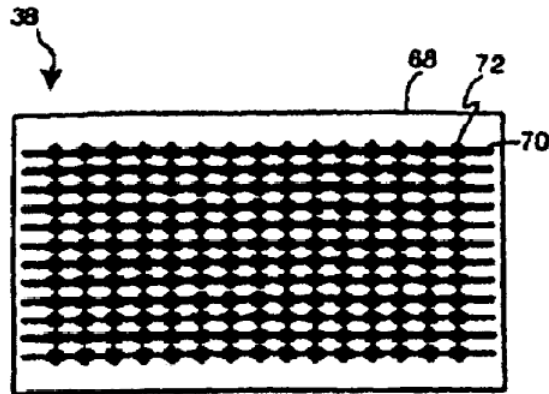

Figure 5B

389. As shown in Figure 5B, each trace 70 is used to compute position in the Y-axis for sensor 36. As explained in Hsu, “[e]ach trace 70 is also a transparent conductor, equally spaced on transparent, electrically insulating substrate 68.” (Id. at 6:38-50).

390. It is therefore my opinion that Hsu discloses this limitation.

(d) Claim [1D] – “the second conductive lines being positioned transverse to the first conductive lines”

391. Figure 5C shows the two arrays of sensor traces overlaid on the touchscreen. One layer of traces is arranged in the horizontal direction, while the other layer is arranged in the vertical direction. The two sets of traces are positioned transverse to each other. (See Day Tr. 90:2-12).

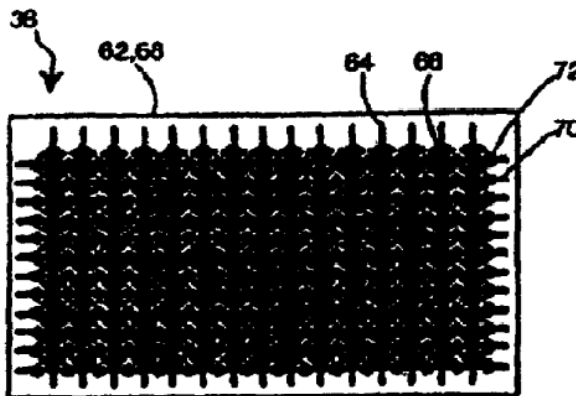

Figure 5C

SUBJECT TO PROTECTIVE ORDER
CONTAINS HIGHLY CONFIDENTIAL – ATTORNEYS’ EYES ONLY INFORMATION

392. It is therefore my opinion that Hsu discloses this limitation.

- (e) **Claim [1E] – “the intersection of transverse lines being positioned at different locations in the plane of the touch panel, each of the second conductive lines being operatively coupled to capacitive monitoring circuitry”**

393. Hsu states: “FIG. 4 is a schematic representation of a two-dimensional position sensing system 32. Such a system can determine finger presence as finger position along two direction axes. Finger 4 capacitively couples to sensor traces in sensor 36. X input processing block 38 and Y input processing block 40 measure capacitance values of sensor traces in the X and Y trace arrays and digitize the capacitance values.” (Id. at 6:14-37). As can be seen in Figures 5A-5C above, the intersection of the X and Y trace arrays occur at different locations in the plane of the touch panel, and the processing blocks, which are connected to the traces, are part of the capacitive monitoring circuitry.

394. It is therefore my opinion that Hsu discloses this limitation.

- (f) **Claim [1F] - “wherein the capacitive monitoring circuitry is configured to detect changes in the charge coupling between the first conductive lines and the second conductive lines”**

395. Both of the U.S. Patent documents incorporated by reference into Hsu show mutual capacitive sensing arrangements that are configured to detect changes in the charge coupling between the first conductive lines and the second conductive lines. For example, Gerpheide states: “In preferred embodiments, the electrical measurement accomplished is a capacitive measurement between the electrode strips.” (Gerpheide at 8:17-20). As would be understood to one of ordinary skill in the art, measuring the capacitive between two electrode strips is the definition of a mutual capacitive measurement. (*See, e.g.*, Day Dep. Tr. 25:8-13; Hotelling Dep. Tr. 78:24-79:2). Gerpheide even expressly describes how to compute *mutual capacitance* values: “To understand capacitive balance as it is used throughout, first define

**SUBJECT TO PROTECTIVE ORDER
CONTAINS HIGHLY CONFIDENTIAL – ATTORNEYS’ EYES ONLY INFORMATION**

M(A,B) to denote the well-known mutual capacitance between virtual electrodes A and B when all other electrodes in the pad are grounded. $M(C[i]<p>, R[j]<n>)$, for example, denotes the mutual capacitance between the positive half of VDE C[i] and the negative half of VDE R[j].” (Gerpheide at 9:62-68).

396. Gillespie similarly detects changes in charge coupling between conductive lines. Gillespie states: “The present invention uses adaptive analog techniques to overcome offset and scale differences between channels, and can thus sense either transcapacitance or self-capacitance of all tablet rows or columns in parallel. This parallel-sensing capability, made possible by providing one set of electronics per row or column, allows the sensing cycle to be extremely short, thus allowing fast response while still maintaining immunity to very high levels of electrical interference.” (Gillespie at 5:35-42). As is well-known in the art, “transcapacitance” is synonymous with mutual capacitance. Mr. Day, a co-inventor of Hsu, confirmed this understanding at his deposition. (Day Dep. Tr. 26:2-11). As such, both Gillespie and Gerpheide are mutual capacitive type sensing arrangements that measure the capacitance between two electrodes, just like in the ‘607 patent.

397. It is therefore my opinion that Hsu discloses this limitation.

(g) Claim [2] - “The touch panel as recited in claim 1 wherein the conductive lines on each of the layers are substantially parallel to one another”

398. As shown above in connection with claim 1, the conductive lines on each of the layers are substantially parallel to one another. *See* analysis for claims [1B] and [1C].

399. It is therefore my opinion that Hsu discloses this limitation.

(h) Claim [3] - “The touch panel as recited in claim 2 wherein the conductive lines on different layers are substantially perpendicular to each other”

SUBJECT TO PROTECTIVE ORDER
CONTAINS HIGHLY CONFIDENTIAL – ATTORNEYS’ EYES ONLY INFORMATION

400. As shown above in connection with claim 1, the conductive lines on different layers are substantially perpendicular. *See* analysis for claim [1D].

401. It is therefore my opinion that Hsu discloses this limitation.

(i) Claim [6] - “The touch panel recited in claim 1 wherein the conductive lines are formed from indium tin oxide (ITO)”

402. Hsu discloses that the conductive lines are formed from indium tin oxide (ITO). For example, Hsu states: “Examples of transparent, electrically insulating substrates 52 and 58 include, but are in no way limited to, polyester film, glass, and polycarbonate plastic. One example of a transparent, electrically insulating adhesive is 3M #8142. Examples of substantially transparent conductors include, but are not limited to, Indium Tin Oxide (ITO), transparent conductive plastic, and silver, gold, aluminum alloys.” (Hsu at 4:53-59). (*See also* Day Dep. Tr. 90:13-15).

403. It is therefore my opinion that Hsu discloses this limitation.

(j) Claim [7] - “The touch panel as recited in claim 1, wherein the capacitive sensing medium is a mutual capacitance sensing medium”

404. As described above in connection with claim [1F], both Gillespie and Gerpheide disclose a mutual capacitance sensing medium. Because these two U.S. Patent documents were expressly incorporated by reference into the disclosure of Hsu, it is my opinion that Hsu discloses this limitation. Mr. Day, a named co-inventor of Hsu, agrees that both of these references describe a mutual capacitance touch sensing system and that mutual capacitance was intended to work with the transparent sensor described in Hsu. (*See, e.g.*, Day Dep. Tr. 104:19-105:11; 106:2-108:10; 115:13-116:20; 118:23-119:1).

405. It is therefore my opinion that Hsu discloses this limitation.

SUBJECT TO PROTECTIVE ORDER
CONTAINS HIGHLY CONFIDENTIAL – ATTORNEYS’ EYES ONLY INFORMATION

406. Even if Hsu did not disclose a mutual capacitance sensing medium, such a sensing medium would have been obvious to one of ordinary skill in the art at the time the invention described in the ‘607 patent was made. *See* § (X)(A)(1)(j) above.

(k) Claim [8] -- “The touch panel as recited in claim 7, further comprising a virtual ground charge amplifier coupled to the touch panel for detecting the touches on the touch panel”

407. Hsu discloses a virtual ground charge amplifier (e.g., charge-integrator circuits 44-1 through 44-n of FIG. 3 of Gillespie) coupled to the touch panel for detecting the touches on the touch panel.

408. Gillespie states that “the capacitance at each touch sensor array 22 node is measured simultaneously using charge integrator circuits 44-1 through 44-n . Charge-integrator circuits 44-1 through 44-n serve to inject charge into the capacitances 42-1 through 42-n, respectively, and to develop an output voltage proportional to the capacitance sensed on the corresponding X matrix line. Thus charge-integrator circuits 44-1 through 44-n are shown as bidirectional amplifier symbols. Each charge-integrator circuit 44-1 through 44-n is supplied with an operating bias voltage by bias-voltage generating circuit 46.” (*Id.* at 12:52-62).

409. It is therefore my opinion that Hsu discloses this limitation. *See also* § X(B)(2)(k).

410. Even if Hsu did not expressly or inherently disclose a virtual ground charge amplifier, it would have been obvious to one of ordinary skill in the art to use a virtual ground charge amplifier as one of the several ways that detection of touches on the touch panel could have been performed.

411. Hsu clearly understands the importance of the rejection of parasitic or stray capacitance in processing the signals from the touch panel, which is the most significant feature

**SUBJECT TO PROTECTIVE ORDER
CONTAINS HIGHLY CONFIDENTIAL – ATTORNEYS’ EYES ONLY INFORMATION**

of the virtual ground charge amplifier of the ‘607 patent. One such example of a virtual ground charge amplifier is that of Blonder et al., U.S. Patent No. 5,113,041 issued May 12, 1992 (“Blonder”). As shown in Figure 3a of Blonder, reproduced below, element 30 is a virtual ground charge amplifier coupled to the touch panel for detecting the touches on the touch panel. It would have been obvious to one of ordinary skill in the art to include the virtual ground charge amplifier of Blonder in the input device of Hsu as a predictable variant and a matter of simple design implementation in order, e.g., to reduce noise from stray capacitance.

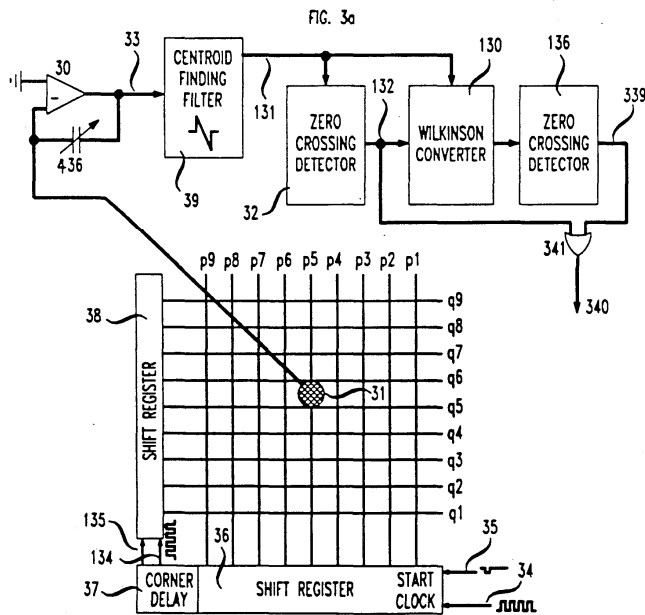

(1) **Claim [10A] – “A display arrangement having a screen for displaying a graphical user interface”**

412. Hsu discloses a display arrangement comprising a display (e.g., layer 60 of FIG.

2) having a screen for displaying a graphical user interface.

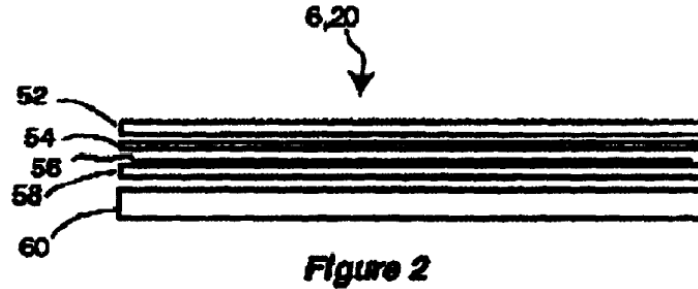

413. Hsu states: “The capacitive sensor can further be used as an input device for a graphical user interface, especially if overlaid on top of an active display device like an LCD screen to sense finger position (X/Y position) and contact area (Z) over the display.” (Hsu at Abstract).

414. It is therefore my opinion that Hsu discloses this limitation.

- (m) **Claim [10B] -- “a transparent touch panel allowing the screen to be viewed therethrough and capable of recognizing multiple touch events that occur at different locations on the touch panel at a same time and to output this information to a host device to form a pixilated image”**

415. As shown above in connection with claim 1, Hsu discloses a transparent touch panel allowing the screen to be viewed therethrough and capable of recognizing multiple touch events that occur at different locations on the touch panel at a same time and to output this information to a host device to form a pixilated image. *See* analysis for claim [1A].

416. It is therefore my opinion that Hsu discloses this limitation.

- (n) **Claim [10C] – “wherein the touch panel includes a multipoint sensing arrangement configured to simultaneously detect and monitor the touch events and a change in capacitive coupling associated with those touch events at distinct points across the touch panel”**

417. As shown above in connection with claim 1, Hsu discloses that the touch panel includes a multipoint sensing arrangement configured to simultaneously detect and monitor the

**SUBJECT TO PROTECTIVE ORDER
CONTAINS HIGHLY CONFIDENTIAL – ATTORNEYS’ EYES ONLY INFORMATION**

touch events and a change in capacitive coupling associated with those touch events at distinct points across the touch panel. *See* analysis for claim [1A].

418. It is therefore my opinion that Hsu discloses this limitation.

(o) Claim 10[D] – “wherein the touch panel comprises: a first glass member disposed over the screen of the display;

Hsu discloses a first glass member disposed over the screen of a display under both parties’ proposed claim constructions.

(i) Invalidity under Samsung’s Proposed Construction

Samsung contends that “glass member” should be given its plain and ordinary meaning to mean “glass” as opposed to plastic materials.

419. Hsu states: “Examples of transparent, electrically insulating substrates 52 and 58 include, but are in no way limited to, polyester film, glass, and polycarbonate plastic” (Id. at 4:53-59).

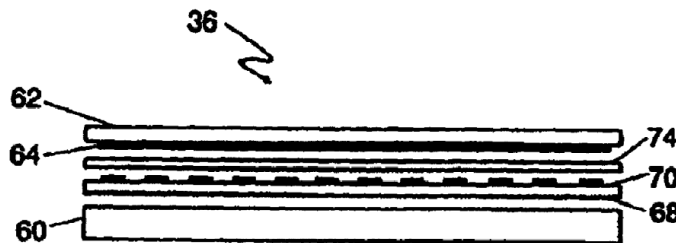

FIG. 5D

420. In connection with the two-dimensional sensor embodiment shown in FIG. 5D, Hsu states: “X-axis transparent, electrically insulating substrate 62 is the top surface that the finger or conductive object touches. The bottom side of the transparent, electrically insulating substrate 62 is the transparent conductor traces 64. A thin, transparent, preferably adhesive, insulator 74 separates X conductive traces 64 from Y conductive traces 70. Similar to X traces,

**SUBJECT TO PROTECTIVE ORDER
CONTAINS HIGHLY CONFIDENTIAL – ATTORNEYS’ EYES ONLY INFORMATION**

Y conductive traces are coated on transparent, electrically insulating substrate 68. Examples of transparent substrates 62 and 68, insulator 74, and conductive layers 64 and 70 have been described for FIG. 2 and are equally applicable for the two-dimensional sensor.” (Id. at 7:23-46). As such, the transparent substrates in Figure 5D can be composed of polyester film, glass, or polycarbonate plastic.

421. It is therefore my opinion that Hsu discloses this limitation under Samsung’s claim construction.

(ii) Invalidity under Apple’s Proposed Construction

422. Apple contends that “glass member” should be construed to include any glass or plastic material. Because the transparent substrates in Figure 5D can be composed of polyester film, glass, or polycarbonate plastic, it is my opinion that Hsu discloses this limitation under Apple’s proposed construction.

(p) Claim [10E] – “a first transparent conductive layer disposed over the first glass member”

423. As shown above, Hsu discloses a first transparent conductive layer disposed over the first glass member. *See* analysis for claims [10D] and [1A] - [1C].

(q) Claim [10F] – “the first transparent conductive layer comprising a plurality of spaced apart parallel lines having the same pitch and linewidths”

424. As shown above in connection with claim 1, Hsu discloses a first transparent conductive layer disposed over the first glass member. *See* analysis for claim [1B] – [1D].

(r) Claim [10G] – “a second glass member disposed over the first transparent conductive layer”

425. Hsu discloses a second glass member (e.g., insulator 74 of FIG. 5D) disposed over the first transparent conductive layer under both parties’ proposed constructions. *See* analysis for claim [10D].

**SUBJECT TO PROTECTIVE ORDER
CONTAINS HIGHLY CONFIDENTIAL – ATTORNEYS’ EYES ONLY INFORMATION**

(i) Invalidity under Samsung’s Proposed Construction

426. As described above, the transparent substrates of Figure 5D of Hsu can be glass or plastic. *See* analysis above with respect to claim [10D]. It is therefore my opinion that Hsu discloses this limitation under Samsung’s claim construction.

(ii) Invalidity under Apple’s Proposed Construction

427. As described above, the transparent substrates of Figure 5D of Hsu can be glass or plastic. *See* analysis above with respect to claim [10D]. It is therefore my opinion that Hsu discloses this limitation under Apple’s claim construction.

(s) Claim [10H] – “a second transparent conductive layer disposed over the second glass member

428. As shown above, Hsu discloses a first transparent conductive layer disposed over the first glass member. *See* analysis for claims [10D] and [1A] - [1C].

(t) Claim [10I] – “the second transparent conductive member comprising a plurality of spaced apart parallel lines having the same pitch and linewidths”

429. As shown above in connection with claim 1, Hsu discloses a first transparent conductive layer disposed over the first glass member. *See* analysis for claim [10D] and [1B] – [1D].

430. It is therefore my opinion that Hsu discloses this limitation.

(u) Claim [10J] – “the parallel lines of the second transparent conductive layer being substantially perpendicular to the parallel lines of the first transparent conductive layer”

431. As shown above in connection with claim 1, Hsu discloses a first transparent conductive layer disposed over the first glass member. *See* analysis for claim [10D] and [1B] – [1D].

(v) Claim [10K] -- “a third glass member disposed over the second conductive layer”

**SUBJECT TO PROTECTIVE ORDER
CONTAINS HIGHLY CONFIDENTIAL – ATTORNEYS’ EYES ONLY INFORMATION**

432. Hsu discloses a third glass member (e.g., top electrically insulating substrate 62 of FIG. 5D or FIG. 6) disposed over the second conductive layer under both parties’ proposed constructions.

433. Hsu states: “X-axis transparent, electrically insulating substrate 62 is the top surface that the finger or conductive object touches.” (Id. at 7:24-27).

434. Hsu also notes that “[a] number of additional alternative embodiments of the invention are possible. For example, electrical shielding may be required to isolate sensor traces from electrical noise that arises from electrical circuits that are present below the sensor. One preferred, but not limiting embodiment is shown in FIG. 6 on two-dimensional sensor 36. Layers 62-68 are the same art as described in FIG. 5D. Beneath transparent substrate 68, another layer of transparent insulator 74 attaches another layer of transparent conductor 78 and substrate 80.... Examples of materials suitable for transparent conductor 78 and substrate 80 have already been described in FIG. 2.” (Id. at 7:47-53).

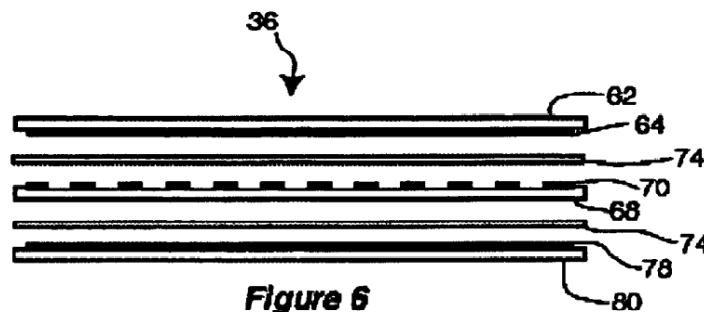

(i) Invalidity under Samsung’s Proposed Construction

435. As described above, the transparent substrates in Hsu can be glass or plastic. See analysis above with respect to claim [10D]. It is therefore my opinion that Hsu discloses this limitation under Samsung’s claim construction.

(ii) Invalidity under Apple’s Proposed Construction

**SUBJECT TO PROTECTIVE ORDER
CONTAINS HIGHLY CONFIDENTIAL – ATTORNEYS’ EYES ONLY INFORMATION**

436. As described above, the transparent substrates in Hsu can be glass or plastic. *See* analysis above with respect to claim [10D]. It is therefore my opinion that Hsu discloses this limitation under Apple’s claim construction.

(w) Claim [10L] – “one or more sensor integrated circuits operatively coupled to the lines”

437. Hsu discloses one or more sensor integrated circuits (e.g., X input processing block 38 and/or Y input processing block 40 and/or arithmetic unit 42 of FIG. 4) operatively coupled to the lines. *See* analysis above with respect to claim [1E].

(x) Claim [11] – “The display arrangement as recited in claim 10 further including dummy features disposed in the space between the parallel lines, the dummy features optically improving the visual appearance of the touch screen by more closely matching the optical index of the lines”

438. Hsu discloses dummy features (e.g., adhesive layer 54) disposed in the space between the parallel lines, the dummy features optically improving the visual appearance of the touch screen by more closely matching the optical index of the lines.

439. Hsu explains: “To improve transparency of the sensor a number of techniques can be utilized. First, substrates 52 and 58 and adhesive 54 can be chosen to have similar indices of refraction. This improves transparency by minimizing the distorting effects of light traveling through materials of different refraction indices. Second, employing the sensing art described U.S. Pat. No. 5,880,411 allows the use of high impedance output drivers. Hence, the resistivity of transparent conductor layer 56 can be relatively high and still be usable with such a sensing system. A high resistivity such as, but not limited to, $300 \cdot /\text{square}$ increases transparency of the substantially transparent conductor layer 56.” (Id. at 4:61-5:5). As such, the adhesive layer 54, which is disposed in the space between the conductive lines acts to optically improve the visual appearance of the touch screen by more closely matching the optical index of the lines.

**SUBJECT TO PROTECTIVE ORDER
CONTAINS HIGHLY CONFIDENTIAL – ATTORNEYS’ EYES ONLY INFORMATION**

440. It is therefore my opinion that Hsu discloses this limitation.

441. To the extent Hsu does not expressly or inherently disclose the claimed “dummy features,” such features would have been obvious to one of ordinary skill in the art at the time the ‘607 invention was made.

442. Hsu clearly contemplates a transparent input device positioned in front of an display, so it would have been obvious to incorporate “dummy features” that optically improve the visual appearance of the touchscreen by more closely matching the optical index of the lines, as taught by Perski ‘455 (*see, e.g.*, Perski ‘455 at 5), Morag (*see, e.g.*, Morag at 12:64-13:32), or Mackey (*see, e.g.*, Mackey at 8:17-39), in order to reduce the visual differences between the conducting and non-conducting areas and create a transparent touch screen with little or no visual distortions.

3. The ‘607 Patent is Invalid in View of Hsu

443. I have considered and compared asserted claims of the ‘607 patent to the claims and specification of Hsu, as described above. It is my opinion that Hsu anticipates claims 1-3, 6-8, 10, and 11 of the ‘607 patent. My opinions are supported by Exhibit 607-09, which is a claim chart that shows how Hsu discloses the limitations of the asserted claims in more detail.

F. [REDACTED]

444. [REDACTED]

[REDACTED]

[REDACTED]

[REDACTED]

[REDACTED]

**SUBJECT TO PROTECTIVE ORDER
CONTAINS HIGHLY CONFIDENTIAL – ATTORNEYS’ EYES ONLY INFORMATION**

[REDACTED]

[REDACTED]

445. [REDACTED]

[REDACTED]

[REDACTED]:

[REDACTED]

[REDACTED]

[REDACTED]

446. [REDACTED]

[REDACTED]

[REDACTED]

[REDACTED]

[REDACTED]

[REDACTED].

**SUBJECT TO PROTECTIVE ORDER
CONTAINS HIGHLY CONFIDENTIAL – ATTORNEYS’ EYES ONLY INFORMATION**

447. [REDACTED]

[REDACTED]

[REDACTED]

[REDACTED].

448. [REDACTED]

[REDACTED]

[REDACTED]

[REDACTED]

[REDACTED]

[REDACTED]

[REDACTED]

[REDACTED]

[REDACTED]

449. [REDACTED]

[REDACTED]

[REDACTED]

450. [REDACTED]

[REDACTED]

[REDACTED]

451. [REDACTED]

[REDACTED]

[REDACTED]

**SUBJECT TO PROTECTIVE ORDER
CONTAINS HIGHLY CONFIDENTIAL – ATTORNEYS’ EYES ONLY INFORMATION**

452. [REDACTED]

[REDACTED]

Q. [REDACTED]

[REDACTED]

[REDACTED]

[REDACTED]

[REDACTED]

[REDACTED]

[REDACTED]

[REDACTED]

[REDACTED]

[REDACTED]

[REDACTED]

[REDACTED]

453. [REDACTED]

[REDACTED]

[REDACTED]

[REDACTED]

[REDACTED]

454. [REDACTED]

[REDACTED]

[REDACTED]

[REDACTED]

**SUBJECT TO PROTECTIVE ORDER
CONTAINS HIGHLY CONFIDENTIAL – ATTORNEYS’ EYES ONLY INFORMATION**

455. [REDACTED]

[REDACTED]

[REDACTED]

[REDACTED]

456. [REDACTED]

[REDACTED]

- [REDACTED]
- [REDACTED]

[REDACTED]

457. [REDACTED]

[REDACTED]

- [REDACTED]
- [REDACTED]
- [REDACTED]
- [REDACTED]

[REDACTED]

[REDACTED]

[REDACTED]

458. [REDACTED]

[REDACTED]

[REDACTED]

[REDACTED]

[REDACTED]

[REDACTED]

[REDACTED]

[REDACTED]

XI. THE COPYING AND DERIVATION FROM SONY’S SMARTSKIN IS MATERIAL TO THE PATENTABILITY OF THE ’607 PATENT

459. During prosecution of the ’607 patent, the Examiner “considered” the SmartSkin reference along with over 300 other references. In light of the fact that the SmartSkin reference was “buried” in these over 300 references, it is not surprising that the Examiner did not appreciate the significance of SmartSkin. If the Examiner had known the real story, the outcome would have been very different.

460. [REDACTED]

[REDACTED]

[REDACTED]

[REDACTED]

[REDACTED]

[REDACTED]

[REDACTED]

[REDACTED]

[REDACTED]

[REDACTED]

XII. SUMMARY OF OPINIONS OF INVALIDITY OF THE ‘129 PATENT

A. The ‘129 Patent is Invalid due to Anticipation and/or Obviousness.

461. It is my opinion that claims 1-3, 5, 7, 9-12, 14, 16-19, 21, 22, 24-26, and 28 of the '129 patent ("Asserted Claims") are anticipated and rendered obvious in light of the prior art identified below and analyzed in the corresponding invalidity charts attached as exhibits to this report as Exhibits 129-1 through 129-5. I outline my analysis and explain why each prior art reference invalidates the '129 patent below and in the attached invalidity charts, all of which I incorporate by reference into this report, including all documents cited therein. I also incorporate by reference Samsung's Invalidity Contentions served October 7, 2011, and Samsung's Supplemental Invalidity Contentions for the '129 Patent (attached as Exhibit 129-6), and all patents and documents cited therein.

462. Because my detailed opinions regarding invalidity for each prior art reference is in the corresponding Exhibits 129-1 through 129-5, below I incorporate and reference those charts as my substantive opinions for each prior art reference to avoid redundancy and to save paper to the extent I can.

463. It is my opinion that each of the Asserted Claims is anticipated by one or more of the following references:

- The Cirque GlidePoint System ("GlidePoint")
- U.S. Patent No. 5,565,658 ("Gerpheide '658")
- The Whirlpool Velos Touch Sensor System ("Velos")
- U.S. Patent No. 7,932,898 ("Philipp '898")
- PCT Patent Application Publication WO 2005/114369 ("Hotelling '369")

**SUBJECT TO PROTECTIVE ORDER
CONTAINS HIGHLY CONFIDENTIAL – ATTORNEYS’ EYES ONLY INFORMATION**

464. It is also my opinion that each of the above prior art references render all of the Asserted Claims obvious to a person of ordinary skill in the art either alone or in combination with the other patents I identify in the attached invalidity exhibits, including the following:

- U.S. Patent No. 5,083,118 ("Kazama '118")
- Gerpheide '658
- Philipp '898
- GlidePoint
- Velos
- U.S. Patent No. 7,053,886 ("Shin '886")
- And all other patents identified in Exhibits 129-1 through 129-5.

465. Additionally, it is my opinion that the term "substantially electrically isolate" used in claims 3, 12, 19, 22, and 24-26 and 28 is indefinite and therefore those claims are invalid for indefiniteness as explained below.

XIII. TECHNICAL BACKGROUND PERTINENT TO THE 129 PATENT

466. If asked to testify at the hearing or other proceeding in this Investigation, I may provide a tutorial concerning certain technology relevant to the '129 patent, including the matters set forth in this report. For purposes of any such tutorial, I may use demonstratives, such as charts, overheads, videos, computer graphics, samples, and other visual or audio aids, and may address the topics below, as well as other basic aspects of touchscreens used in computers, PDAs, mobile phones, smart phones, and other communications devices, including the hardware and software for these devices. Any such tutorial may also address any technical issues that Apple's experts raise in their reports.

SUBJECT TO PROTECTIVE ORDER
CONTAINS HIGHLY CONFIDENTIAL – ATTORNEYS' EYES ONLY INFORMATION

467. Generally, the '129 Patent is directed to a two-layer touch sensor panel with electrodes oriented in an "X" direction on one layer and electrodes oriented in the "Y" direction on another layer. The electrodes are separated by a dielectric. The bottom set of electrodes are made wider than the top set of electrodes. In this configuration, the wider bottom electrodes act as a shield between the underlying circuitry and the narrow top electrodes and shield the narrow top electrodes from underlying noise. Several asserted claims of the '129 patent specify that the source of the noise is an LCD display. Some of the Asserted Claims require that the bottom electrodes are drive electrodes and the top electrodes are sense electrodes. Below I provide a general overview of touch sensor panel technology and how the features of the '129 patent were known well before January 3, 2006.

468. I also incorporate the above sections regarding the technology surrounding the '607 patent into this section regarding the '129 patent. The '607 patent application was incorporated by reference into the '129 patent and its application, and I understand that by incorporating it by reference, it is as if it were a part of the '129 patent and its disclosure.

A. Capacitive Touch Sensing

469. Touch sensing technologies have utilized several approaches to detect, locate and identify touch on a sensor array. These technologies included capacitive, resistive, image based touch sensing, interrupting light beams and surface acoustic wave approaches.

470. Capacitive touch-sensing technology, in particular, has been found to be particularly accurate using components requiring little power or complexity.

471. The concept of capacitive touch sensing can be visualized with parallel plate capacitors. Such capacitors increase in proportion to the area of the parallel plates, and increase in proportion to the proximity of the two plates.

**SUBJECT TO PROTECTIVE ORDER
CONTAINS HIGHLY CONFIDENTIAL – ATTORNEYS’ EYES ONLY INFORMATION**

472. A human touch, with a finger, for example, provides additional capacitance in proximity to an electrode. Self capacitance measurements of that electrode measure the capacitance of the electrode relative to ground. When a person touches an electrode or comes in proximity to the electrode, the capacitance of that electrode to ground increases. Such an approach has been known for over 40 years, as depicted in US Patent 3,696,409. Figure 2 illustrates such a touchscreen on the faceplate of a television or display:

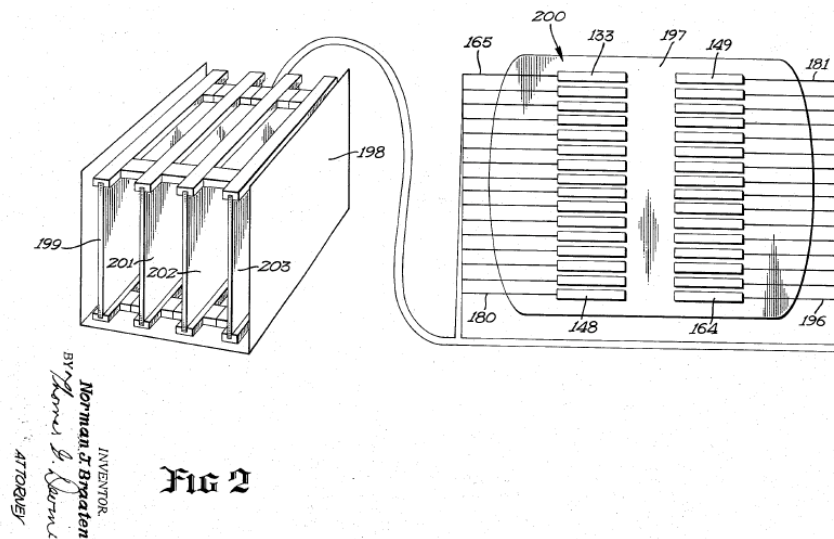

B. Mutual Capacitance

473. Mutual capacitance provides another approach to capacitive touch sensing. Mutual capacitance differs from self-capacitance in several important respects. The first is that the capacitance from one electrode to another is altered by the proximity of a touch. Touch sensing by mutual capacitance has been known for nearly half a century. US Patent 3,382,588 filed in 1965 shows a transparent touchscreen on a television based on mutual capacitance:

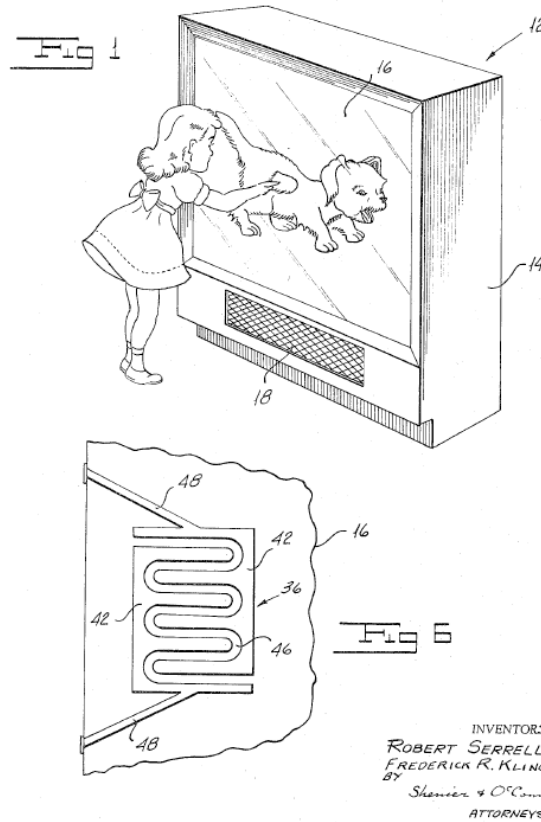

C. Coupling of Sensors at Intersections

474. The second important distinction is that mutual capacitance variations between row and column electrodes can identify unique locations on a touch-sensing array. This structure was disclosed in US Patent 4,733,222, filed in 1986:

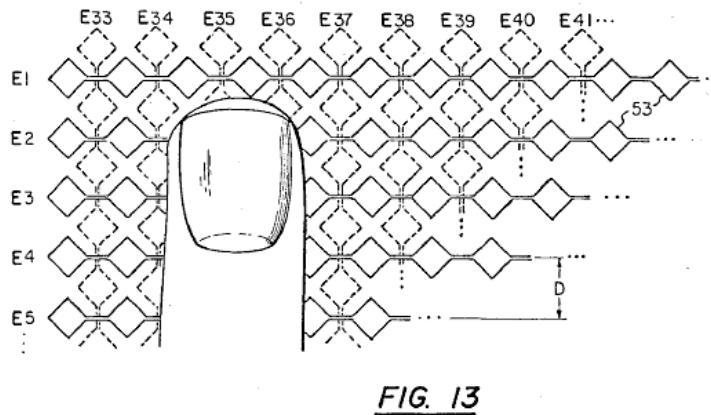

**SUBJECT TO PROTECTIVE ORDER
CONTAINS HIGHLY CONFIDENTIAL – ATTORNEYS’ EYES ONLY INFORMATION**

475. The structure of the figure labeled 13 above worked by coupling the column pads that were wide near intersections to a nearby finger as illustrated. This configuration increased the capacitance of the column electrodes near the finger. The finger, in addition, coupled to nearby row traces and associated nearby row intersections. This coupling increased the capacitance from the finger to the row electrodes in the vicinity of the finger. These two capacitors in series increased the mutual capacitance from column electrodes near the finger to the row electrodes near the finger. By scanning the drive electrodes, and measuring all the sense electrodes, it was possible to determine all the concurrent touch locations on the touch panel. As a result, this patent filed in 1986 disclosed not only mutual capacitance, but also the row and column structures that enable concurrent sensing of multiple concurrent touches.

476. Around the time of the ‘129 invention, the use of indium tin oxide (ITO) transparent conductor was widespread. In fact, the success of LCD television depends in large part on the use of ITO transparent conductors. Those of ordinary skill were familiar with ITO and its use in LCD flat panel displays, which implement row and column electrodes similar to those employed by touch sensing apparatus.

477. Shielding and interference reduction in mutual capacitance touch sensors has been known for over 15 years. US Patent No. 5,565,658 assigned to Cirque Corporation entitled “Capacitance-based proximity with interference rejection apparatus and methods” discloses underlying drive traces much wider than the sense traces. The drive traces shield the sense traces from electromagnetic interference:

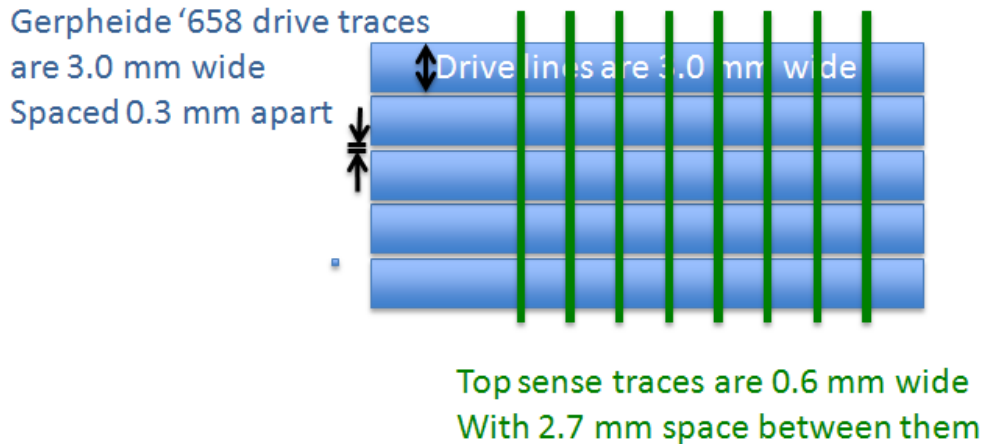

478. LCD's have row and column electrodes and produce noise when carrying signals for the LCD display. This noise can interfere with the operation of the touchscreen, and should be minimized, for example by shielding. While an entire layer could be dedicated to shielding, the touch sensor would be more transparent and less complex if the drive layer were widened so as to increase the shielding, as shown above in Gerpheid '658.

D. LCD Modulated VCOM Noise and Approaches to Shielding

479. One source of noise in the LCD is a modulated VCOM signal. VCOM was commonly modulated to reduce the maximum voltage required for LCD drive. VCOM modulates the reference voltage of the LCD. Modulated VCOM is broadly used throughout the industry for smaller displays. Modulating VCOM offers the benefit of lower drive voltages for similar performance. Most notebooks and large-screen LCD's use a constant VCOM due to the power drive requirements for the highly capacitive VCOM electrode. It would have been obvious to one of ordinary skill in the art to use modulated VCOM to lower supply voltages and provide benefits for smaller displays, especially since such LCD's had been in widespread use since the 1990's.

480. VCOM comprises a large capacitance electrode and thus requires a lot of power to modulate. This larger modulation power leads to more noise that has to be shielded compared

SUBJECT TO PROTECTIVE ORDER
CONTAINS HIGHLY CONFIDENTIAL – ATTORNEYS’ EYES ONLY INFORMATION

to constant VCOM. (Active Matrix Liquid Crystal Displays, Fundamentals and Applications, Willem den Boer, p. 90-92). This larger AC power dissipation has a large effect on adjacent touch sensing and associated signal to noise levels.

481. One source of noise in the LCD is the VCOM signal. VCOM is a modulated signal that represents the common mode voltage of the LCD. VCOM has a large capacitance to the electrode and thus requires a lot of power to modulate. This larger modulation power leads to more noise that has to be shielded compared to constant VCOM. (Active Matrix Liquid Crystal Displays, Fundamentals and Applications, Willem den Boer, p. 91). This larger AC power dissipation has a larger effect on adjacent touch sensing and associated signal to noise levels.

E. Low-Impedance Drivers and Associated Shielding

482. Low impedance drivers were used for VCOM, and for driving on touch sensing. It was commonly known to those in the art that a low-impedance powered electrode provides nearly as good a shield as a ground electrode, due to the fact that the low-impedance power supply is bypassed with bypass capacitors to ground that shunt the AC power to ground with low impedance. This shunting of AC power provides a strong connection from any received noise signals to ground. The result is that a low impedance driver provides nearly as much shielding as a ground path for the purposes of noise shielding. I have personally designed several patented integrated circuit package architectures that utilize this principle to provide sensitive signal shielding using both powered drive electrodes as well as ground electrodes to protect sensitive signals.

483. Shielding by any conductor is a function of the geometry of the conductor, as required by Maxwell’s Laws. For a given noise input and material, the geometry of the

**SUBJECT TO PROTECTIVE ORDER
CONTAINS HIGHLY CONFIDENTIAL – ATTORNEYS’ EYES ONLY INFORMATION**

conductor provides the structure needed to disclose the degree of shielding. Those of ordinary skill in the art can infer the degree of noise protection based on the configuration of the shielding for a given aggressor noise signal and a set of sensitive signal traces.

F. Market Need for Transparent Touchscreen

484. In the early 2000’s, the market need for transparent touchscreens skyrocketed. The Nintendo DS game was a high-volume product utilizing a transparent touchscreen. After the Nintendo DS was released in late 2004, there were strong market needs for transparent touchscreens that could be deployed in other consumer products. This market need naturally led those of skill in the art to combine touchpads such as the GlidePoint and associated Gerpheid patents with an LCD display. At the time of invention of the ‘129, there were many transparent touchscreens already developed in response to this market need.

G. Shielding in a Mutual Capacitance Sensor

485. Whether drive electrodes are on the bottom (near the display) or the top (near the user) of a mutual capacitance touch sensor is generally dictated by design considerations such as noise. One principal goal of mutual capacitive touchscreens is to improve the signal-to-noise ratio by reducing noise and increasing signal quality. In particular, as explained more fully later in this Report, it has been well-known in the art for many years that drive electrodes will shield sense electrodes from noise, because when a drive electrode is not being driven, it will act as a conductive screen to electromagnetic noise. This shielding property is inherent in any conductor. Because an electromagnetic signal prefers to travel through a conductor rather than through an

**SUBJECT TO PROTECTIVE ORDER
CONTAINS HIGHLY CONFIDENTIAL – ATTORNEYS’ EYES ONLY INFORMATION**

insulator such as air, when an electromagnetic signal traveling through an insulator hits a conductor, it will disperse throughout the conductor rather than simply moving through it.⁵

486. Because it is well-known that drive electrodes will tend to shield sense electrodes from noise, whether a touch screen designer places the drive electrodes in a mutual capacitance sensor on the bottom (near the display) or the top (near the user) will depend on whether the designer is more concerned with noise on the sense electrodes originating from above the sensor or below it.

487. For example, if a separate shielding layer called a "conductive ground plane" is placed below a mutual capacitance touch sensor, thus shielding noise from below the display, the touch screen designer may be more concerned with noise from above the display, and therefore may place the drive electrodes on top of the sense electrodes. An example of a separate ground plane used as a shield is shown below in figure 4 of U.S. Patent No. 4,733,222:

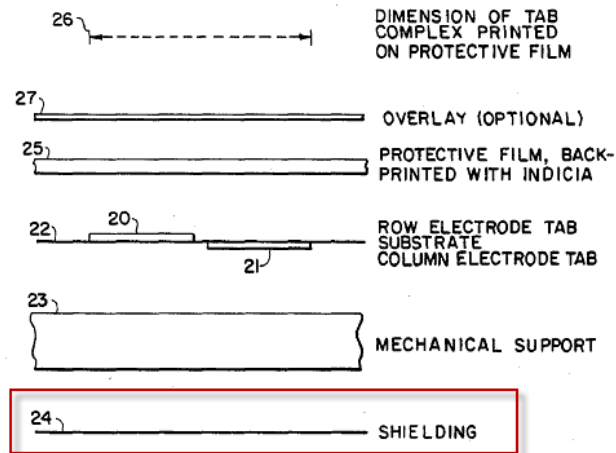

FIG. 4

⁵ The use of one conductor to shield another conductor from electromagnetic noise has been known for at least 175 years. For example, in 1836 when English physicist Michael Faraday created a conductive box now known as a "Faraday cage" to shield the box's contents from electromagnetic noise. Faraday cages are now widely used to house sensitive electronics such as computers to shield these electronics from electromagnetic noise.

**SUBJECT TO PROTECTIVE ORDER
CONTAINS HIGHLY CONFIDENTIAL – ATTORNEYS’ EYES ONLY INFORMATION**

488. On the other hand, if a touch screen designer is concerned about the thickness of the touch screen build—for example, if the touch screen is used in a small portable device such as a smartphone or tablet computer—the designer may choose to forgo a separate shield layer to make the touch sensor better suited for a mobile device. (Omitting a separate shield layer will also tend to have the additional benefit of increasing transparency of the touch screen.) Without a separate shield layer, the designer is more likely to be concerned with noise from the display itself (below the touch sensor) than with noise from above the display. The most natural response to this concern would be to use the built-in shielding layer already inherent in a two-layer mutual capacitance touch sensor—the drive electrode layer—as a noise shield by placing the drive electrodes below the sense electrodes.

XIV. OVERVIEW OF 129 PATENT AND ASSERTED CLAIMS

A. Summary

489. The ‘129 patent, entitled “Double-Sided Touch-Sensitive Panel with Shield and Drive Combined Layer” was filed on January 3, 2007, and issued on April 5, 2011. The '129 patent has two named inventors: Steve Hotelling and Brian Land. The patent issued from U.S. Patent Application No. 11/650,182 ("the '182 Application"), filed January 3, 2007. The '129 Patent does not claim priority to any earlier patent application or provisional application.

490. The '129 Patent discloses capacitive touch sensor panels having rows and columns separated by a substrate. '129 Patent at 1:7-10. These rows can be widened for shielding purposes and for providing a uniform appearance. *Id.* at 3:24-27; *see also id.* at 11:57-16:6 (claims 1-29).

491. The "Background of the Invention" section describes prior art touch screens and acknowledges that "[t]ouch screens, in particular, are becoming increasingly popular," and states that "[t]ouch screens can include a touch panel, which can be a clear panel with a touch-sensitive

SUBJECT TO PROTECTIVE ORDER
CONTAINS HIGHLY CONFIDENTIAL – ATTORNEYS’ EYES ONLY INFORMATION

surface." '129 Patent at 1:17-21. In addition, the "Background of the Invention" section states that "[c]apacitive touch sensor panels can be formed from rows and columns of traces on opposite sides of a dielectric," and that "[c]onventional touch panels for use over display devices have typically used a top layer of glass upon which transparent column traces of indium tin oxide (ITO) or antimony tin oxide (ATO) have been etched, and a bottom layer of glass upon which row traces of ITO have been etched." *Id.* at 1:44-53. Furthermore, unconventional touch panels, "[t]he top and bottom glass layers are separated by a clear polymer spacer that acts as a dielectric between the row and column traces." The traces on both the top and bottom glass layers can have a spacing of about 5 mm." *Id.* at 1:58-62. In such conventional touch panels, "a stimulus can be applied to one row with all other rows held at DC voltage levels," creating "an analog channel output value for every pixel (row and column) in the panel." corresponding to the amount of touch or hover detected at a given location *Id.* at-2:14-18.

492. These prior art conventional touch screens may generate noise "when a transparent capacitive touch sensor panel is bonded to a liquid crystal display (LCD)," because "a modulated Vcom layer in the LCD can couple onto the columns of the sensor panel, causing noise to appear on the columns." *Id.* at 2:37-40.

493. The '129 Patent attempts to address this problem. The '129 Patent allows "the row traces can be widened to shield the column traces from a modulated Vcom layer." *Id.* at 2:59-60. Thus, as described in the "Summary of the Invention" section of the '129 Patent:

The rows of the DITO substrate can also be widened for shielding purposes and for providing a uniform appearance according to embodiments of this invention. To prevent the capacitive coupling of a modulated Vcom layer onto the columns of the substrate, the rows may be widened. The number of rows does not change, but they can be much wider, leaving only about 30 microns of space between them. Because these wider rows are not isolated but are instead either held at a DC voltage or stimulated with a stimulation

SUBJECT TO PROTECTIVE ORDER
CONTAINS HIGHLY CONFIDENTIAL – ATTORNEYS’ EYES ONLY INFORMATION

voltage, these wider rows act as a shield, preventing a modulated Vcom layer from capacitively coupling onto the columns. In addition, because of the narrow spacing between them, the wide rows provide a uniform appearance. Thus, shielding, modulation and a uniform appearance can be obtained from a single layer of ITO.

'129 Patent at 3:25-38.

494. The '129 patent devotes little discussion to the claimed methods and apparatuses for shielding a capacitive touch panel. In fact, only one paragraph of the disclosure of the '129 Patent actually discusses any specifics regarding widening of drive rows to shield sense columns from display noise. *See id.* at 10:52-11:8. Fig. 9 and the corresponding discussion discuss the '129 patent's solution to the noise problem identified in prior art conventional touch screens. The widened columns "prevent the capacitive coupling of a modulated Vcom layer onto columns 938, rows 936 may be widened as showing in Fig. 9. *See id.* at Fig. 9; *id.* at 10:52-58. The wider rows "act as a shield, preventing a modulated Vcom layer from capacitively coupling onto columns. *Id.* at 63-65.

495. Figure 9 of the '129 Patent, described as "an exemplary DITO substrate 900 (with its thickness greatly exaggerated for purposes of illustration only) illustrating widening of rows 936 for shielding purposes and for providing a uniform appearance according to embodiments of this invention," '129 Patent at 52-56, is shown below:

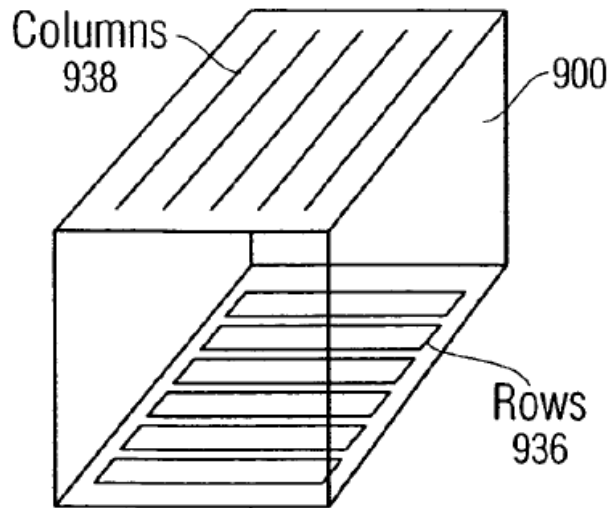

Fig. 9

496. Notably, the '129 patent does not provide a detailed description as to how a capacitive touch panel is to be integrated into the "exemplary mobile telephone" and the "exemplary digital audio/video player" shown in Figs. 10a and 10b. *See, e.g.*, Fig. 10a and 10b. The only description relating to shielding in the "exemplary mobile telephone" and "exemplary digital audio/video player" appears at col. 11 lines 20-48:

FIG. 10a illustrates an exemplary mobile telephone 1136 that can include capacitive touch sensor panel 1124 and flex circuit 1134 capable of connecting to both sides of the substrate according to embodiments of this invention. . . . Furthermore, sensor panel 1134 can be fabricated with wide rows to provide modulated Vcom layer shielding as well as uniform appearance. FIG. 10b illustrates an exemplary digital audio/video player 1138 that can include capacitive touch sensor panel 1124 and flex circuit 1134 capable of connecting to both sides of the substrate according to embodiments of this invention. . . . Furthermore, sensor panel 1134 can be fabricated with wide rows to provide modulated Vcom layer shielding as well as uniform appearance. The mobile telephone and digital audio/video player of FIGs. 10a and 10b can advantageously benefit from sensor panel 1124 because a single, thinner, smaller-sized sensor panel can be used, and only a single

SUBJECT TO PROTECTIVE ORDER
CONTAINS HIGHLY CONFIDENTIAL – ATTORNEYS’ EYES ONLY INFORMATION

layer of ITO is needed to provide shielding and a uniform appearance. The overall effect is reduced product size and manufacturing costs.

497. The '129 patent discusses the alleged problem of noise and the use of wide drive rows as shielding. However, there is discussion of specific requirements or improvements necessary to implement a capacitive touch sensor panel with widened drive rows.

498. The '129 Patent does not describe any unique requirements for implementing a capacitive touch sensor panel above a modulated Vcom display. The patent discusses the alleged problem of noise from this display and the use of wide drive rows as shielding, but nowhere in the patent is there any discussion of specific requirements or improvements necessary to implement a capacitive touch sensor panel with widened drive rows.

499. The patent has twenty-nine claims, nine of which are independent claims. Independent claims 1, 8, 9, and 10 are apparatus claims, and independent claims 17, 21, 24, 25, and 26 are method claims.

B. The Asserted Claims

500. I understand that claims 1-3, 5-12, 14-19, 21-22, and 24-28 of the '129 Patent are at issue in this Investigation. Claims 1, 8, 9, and 10 are independent apparatus claims. Claims 17, 21, 24, 25, and 26 are independent method claims. The remaining asserted claims are dependent claims. These claims are reproduced in their entirety below. (The bracketed letter designations do not appear in the original claims and are added only for clarity.)

1[a]. A capacitive touch sensor panel, comprising:

[b] a first set of traces of conductive material arranged along a first dimension of a two-dimensional coordinate system, the first set of traces having one or more widths including a maximum width; and

[c] a second set of traces of the conductive material spatially separated from the first set of traces by a dielectric and arranged along a second dimension of the two-dimensional

SUBJECT TO PROTECTIVE ORDER
CONTAINS HIGHLY CONFIDENTIAL – ATTORNEYS’ EYES ONLY INFORMATION

coordinate system, the second set of traces having one or more widths including a minimum width;

[d] wherein the minimum width of the second set of traces is substantially greater than the maximum width of the first set of traces at least at an intersection of the first and second sets of traces to provide shielding for the first set of traces; and

[e] wherein sensors are formed at locations at which the first set of traces intersects with the second set of traces while separated by the dielectric.

2. The capacitive touch sensor panel of claim 1, further comprising a liquid crystal display (LCD) adjacent to the touch sensor panel, the LCD emitting a modulated Vcom signal, and the second set of traces configured for shielding the first set of traces from the modulated Vcom signal.

3. The capacitive touch sensor panel of claim 1, wherein the second set of traces are widened to substantially electrically isolate the first set of traces from a liquid crystal display (LCD).

5. The capacitive touch sensor panel of claim 1, further comprising a computing system that incorporates the sensor panel.

7. The capacitive touch sensor panel of claim 5, further comprising a digital audio player that incorporates the computing system.

9. [a] A digital audio player having a capacitive touch sensor panel, the touch sensor panel comprising:

[b] a first set of traces of conductive material arranged along a first dimension of a two-dimensional coordinate system, the first set of traces having one or more widths including a maximum width; and

[c] a second set of traces of the conductive material spatially separated from the first set of traces by a dielectric and arranged along a second dimension of the two-dimensional coordinate system, the second set of traces having one or more widths including a minimum width;

[d] wherein the minimum width of the second set of traces is substantially greater than the maximum width of the first set of traces at least at an intersection of the first and second sets of traces to provide shielding for the first set of traces; and

[e] wherein sensors are formed at locations at which the first set of traces intersects with the second set of traces while separated by the dielectric.

SUBJECT TO PROTECTIVE ORDER
CONTAINS HIGHLY CONFIDENTIAL – ATTORNEYS’ EYES ONLY INFORMATION

10[a]. A capacitive touch sensor panel, comprising:

[b] sense traces having one or more widths including a maximum width; and

[c] drive traces spatially separated from the sense traces by a dielectric, the drive traces having one or more widths including a minimum width, the minimum width of the drive traces being substantially greater than the maximum width of the sense traces at least at an intersection of the sense and drive traces to provide shielding for the sense traces;

[d] wherein sensors are formed at locations at which the sense traces intersect with the drive traces while separated by the dielectric.

11. The capacitive touch sensor panel of claim 10, further comprising a liquid crystal display (LCD) adjacent to the touch sensor panel, the LCD emitting a modulated Vcom signal, and the drive traces configured for shielding the sense traces from the modulated Vcom signal.

12. The capacitive touch sensor panel of claim 10, wherein the drive traces are widened to substantially electrically isolate the sense traces from a liquid crystal display (LCD).

14. The capacitive touch sensor panel of claim 10, further comprising a computing system that incorporates the sensor panel.

16. The capacitive touch sensor panel of claim 14, further comprising a digital audio player that incorporates the computing system.

17[a]. A method for shielding a capacitive touch sensor panel from capacitive coupling of modulated signals, comprising:

[b] forming a first set of sense traces having one or more widths including a maximum width;

[c] orienting the sense traces along a first dimension of a two-dimensional coordinate system;

[d] forming a second set of drive traces spatially separated from the first set of sense traces by a dielectric, the second set of drive traces having one or more widths including a minimum width, the minimum width of the drive traces being substantially greater than the maximum width of the sense traces at least at an intersection of the first and second sets of traces to provide shielding for the sense traces; and

[e] orienting the drive traces along a second dimension of the two-dimensional coordinate system to form sensors at locations

SUBJECT TO PROTECTIVE ORDER
CONTAINS HIGHLY CONFIDENTIAL – ATTORNEYS’ EYES ONLY INFORMATION

at which the sense traces intersect with the drive traces while separated by the dielectric.

18. The method of claim 17, further comprising affixing a liquid crystal display (LCD) adjacent to a side of the touch sensor panel closest to the drive traces, the LCD capable of emitting a modulated Vcom signal.

19. The method of claim 17, further comprising widening the drive traces to substantially electrically isolate the sense traces from a liquid crystal display (LCD).

21[a]. A method for shielding a capacitive touch sensor panel from a source of capacitive coupling, comprising:

[b] forming a first set of traces further from the source of capacitive coupling than a second set of traces, the first set of traces configured for sensing changes in mutual capacitance, the first set of traces having one or more widths including a maximum width;

[c] orienting the first set of traces along a first dimension of a two-dimensional coordinate system;

[d] forming the second set of traces closer to the source of capacitive coupling than the first set of traces and spatially separated from the first set of traces by a dielectric, the second set of traces having one or more widths including a minimum width, the minimum width of the second set of traces being substantially greater than the maximum width of the first set of traces at least at an intersection of the first and second sets of traces to provide shielding for the first set of traces, the second set of traces configured for being driven by low impedance driver outputs; and

[e] orienting the second set of traces along a second dimension of the two-dimensional coordinate system to form sensors at locations at which the first set of traces intersects with the second set of traces while separated by the dielectric.

22. The method of claim 21, further comprising widening the drive traces to substantially electrically isolate the sense traces from a liquid crystal display (LCD).

24[a]. A capacitive touch sensor panel, comprising:

[b] sense traces formed on a first layer and arranged along a first dimension of a two-dimensional coordinate system; and

[c] drive traces formed on a second layer spatially separated from the first layer by a dielectric, the drive traces arranged along a second dimension of the two-dimensional coordinate system;

SUBJECT TO PROTECTIVE ORDER
CONTAINS HIGHLY CONFIDENTIAL – ATTORNEYS’ EYES ONLY INFORMATION

[d] wherein the drive traces are widened as compared to the sense traces to substantially cover the second layer except for a gap between adjacent drive traces so as to substantially electrically isolate the sense traces from a liquid crystal display (LCD);

[e] wherein sensors are formed at locations at which the sense traces intersect with the drive traces while separated by the dielectric; and

[f] wherein each of the drive traces is of a substantially constant width.

25[a]. A method for shielding a capacitive touch sensor panel from coupling of modulated signals, comprising:

[b] forming a first set of sense traces on a first layer;

[c] orienting the sense traces along a first dimension of a two-dimensional coordinate system;

[d] forming a second set of widened drive traces on a second layer spatially separated from the first layer, the drive traces widened as compared to the sense traces to substantially cover the second layer except for a gap between adjacent drive traces so as to substantially electrically isolate the first set of sense traces from a liquid crystal display (LCD); and

[e] orienting the drive traces along a second dimension of the two-dimensional coordinate system to form sensors at locations at which the sense traces intersect with the drive traces;

[f] wherein each of the drive traces is of a substantially constant width.

26[a]. A touch sensitive computing system, comprising:

[b] a touch processor;

[c] a display;

[d] a touch sensor panel adjacent to the display and coupled to the touch processor, the touch sensor panel including

[e] sense traces formed on a first layer, and

[f] drive traces formed on a second layer spatially separated from the first layer, the drive traces widened as compared to the sense traces to substantially cover the second layer except for a gap between adjacent drive traces so as to substantially electrically isolate the sense traces from a liquid crystal display (LCD),

[g] wherein sensors are formed at locations at which the sense traces intersect with the drive traces; and

[h] wherein each of the drive traces is of a substantially constant width.

28. The touch sensitive computing system of claim 26, wherein the computing system is incorporated into a media player.

**SUBJECT TO PROTECTIVE ORDER
CONTAINS HIGHLY CONFIDENTIAL – ATTORNEYS’ EYES ONLY INFORMATION**

C. The Prosecution History

501. I have reviewed the prior art cited against the claims of the ‘129 patent by the United States Patent and Trademark Office (“USPTO”) during prosecution. The USPTO did not consider *any of the prior art* that I address in this report. In addition, the USPTO did not have the benefit of the testimony of Samuel Brunet, of Atmel, given in support of the technical documentation of the Velos products. Mr. Brunet is also a named inventor of U.S. Patent No. 7,932,898.

502. The '129 Patent issued from U.S. Patent Application 11/650,182 ("the '182 Application"), which was filed on January 3, 2007.

1. The Claims as Originally Filed

503. '182 Application contained twenty claims, including six independent claims (claims 1, 7-9, 15, and 19). Claims 1 and 9 in the '182 Application read as follows:

1. A capacitive touch sensor panel, comprising:
 - a substrate formed from a dielectric material;
 - a first set of non-overlapping traces of conductive material located on a first side of the substrate and arranged along a first dimension of a two-dimensional coordinate system; and
 - a second set of non-overlapping traces of the conductive material located on a second side of the substrate and arranged along a second dimension of the two-dimensional coordinate system;wherein the second set of traces are widened as compared to the first set of traces to provide shielding for the first set of traces; and
 - wherein sensors are formed at locations at which the first set of traces pass over the second set of traces while separated by the dielectric material of the substrate.

9. A capacitive touch sensor panel, comprising:
 - sense traces formed on a first side of a dielectric substrate;and
 - drive traces formed on a second side of the substrate, the drive traces widened as compared to the sense traces to provide

**SUBJECT TO PROTECTIVE ORDER
CONTAINS HIGHLY CONFIDENTIAL – ATTORNEYS’ EYES ONLY INFORMATION**

shielding for the sense traces;
wherein sensors are formed at locations at which the sense traces cross over the drive traces while separated by the dielectric substrate.

'182 Application at 19; *id.* at 23. Claims 7 and 8 of the '182 Application contained identical limitations as claim 1, but different preambles. The preambles of claims 7 and 8 described "a mobile telephone having a capacitive touch sensor panel" and "a digital audio player having a capacitive touch sensor panel," respectively. Claims 15 and 19 of the '182 Application were method claims containing similar limitations to claims 1 and 9.

2. December 22, 2009 Office Action

504. On December 22, 2009, the PTO rejected all twenty claims of the '182 Application as obvious in a non-final office action.

505. Claims 1, 3, 4, 9, 11, 12, 15, and 17-20 were rejected as obvious based on U.S. Patent 5,942,733 ("Allen") in view of U.S. Patent No. 7,532,205 ("Gillespie").

506. The Allen and Gillespie were each assigned to Synaptics, and list Timothy Allen as an inventor.

507. Allen was filed October 19, 1995 and relates to "[a] capacitive touch pad compris[ing] a substrate material . . . having a plurality of first parallel conductive traces running in a first (X) direction disposed on a first face thereof, and a plurality of second parallel conductive traces running in a second (Y) direction, usually orthogonal to the first direction, disposed on an opposed second face thereof." Allen at Abstract.

508. The Gillespie patent claiming priority to March 26, 2004, discloses, among other, things

a position-sensing transducer comprising a touch-sensitive surface disposed on a substrate, such as a printed circuit board, including a matrix of conductive lines. A first set of conductive lines run in a

SUBJECT TO PROTECTIVE ORDER
CONTAINS HIGHLY CONFIDENTIAL – ATTORNEYS’ EYES ONLY INFORMATION

first direction and is insulated from a second set of conductive lines running in a second direction generally perpendicular to the first direction. An insulating layer is disposed over the first and second sets of conductive lines. The insulating layer is thin enough to promote significant capacitive coupling between a finger placed on its surface and the first and second sets of conductive lines.

Sensing electronics respond to the proximity of a finger, conductive object, or an object of high dielectric constant (i.e., greater than about 5) to translate the capacitance changes of the conductors caused by object proximity into digital information which is processed to derive position and touch pressure information.

Gillespie at 6:16-32.

509. Figure 1 demonstrates the basic capacitive touch-sensing system disclosed in Gillespie. Figure 2C shows the basic two-layer sensor matrix disclosed in Gillespie. The row traces 26 and column traces 30 in Figure 2C are on separate layers, separated by a dielectric. *See* Gillespie at 10:48-55.

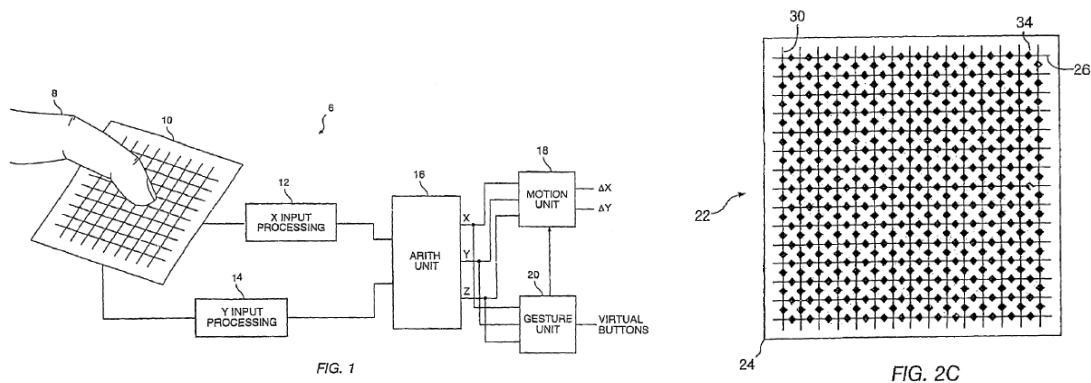

510. Gillespie also teaches the use of driving and sensing electrodes to sense "transcapacitance" (i.e., mutual capacitance) between row and column electrodes on separate layers. *See id.* at 5:36-49; 6:36-65.

1.

The December 22, 2009 Office Action found that Allen taught a

SUBJECT TO PROTECTIVE ORDER
CONTAINS HIGHLY CONFIDENTIAL – ATTORNEYS’ EYES ONLY INFORMATION

capacitive touch sensor panel comprising:: a substrate (12) formed from a dielectric material;

a first set of non-overlapping traces (Y-18) of conductive material located on a first side (20) of the substrate (12) and arranged along a first dimension of a two-dimensional coordinate system; and

a second set of non-overlapping traces (X-14) of the conductive material located on a second side (16) of the substrate (12) and arranged along a second dimension of the two-dimensional coordinate system (col. 3, line 60 to col. 4., line 9).

Dec. 22, 2009 Office Action at 2.

511. The PTO also found that although, "Allen does not specifically teach 'wherein the second set of traces are widened . . . dielectric material of the substrate,'" it would have been obvious to combine Allen with Gillespie, and Gillespie "teaches wherein the second set (X) of traces are widened as compared to the first set (Y) of traces to provide shielding for the first set of traces; and wherein sensors are formed at locations at which the first set of traces pass over the second set of traces while separated by the dielectric material of the substrate (col. 28, lines 52-62)." *Id.* at 2-3. The PTO also found that Gillespie teaches a computing system incorporating a sensor panel. *Id.* at 3(citing Gillespie at col. 1, lines 29-34) of Gillespie.

512. Furthermore the PTO found that "it would have been obvious to one of ordinary skill in the art at the time the invention was made to incorporate the liquid crystal display (LCD) adjacent to the touch sensor panel as taught by Pak in the system of Allen and Gillespie in order to display the information to the user." *Id.* at 3. Thus, the PTO rejected claims 2, 10, and 16 of the '182 Application on this basis.

513. The PTO rejected the remaining claims 5-8, 13, and 14 as obvious based on Allen and Gillespie in view of U.S. Patent Application Publication No. 2003/0231168 ("Bell").

According to the PTO, Allen and Gillespie did not specifically teach a mobile telephone and digital audio player that incorporate the computing system, but it would have been obvious to

**SUBJECT TO PROTECTIVE ORDER
CONTAINS HIGHLY CONFIDENTIAL – ATTORNEYS’ EYES ONLY INFORMATION**

combine Allen and Gillespie with Bell which taught "a mobile telephone and a digital audio player that incorporates the computing system [0042],""in order to allow a convenient communication for users." Dec. 22, 2009 Office Action at 3.

514. The PTO noted that U.S. Patent No. 7,382,139 ("Mackey") and U.S. Patent No. 7,511,702 ("Hotelling '702") were "prior art made of record and not relied upon . . . considered to pertinent [*sic*] applicant's disclosure." *Id.* at 4.

515. Mackey was filed on June 3, 2004 and also assigned o Synaptics. Mackey discloses a capacitive sensing apparatus having varying width sensing elements, as shown in figure 8::

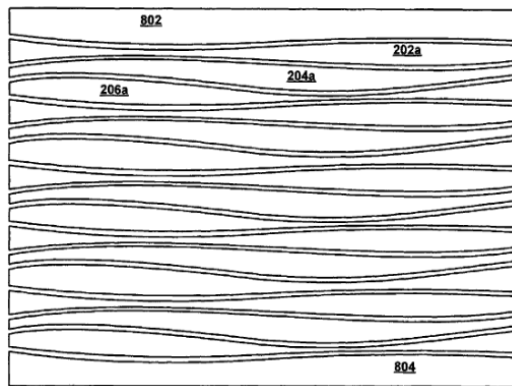

FIG. 8

516. Hotelling '702, was filed seven months before the filing of the '129 Patent, discloses a transparent capacitive touch sensor panel with conductive traces oriented in a first direction and a second direction. This arrangement is illustrated in Fig. 4::

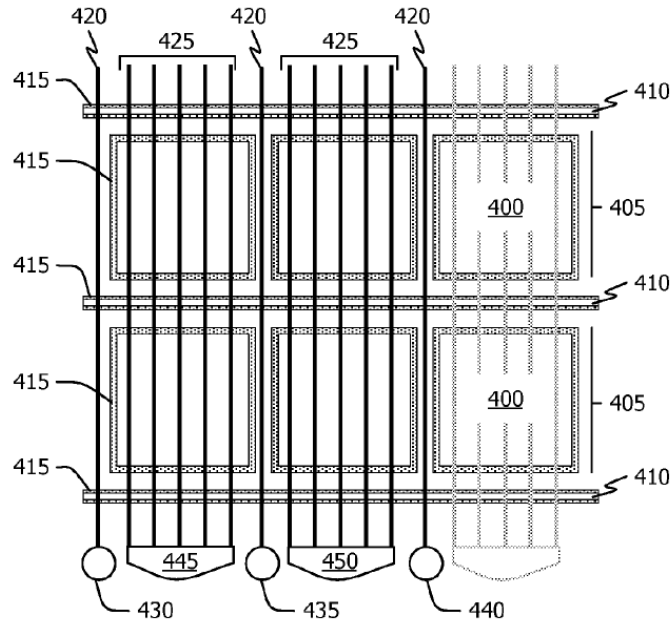

FIG. 4

3. March 5, 2010 Amendments and Remarks

517. The applicants made amendments and remarks in a March 5, 2010 response to the PTO's December 22, 2009 Office Action.

518. The term “non-overlapping traces” was amended to “traces” in claims 1, 7, 8, 15. In claims 9, 11, 15, and 17 "dielectric substrate" were amended to "substrate."

519. The applicants also conducted an in-person interview with the PTO examiner on March 2, 2010 at which they discussed the Allen, Gillespie, Pak, and Bell prior art references. At the meeting, the "the applicant argued that the prior art references did “not specifically teach the claimed limitation 'the second set of traces are widened as compared to the first set of traces.'" '129 Patent File History, Mar. 11, 2010 Summary of Mar. 2, 2010 Interview; see also *id.* at Mar. 5, 2010 Amendments and Remarks.

520. The applicants focused on only the "the second set of traces are widened as compared to the first set of traces" in distinguishing Gillespie, Allen, Pak, and Bell. In fact, this

**SUBJECT TO PROTECTIVE ORDER
CONTAINS HIGHLY CONFIDENTIAL – ATTORNEYS’ EYES ONLY INFORMATION**

limitation was the sole limitation in the twenty pending claims that the applicants argued was not disclosed by the Allen, Gillespie, Pak, and Bell prior art references.

521. The applicants' remarks with respect to claims 1, 3, 4, 9, 11, 12, 15, and 17-20 are shown below:

Claims 1, 3, 4, 9, 11, 12, 15 and 17-20 were rejected under 35 U.S.C. §103(a) as being unpatentable over Allen in view of Gillespie. This rejection is respectfully traversed.

Claim 1 recites, in part (emphasis added):

a first set of traces of conductive material located on a first side of the substrate . . . and a second set of traces of the conductive material located on a second side of the substrate . . . wherein *the second set of traces are widened as compared to the first set of traces* to provide shielding for the first set of traces.

Claim 9 recites, in part (emphasis added):

sense traces formed on a first side of a dielectric; and drive traces formed on a second side of the dielectric, *the drive traces widened as compared to the sense traces* to provide shielding for the sense traces.

Claim 15 recites, in part (emphasis added):

forming a first set of sense traces on a first side of a dielectric . . . [and] forming a second set of widened drive traces on a second side of the dielectric, *the drive traces widened as compared to the sense traces* to provide shielding for the sense traces.

Claim 19 recites, in part (emphasis added):

forming a first set of sense traces on a first side of a dielectric substrate . . . [and] forming a second set of widened traces on a second side of the substrate closest to the source of capacitive coupling to provide shielding for the first set of traces.

'129 Patent File History, Mar. 5, 2010 Amendments and Remarks, at 7-8.

522. The applicants' remarks with respect to claims 2, 10, and 16 are shown below:

Claims 2, 10 and 16 were rejected under 35 U.S.C. §103(a) as being unpatentable over Allen in view of Gillespie and further in view of Pak. This rejection is respectfully traversed.

Claim 2 depends from claim 1, claim 10 depends from claim 9, and claim 16 depends from claim 15. As discussed above, neither Allen nor Gillespie, alone or in combination, discloses, teaches or suggests all of the limitations of claims 1, 9, 15. Furthermore, Pak fails to make up for the deficiencies of Allen and Gillespie, because Pak also fails to disclose, teach or suggest a second set of traces that are wider than a first set of traces to provide shielding for the first set of traces. Pak discloses a liquid crystal display including a sensing unit, but contains no disclosure at all related to a second set of traces that are wider than a first set of traces to provide shielding for the first set of traces.

'129 Patent File History, Mar. 5, 2010 Amendments and Remarks, at 8-9.

523. The applicants' remarks with respect to claims 5 and 6 are shown below:

**SUBJECT TO PROTECTIVE ORDER
CONTAINS HIGHLY CONFIDENTIAL – ATTORNEYS’ EYES ONLY INFORMATION**

Claims 5-8, 13 and 14 were rejected under 35 U.S.C. §103(a) as being unpatentable over Allen in view of Gillespie and further in view of Bell. This rejection is respectfully traversed.

Claims 5 and 6 depend from claim 1. As discussed above, neither Allen nor Gillespie, alone or in combination, discloses, teaches or suggests all of the limitations of claim 1. Furthermore, Bell fails to make up for the deficiencies of Allen and Gillespie, because Bell also fails to disclose, teach or suggest a second set of traces that are wider than a first set of traces to provide shielding for the first set of traces. Bell discloses a processing module and a touch screen, but contains no disclosure at all related to a second set of traces that are wider than a first set of traces to provide shielding for the first set of traces.

'129 Patent File History, Mar. 5, 2010 Amendments and Remarks, at 9.

524. The applicants' remarks with respect to claims 7 and 8 are shown below:

Claims 1, 7 and 8 recite, in part (emphasis added):

a first set of traces of conductive material located on a first side of the substrate . . . and a second set of traces of the conductive material located on a second side of the substrate . . . wherein *the second set of traces are widened as compared to the first set of traces* to provide shielding for the first set of traces.

For the same reasons discussed above with respect to claim 1, neither Allen nor Gillespie, alone or in combination, discloses, teaches or suggests all of the limitations of claims 7 and 8. Furthermore, Bell fails to make up for the deficiencies of Allen and Gillespie for the reasons discussed above with regard to claims 5 and 6.

'129 Patent File History, Mar. 5, 2010 Amendments and Remarks, at 9-10.

525. The applicants' remarks with respect to claims 13 and 14 are shown below:

Claims 13 and 14 depend from claim 9. As discussed above, neither Allen nor Gillespie, alone or in combination, discloses, teaches or suggests all of the limitations of claim 9. Furthermore, Bell fails to make up for the deficiencies of Allen and Gillespie for the reasons discussed above with regard to claims 5 and 6.

'129 Patent File History, Mar. 5, 2010 Amendments and Remarks, at 7-8.

526. These remarks confirm that the "second set of traces are widened as compared to the first set of traces" was only limitation in any of the twenty pending claims that the applicants argued was not disclosed by Allen, Gillespie, Allen, and Pak.

4. May 26, 2010 Office Action

527. The PTO again rejected all twenty pending claims of the '182 Application as obvious in a non-final office action dated May 26, 2010.

**SUBJECT TO PROTECTIVE ORDER
CONTAINS HIGHLY CONFIDENTIAL – ATTORNEYS’ EYES ONLY INFORMATION**

528. The PTO found that claims 1-4, 9-12, and 15-20 obvious based on Allen in view of U.S. Patent No. 5,869,791 ("Young").

529. Young was filed March 1, 1996 and assigned to U.S. Philips Corporation. The Young patent teaches, among other things, "[a] touch sensing device comprising a plurality of individually operable touch sensing elements having first and second overlapping and spaced conductive layers (12, 15) . . . fabricated by forming on a support a thin film multi-layer structure comprising the first and second conductive layers with an insulating layer (16) therebetween." Young at Abstract. According to Young, "[t]he device may be used, for example, as a keypad or, with larger numbers of elements arranged in a row and column matrix, as a graphics tablet or display overlay," and "[t]he device can conveniently be integrated with a liquid crystal display panel using a substrate of the panel as the support." *Id.* Figure 4 of Young illustrates one such touch-sensing device:

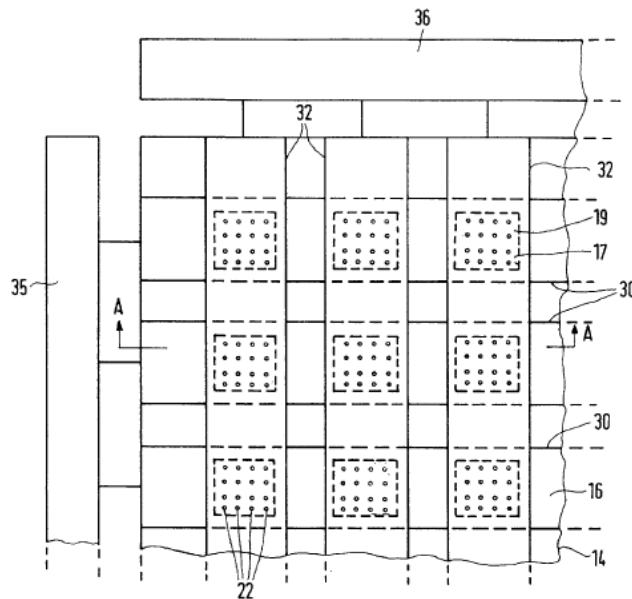

FIG. 4

SUBJECT TO PROTECTIVE ORDER
CONTAINS HIGHLY CONFIDENTIAL – ATTORNEYS’ EYES ONLY INFORMATION

530. Regarding Figure 4 Young teaches that, "[t]he strips constituting the row and column conductors 30 and 32 need not be of constant width. Their width in the regions between adjacent sensing elements may be reduced." *Id.* at 10:26-28.

531. The PTO found that Allen teaches a capacitive touch sensor panel comprising:

- a substrate (12) formed from a dielectric material;
- a first traces (Y-18) of conductive material located on a first side (20) of the substrate (12) arranged along a first dimension of a two-dimensional coordinate system; and
- a second set of traces (X-14) of the conductive material located on a second side (16) of the substrate (12) and arranged along a second dimension of the two-dimensional coordinate system; and wherein sensors are formed at locations at which the first set of traces pass over the second set of traces while separated by the dielectric material of the substrate (col. 3, line 60 to col. 4, line 9).

'129 Patent File History, May 26, 2010 Office Action, at 2.

532. The PTO found that, "Young teaches wherein the second set (30) of traces are widened as compared to the first set (32) of traces to provide shielding for the first set of traces (col. 9, line 58 to col. 10, line 28)," and "it would have been obvious to one of ordinary skill in the art at the time the invention was made to incorporate the traces as taught by Young in the system of Allen in order to provide a uniform appearance." *Id.* at 2-3.

533. Furthermore, the PTO found that "the combination of Allen and Young teaches a liquid crystal display (LCD) adjacent to the touch sensor panel (col. 3, lines 49-65 of Young)," and "the LCD emitting a modulated Vcom signal is inherent in the LCD; therefore, the combination of Allen and Young obviously teaches the widened second set of traces configured for shielding the first set of traces from the modulated Vcom signal." Furthermore, Young also "teaches . . . a computing system that incorporates the sensor panel (col. 1, lines 35-30 [*sic*] of Young)." *Id.*

**SUBJECT TO PROTECTIVE ORDER
CONTAINS HIGHLY CONFIDENTIAL – ATTORNEYS’ EYES ONLY INFORMATION**

534. The PTO held that claims 5-8, 13, and 14 were obvious based on Allen and Young in view of Bell, because "Bell teaches a mobile telephone and digital audio player that incorporates the computing system [0042]." The PTO also explained that it would have been obvious to combine bell with Allen and Young "in order to allow a convenient communication for users." *Id.* at 3-4.

535. In view of the new grounds for objections, the PTO found that the applicant’s previous arguments had been mooted. *Id.* at 4.

5. July 30, 2010 Amendments and Remarks

536. The responded to the PTO's May 26, 2010 Office Action in a communication to the PTO dated July 30, 2010.

537. The applicants made only amendment in response to the May 26, 2010 Office Action . The amendment was non-substantive and corrected a dependency error. *See* '129 Patent File History, Jul. 30, 2010 Amendments and Remarks, at 6-7.

538. The applicants' July 30, 2010 Amendments and Remarks focused on *only* a single claim limitation to distinguish Allen, Young, and Bell, "the second set of traces are widened as compared to the first set of traces." *Id.* at 7-10.

539. The applicants' July 30, 2010 Amendments and Remarks did not contest that Allen, Young, and Bell disclose: drive and sense traces on separate layers that sensed mutual capacitance, an LCD emitting a modulated Vcom signal, drive traces configured for being driven by low-impedance outputs, a computing system, digital audio player, and mobile telephone incorporating a capacitive touch panel, or any other limitation present in the twenty amended claims of the '182 Application other than "the second set of traces are widened as compared to the first set of traces." *Id.*

**SUBJECT TO PROTECTIVE ORDER
CONTAINS HIGHLY CONFIDENTIAL – ATTORNEYS’ EYES ONLY INFORMATION**

540. The applicants admitted that Young discloses that the column conductors on the top layer of conductors could have a narrower width than the bottom row, but argued that these traces would only be wider "in the regions between adjacent sensing elements." *Id.* at 8-9

6. October 15, 2010 Office Action

541. The PTO again rejected all twenty pending claims of the '182 Application as obvious in an October 15, 2010 non-final office action.

542. The PTO found that claims 1-4, 9-12, and 15-20 were obvious in light of on Allen and Young in view of Gillespie.⁶ According to the PTO, Allen and Young disclosed all of the structural limitations of these claims,, but did not explain the benefit of shielding. '129 Patent File History, October 15, 2010 Office Action, at 2-3. However, according to the PTO, Gillespie taught that one set of lines could be used to shield the second set of lines.

543. The PTO found that claims 5-8, 13, and 14 were obvious based on Allen, Young, Gillespie, and Bell. *Id.* at 4-5.

544. According to the PTO, "Young teaches the width of the column conductors may be reduced in regions but the set of traces are still widened as compared to the other set of traces in some reasons so that still [*sic*] read on the claims." *Id.*

545. The PTO stated that "it had fully considered the applicants' 7/30/2010 arguments, but did not find them persuasive. *Id.* at 5.

7. October 28, 2010 Interview

546. The applicants proposed amendments to the claims in response to the October 15, 2010 Office Action, and conducted an in-person interview with the PTO examiner on October

⁶ The PTO cited a different Gillespie publication, U.S. Patent Application No. 2006/0092142 ("Gillespie '142") than the Gillespie '205 patent the PTO had cited earlier in prosecution, but the disclosure of these two references, each of which is a continuation of the same patent application filed March 26, 2004, is identical.

**SUBJECT TO PROTECTIVE ORDER
CONTAINS HIGHLY CONFIDENTIAL – ATTORNEYS’ EYES ONLY INFORMATION**

28, 2010. During the interview, the parties discussed the alleged differences between the amended claims and the Allen, Young, Gillespie, and Bell prior art references. *Id.* at Nov. 3, 2010 Summary of Oct. 28, 2010 Interview.

8. **November 8, 2010 Amendments and Remarks**

547. The applicants made further amendments and remarks in response to the PTO's October 15, 2010 Office Action on October 28, 2010.

548. The applicants made substantive, limiting amendments to claims 1-3, 7-11, 15, 17, and 19-20, and added new claims 21-33. Claims 1-17 of the '182 Application correspond to claims 1-17 of the '129 Patent. Claims 19-21 of the '182 Application correspond to claims 18-20 of the '129 Patent. Claims 23 and 25 of the '182 Application correspond, respectively, to claims 21 and 22 of the '129 Patent. Claims 27-33 of the '182 Application correspond to claims 23-29 of the '129 Patent. *See* '129 Patent File History, Nov. 8, 2010 Amendments and Remarks, at 2-10. The amendments to claim 1 are representative of the amendments to claims 7 and 8. The amendments to claim 3 are representative of the amendments to claims 11, 17, and 20. The amendments to claim 9 are representative of the amendments to claims 15 and 19. The amendments to claims 1, 3, and 9 are shown below:

SUBJECT TO PROTECTIVE ORDER
CONTAINS HIGHLY CONFIDENTIAL – ATTORNEYS’ EYES ONLY INFORMATION

Claim 1 (currently amended): A capacitive touch sensor panel, comprising:

~~a substrate formed from a dielectric material;~~

a first set of traces of conductive material ~~located on a first side of the substrate and~~ arranged along a first dimension of a two-dimensional coordinate system, the first set of traces having one or more widths and a maximum width; and

a second set of traces of the conductive material ~~located on a second side of the substrate~~ spatially separated from the first set of traces by a dielectric and arranged along a second dimension of the two-dimensional coordinate system, the second set of traces having one or more widths and a minimum width;

wherein the minimum width of the second set of traces are widened as compared to is substantially greater than the maximum width of the first set of traces at least at each intersection of the first and second sets of traces to provide shielding for the first set of traces; and

wherein sensors are formed at locations at which the first set of traces ~~pass over~~ intersect with the second set of traces while separated by the ~~dielectric material of the substrate.~~

Claim 3 (currently amended): The capacitive touch sensor panel of claim 1, wherein the second set of traces are widened to substantially ~~cover the second side of the substrate except for a gap of about 30 microns between adjacent traces~~ electrically isolate the first set of traces from a liquid crystal display (LCD).

Claim 9 (currently amended): A capacitive touch sensor panel, comprising:

sense traces ~~formed on a first side of a dielectric~~ having one or more widths and a maximum width; and

drive traces ~~formed on a second side of the dielectric~~ spatially separated from the sense traces by a dielectric, the drive traces having one or more widths and a minimum width, the minimum width of the drive traces widened as compared to being substantially greater than the maximum width of the sense traces at least at each intersection of the sense and drive traces to provide shielding for the sense traces;

wherein sensors are formed at locations at which the sense traces ~~cross over~~ intersect with the drive traces while separated by the dielectric.

Id. at 2-4.

549. The applicants sought to distinguish the amended claims from Allen, Young, Gillespie, and Bell. Again, the applicants' November 8, 2010 Amendments and Remarks focused on *only* the "a minimum width of a second set of (or drive) traces is substantially greater than a maximum width of a first set of (or sense) traces, at least at each intersection of the first and second sets of (or drive and sense) traces" Limitation. *Id.* at 12.

**SUBJECT TO PROTECTIVE ORDER
CONTAINS HIGHLY CONFIDENTIAL – ATTORNEYS’ EYES ONLY INFORMATION**

550. The applicants' remarks indicated that the limiting amendments to the claims were made specifically to overcome the Young reference. *Id.* at 12-13.

9. January 14, 2011 Office Action

551. The PTO rejected new claims 21, 23, 25, and 27-29, but allowed claims 1-17, 19, and 20 and new claims 30-33 in a final office action dated January 14, 2011.

552. Claims 21, 23, and 25 were rejected as obvious based on Allen and Young. The PTO explained:

Regarding claims 21, 23, and 25, Allen teaches a capacitive touch sensor (10), comprising:

sense traces (Y-18) formed on a first layer and arranged along a first dimension of a two-dimensional coordinate system; and

drive traces (X-14) formed on a second layer spatially separated from the first layer by a dielectric, the drive traces arranged along a second dimension of the two-dimensional coordinate system; and

wherein sensors are formed at locations at which the sense lines intersect with the drive traces while separated by the dielectric (col. 3, line 60 to col. 4, line 9).

'129 Patent File History, Jan. 14, 2011 Office Action, at 2-3.

553. The PTO also explained that:

Young teaches wherein the second set of traces (30) is widened as compared to the first set of traces (32) (regions between adjacent sensing elements maybe reduced) to substantially cover the second layer except for a gap between adjacent drive traces so as to substantially electrically isolate the sense traces from a liquid crystal display (col. 9, line 58 to col. 10, line 28, lines 41-45). Therefore, it would have been obvious to one of ordinary skill in the art at the time the invention was made to incorporate the traces as taught by Young in the system of Allen in order to reduce the weight and density of the touch panel.

Id. at 3.

**SUBJECT TO PROTECTIVE ORDER
CONTAINS HIGHLY CONFIDENTIAL – ATTORNEYS’ EYES ONLY INFORMATION**

554. The PTO also rejected claims 27-29 as obvious based on Allen and Young in view of Bell.

10. February 4, 2011 Amendments and Remarks

555. The applicants responded to the PTO's January 14, 2011 Office Action by making amendments and remarks to the PTO in a communication dated February 4, 2011.

556. The applicants amended claims 1, 7-9, 15, 19, 21, 23, and 25.

557. The amendments to claim 1 are representative of the amendments to claims 1, 7-9, 15, and 19. These amendments are shown below:

Claim 1 (currently amended): A capacitive touch sensor panel, comprising:
a first set of traces of conductive material arranged along a first dimension of a two-dimensional coordinate system, the first set of traces having one or more widths ~~and~~including a maximum width; and
a second set of traces of the conductive material spatially separated from the first set of traces by a dielectric and arranged along a second dimension of the two-dimensional coordinate system, the second set of traces having one or more widths ~~and~~including a minimum width;
wherein the minimum width of the second set of traces is substantially greater than the maximum width of the first set of traces at least at ~~each~~an intersection of the first and second sets of traces to provide shielding for the first set of traces; and
wherein sensors are formed at locations at which the first set of traces intersects with the second set of traces while separated by the dielectric.

'129 Patent File History, Feb. 4, 2011 Amendments and Remarks, at 2.

558. The amendments to claim 21 are representative to the amendments to claims 21, 23, and 25, and are shown below:

Claim 21 (currently amended): A capacitive touch sensor panel, comprising:
sense traces formed on a first layer and arranged along a first dimension of a two-dimensional coordinate system; and
drive traces formed on a second layer spatially separated from the first layer by a dielectric, the drive traces arranged along a second dimension of the two-dimensional coordinate system;
wherein the drive traces are widened as compared to the sense traces to substantially cover the second layer except for a gap between adjacent drive traces so as to substantially electrically isolate the sense traces from a liquid crystal display (LCD); ~~and~~
wherein sensors are formed at locations at which the sense traces intersect with the drive traces while separated by the dielectric; ~~and~~
wherein each of the drive traces is of a substantially constant width.

**SUBJECT TO PROTECTIVE ORDER
CONTAINS HIGHLY CONFIDENTIAL – ATTORNEYS’ EYES ONLY INFORMATION**

Id. at 7.

559. The amendments to claims 21, 23, and 25 sought to overcome the obviousness in view of Allen and Young. The applicants explained that, "[c]laims 21, 23 and 25 have been amended to include the limitations of claims, 22, 24 and 26, respectively, which is similar to rewriting claims 22, 24, and 26 into independent form including all of the limitations of the base claim and any intervening claims, a form indicated to be allowable as mentioned above.”

560. The applicants characterized the purpose of the amendments to claims 1, 7-9, as being for clarity." *Id.* at 11.

11. February 14, 2011 Notice of Allowance

561. On February 14, 2011, the PTO mailed a notice of allowance stating that allowing claims 1-17, 19-21, 23, 25, and 27-33.

562. The PTO provided no written explanation regarding the allowability of these claims.

D. Priority Date

563. It is my opinion that Apple has not shown a date of conception or reduction to practice of the asserted claims between April and May of 2005, the date it asserts is the proper priority date. It is my understanding that Apple has identified numerous documents in its Fifth Amended Objections and Responses to Samsung’s Interrogatory No. 1, including APLNDC-X0000002077-2158; APLNDC0000175860-69; APLNDC00014679-82; APLNDC-X0000002077-2158; APLNDC0000175860-69; APLNDC00014679-82; APLNDC-X0000002077-2158; APLNDC0000175860-69; APLNDC00014679-82; APLNDC0000101097-142; APLNDC0000152663-69; and APLNDC0000153871-72 as evidence concerning conception and/or reduction to practice of the asserted claims of the '129 patent. I have reviewed

**SUBJECT TO PROTECTIVE ORDER
CONTAINS HIGHLY CONFIDENTIAL – ATTORNEYS’ EYES ONLY INFORMATION**

each of these documents and the date, if any, that each document was created. I have compared them to the asserted claims. It is my opinion that the documents predating January 3, 2007 that Apple has identified do not individually or in combination disclose each and every element of any asserted claim of the '129 patent. As such, it is my opinion that these documents do not indicate that Apple was in possession of the claimed invention of the asserted claims of the '129 patent prior to January 3, 2007.

564. [REDACTED]

- | [REDACTED]
- | [REDACTED]
- | [REDACTED]
- | [REDACTED]

565. [REDACTED]

[REDACTED]

[REDACTED]

E. Claim Construction

566. I understand that there are no disputed claim terms from the asserted claims of the '129 patent. I understand that the terms are entitled to their plain and ordinary meaning. I also understand that even though "substantially electrically isolate" was not a term for construction, it can still be indefinite.

XV. SCOPE OF THE PRIOR ART

567. All of the limitations of the asserted claims were well known at least one year prior to the filing date of the application for the '129 patent, as is apparent from the attached invalidity claim charts that explains in detail my opinions regarding why each Asserted Claims is anticipated or rendered obvious by the prior art.

568. As was mentioned above, the '129 patent is nothing more than a slight design modification to the design disclosed in the '607 patent. Virtually everything claimed in the '129 patent was described in the WIPO Publication of the PCT counterpart to the '607 patent, WIPO Publication No. WO 2005/114369 ("Hotelling '369"), which was published on December 1, 2005, more than a year before the '129 patent was filed.⁷ I have reviewed both the '607 patent application and Hotelling '369 and they appear to be identical disclosures. The only claimed features in the '129 patent that are not explicitly disclosed in the Hotelling '369 publication are

⁷ I understand that because all of the prior art that I have identified and charted in Exhibits 129-1 through 129-5, including Hotelling '369, was either on sale or in public use in the United States, or patented or described in a printed publication more than a year before the '129 patent was filed, Apple cannot swear behind any of those references. I also understand that even though Hotelling '369 was assigned to Apple at the time its parent application was filed, it can still be used to render the '129 patent obvious.

**SUBJECT TO PROTECTIVE ORDER
CONTAINS HIGHLY CONFIDENTIAL – ATTORNEYS’ EYES ONLY INFORMATION**

(1) shielding sense traces and (2) drive traces on the bottom and sense traces on top.⁸ But both of those are well documented features known long before the '129 patent was filed. Hotelling '369 also does not mention low impedance driver output and modulated Vcom signal, but those very minor limitations present in dependent claims and 1 independent claim were well known long before the '129 was filed.

569. More specifically, the '129 patent claims these general features all known in the prior art more than a year before Apple ever filed the '129 application:

All claims:

- Capacitive touch sensor panel with conductive traces on two layers separated by a dielectric
- Traces on one layer are widened at least at an intersection between the two sets of traces.
- Widening of one set of traces provides shielding for the other set of traces

Some Claims

- The widened traces are the "drive" traces and the other traces are the "sense traces"
- Sensing based on mutual capacitance
- The touch sensor panel included an LCD display
- An LCD display with a modulated Vcom signal
- Low impedance driver output
- Substantially constant width drive traces

⁸ Although Hotelling '369 does explicitly state that drive traces are on the bottom, it does state, as outlined in Exhibit 129-5, that "[i]n **most** cases, the top layer provides the driving lines." One of ordinary skill in the art would understand that this disclosure necessarily discloses that in some cases the drive traces could be on the bottom. See Exhibit 129-5 at **[1B]-[1D]**.

**SUBJECT TO PROTECTIVE ORDER
CONTAINS HIGHLY CONFIDENTIAL – ATTORNEYS' EYES ONLY INFORMATION**

570. Hotelling '369 alone discloses or renders obvious every feature above. And as mentioned above in the '607 section, as well as in the Supplemental Invalidity Opinions of the '607 Patent, the '607 patent has been found invalid, which indicates that the '129 adds nothing novel over the prior art.

B. General Summary of the Prior Art

1. Apple's Own/Admitted Prior Art

(a) Hotelling '369 (the '607 patent)⁹

571. The '129 patent has a common inventor with the '607 patent – Steve Hotelling. The '129 patent was filed almost two years after Apple claims the inventors came up with the '129 invention. It is my opinion that the '129 patent discloses nothing more than a minor and obvious modification to the general design described in the '607 patent. The only changes were switching the drive and sense lines such that drive was on bottom and sense was on top and noticing a shielding effect that apparently reduced the signal to noise ratio of the system by doing so. This is not an inventive feature. Using drive lines closer to a source of noise, such as an LCD display, was known long before the '129 invention and using substantially wider lower traces was also known. See, e.g., Depositions of Samuel Brunet and Richard Woolley and exhibits thereto. It is my opinion that for at least the reason that the '607 is invalid and has already been found invalid by an ALJ in the 750 Investigation, the '129 must necessarily also be invalid.

(b) Admitted Prior Art

572. The '129 patent lays out the technology landscape existing at the time before Apple filed the '129 patent application. They do this in the "Background of the Invention"

⁹ I understand that the claims of the '607 patent are different than the claims in the Hotelling '369 publication, but the specifications are substantially identical.

SUBJECT TO PROTECTIVE ORDER
CONTAINS HIGHLY CONFIDENTIAL – ATTORNEYS' EYES ONLY INFORMATION

section. In this section, Apple admits the following features were known prior art to the '129 patent:

- A clear touchscreen positioned in front of a display screen
- Capacitive touchscreens in which rows and columns are formed on opposite sides of a dielectric
- "conventional touch panels for use over display devices have typically utilized a top layer of glass upon which transparent column traces of indium tin oxide (ITO) ... have been etched, and a bottom layer of glass upon which row traces of ITO have been etched."
- Recognizing touch pad technology: "in addition, if panel transparency is not required (e.g., the touch panel is not being used over a display device), the conductors can be made out of an opaque material"
- Sensor panels where a row is stimulated and a modulate output signal can be capacitively coupled onto the columns of the sensor panel
- Sensors "located at the intersection of simulated row and connected column"
- In cases where a transparent capacitive touch sensor panel is bonded to a liquid crystal display (LCD), a modulated Vcom layer in the LCD can couple onto the columns of the sensor panel causing noise to appear on the columns.

See id. at 1:14-2:40.

573. The '129 patent basically discloses every limitation in the above mentioned "Background" section. This is consistent with the file history where the applicants never indicated that any limitation of any asserted claim was not present in the prior art *except* "the second set of traces are widened as compared to the first set of traces." Apple even had to amend that limitation before it was allowed.

574. After reviewing the intrinsic record, including the '129 patent, its file history, and the inventors' deposition transcripts, I think that one of ordinary skill in the art would understand that the applicants thought the only novel aspect of the '129 patent was the limitation "minimum width of the drive traces being substantially greater than the maximum width of the sense traces

**SUBJECT TO PROTECTIVE ORDER
CONTAINS HIGHLY CONFIDENTIAL – ATTORNEYS’ EYES ONLY INFORMATION**

at least at an intersection of the sense and drive traces." See, e.g., '129 file history, '129 patents, and the deposition testimony of Brian Land and Steve Hotelling.

575. Most significantly, the only purported "new" limitations – those involving widening the lower traces to provide shielding -- were well-known in the art as my attached invalidity charts (Exhibits 129-1 through 129 -5) document in great detail.

C. Overview of Exemplary Prior Art to the '129 Patent

576. As discussed previously, mutual capacitance touchscreens were disclosed as early as the 1960's. In the 1970's, self capacitance touchscreens were also disclosed. The 1980's brought the discovery of mutual capacitance with row and column electrodes, structures that permit unambiguous scanning of multiple touches on a touch panel. The 1990's saw the widening of lower traces that provided greater shielding from noise sources, as shown in Gerpheide '658. In the early 2000's, transparent touchscreens came into common practice, such as the Nintendo DS in 2004. At the same time, capacitive touchscreens came into common use as the market need for such touchscreens widened before the filing of the '129 patent.

1. GlidePoint (Exhibit 129-1)

577. The GlidePoint product sold by Cirque Corporation starting in the 1990's utilized mutual capacitance to detect proximity and touches on its surface. The wide horizontal drive traces shown in the figure below provided shielding for the narrow green traces hiding behind the red traces. In this view, the aggressor noise signals would be above the red signals, while the protected sensing signals are protected behind the red driving shield traces. Because the red electrodes are driven by low-impedance traces, the shielding of this structure can be very effective, since the complex impedance to ground is minimized by low-impedance drivers.

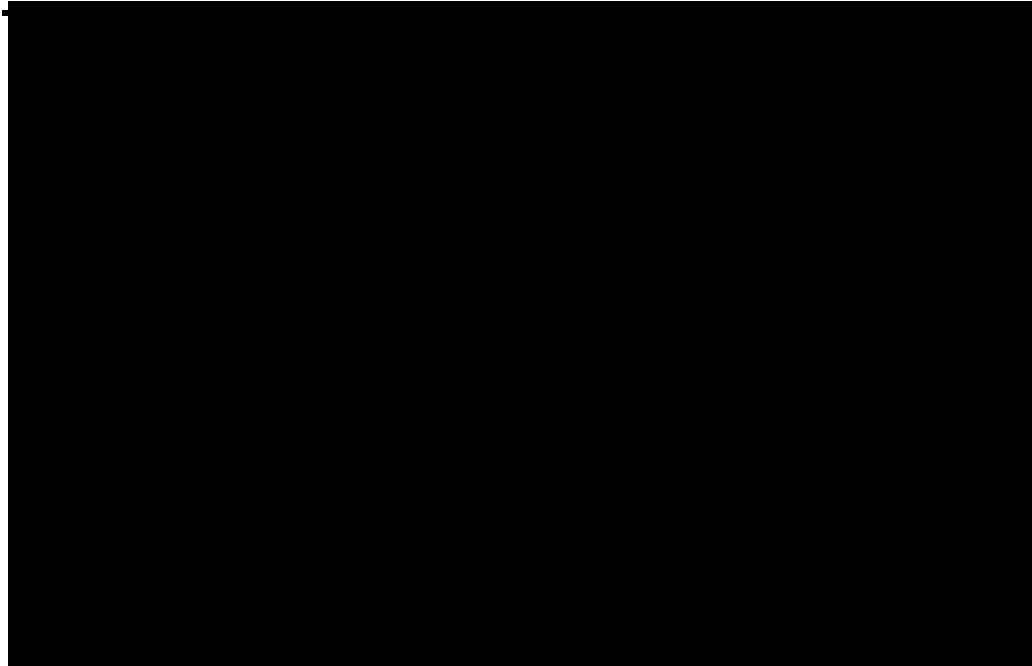

578. The GlidePoint product renders obvious all the asserted claims of the ‘129 patent, and directly anticipates many of these claims. [REDACTED]

[REDACTED] I have attached Exhibit 129-1 describing the anticipation and obviousness of the ‘129 in light of the GlidePoint product.

2. Gerpheide '658 (Exhibit 129-2)

579. The Gerpheide ‘658 patent discloses a two-layer mutual capacitance apparatus that rejects electromagnetic interference (noise). The wide lower electrodes were the drivers while the upper electrodes did the sensing. This is the same configuration for minimizing the noise associated with an LCD display. Below is a drawing of the approximate sizes of the row and column electrodes:

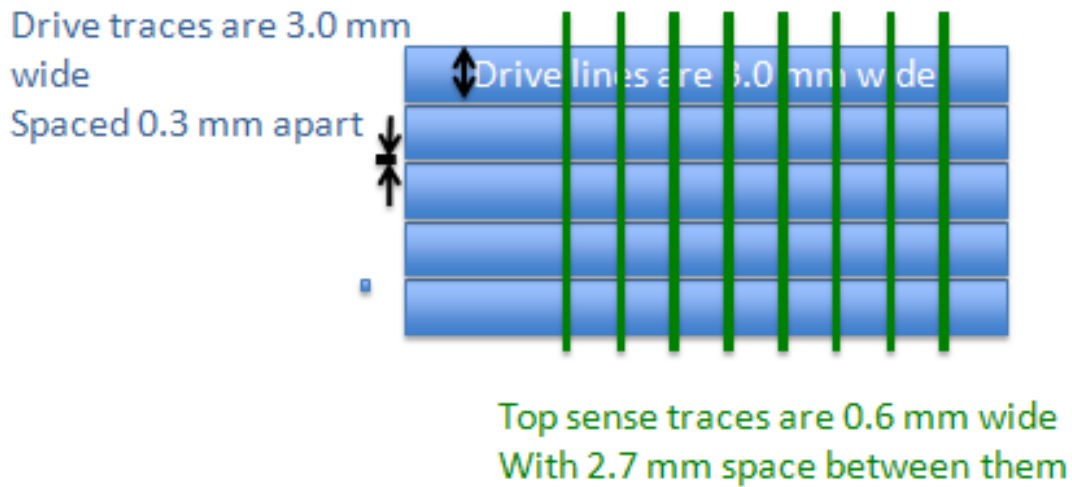

580. As is clear from the above drawing approximately to scale, the blue row drive conductive traces blocked much of the green signals from electromagnetic interference from the underlying substrate. A key objective of this patent was the rejection of noise. In my opinion, all of the claims of the '129 patent are rendered obvious by Gerpheide '658. Many of the '129 claims are directly anticipated by Gerpheide '658. I have attached Exhibit 129-2 describing the anticipation and obviousness of the '129 in light of Gerpheide '658.

3. Velos (Exhibit 129-3)

581. The Velos system provided an interface for a microwave oven. It was available in 2005 and was based on mutual capacitance of the vertical and horizontal traces. [REDACTED]

[REDACTED]

[REDACTED]

[REDACTED]

[REDACTED]

[REDACTED] I believe the Velos prior

art renders all of the asserted claims of the '129 patent obvious, with many of the '129 claims

directly anticipated by the Velos prior art. I have attached Exhibit 129-3 describing the anticipation and obviousness of the ‘129 in light of Velos.

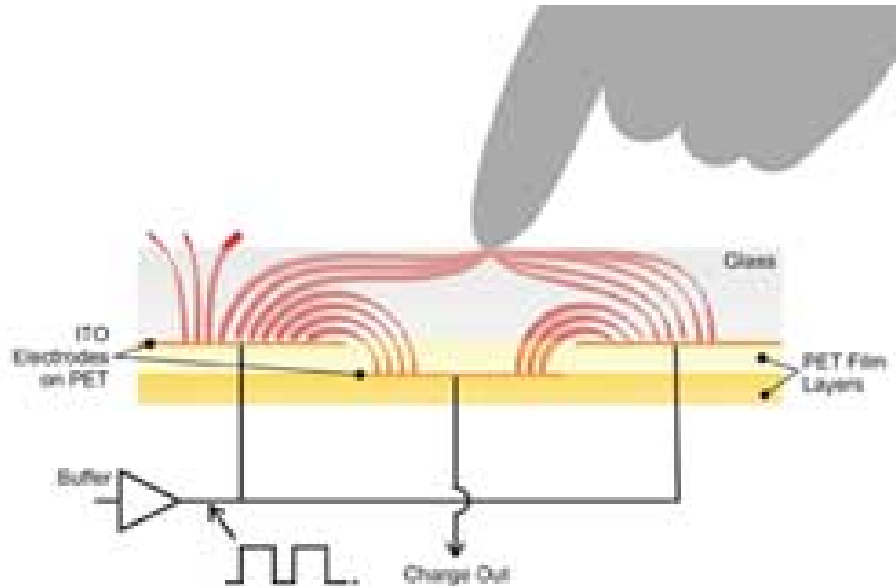

4. Philipp '898 (Exhibit 129-4)

582. The Philipp ‘898 patent was assigned to Atmel, describing a touch sensitive screen based on mutual capacitance. It has wide lower drive electrodes and narrow upper sense electrodes. The invention recommended placing the narrow sense electrodes near the side of the objects being sensed. This invention described using this device in a portable player or cellular telephone. The electrodes could be made of ITO (indium tin oxide) with a non-conductive polymer layer in between. The mutual capacitance provided by a finger, for example, established the vertical and horizontal location of the touch sensing.

583. The figure below shows the wide column drive traces that provide shielding for the narrower sense traces shown in the figure labeled 1B below. Those narrower traces provided the narrow row sensing electrodes.

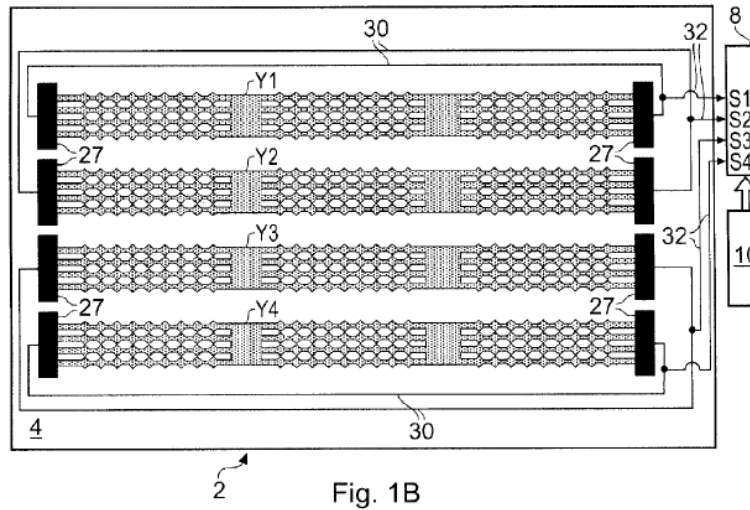
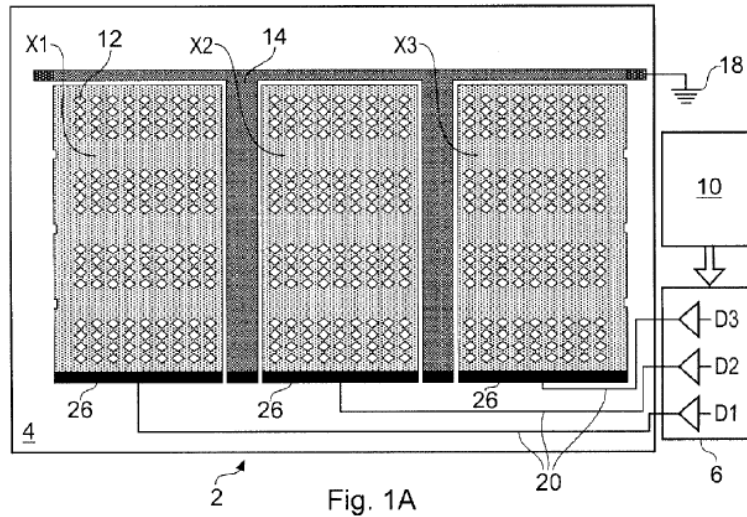

584. I believe the Philipp ‘898 prior art renders all of the asserted claims of the ‘129 patent obvious, with many of the ‘129 claims directly anticipated by the Philipp ‘898 prior art. I have attached Exhibit 129-4 describing the anticipation and obviousness of the ‘129 in light of Philipp ‘898.

5. Hotelling '369 (Exhibit 129-5)

585. Hotelling ‘369 discloses a multi-touch screen. It was published December 1, 2005, more than a year before the ‘129 patent was filed. This disclosure described a mutual capacitance touchscreen with wide electrodes in one direction and narrower electrodes in the perpendicular direction.

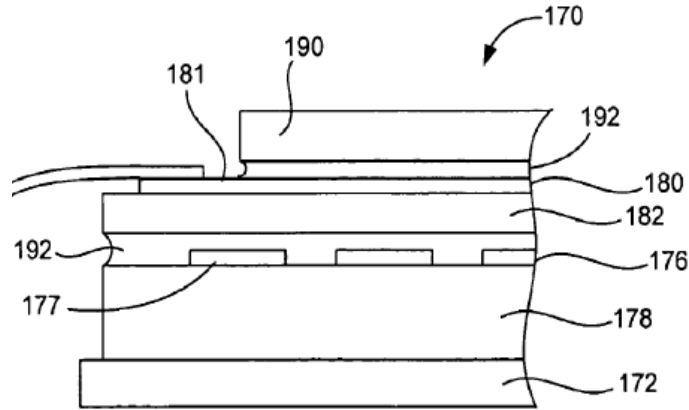
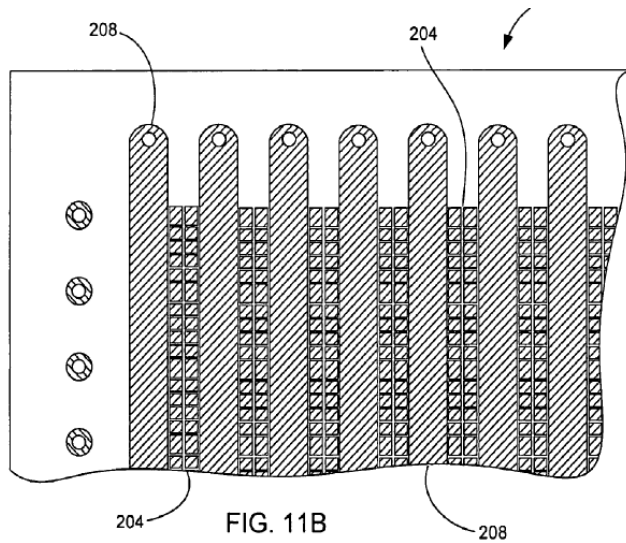

FIG. 10

586. The stackup comprised two perpendicular rows and columns of electrodes with a dielectric in between.



587. The column electrodes were wide, while the row electrodes were narrower (not shown). Hotelling '369 discloses shielding, with wide drive traces and narrower sensing traces. This disclosure also described mobile phone and mobile player applications. I believe the Hotelling '369 prior art renders all of the asserted claims of the '129 patent obvious, with many of the '129 claims directly anticipated by the Hotelling '369 prior art. I have attached Exhibit 129-5 describing the anticipation and obviousness of the '129 in light of Hotelling '369.

XVI. INVALIDITY OF THE '129 PATENT

A. Anticipation

588. As mentioned above and in detail in the attached Exhibits 129-1 through 129-5, it is my opinion that the Asserted Claims are anticipated by one or more of the GlidePoint, Gerpheide '658, Velos, Philipp '898, and Hotelling '369 prior art references and systems.

589. Below I provide a short summary of my opinions. My detailed limitation-by-limitation opinions regarding why each element of each asserted claim is anticipated and/or rendered obvious by the prior art can be found in my attached invalidity charts at Exhibits 129-1 through 129-5, which are incorporated herein by reference.

1. Cirque GlidePoint System (Exhibit 129-1)

590. In my opinion, the Cirque GlidePoint system used in public, sold, and offered for sale in the United States no later than 1999 embodied each and every limitation of claims 1, 3, 5, 10, 12, 14, 17, and 19, 21-22, 24-25 regardless of whether the respective preambles of these claims are held to be limiting, and therefore anticipates these claims. In my opinion, the Cirque GlidePoint system also embodied each and every limitation of claim 9 to the extent the preambles of that claim is not held to be limiting.¹⁰

591. As I discussed above, I have been informed that to anticipate, a prior art reference must contain an enabling disclosure that allows one of ordinary skill to practice the claims without undue experimentation.

592. I have reviewed the Cirque GlidePoint system from this perspective, including the documentation produced by Cirque and the deposition testimony of Richard Woolley.

¹⁰ In my opinion, a person of ordinary skill in the art would not understand the preamble of claim 9 to breathe life into the claim, and note that the "digital audio player" portion of claim 9's preamble bears no relation whatsoever to any of the limitations in the body of the claim, which is otherwise identical to claim 1.

**SUBJECT TO PROTECTIVE ORDER
CONTAINS HIGHLY CONFIDENTIAL – ATTORNEYS' EYES ONLY INFORMATION**

593. In my opinion, the Cirque GlidePoint system discloses to one of ordinary skill in the art how to practice or carry out the claims I identified above in sufficient detail, without requiring undue experimentation. The disclosures of the Cirque GlidePoint system, as publicly disclosed, used in public, sold, and/or offered for sale in the United States, are greater than or equal to the disclosures in the '129 Patent itself.

594. Exhibit 129-1 provides a limitation-by-limitation analysis of the Cirque GlidePoint system and is incorporated by reference into this report.

2. Gerpheide '658 (Exhibit 129-2)

595. In my opinion, the Gerpheide '658 patent, a United States patent filed December 7, 1994 and issued on October 15, 1996, discloses and enables each and every limitation of claims 1, 3, 5, 10, 12, 14, 17, and 19, 21-22, 24-26 regardless of whether the respective preambles of these claims are held to be limiting, and therefore anticipates these claims. In my opinion, Gerpheide '658 also discloses and enables each and every limitation of claim 9 to the extent the preamble of that claim is not held to be limiting.¹¹

596. As I discussed above, I have been informed that to anticipate, a prior art reference must contain an enabling disclosure that allows one of ordinary skill to practice the claims without undue experimentation.

597. I have reviewed the Gerpheide '658 patent from this perspective.

598. In my opinion, the Gerpheide '658 patent discloses to one of ordinary skill in the art how to practice or carry out the claims identified above in sufficient detail, without requiring

¹¹ In my opinion, a person of ordinary skill in the art would not understand the preamble of claim 9 to breathe life into that claim, and note that the "mobile telephone" and "digital audio player" portions of these respective preambles bear no relation whatsoever to any of the limitations in the bodies of these claims, which are otherwise identical to claim 1.

SUBJECT TO PROTECTIVE ORDER
CONTAINS HIGHLY CONFIDENTIAL – ATTORNEYS' EYES ONLY INFORMATION

undue experimentation. In fact, the disclosures of the Gerpheide '658 patent are greater than or equal to the disclosures in the '129 Patent itself.

599. Exhibit 129-2 provides a limitation-by-limitation analysis of the Gerpheide '658 patent, and is incorporated by reference into this Report.

3. Velos (Exhibit 129-3)

600. In my opinion, the Velos system publicly disclosed, used in public, sold, and/or offered for sale no later than December 2005 embodied each and every limitation of claims 1, 3, 5, 10, 12, 14, 17, 19, 21-22 of the '129 Patent regardless of whether the respective preambles of these claims are held to be limiting, and therefore anticipates these claims. In my opinion, the Velos system also embodied each and every limitation of claim 9 to the extent the preamble of that claim is not held to be limiting.¹²

601. As I discussed above, I have been informed that to anticipate, a prior art reference must contain an enabling disclosure that allows one of ordinary skill to practice the claims without undue experimentation.

602. I have reviewed the Velos system from this perspective, including the documentation produced by Atmel and the deposition testimony of Samuel Brunet.

603. In my opinion, the Velos system discloses to one of ordinary skill in the art how to practice or carry out the claims I identified above in sufficient detail, without requiring undue experimentation. The disclosures of the Velos system, as publicly disclosed, used in public, sold, and/or offered for sale in the United States, are greater than or equal to the disclosures in the '129 Patent itself.

¹² In my opinion, a person of ordinary skill in the art would not understand the preamble of claim 9 to breathe life into that claim, and note that the "mobile telephone" and "digital audio player" portions of these respective preambles bear no relation whatsoever to any of the limitations in the bodies of these claims, which are otherwise identical to claim 1.

**SUBJECT TO PROTECTIVE ORDER
CONTAINS HIGHLY CONFIDENTIAL – ATTORNEYS’ EYES ONLY INFORMATION**

604. Exhibit 129-3 provides a limitation-by-limitation analysis of the Velos system and is incorporated by reference into this report.

4. Philipp '898 (Exhibit 129-4)

605. In my opinion, the Philipp '898 patent, a United States patent filed September 18 2006 that claims priority to a provisional application filed September 30, 2005 and issued on April 26, 2011, discloses and enables each and every limitation of claims 1, 3, 5, 7, 9-10, 12, 14, 16-17, 19, 21-22, 24-26, and 28 regardless of whether the respective preambles of these claims are held to be limiting, and therefore anticipates these claims.

606. I have reviewed U.S. Provisional Application No. 60/722,477, to which the Philipp '898 patent claims priority, and have found it to support each and every anticipatory disclosure of the Philipp '898 patent.¹³

607. As I discussed above, I have been informed that to anticipate, a prior art reference must contain an enabling disclosure that allows one of ordinary skill to practice the claims without undue experimentation. I have been informed that for a United States Patent to be prior art as of the date of a provisional application to which it claims priority, the provisional application must provide written support for the anticipatory disclosures of the patent itself.

608. I have reviewed the Philipp '898 patent and the provisional application to which Philipp '898 claims priority from this perspective.

609. In my opinion, the Philipp '898 patent, as supported by the provisional application to which it claims priority, discloses to one of ordinary skill in the art how to practice or carry

¹³ It appears to me that the disclosure of the provisional application to which the Philipp '898 patent claims priority is nearly identical (if not actually identical) to the disclosure of the Philipp '898 patent itself. I did not do a word-for-word compare of the two disclosures, so I am not certain they are actually identical. However, I note that the substantive disclosures of the Philipp '898 patent and the provisional to which it claims priority are virtually identical in all respects material to the asserted claims.

SUBJECT TO PROTECTIVE ORDER
CONTAINS HIGHLY CONFIDENTIAL – ATTORNEYS’ EYES ONLY INFORMATION

out the claims identified above in sufficient detail, without requiring undue experimentation. In fact, the disclosures of the Philipp '898 patent are greater than or equal to the disclosures in the '129 Patent itself.

610. Exhibit 129-4 provides a limitation-by-limitation analysis of the Philipp '898 patent, and is incorporated by reference into this Report.

5. Hotelling '369 (Exhibit 129-5)

611. In my opinion, the Hotelling '369 publication, an international patent application publication¹⁴ published under the Patent Cooperation Treaty on December 1, 2005, discloses and enables each and every limitation of claims 1-3, 5, 7, 9-12, 14, 16-19, and 21-22 regardless of whether the respective preambles of these claims are held to be limiting, and therefore anticipates these claims.

612. As I discussed above, I have been informed that to anticipate, a prior art reference must contain an enabling disclosure that allows one of ordinary skill to practice the claims without undue experimentation.

613. I have reviewed the Hotelling '369 publication from this perspective.

614. In my opinion, the Hotelling '369 publication discloses to one of ordinary skill in the art how to practice or carry out the claims identified above in sufficient detail, without requiring undue experimentation.

615. Exhibit 129-5 provides a limitation-by-limitation analysis of the Hotelling '369 publication, and is incorporated by reference into this Report.

¹⁴ The Hotelling '369 publication is a Patent Cooperation Treaty publication of U.S. Patent No. 7,663,607 ("Hotelling '607"), which is cited and incorporated by reference in the '129 Patent.

**SUBJECT TO PROTECTIVE ORDER
CONTAINS HIGHLY CONFIDENTIAL – ATTORNEYS’ EYES ONLY INFORMATION**

B. Obviousness

616. It is my opinion that each of the Asserted Claims are rendered obvious by each of the five prior art references identified above. As discussed above and in Exhibits 129-1 through 129-5 attached and incorporated by reference to this report, every limitation in the Asserted Claims is taught by one or more of the GlidePoint System, Gerpheide '658, Velos, Philipp '898, or Hotelling '369 prior art patents and systems. To the extent those references do not anticipate all claims, they would have been obvious to one of ordinary skill in the art for the reasons outlined in the attached invalidity charts and the reasons below.

617. As mentioned above, the '129 is nothing more than an obvious modification of the disclosure in Hotelling '369, the counterpart to the '607 patent, that has already been held invalid. The '129 claims the following main features:

- a capacitive touch panel with two sets of traces oriented along different dimensions in a two-dimensional coordinate system, separated by a dielectric and with sensors at the points of intersection between the traces;
- drive and sense traces used to sense mutual capacitance;
- drive electrodes substantially wider than sense electrodes at least at a point of intersection between drive and sense electrodes;
- an LCD display capable of emitting a modulated Vcom signal; and
a computing system, digital audio player, or mobile telephone incorporating the capacitive touch panel.

618. Each of the above elements were well known in the art at the time of the '129 patent and I am prepared to testify about how those elements were known in the art at the time of the '129 invention. I am prepared to explain how the testimony of the inventors and Mr. Brunet

**SUBJECT TO PROTECTIVE ORDER
CONTAINS HIGHLY CONFIDENTIAL – ATTORNEYS’ EYES ONLY INFORMATION**

and Mr. Woolley establish that all elements claimed in the '129 patent were well known at least by December 2005.

XVII. INDEFINITENESS

619. In my opinion, claims 3, 12, 19, 22, 24-26 and 28 of the '129 patent are invalid as indefinite under 35 U.S.C. § 112, ¶ 2 because the intrinsic evidence fails to provide any objective standard for determining the scope and meaning of the term “substantially electrically isolate.”

620. I understand that claims are indefinite if they do not reasonably apprise those skilled in the relevant art of the applicant's intended scope of the invention when read in light of the specification. In my opinion, the phrase "substantially electrically isolate," as used in those claims do not reasonably apprise those skilled in the relevant art of its scope.

621. As explained above, it is my understanding that a claim is indefinite if it is “insolubly ambiguous.” The law requires that “[s]ome objective standard must be provided in order to allow the public to determine the scope of the claimed invention.” For example, I understand the Federal Circuit has held a claim indefinite where the specification fails to provide a guideline or testing methodology that would allow one skilled in the art to determine if an accused product practices certain limitations within the claim. *See Halliburton Energy Servs., Inc. v. M-I LLC*, 514 F.3d 1244, 1250-56 (Fed. Cir. 2008) (affirming finding of indefiniteness for claims using the term “fragile gel” because it was “ambiguous as to the requisite degree of the fragileness of the gel.”); *Honeywell Int’l v. Int’l Trade Comm’n*, 341 F.3d at 1332, 1342 (Fed. Cir. 2003) (affirming finding of indefiniteness for claims using the term “melting point elevation” (or “MPE”) because “neither the claims, the written description, nor the prosecution history reference any of the four sample preparation methods that can be used to measure the MPE.”).

**SUBJECT TO PROTECTIVE ORDER
CONTAINS HIGHLY CONFIDENTIAL – ATTORNEYS’ EYES ONLY INFORMATION**

622. It is my opinion that, as in the *Halliburton* and *Honeywell* cases, the claims, written description, and prosecution history of the ‘129 patent all fail to provide any method for measuring or objective standard for determining whether a set of traces is “substantially electrically isolated” from an underlying source of interference as required by claims , 12, 19, 22, 24-26 and 28. For the following reasons, a person of ordinary skill in the art would not be able to ascertain whether an accused product infringes claims containing the “substantially electrically isolate” limitation.

623. First, the phrase “substantially electrically isolate” is not a term of art. In my experience with touchscreen technologies and touch sensor panels, not once have I heard the term “substantially electrically isolate” used in the context of separating a sensor layer from a source of interference. As such, I do not believe that a person of ordinary skill in the art would understand the meaning of the phrase “substantially electrically isolate,” nor would he be aware of any known methods or tests for determining whether a device exhibits “substantial electrical isolation.” Indeed, I find it strange that the claims at issue refer to “electrical” isolation, as opposed to “electromagnetic” isolation; the former refers to a physical separation of two conductors so that no current can flow between them, whereas the latter refers to a transmission of electric fields, such as the interference or capacitive coupling that are at the heart of the ‘129 patent. It is not surprising, then, that the written description does not once use the phrase “substantially electrically isolate” – instead the phrase was added to the claims without comment or explanation during prosecution of the ‘129 patent.

624. [REDACTED]

[REDACTED]

[REDACTED]

[REDACTED]

[REDACTED]

[REDACTED]

[REDACTED]

[REDACTED]

[REDACTED]

[REDACTED]

[REDACTED]

[REDACTED]

[REDACTED]

[REDACTED]

XVIII. MISCELLANEOUS

A. Supplementation of Opinions

625. I understand that some discovery is still ongoing and Judge Koh has yet to issue a decision construing disputed claim terms, and Apple has not yet articulated its infringement theories or its responses to my invalidity opinions. Therefore, I reserve the right to adjust or supplement my opinions after I have had the opportunity to review further deposition testimony, additional documents that brought to my attention, and any claim construction decision.

B. Compensation

626. For purposes of this litigation, Samsung is compensating me for my time at the rate of \$575 per hour. My compensation is not contingent upon my performance, the outcome of this litigation, or any issues involved in or related to this litigation.

Dated: April 5, 2012

**SUBJECT TO PROTECTIVE ORDER
CONTAINS HIGHLY CONFIDENTIAL – ATTORNEYS’ EYES ONLY INFORMATION**

A handwritten signature in cursive script, reading "Brian Von Herzen", is written over a horizontal line.

Dr. Brian Von Herzen