

# Exhibit 7

## Part 2 of 2

## ViewPad 1000

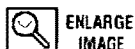

[Overview](#) | [Features](#) | [Specs](#) | [Accessories](#)

The ViewPad 1000 is a network-ready PC in a tablet form factor featuring built-in WAN, LAN and WiFi™ wireless connectivity. The ViewPad 1000 is ideally suited for value-added resellers and system integrators selling mobile vertical market applications. This innovative device offers mobile access to information whether you're in the office or on the road. And with its built-in digital camera, you can capture, send and receive live images from anywhere. The 10.4" high-resolution touch screen allows easy navigation. And at just 4.3 pounds, you can bring your office with you.

### ViewPad™ products in the workplace

See how businesses, just like yours are [using the ViewPad 1000](#).



### Features

#### ViewCare<sup>SM</sup> Warranty & Service Programs

When you need us most we're there for you. Get extra protection for your ViewSonic Tablet PC, choose from Extended Warranty, Express Exchange, Extended Warranty with Express Exchange or Accidental Damage Insurance programs.

[Buy Now](#)



#### The power of a fully functional PC in a tablet form factor

- Performance optimized for mainstream mobile computing use.
- Brings the ease of use of pen and paper to mobile computing.
- Weighs about 4 pounds.

#### Multiple connectivity features

- Includes built-in support for wireless, wired and dial-up networking.
- Includes wireless keyboard with integrated pointing device.

#### Product Details

- [Overview](#)
- [Features](#)
- [Specs](#)
- [Accessories](#)
- [Awards](#)
- [Press Release](#)
- [Awards](#)

 [PDF Product Comparison Chart \(507 K\)](#)

 [PDF Specs sheet \(107 K\)](#)

 [PDF User Guide \(2.3 MB\)](#)

 [Download Drivers/Utilities](#)

 [Print This Page](#)

 [Email This Page](#)

- Optional ViewPad 1000 Dock adds one-touch access to common computer peripherals, local area networks, integrated CD-ROM and AC power adapter.

### Take color pictures or record videos on the go

- The integrated camera enables you to add photos and video clips to presentations, documents and e-mail.

### High resolution 10.4" SVGA touch-screen display

- Delivers bright, crisp images providing a rich multimedia experience.
- Includes Pivot® software, enabling you to view the screen in portrait or landscape modes.

### One-year limited warranty on parts and labor

[Overview](#) | [Features](#) | [Specs](#) | [Accessories](#)

---

#### Specs

<b>Processor</b>		800MHz Intel® Mobile Celeron™
<b>Operating System</b>		Microsoft Windows® XP Professional Operating System
<b>Memory</b>	<b>SDRAM</b>	256MB (expandable to 512MB)
<b>Hard Disk Drive</b>		20.0GB
<b>Connectivity</b>		Built-in 802.11b Mini-PCI Wi-Fi™ LAN, RJ-11 56Kbps V.90 modem port, RJ-45 Fast Ethernet port
<b>Built-in Camera</b>		Digital CCD Camera (15fps streaming video and still photos)
<b>Graphics</b>		SIS630 Graphics Controller, AGP 4X Video
<b>Video Resolution</b>	<b>Built-in LCD Display</b>	800x600 in landscape mode 600x800 in portrait mode
	<b>External Display</b>	640x480 at 60Hz, 75Hz, 85Hz 800x600 at 60Hz, 75Hz, 85Hz 1024x768 at 60Hz, 75Hz, 85Hz
<b>Display</b>		High Luminance SVGA 10.4" TFT LCD Display
<b>Touch Panel</b>		Resistive Touch Screen
<b>Expansion Slots</b>		One Type II PC Card
<b>Audio</b>		18bit A / D stereo, 48KHz sampling rate, built-in microphone and two speakers
<b>System Ports</b>		Two Universal Serial Bus (USB) ports, one microphone and one Audio Out jack, VGA port, infrared data wireless keyboard port, infrared data port, 16-pin connector for ViewPad Dock
<b>One-Touch Access Buttons</b>		Power on, e-mail, Internet
<b>Input device</b>		Wireless keyboard with integrated pointing device
<b>Battery</b>		Rechargeable 5400 mAh Lithium Ion Battery Pack
<b>AC Adapter</b>		90 - 265V AC 50/60Hz; 16V DC Output Voltage; 2.0A 40W Power Output
<b>Dimensions</b>		12.2" x 8.9" x 1.4"; 310.5mm x 226.7mm x 36.2mm

<b>Weight</b>		4.3 lbs. / 1.95 kgs.
<b>Additional Software</b>	<b>Web Browser &amp; Applications</b>	Microsoft Internet Explorer 5.5
	<b>Productivity Applications</b>	Microsoft Outlook Express
	<b>Communication Applications</b>	Microsoft NetMeeting Citrix® ICA 6.0
	<b>Multimedia Applications</b>	Microsoft Windows Media Player
	<b>Additional Applications</b>	Pivot® Software from Portrait Displays, Inc. handwriting recognition software, virtual keyboard, Adobe Acrobat® Reader®

*Specifications and pricing subject to change without notice. Selection, offers and programs may vary by country; see your ViewSonic representative for complete details. Prices in U.S. dollars.*

[Overview](#) | [Features](#) | [Specs](#) | [Accessories](#)

Accessories

**ViewPad 1000 Dock**

Along with its built-in CD-ROM, the ViewPad 1000 Dock provides convenient connectivity to your LAN, AC power, USB Keyboard, MiniMouse and other common peripherals.



**ViewPad 1000 Battery**

Keep a spare handy for long trips without having to recharge.



**ViewPad 1000 Protective Handgrips**

Handgrips for easy holding and for outer protection.



**Tablet PC AC Adapter and Power Cord**

Charge your Tablet PC anywhere.



**ComboSaver™**

Secure and protect LCDs, projectors, and more with this secure keyless combination lock and cable from Kensington.



**Auto / Airline Adapters**

Charge your ViewPad while on the go.

BEST AVAILABLE COPY

ViewSonic has partnered with Lind to offer you the convenience of charging your ViewPad while on the road or in the air. [Click here for more details and to order.](#)



---

**Screen Protector (5-Pack)**

Give your screen an added layer of protection from fingerprints and dust, and minimize scratches with a Screen Protector.

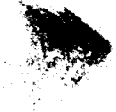

---

**ViewPad 1000 Stylus (3-Pack)**

Keep one at home, one in your briefcase and one in the office



---

**Slim MicroSaver® Security Cable**

Secure and protect LCDs, projectors, and more with this sleekly-designed, secure lock and cable from Kensington.



---

**ViewPad 1000 Case**



---

**Additional Memory, Flash and PC Card Drives**

ViewSonic has partnered with Kingston Technology to bring you reliable memory and digital media options. [Click here for more info or to order.](#)



---

**GoAmerica® Wireless Service**

Access nationwide wireless service with your ViewPad for secure access to email, corporate data and the world wide web.



---

[Overview](#) | [Features](#) | [Specs](#) | [Accessories](#)

[back to top](#)

BEST AVAILABLE COPY

IFW

**IN THE UNITED STATES PATENT AND TRADEMARK OFFICE**

In re application of: Andre et al.



Attorney Docket No.: APL1D297/P3297

Application No.: 29/201,636

Examiner: Freda S. Nunn

Filed: March 17, 2004

Group: 2911

Title: ELECTRONIC DEVICE

**CERTIFICATE OF MAILING**

I hereby certify that this correspondence is being deposited with the U.S. Postal Service with sufficient postage as first-class mail on September 8, 2004 in an envelope addressed to the Commissioner for Patents, P.O. Box 1450 Alexandria, VA 22313-1450.

Signed: \_\_\_\_\_

Agnes Spence

**INFORMATION DISCLOSURE STATEMENT  
37 CFR §§1.56 AND 1.97(b)**

Mail Stop Amendment  
Commissioner for Patents  
P.O. Box 1450  
Alexandria, VA 22313-1450

Dear Sir:

The references listed in the attached PTO Form 1449, copies of which are attached, may be material to examination of the above-identified patent application. Applicants submit these references in compliance with their duty of disclosure pursuant to 37 CFR §§1.56 and 1.97. The Examiner is requested to make these references of official record in this application.

This Information Disclosure Statement is not to be construed as a representation that a search has been made, that additional information material to the examination of this application does not exist, or that these references indeed constitute prior art.

This Information Disclosure Statement is: (i) filed within three (3) months of the filing date of the above-referenced application, (ii) believed to be filed before the mailing date of a first Office Action on the merits, or (iii) believed to be filed before the mailing of a first Office Action after the filing of a Request for Continued Examination under §1.114. Accordingly, it is believed that no fees are due in connection with the filing of this Information Disclosure Statement. However, if it is determined that any fees are due, the Commissioner is hereby authorized to charge such fees to Deposit Account 500388 (Order No. APL1D297).

Respectfully submitted,  
BEYER WEAVER & THOMAS, LLP

Quin C. Hoellwarth  
Registration No. 45,738

P.O. Box 778  
Berkeley, CA 94704-0778



<b>Form 1449 (Modified)</b>  <b>Information Disclosure Statement By Applicant</b>  (Use Several Sheets if Necessary)	Atty Docket No. APL1D297	Application No.: 29/201,636
	Applicant: Andre et al. Filing Date March 17, 2004	Group 2913

**U.S. Patent Documents**

Examiner Initial	No.	Patent No.	Date	Patentee	Class	Sub-class	Filing Date
	A						
	B						
	C						
	D						
	E						
	F						
	G						
	H						
	I						

**Foreign Patent or Published Foreign Patent Application**

Examiner Initial	No.	Document No.	Publication Date	Country or Patent Office	Class	Sub-class	Translation	
							Yes	No
	J							
	K							
	L							
	M							
	N							

**Other Documents**

Examiner Initial	No.	Author, Title, Date, Place (e.g. Journal) of Publication
	O	Andre et al., Patent Application No. 29/180,558 entitled "Electronic Device", filed March 17, 2004
	P	"HP Compaq Tablet PC tc1100", downloaded August 27, 2004.
	Q	"Tablet PC V1100", downloaded August 27, 2004.
		"ViewPad 1000", downloaded August 27, 2004.
Examiner		Date Considered

Examiner: Initial citation considered. Draw line through citation if not in conformance and not considered. Include copy of this form with next communication to applicant.



**UNITED STATES PATENT AND TRADEMARK OFFICE**

UNITED STATES DEPARTMENT OF COMMERCE  
 United States Patent and Trademark Office  
 Address: COMMISSIONER OF PATENTS AND TRADEMARKS  
 P.O. Box 1450  
 Alexandria, Virginia 22313-1450  
 www.uspto.gov

APPL NO.	FILING OR 371 (c) DATE	GRP ART UNIT	FIL FEE REC'D	ATTY. DOCKET NO	DRAWINGS	TOT CLMS	IND CLMS
29/180,558	04/25/2003	2900	460	APL1D274/P3103	3	1	1

22434  
 BEYER WEAVER & THOMAS LLP  
 P.O. BOX 778  
 BERKELEY, CA 94704-0778

**CONFIRMATION NO. 1353**  
**UPDATED FILING RECEIPT**  
  
 \*OC000000010717622\*

Date Mailed: 08/18/2003

Receipt is acknowledged of this regular Patent Application. It will be considered in its order and you will be notified as to the results of the examination. Be sure to provide the U.S. APPLICATION NUMBER, FILING DATE, NAME OF APPLICANT, and TITLE OF INVENTION when inquiring about this application. Fees transmitted by check or draft are subject to collection. Please verify the accuracy of the data presented on this receipt. **If an error is noted on this Filing Receipt, please write to the Office of Initial Patent Examination's Filing Receipt Corrections, facsimile number 703-746-9195. Please provide a copy of this Filing Receipt with the changes noted thereon. If you received a "Notice to File Missing Parts" for this application, please submit any corrections to this Filing Receipt with your reply to the Notice. When the USPTO processes the reply to the Notice, the USPTO will generate another Filing Receipt incorporating the requested corrections (if appropriate).**

**Applicant(s)**

- Bartley K. Andre, Menlo Park, CA;
- Daniel J. Coster, San Francisco, CA;
- Daniele De Iuliis, San Francisco, CA;
- Richard P. Howarth, San Francisco, CA;
- Jonathan P. Ive, San Francisco, CA;
- Duncan Robert Kerr, San Francisco, CA;
- Matthew Dean Rohrbach, San Francisco, CA;
- Douglas B. Satzger, San Carlos, CA;
- Calvin Q. Seid, Palo Alto, CA;
- Christopher J. Stringer, Pacifica, CA;
- Eugene Anthony Whang, San Francisco, CA;

**Domestic Priority data as claimed by applicant**

**Foreign Applications**

**If Required, Foreign Filing License Granted: 06/23/2003**

**Projected Publication Date:** None, application is not eligible for pre-grant publication

**Non-Publication Request:** No

**Early Publication Request:** No

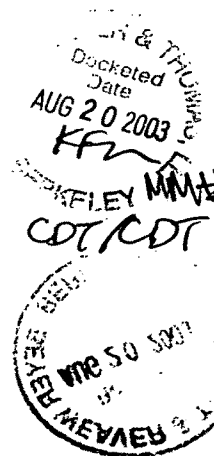



**Title**

Media device

**Preliminary Class**

D14

---

**LICENSE FOR FOREIGN FILING UNDER  
Title 35, United States Code, Section 184  
Title 37, Code of Federal Regulations, 5.11 & 5.15**

**GRANTED**

The applicant has been granted a license under 35 U.S.C. 184, if the phrase "IF REQUIRED, FOREIGN FILING LICENSE GRANTED" followed by a date appears on this form. Such licenses are issued in all applications where the conditions for issuance of a license have been met, regardless of whether or not a license may be required as set forth in 37 CFR 5.15. The scope and limitations of this license are set forth in 37 CFR 5.15(a) unless an earlier license has been issued under 37 CFR 5.15(b). The license is subject to revocation upon written notification. The date indicated is the effective date of the license, unless an earlier license of similar scope has been granted under 37 CFR 5.13 or 5.14.

This license is to be retained by the licensee and may be used at any time on or after the effective date thereof unless it is revoked. This license is automatically transferred to any related applications(s) filed under 37 CFR 1.53(d). This license is not retroactive.

The grant of a license does not in any way lessen the responsibility of a licensee for the security of the subject matter as imposed by any Government contract or the provisions of existing laws relating to espionage and the national security or the export of technical data. Licensees should apprise themselves of current regulations especially with respect to certain countries, of other agencies, particularly the Office of Defense Trade Controls, Department of State (with respect to Arms, Munitions and Implements of War (22 CFR 121-128)); the Office of Export Administration, Department of Commerce (15 CFR 370.10 (j)); the Office of Foreign Assets Control, Department of Treasury (31 CFR Parts 500+) and the Department of Energy.

**NOT GRANTED**

No license under 35 U.S.C. 184 has been granted at this time, if the phrase "IF REQUIRED, FOREIGN FILING LICENSE GRANTED" DOES NOT appear on this form. Applicant may still petition for a license under 37 CFR 5.12, if a license is desired before the expiration of 6 months from the filing date of the application. If 6 months has lapsed from the filing date of this application and the licensee has not received any indication of a secrecy order under 35 U.S.C. 181, the licensee may foreign file the application pursuant to 37 CFR 5.15(b).

**IN THE UNITED STATES PATENT AND TRADEMARK OFFICE**

Be It Known That We

Bartley K. Andre  
Daniel J. Coster  
Daniele De Iuliis  
Richard P. Howarth  
Jonathan P. Ive  
Duncan Robert Kerr  
Matthew Dean Rohrbach  
Douglas B. Satzger  
Calvin Q. Seid  
Christopher J. Stringer  
Eugene Anthony Whang

have invented a new, original, and ornamental design for a

**MEDIA DEVICE**

of which the following is a specification, reference being made to the accompanying drawings forming a part thereof.

## DESCRIPTION OF THE DRAWINGS

FIG. 1 is a perspective view of a media device in accordance with the present  
5 design. The media device can, for example, be a media player or a media storage  
device.

FIG. 2 is a front view for the media device.

FIG. 3 is a rear view for the media device.

FIG. 4 is a top view for the media device.

10 FIG. 5 is a bottom view for the media device.

FIG. 6 is a right side view for the media device.

FIG. 7 is a left side view for the media device.

15

## CLAIM

We claim the ornamental design for a **MEDIA DEVICE** substantially as  
shown and described.

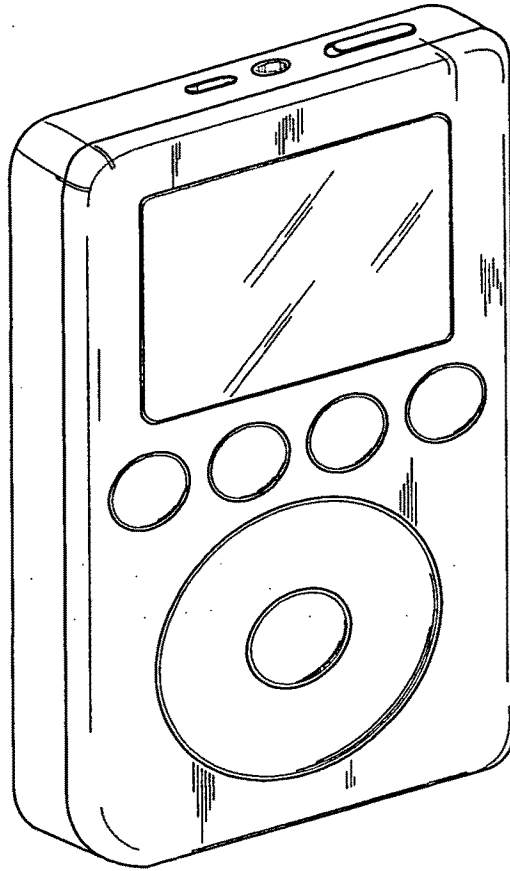

**FIG. 1**

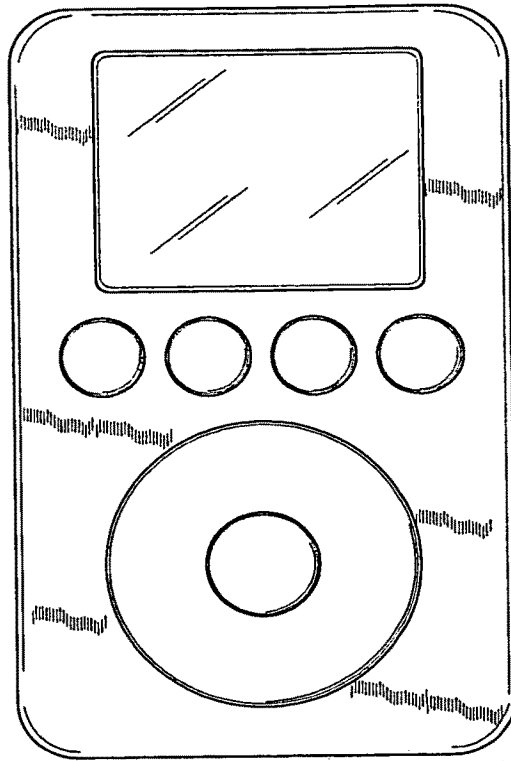

**FIG. 2**

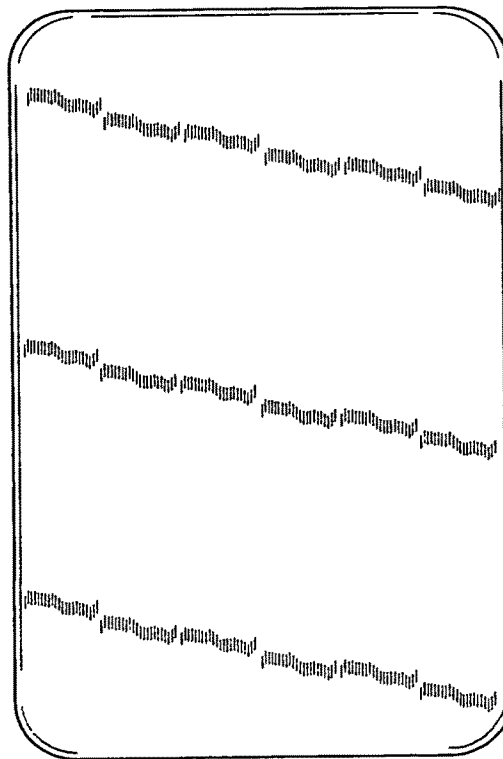

**FIG. 3**

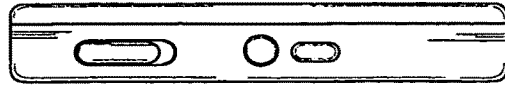

**FIG. 4**



**FIG. 5**



**FIG. 6**



**FIG. 7**

Day : Tuesday  
Date: 9/14/2004

Time: 15:44:06

**PALM INTRANET**

**Inventor Information for 29/201636**

Inventor Name	City	State/Country
ANDRE, BARTLEY K.	MENLO PARK	CALIFORNIA
COSTER, DANIEL J.	SAN FRANCISCO	CALIFORNIA
DE IULIIS, DANIELE	SAN FRANCISCO	CALIFORNIA
HOWARTH, RICHARD P.	SAN FRANCISCO	CALIFORNIA
IVE, JONATHAN P.	SAN FRANCISCO	CALIFORNIA
JOBS, STEVE	PALO ALTO	CALIFORNIA
NISHIBORI, SHIN	SAN FRANCISCO	CALIFORNIA
KERR, DUNCAN ROBERT	SAN FRANCISCO	CALIFORNIA
ROHRBACH, MATTHEW DEAN	SAN FRANCISCO	CALIFORNIA
SATZGER, DOUGLAS B.	MENLO PARK	CALIFORNIA
SEID, CALVIN Q.	PALO ALTO	CALIFORNIA
STRINGER, CHRISTOPHER J.	PORTOLA VALLEY	CALIFORNIA
WHANG, EUGENE ANTHONY	SAN FRANCISCO	CALIFORNIA
ZORKENDORFER, RICO	SAN FRANCISCO	CALIFORNIA

Appln Info	Contents	Petition Info	Atty/Agent Info	Continuity Data	Foreign Data
------------	----------	---------------	-----------------	-----------------	--------------

**Search Another: Application#**  **Search**
**or Patent#**  **Search**  
**PCT /**  **/**  **Search**
**or PG PUBS #**  **Search**  
**Attorney Docket #**  **Search**  
**Bar Code #**  **Search**

To go back use Back button on your browser toolbar.

Back to [PALM](#) | [ASSIGNMENT](#) | [OASIS](#) | [Home page](#)



UNITED STATES PATENT AND TRADEMARK OFFICE

UNITED STATES DEPARTMENT OF COMMERCE  
 United States Patent and Trademark Office  
 Address: COMMISSIONER FOR PATENTS  
 P.O. Box 1450  
 Alexandria, Virginia 22313-1450  
 www.uspto.gov



Bib Data Sheet

CONFIRMATION NO. 6966

SERIAL NUMBER 29/201,636	FILING DATE 03/17/2004  RULE	CLASS D14	GROUP ART UNIT 2911	ATTORNEY DOCKET NO. APL1D297
-----------------------------	---------------------------------------	--------------	------------------------	------------------------------------

APPLICANTS

Bartley K. Andre, Menlo Park, CA;  
 Daniel J. Coster, San Francisco, CA;  
 Daniele De Iuliis, San Francisco, CA; Richard P. Howarth, San Francisco, CA;  
 Jonathan P. Ive, San Francisco, CA;  
 Steve Jobs, Palo Alto, CA;  
 Shin Nishibori, San Francisco, CA;  
 Duncan Robert Kerr, San Francisco, CA;  
 Matthew Dean Rohrbach, San Francisco, CA;  
 Douglas B. Satzger, Menlo Park, CA;  
 Calvin Q. Seid, Palo Alto, CA;  
 Christopher J. Stringer, Portola Valley, CA;  
 Eugene Anthony Whang, San Francisco, CA;  
 Rico Zorkendorfer, San Francisco, CA;

\*\* CONTINUING DATA \*\*\*\*\* *NONE* *JON*

\*\* FOREIGN APPLICATIONS \*\*\*\*\* *NONE* *JON*

IF REQUIRED, FOREIGN FILING LICENSE GRANTED  
 \*\* 05/14/2004

Foreign Priority claimed <input type="checkbox"/> yes <input checked="" type="checkbox"/> no	STATE OR COUNTRY CA	SHEETS DRAWING 4	TOTAL CLAIMS 1	INDEPENDENT CLAIMS 1
35 USC 119 (a-d) conditions met <input type="checkbox"/> yes <input checked="" type="checkbox"/> no <input type="checkbox"/> Met after <i>allowance</i>				
Verified and Acknowledged Examiner's Signature <i>[Signature]</i> Initials <i>JON</i>				

ADDRESS  
 022434  
 BEYER WEAVER & THOMAS LLP  
 P.O. BOX 778  
 BERKELEY, CA  
 94704-0778

TITLE



Electronic device

FILING FEE RECEIVED 340	FEES: Authority has been given in Paper No. _____ to charge/credit DEPOSIT ACCOUNT No. _____ for following:	<input type="checkbox"/> All Fees <input type="checkbox"/> 1.16 Fees ( Filing ) <input type="checkbox"/> 1.17 Fees ( Processing Ext. of time ) <input type="checkbox"/> 1.18 Fees ( Issue ) <input type="checkbox"/> Other _____ <input type="checkbox"/> Credit
-------------------------------	---	--

**Search Notes**



Application/Control No.

29/201,636

Examiner

Freda S. Nunn

Applicant(s)/Patent under Reexamination

ANDRE ET AL.

Art Unit

2911

**SEARCHED**

Class	Subclass	Date	Examiner
D14	341-346, 374,424	11/3/2004	FSN
D19	26,59,60	↓	
345	104,156,		
	168,173		
434	307R,		
	308,309,		
	317		
178	18.03		
349	12		

**SEARCH NOTES  
(INCLUDING SEARCH STRATEGY)**

	DATE	EXMR
EAST Search	11/3/2004	FSN
Name Search	11/3/2004	FSN
Computer Pubs.	11/3/2004	FSN



**INTERFERENCE SEARCHED**

Class	Subclass	Date	Examiner
D14	341-346	11/3/2004	FSN

<b>Issue Classification</b> 	Application/Control No.	Applicant(s)/Patent under Reexamination	
	29/201,636	ANDRE ET AL.	
	Examiner	Art Unit	
	Freda S. Nunn	2911	

ISSUE CLASSIFICATION									
ORIGINAL				CROSS REFERENCE(S)					
CLASS	SUBCLASS			CLASS	SUBCLASS (ONE SUBCLASS PER BLOCK)				
D14	341								
INTERNATIONAL CLASSIFICATION									
			14/02						
			/						
			/						
			/						
			/						

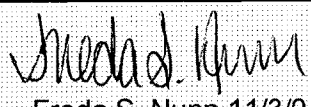
_____ (Assistant Examiner) (Date)	 Freda S. Nunn 11/3/04 (Primary Examiner) (Date)	<b>Total Claims Allowed: 1</b>				
 (Legal Instruments Examiner) (Date)		<table border="1"> <tr> <td>O.G. Print Claim(s)</td> <td>O.G. Print Fig.</td> </tr> <tr> <td style="text-align: center;">1</td> <td style="text-align: center;">1</td> </tr> </table>	O.G. Print Claim(s)	O.G. Print Fig.	1	1
O.G. Print Claim(s)	O.G. Print Fig.					
1	1					

<input type="checkbox"/> Claims renumbered in the same order as presented by applicant		<input type="checkbox"/> CPA		<input type="checkbox"/> T.D.		<input type="checkbox"/> R.1.47	
Final	Original	Final	Original	Final	Original	Final	Original
	1		31		61		91
	2		32		62		92
	3		33		63		93
	4		34		64		94
	5		35		65		95
	6		36		66		96
	7		37		67		97
	8		38		68		98
	9		39		69		99
	10		40		70		100
	11		41		71		101
	12		42		72		102
	13		43		73		103
	14		44		74		104
	15		45		75		105
	16		46		76		106
	17		47		77		107
	18		48		78		108
	19		49		79		109
	20		50		80		110
	21		51		81		111
	22		52		82		112
	23		53		83		113
	24		54		84		114
	25		55		85		115
	26		56		86		116
	27		57		87		117
	28		58		88		118
	29		59		89		119
	30		60		90		120
							121
							122
							123
							124
							125
							126
							127
							128
							129
							130
							131
							132
							133
							134
							135
							136
							137
							138
							139
							140
							141
							142
							143
							144
							145
							146
							147
							148
							149
							150
							151
							152
							153
							154
							155
							156
							157
							158
							159
							160
							161
							162
							163
							164
							165
							166
							167
							168
							169
							170
							171
							172
							173
							174
							175
							176
							177
							178
							179
							180
							181
							182
							183
							184
							185
							186
							187
							188
							189
							190
							191
							192
							193
							194
							195
							196
							197
							198
							199
							200
							201
							202
							203
							204
							205
							206
							207
							208
							209
							210

APPLICANTS' COPY  
29/201636



<b>Form 1449 (Modified)</b>  <b>Information Disclosure Statement By Applicant</b>  (Use Several Sheets if Necessary)	Atty Docket No. APL1D297	Application No.: 29/201,636
	Applicant: Andre et al. Filing Date March 17, 2004	Group 2913

**U.S. Patent Documents**

Examiner Initial	No.	Patent No.	Date	Patentee	Class	Sub-class	Filing Date
	A						
	B						
	C						
	D						
	E						
	F						
	G						
	H						
	I						

**Foreign Patent or Published Foreign Patent Application**

Examiner Initial	No.	Document No.	Publication Date	Country or Patent Office	Class	Sub-class	Translation	
							Yes	No
	J							
	K							
	L							
	M							
	N							

**Other Documents**

Examiner Initial	No.	Author, Title, Date, Place (e.g. Journal) of Publication
FAV	O	Andre et al., Patent Application No. 29/180,558 entitled "Electronic Device", filed March 17, 2004
↓	P	"HP Compaq Tablet PC tc1100", downloaded August 27, 2004.
↓	Q	"Tablet PC V1100", downloaded August 27, 2004.
FAV		"ViewPad 1000", downloaded August 27, 2004.
Examiner	Date Considered	
Frada S. Nunn	11/3/04	

Examiner: Initial citation considered. Draw line through citation if not in conformance and not considered. Include copy of this form with next communication to applicant.

**Notice of References Cited**

Application/Control No. 29/201,636	Applicant(s)/Patent Under Reexamination ANDRE ET AL.	
Examiner Freda S. Nunn	Art Unit 2911	Page 1 of 1

**U.S. PATENT DOCUMENTS**

*		Document Number Country Code-Number-Kind Code	Date MM-YYYY	Name	Classification
*	A	US-D345,346	03-1994	Alfonso et al.	D14/341
*	B	US-D396,452	07-1998	Naruki, Masatomo	D14/424
*	C	US-D451,505	12-2001	Iseki et al.	D14/341
*	D	US-D453,333	02-2002	Chen, Yu-Bing	D14/374
*	E	US-D458,252	06-2002	Palm et al.	D14/343
	F	US-			
	G	US-			
	H	US-			
	I	US-			
	J	US-			
	K	US-			
	L	US-			
	M	US-			

**FOREIGN PATENT DOCUMENTS**

*		Document Number Country Code-Number-Kind Code	Date MM-YYYY	Country	Name	Classification
	N					
	O					
	P					
	Q					
	R					
	S					
	T					

**NON-PATENT DOCUMENTS**

*		Include as applicable: Author, Title Date, Publisher, Edition or Volume, Pertinent Pages)
	U	
	V	
	W	
	X	

\*A copy of this reference is not being furnished with this Office action. (See MPEP § 707.05(a).)  
 Dates in MM-YYYY format are publication dates. Classifications may be US or foreign.

Applicants' Copy  
29/201,636

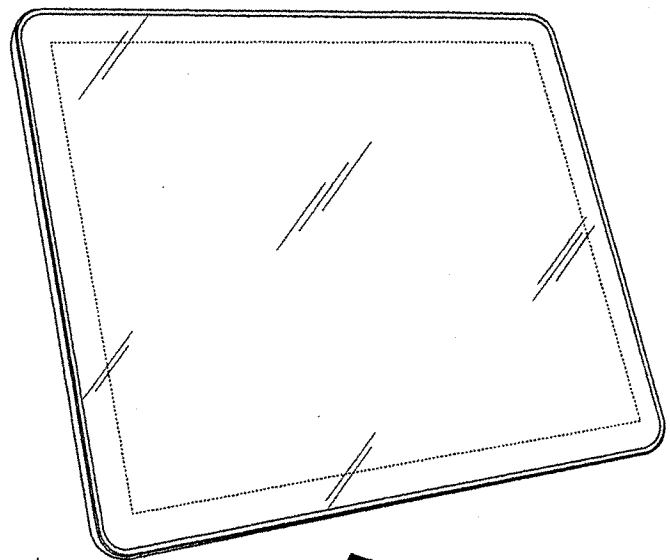

FIG. 1A

① Renumber all figures as indicated.

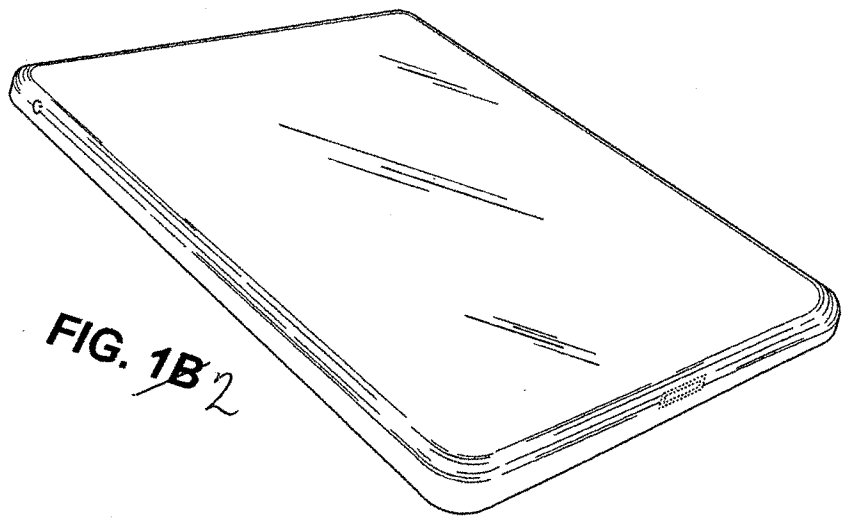
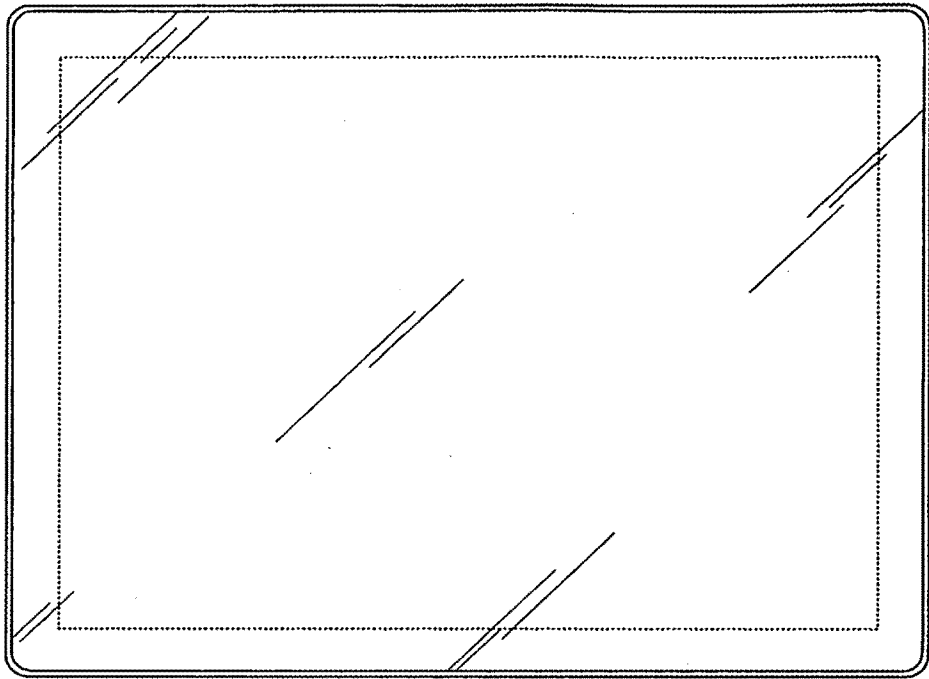
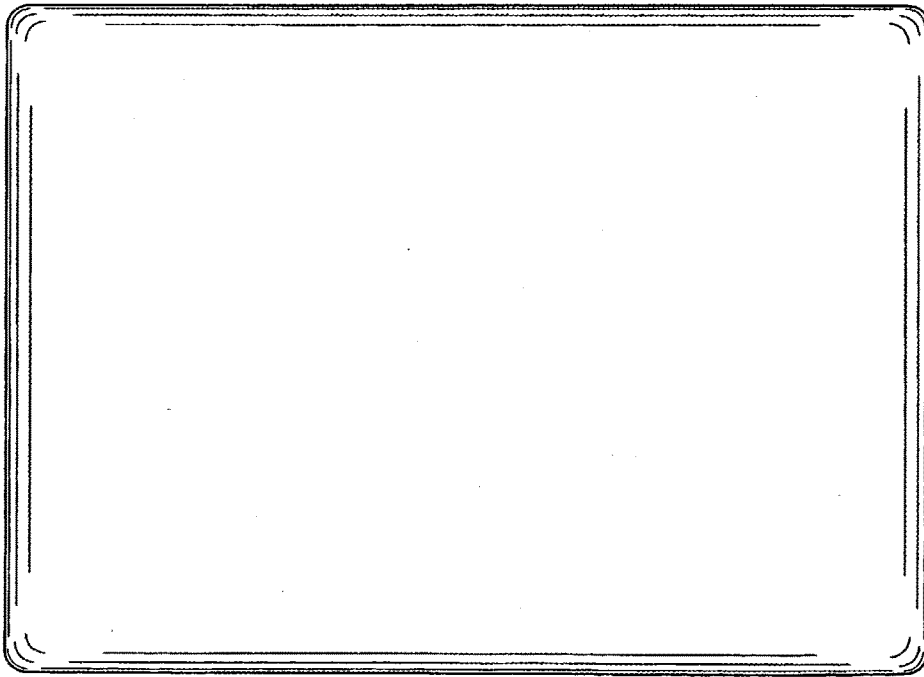

FIG. 1B



**FIG. 2** 3



**FIG. 3** 4



**FIG. 4** 5

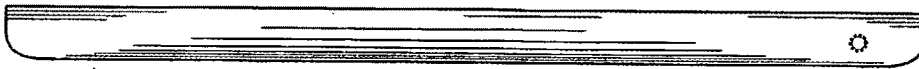

**FIG. 5** 6



**FIG. 6** 7



**FIG. 7** 8





Reduce human figure to broken lines.

FIG. 89

**Notice of Allowability**

Application No.

29/201,636

Examiner

Freda S. Nunn

Applicant(s)

ANDRE ET AL.

Art Unit

2911

**-- The MAILING DATE of this communication appears on the cover sheet with the correspondence address--**

All claims being allowable, PROSECUTION ON THE MERITS IS (OR REMAINS) CLOSED in this application. If not included herewith (or previously mailed), a Notice of Allowance (PTOL-85) or other appropriate communication will be mailed in due course. **THIS NOTICE OF ALLOWABILITY IS NOT A GRANT OF PATENT RIGHTS.** This application is subject to withdrawal from issue at the initiative of the Office or upon petition by the applicant. See 37 CFR 1.313 and MPEP 1308.

- 1.  This communication is responsive to \_\_\_\_\_.
- 2.  The allowed claim(s) is/are 1.
- 3.  The drawings filed on \_\_\_\_\_ are accepted by the Examiner.
- 4.  Acknowledgment is made of a claim for foreign priority under 35 U.S.C. § 119(a)-(d) or (f).
  - a)  All b)  Some\* c)  None of the:
    - 1.  Certified copies of the priority documents have been received.
    - 2.  Certified copies of the priority documents have been received in Application No. \_\_\_\_\_.
    - 3.  Copies of the certified copies of the priority documents have been received in this national stage application from the International Bureau (PCT Rule 17.2(a)).

\* Certified copies not received: \_\_\_\_\_.

Applicant has THREE MONTHS FROM THE "MAILING DATE" of this communication to file a reply complying with the requirements noted below. Failure to timely comply will result in ABANDONMENT of this application.  
**THIS THREE-MONTH PERIOD IS NOT EXTENDABLE.**

- 5.  A SUBSTITUTE OATH OR DECLARATION must be submitted. Note the attached EXAMINER'S AMENDMENT or NOTICE OF INFORMAL PATENT APPLICATION (PTO-152) which gives reason(s) why the oath or declaration is deficient.
  - 6.  CORRECTED DRAWINGS ( as "replacement sheets") must be submitted.
    - (a)  including changes required by the Notice of Draftsperson's Patent Drawing Review ( PTO-948) attached
      - 1)  hereto or 2)  to Paper No./Mail Date \_\_\_\_\_.
    - (b)  including changes required by the attached Examiner's Amendment / Comment or in the Office action of Paper No./Mail Date \_\_\_\_\_.
- Identifying indicia such as the application number (see 37 CFR 1.84(c)) should be written on the drawings in the front (not the back) of each sheet. Replacement sheet(s) should be labeled as such in the header according to 37 CFR 1.121(d).**
- 7.  DEPOSIT OF and/or INFORMATION about the deposit of BIOLOGICAL MATERIAL must be submitted. Note the attached Examiner's comment regarding REQUIREMENT FOR THE DEPOSIT OF BIOLOGICAL MATERIAL.

**Attachment(s)**

- 1.  Notice of References Cited (PTO-892)
- 2.  Notice of Draftsperson's Patent Drawing Review (PTO-948)
- 3.  Information Disclosure Statements (PTO-1449 or PTO/SB/08), Paper No./Mail Date 0
- 4.  Examiner's Comment Regarding Requirement for Deposit of Biological Material
- 5.  Notice of Informal Patent Application (PTO-152)
- 6.  Interview Summary (PTO-413), Paper No./Mail Date \_\_\_\_\_
- 7.  Examiner's Amendment/Comment
- 8.  Examiner's Statement of Reasons for Allowance
- 9.  Other sketches attached.

Art Unit: 2911

An examiner's amendment to the record appears below. Should the changes and/or additions be unacceptable to applicant, an amendment may be filed as provided by *37 CFR 1.312*. To ensure consideration of such an amendment, it MUST be submitted no later than the payment of the issue fee.

Because the drawing is its own best description, the description of FIG. 1 is deemed superfluous and has therefore been canceled. Also, for a definite disclosure and proper numbering, the figure descriptions have been (*37 C.F.R 1.153*) amended to read:

FIG. 1 is a top perspective view of an electronic device in accordance with the present design;  
FIG. 2 is a bottom perspective view thereof;  
FIG. 3 is a top view thereof;  
FIG. 4 is a bottom view thereof;  
FIG. 5 is a left side view thereof;  
FIG. 6 is a right side view thereof;  
FIG. 7 is an upper side view thereof;  
FIG. 8 is a lower side view thereof;  
FIG. 9 is an exemplary diagram of the use of the electronic device thereof the broken lines being shown for illustrative purposes only and form no part of the claimed design.

Furthermore, the inclusion of the statement regarding the appendix is not proper for the specification of a Design Patent application. Therefore, said statement has been cancelled, *37 CFR 1.153*.

The drawing disclosure is objectionable because FIGS. 1A-8 have not been properly numbered and, the human figure has not been reduced to broken lines. Therefore, to overcome the objection, the figures currently numbered as FIGS. 1A-8 must be renumbered as FIGS. 1-9. Also, because the human figure is only being shown for illustrative purposes, said figure must be reduced to broken lines. Note the attached sketches. Correction is required, *37 CFR 1.84*.

When preparing new drawings in compliance with the requirement therefor, care must be exercised to avoid introduction of anything which could be construed to be new matter prohibited by *35 U.S.C. 132* and *37 CFR 1.121*.

Any inquiry concerning this communication or earlier communications from the examiner should be directed to Freda S. Nunn, whose telephone number is (571) 272-2607. The examiner can normally be reached on Monday – Thursday, and alternate Fridays from 7:00 am to 4:00 pm

If attempts to reach the examiner by telephone are unsuccessful, the examiner's supervisor, Alan Douglas, can be reached at (571) 272-2588. The FAX phone number for this group is (703)-872-9306.

Art Unit: 2911

Information regarding the status of an application may be obtained from the Patent Application Information Retrieval (PAIR) system. Status information for published applications may be obtained from either Private PAIR or Public PAIR. Status information for unpublished applications is available through Private PAIR only. For more information about the PAIR system, see <http://pair-direct.uspto.gov>. Should you have questions on access to the Private PAIR system, contact the Electronic Business Center (EBC) at 866-217-9197 (toll-free).

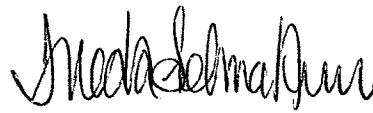

Freda Selma Nunn  
Primary Examiner  
Art Unit 2911



NOTICE OF ALLOWANCE AND FEE(S) DUE

022434 7590 11/17/2004

BEYER WEAVER & THOMAS LLP  
P.O. BOX 778  
BERKELEY, CA 94704-0778

EXAMINER

NUNN, FREDA S

ART UNIT PAPER NUMBER

2911

DATE MAILED: 11/17/2004

APPLICATION NO.	FILING DATE	FIRST NAMED INVENTOR	ATTORNEY DOCKET NO.	CONFIRMATION NO.
29/201,636	03/17/2004	Bartley K. Andre	APLID297	6966

TITLE OF INVENTION: ELECTRONIC DEVICE

APPLN. TYPE	SMALL ENTITY	ISSUE FEE	PUBLICATION FEE	TOTAL FEE(S) DUE	DATE DUE
nonprovisional	NO	\$490	\$0	\$490	02/17/2005

THE APPLICATION IDENTIFIED ABOVE HAS BEEN EXAMINED AND IS ALLOWED FOR ISSUANCE AS A PATENT. **PROSECUTION ON THE MERITS IS CLOSED.** THIS NOTICE OF ALLOWANCE IS NOT A GRANT OF PATENT RIGHTS. THIS APPLICATION IS SUBJECT TO WITHDRAWAL FROM ISSUE AT THE INITIATIVE OF THE OFFICE OR UPON PETITION BY THE APPLICANT. SEE 37 CFR 1.313 AND MPEP 1308.

THE ISSUE FEE AND PUBLICATION FEE (IF REQUIRED) MUST BE PAID WITHIN **THREE MONTHS** FROM THE MAILING DATE OF THIS NOTICE OR THIS APPLICATION SHALL BE REGARDED AS ABANDONED. **THIS STATUTORY PERIOD CANNOT BE EXTENDED.** SEE 35 U.S.C. 151. THE ISSUE FEE DUE INDICATED ABOVE REFLECTS A CREDIT FOR ANY PREVIOUSLY PAID ISSUE FEE APPLIED IN THIS APPLICATION. THE PTOL-85B (OR AN EQUIVALENT) MUST BE RETURNED WITHIN THIS PERIOD EVEN IF NO FEE IS DUE OR THE APPLICATION WILL BE REGARDED AS ABANDONED.

HOW TO REPLY TO THIS NOTICE:

I. Review the SMALL ENTITY status shown above.

If the SMALL ENTITY is shown as YES, verify your current SMALL ENTITY status:

- A. If the status is the same, pay the TOTAL FEE(S) DUE shown above.
- B. If the status above is to be removed, check box 5b on Part B - Fee(s) Transmittal and pay the PUBLICATION FEE (if required) and twice the amount of the ISSUE FEE shown above, or

If the SMALL ENTITY is shown as NO:

- A. Pay TOTAL FEE(S) DUE shown above, or
- B. If applicant claimed SMALL ENTITY status before, or is now claiming SMALL ENTITY status, check box 5a on Part B - Fee(s) Transmittal and pay the PUBLICATION FEE (if required) and 1/2 the ISSUE FEE shown above.

II. PART B - FEE(S) TRANSMITTAL should be completed and returned to the United States Patent and Trademark Office (USPTO) with your ISSUE FEE and PUBLICATION FEE (if required). Even if the fee(s) have already been paid, Part B - Fee(s) Transmittal should be completed and returned. If you are charging the fee(s) to your deposit account, section "4b" of Part B - Fee(s) Transmittal should be completed and an extra copy of the form should be submitted.

III. All communications regarding this application must give the application number. Please direct all communications prior to issuance to Mail Stop ISSUE FEE unless advised to the contrary.

**IMPORTANT REMINDER: Utility patents issuing on applications filed on or after Dec. 12, 1980 may require payment of maintenance fees. It is patentee's responsibility to ensure timely payment of maintenance fees when due.**

**PART B - FEE(S) TRANSMITTAL**

Complete and send this form, together with applicable fee(s), to: **Mail**

**Mail Stop ISSUE FEE  
Commissioner for Patents  
P.O. Box 1450  
Alexandria, Virginia 22313-1450  
(703) 746-4000**

or **Fax**

**INSTRUCTIONS:** This form should be used for transmitting the ISSUE FEE and PUBLICATION FEE (if required). Blocks 1 through 5 should be completed where appropriate. All further correspondence including the Patent, advance orders and notification of maintenance fees will be mailed to the current correspondence address as indicated unless corrected below or directed otherwise in Block 1, by (a) specifying a new correspondence address; and/or (b) indicating a separate "FEE ADDRESS" for maintenance fee notifications.

CURRENT CORRESPONDENCE ADDRESS (Note: Use Block 1 for any change of address)

022434                      7590                      11/17/2004

**BEYER WEAVER & THOMAS LLP  
P.O. BOX 778  
BERKELEY, CA 94704-0778**

Note: A certificate of mailing can only be used for domestic mailings of the Fee(s) Transmittal. This certificate cannot be used for any other accompanying papers. Each additional paper, such as an assignment or formal drawing, must have its own certificate of mailing or transmission.

**Certificate of Mailing or Transmission**

I hereby certify that this Fee(s) Transmittal is being deposited with the United States Postal Service with sufficient postage for first class mail in an envelope addressed to the Mail Stop ISSUE FEE address above, or being facsimile transmitted to the USPTO (703) 746-4000, on the date indicated below.

(Depositor's name)
(Signature)
(Date)

APPLICATION NO.	FILING DATE	FIRST NAMED INVENTOR	ATTORNEY DOCKET NO.	CONFIRMATION NO.
29/201,636	03/17/2004	Bartley K. Andre	APL1D297	6966

TITLE OF INVENTION: ELECTRONIC DEVICE

APPLN. TYPE	SMALL ENTITY	ISSUE FEE	PUBLICATION FEE	TOTAL FEE(S) DUE	DATE DUE
nonprovisional	NO	\$490	\$0	\$490	02/17/2005

EXAMINER	ART UNIT	CLASS-SUBCLASS
NUNN, FREDAS	2911	D14-341000

<p>1. Change of correspondence address or indication of "Fee Address" (37 CFR 1.363).</p> <p><input type="checkbox"/> Change of correspondence address (or Change of Correspondence Address form PTO/SB/122) attached.</p> <p><input type="checkbox"/> "Fee Address" indication (or "Fee Address" Indication form PTO/SB/47; Rev 03-02 or more recent) attached. Use of a <b>Customer Number is required.</b></p>	<p>2. For printing on the patent front page, list</p> <p>(1) the names of up to 3 registered patent attorneys or agents OR, alternatively, _____ 1</p> <p>(2) the name of a single firm (having as a member a registered attorney or agent) and the names of up to 2 registered patent attorneys or agents. If no name is listed, no name will be printed. _____ 2</p> <p>_____ 3</p>
---	---

3. ASSIGNEE NAME AND RESIDENCE DATA TO BE PRINTED ON THE PATENT (print or type)

PLEASE NOTE: Unless an assignee is identified below, no assignee data will appear on the patent. If an assignee is identified below, the document has been filed for recordation as set forth in 37 CFR 3.11. Completion of this form is NOT a substitute for filing an assignment.

(A) NAME OF ASSIGNEE \_\_\_\_\_ (B) RESIDENCE: (CITY and STATE OR COUNTRY) \_\_\_\_\_

Please check the appropriate assignee category or categories (will not be printed on the patent) :  Individual  Corporation or other private group entity  Government

<p>4a. The following fee(s) are enclosed:</p> <p><input type="checkbox"/> Issue Fee</p> <p><input type="checkbox"/> Publication Fee (No small entity discount permitted)</p> <p><input type="checkbox"/> Advance Order - # of Copies _____</p>	<p>4b. Payment of Fee(s):</p> <p><input type="checkbox"/> A check in the amount of the fee(s) is enclosed.</p> <p><input type="checkbox"/> Payment by credit card. Form PTO-2038 is attached.</p> <p><input type="checkbox"/> The Director is hereby authorized by charge the required fee(s), or credit any overpayment, to Deposit Account Number _____ (enclose an extra copy of this form).</p>
--	---

5. Change in Entity Status (from status indicated above)

a. Applicant claims SMALL ENTITY status. See 37 CFR 1.27.  b. Applicant is no longer claiming SMALL ENTITY status. See 37 CFR 1.27(g)(2).

The Director of the USPTO is requested to apply the Issue Fee and Publication Fee (if any) or to re-apply any previously paid issue fee to the application identified above. NOTE: The Issue Fee and Publication Fee (if required) will not be accepted from anyone other than the applicant; a registered attorney or agent; or the assignee or other party in interest as shown by the records of the United States Patent and Trademark Office.

Authorized Signature \_\_\_\_\_ Date \_\_\_\_\_

Typed or printed name \_\_\_\_\_ Registration No. \_\_\_\_\_

This collection of information is required by 37 CFR 1.311. The information is required to obtain or retain a benefit by the public which is to file (and by the USPTO to process) an application. Confidentiality is governed by 35 U.S.C. 122 and 37 CFR 1.14. This collection is estimated to take 12 minutes to complete, including gathering, preparing, and submitting the completed application form to the USPTO. Time will vary depending upon the individual case. Any comments on the amount of time you require to complete this form and/or suggestions for reducing this burden, should be sent to the Chief Information Officer, U.S. Patent and Trademark Office, U.S. Department of Commerce, P.O. Box 1450, Alexandria, Virginia 22313-1450. DO NOT SEND FEES OR COMPLETED FORMS TO THIS ADDRESS. SEND TO: Commissioner for Patents, P.O. Box 1450, Alexandria, Virginia 22313-1450.

Under the Paperwork Reduction Act of 1995, no persons are required to respond to a collection of information unless it displays a valid OMB control number.



UNITED STATES PATENT AND TRADEMARK OFFICE

UNITED STATES DEPARTMENT OF COMMERCE  
United States Patent and Trademark Office  
Address: COMMISSIONER FOR PATENTS  
P.O. Box 1450  
Alexandria, Virginia 22313-1450  
www.uspto.gov

APPLICATION NO.	FILING DATE	FIRST NAMED INVENTOR	ATTORNEY DOCKET NO.	CONFIRMATION NO.
29/201,636	03/17/2004	Bartley K. Andre	APL1D297	6966

022434 7590 11/17/2004  
BEYER WEAVER & THOMAS LLP  
P.O. BOX 778  
BERKELEY, CA 94704-0778

EXAMINER

NUNN, FREDA S

ART UNIT PAPER NUMBER

2911

DATE MAILED: 11/17/2004

**Determination of Patent Term Extension or Adjustment under 35 U.S.C. 154 (b)**

Design patents have a term measured from the issue date of the patent and the term remains the same length regardless of the time that the application for the design patent was pending. Since the above-identified application is an application for a design patent, the patent is not eligible for Patent Term Extension or Adjustment under 35 U.S.C. 154(b).

Any questions regarding the Patent Term Extension or Adjustment determination should be directed to the Office of Patent Legal Administration at (703) 305-1383. Questions relating to issue and publication fee payments should be directed to the Customer Service Center of the Office of Patent Publication at (703) 305-8283.

# DESIGN ALLOWANCE HOT LIST

Appl. No. 29/201636  
Examiner-TC NUM 2900

Prepared by K. HARRIS  
Date 11/16 04

## JACKET:

YES  NO Primary Examiner box complete.  
 YES  NO Locarno Classification supplied.

## PTO-892/1449:

YES  NO Examiner's initials or cross-through lines supplied for each item cited by applicant.  
 YES  NO Date(s) supplied/complete on all PTO-1449/892 sheets. (Month and year required.)

## SPEC:

YES  NO Brief Description of Drawings includes description of each figure in drawings.  
 YES  NO Continuing data is mentioned in 1<sup>st</sup> paragraph. (Can be an insert.)

## TITLE:

YES  NO Title matches claim.

Jul-03





IN THE UNITED STATES PATENT AND TRADEMARK OFFICE

In re application of: Andre et al.

Attorney Docket No.: APL1D297

Application No.: 29/201,636

Examiner: Nunn, Freda S.

Filed: March 17, 2004

Group: 2911

Title: ELECTRONIC DEVICE

CERTIFICATE OF MAILING

I hereby certify that this correspondence is being deposited with the U.S. Postal Service with sufficient postage as first-class mail on February 11, 2005 in an envelope addressed to the Commissioner for Patents, P.O. Box 1450 Alexandria, VA 22313-1450.

Signed: \_\_\_\_\_

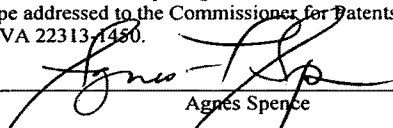
  
Agnes Spence

**SEPARATE LETTER TO THE OFFICIAL DRAFTSMAN  
REQUESTING ENTERING OF FORMAL DRAWINGS  
(MPEP 608.02(p))**

Commissioner for Patents  
P.O. Box 1450  
Alexandria, VA 22313-1450

Dear Sir:

In response to the objections made due to informalities in the original drawings (or to corrections approved by the Examiner), enclosed are substitute (formal) drawings for the above-identified patent application. If the Draftsman has any question concerning these drawings, he or she is respectfully requested to contact the undersigned.

Respectfully submitted,  
BEYER WEAVER & THOMAS, LLP

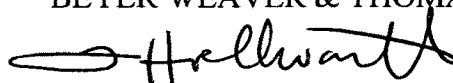

Quin C. Hoellwarth  
Registration No. 45,738

P.O. Box 70250  
Oakland, CA 94612-0250  
650-961-8300



29,201,636

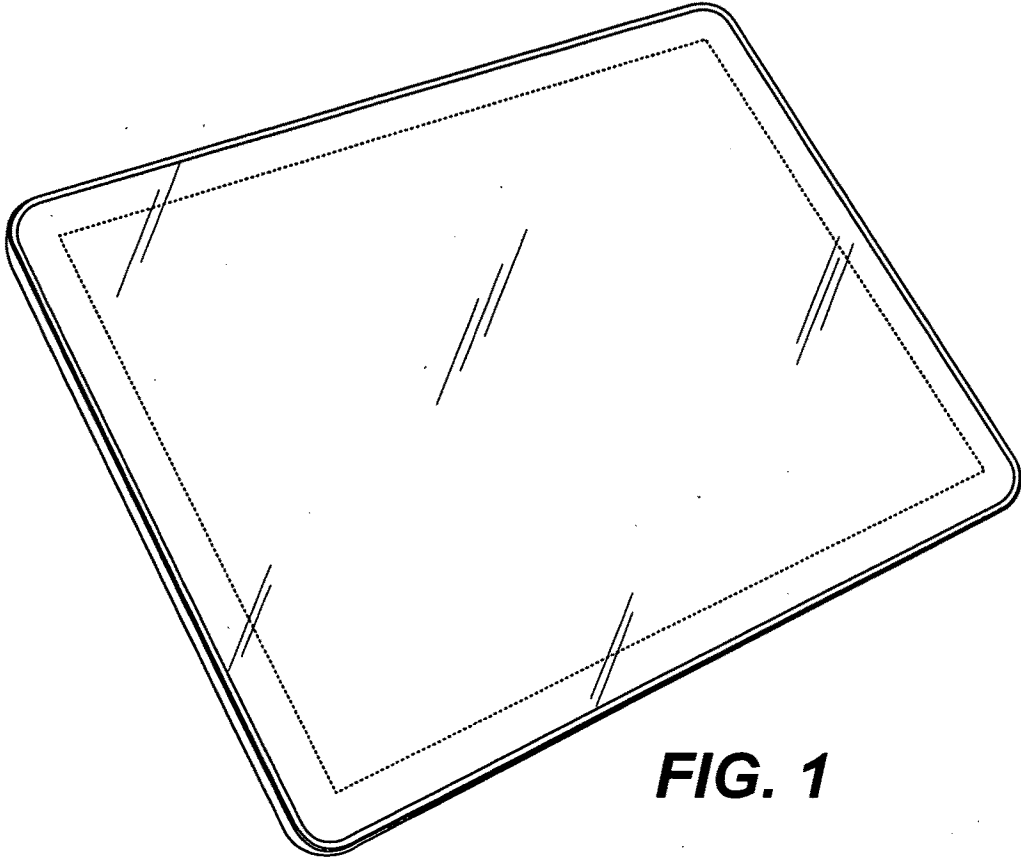

**FIG. 1**

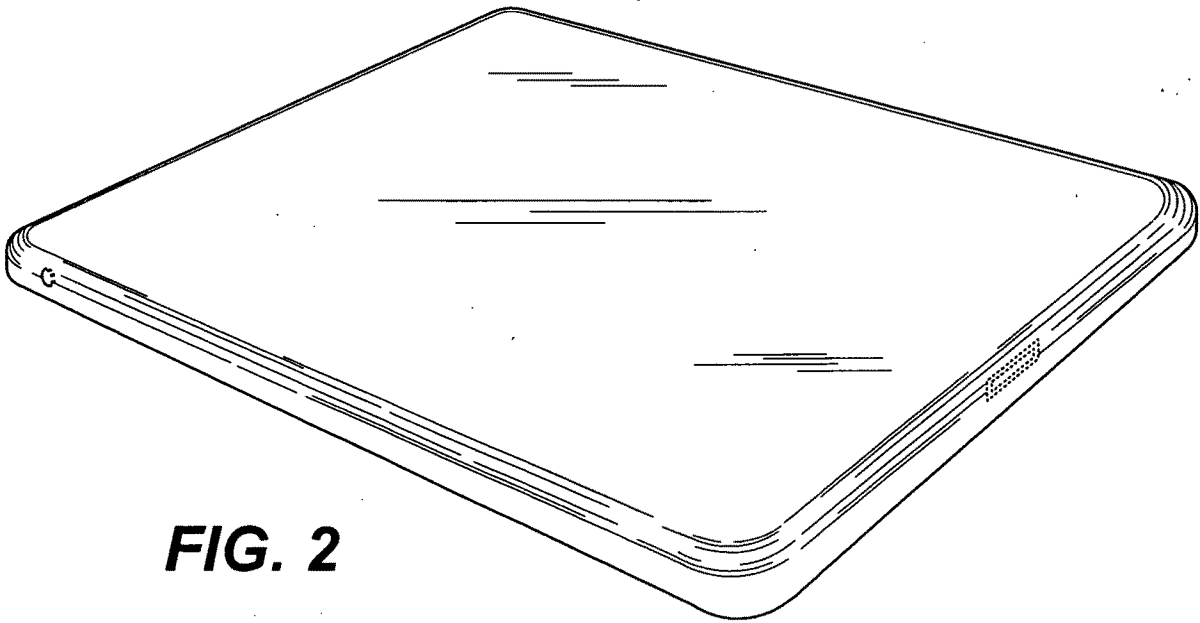
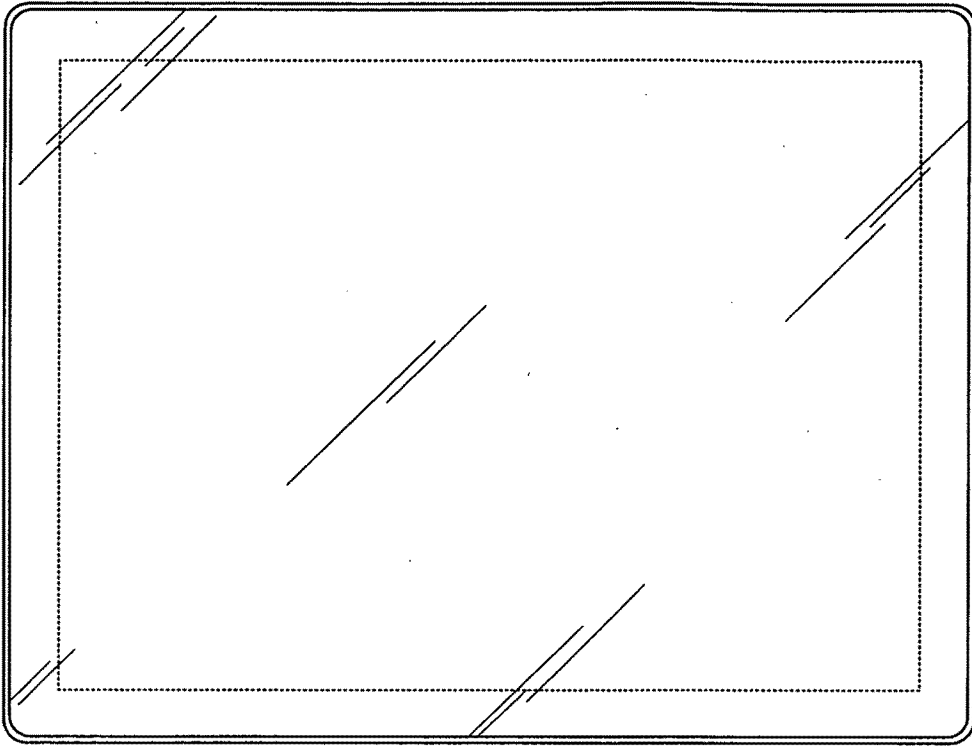

**FIG. 2**

BEST AVAILABLE COPY



29,201,636



**FIG. 3**

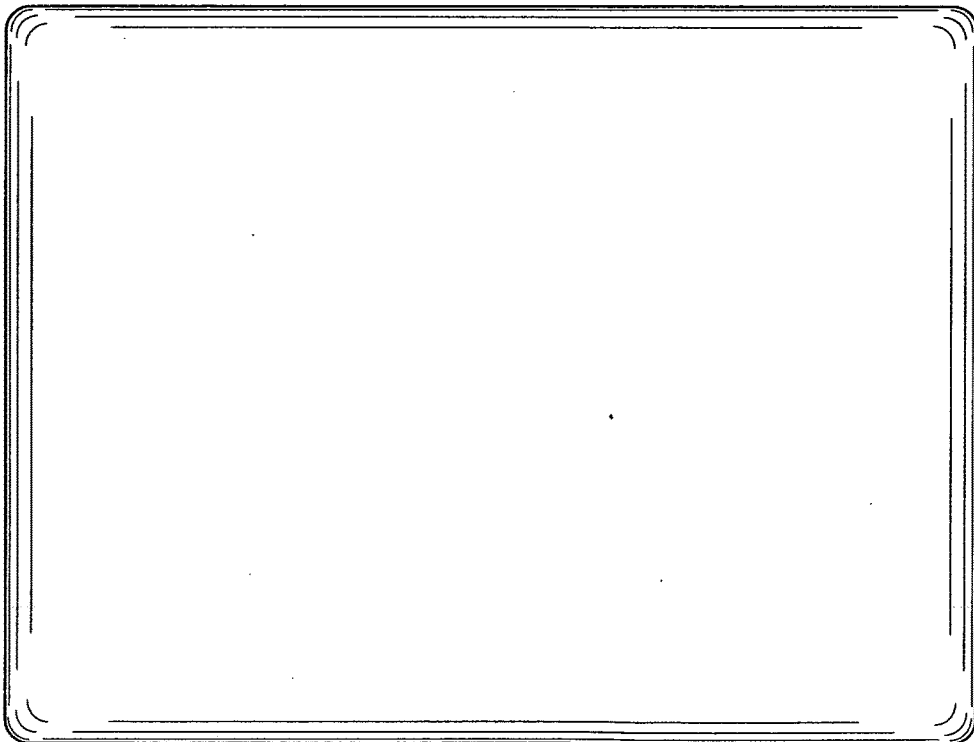

**FIG. 4**

BEST AVAILABLE COPY



2 11 2011 10 22



**FIG. 5**

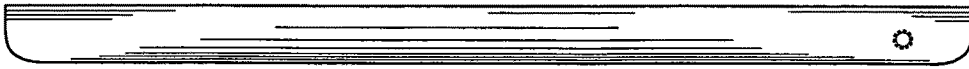

**FIG. 6**

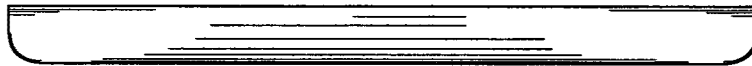

**FIG. 7**



**FIG. 8**

BEST AVAILABLE COPY

BEST AVAILABLE COPY

29,201,636

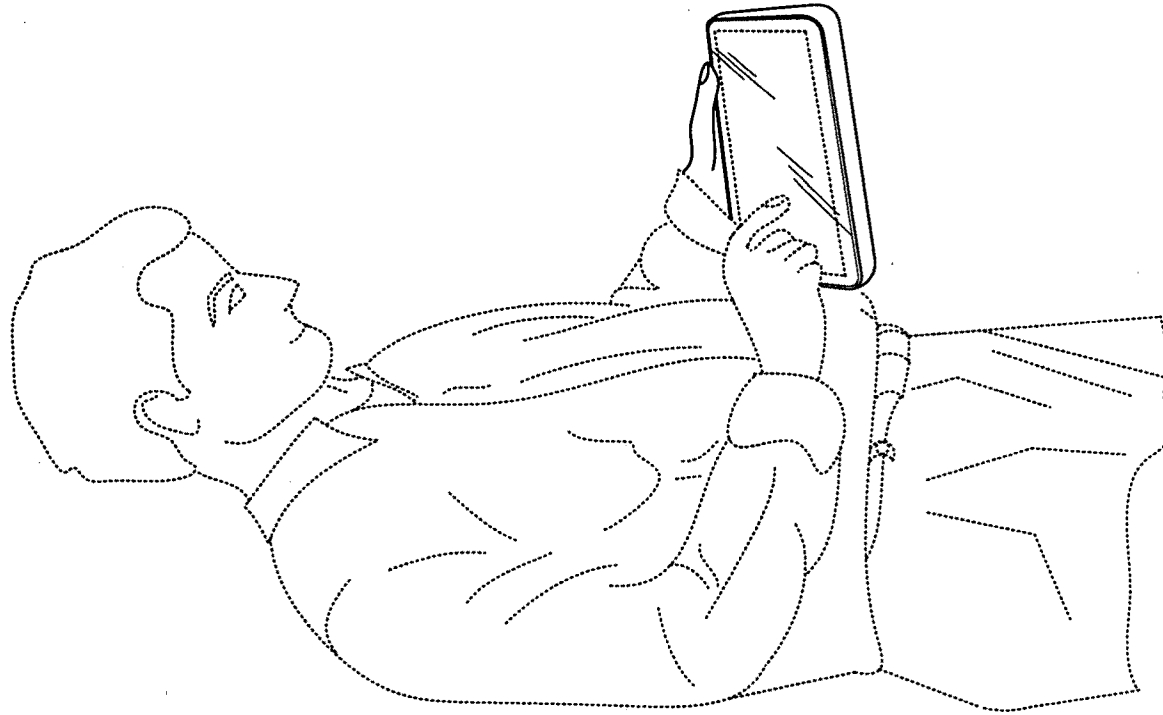

FIG. 9



PART B - FEE(S) TRANSMITTAL

Complete and send this form, together with applicable fee(s), to: **Mail** Mail Stop ISSUE FEE  
 Commissioner for Patents  
 P.O. Box 1450  
 Alexandria, Virginia 22313-1450  
 or **Fax** (703) 746-4000

INSTRUCTIONS: This form should be used for transmitting the ISSUE FEE and PUBLICATION FEE (if required). Blocks 1 through 5 should be completed where appropriate. All further correspondence including the Patent, advance orders and notification of maintenance fees will be mailed to the current correspondence address as indicated unless corrected below or directed otherwise in Block 1, by (a) specifying a new correspondence address; and/or (b) indicating a separate "FEE ADDRESS" for maintenance fee notifications.

CURRENT CORRESPONDENCE ADDRESS (Note: Use Block 1 for any change of address)

022434 7590 11/17/2004

BEYER WEAVER & THOMAS LLP  
 P.O. BOX 778  
 BERKELEY, CA 94704-0778

02/16/2005 SSITHIB2 00000029 29201636

01 FC:1502 800.00 DP  
 02 FC:8001 36.00 DP

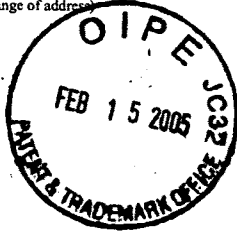

Note: A certificate of mailing can only be used for domestic mailings of the Fee(s) Transmittal. This certificate cannot be used for any other accompanying papers. Each additional paper, such as an assignment or formal drawing, must have its own certificate of mailing or transmission.

Certificate of Mailing or Transmission  
 I hereby certify that this Fee(s) Transmittal is being deposited with the United States Postal Service with sufficient postage for first class mail in an envelope addressed to the Mail Stop ISSUE FEE address above, or being facsimile transmitted to the USPTO (703) 746-4000, on the date indicated below.

Agnes Spence (Depositor's name)  
 Agnes Spence (Signature)  
 February 11, 2005 (Date)

APPLICATION NO.	FILING DATE	FIRST NAMED INVENTOR	ATTORNEY DOCKET NO.	CONFIRMATION NO.
29/201,636	03/17/2004	Bartley K. Andre	APL1D297	6966

TITLE OF INVENTION: ELECTRONIC DEVICE

APPLN. TYPE	SMALL ENTITY	ISSUE FEE	PUBLICATION FEE	TOTAL FEE(S) DUE	DATE DUE
nonprovisional	NO	<del>425</del> \$80	\$0	<del>425</del> \$80	02/17/2005

EXAMINER	ART UNIT	CLASS-SUBCLASS
NUNN, FREDAS	2911	D14-341000

1. Change of correspondence address or indication of "Fee Address" (37 CFR 1.363).  
 Change of correspondence address (or Change of Correspondence Address form PTO/SB/122) attached.  
 "Fee Address" indication (or "Fee Address" Indication form PTO/SB/47; Rev 03-02 or more recent) attached. Use of a Customer Number is required.
2. For printing on the patent front page, list  
 (1) the names of up to 3 registered patent attorneys or agents OR, alternatively, Beyer Weaver & Thomas, LLP  
 (2) the name of a single firm (having as a member a registered attorney or agent) and the names of up to 2 registered patent attorneys or agents. If no name is listed, no name will be printed.  
 3 \_\_\_\_\_

3. ASSIGNEE NAME AND RESIDENCE DATA TO BE PRINTED ON THE PATENT (print or type)  
 PLEASE NOTE: Unless an assignee is identified below, no assignee data will appear on the patent. If an assignee is identified below, the document has been filed for recordation as set forth in 37 CFR 3.11. Completion of this form is NOT a substitute for filing an assignment.

(A) NAME OF ASSIGNEE: Apple Computer, Inc.  
 (B) RESIDENCE: (CITY and STATE OR COUNTRY): Cupertino, CA

Please check the appropriate assignee category or categories (will not be printed on the patent):  Individual  Corporation or other private group entity  Government

- 4a. The following fee(s) are enclosed:  
 Issue Fee  
 Publication Fee (No small entity discount permitted)  
 Advance Order - # of Copies 12
- 4b. Payment of Fee(s):  
 A check in the amount of the fee(s) is enclosed.  
 Payment by credit card. Form PTO-2038 is attached.  
 The Director is hereby authorized by charge the required fee(s), or credit any overpayment, to Deposit Account Number 500388 (enclose an extra copy of this form).

5. Change in Entity Status (from status indicated above)  
 a. Applicant claims SMALL ENTITY status. See 37 CFR 1.27.  b. Applicant is no longer claiming SMALL ENTITY status. See 37 CFR 1.27(g)(2).

The Director of the USPTO is requested to apply the Issue Fee and Publication Fee (if any) or to re-apply any previously paid issue fee to the application identified above. NOTE: The Issue Fee and Publication Fee (if required) will not be accepted from anyone other than the applicant; a registered attorney or agent; or the assignee or other party in interest as shown by the records of the United States Patent and Trademark Office.

Authorized Signature: Quin C. Hoellwarth Date: 2/11/05  
 Typed or printed name: Quin C. Hoellwarth Registration No.: 45,738

This collection of information is required by 37 CFR 1.311. The information is required to obtain or retain a benefit by the public which is to file (and by the USPTO to process) an application. Confidentiality is governed by 35 U.S.C. 122 and 37 CFR 1.14. This collection is estimated to take 12 minutes to complete, including gathering, preparing, and submitting the completed application form to the USPTO. Time will vary depending upon the individual case. Any comments on the amount of time you require to complete this form and/or suggestions for reducing this burden, should be sent to the Chief Information Officer, U.S. Patent and Trademark Office, U.S. Department of Commerce, P.O. Box 1450, Alexandria, Virginia 22313-1450. DO NOT SEND FEES OR COMPLETED FORMS TO THIS ADDRESS. SEND TO: Commissioner for Patents, P.O. Box 1450, Alexandria, Virginia 22313-1450.

Under the Paperwork Reduction Act of 1995, no persons are required to respond to a collection of information unless it displays a valid OMB control number.

# ARTIFACT SHEET

Enter artifact number below. Artifact number is application number + artifact type code (see list below) + sequential letter (A, B, C ...). The first artifact folder for an artifact type receives the letter A, the second B, etc..  
Examples: 59123456PA, 59123456PB, 59123456ZA, 59123456ZB

29,201,636CA

Indicate quantity of a single type of artifact received but not scanned. Create individual artifact folder/box and artifact number for each Artifact Type.

- CD(s) containing:
- computer program listing  
Doc Code: Computer      Artifact Type Code: P
  - pages of specification  
and/or sequence listing  
and/or table  
Doc Code: Artifact      Artifact Type Code: S
  - content unspecified or combined  
Doc Code: Artifact      Artifact Type Code: U

- 4 Stapled Set(s) Color Documents or B/W Photographs  
Doc Code: Artifact      Artifact Type Code: C

- Microfilm(s)  
Doc Code: Artifact      Artifact Type Code: F

- Video tape(s)  
Doc Code: Artifact      Artifact Type Code: V

- Model(s)  
Doc Code: Artifact      Artifact Type Code: M

- Bound Document(s)  
Doc Code: Artifact      Artifact Type Code: B

- Confidential Information Disclosure Statement or Other Documents marked Proprietary, Trade Secrets, Subject to Protective Order, Material Submitted under MPEP 724.02, etc.  
Doc Code: Artifact      Artifact Type Code X

- Other, description: \_\_\_\_\_  
Doc Code: Artifact      Artifact Type Code: Z

March 8, 2004



UNITED STATES PATENT AND TRADEMARK OFFICE

W

UNITED STATES DEPARTMENT OF COMMERCE  
United States Patent and Trademark Office  
Address: COMMISSIONER FOR PATENTS  
P.O. Box 1450  
Alexandria, Virginia 22313-1450  
www.uspto.gov

APPLICATION NO.	FILING DATE	FIRST NAMED INVENTOR	ATTORNEY DOCKET NO.	CONFIRMATION NO.
-----------------	-------------	----------------------	---------------------	------------------

29/201,636	03/17/2004	Bartley K. Andre	APL1D297	6966
------------	------------	------------------	----------	------

22434 7590 05/06/2005

BEYER WEAVER & THOMAS LLP  
P.O. BOX 70250  
OAKLAND, CA 94612-0250

EXAMINER
----------

NUNN, FREDA S

ART UNIT	PAPER NUMBER
----------	--------------

2911

DATE MAILED: 05/06/2005

Please find below and/or attached an Office communication concerning this application or proceeding.



**Supplemental  
Notice of Allowability**

Application No.

29/201,636

Examiner

Freda S. Nunn

Applicant(s)

ANDRE ET AL.

Art Unit

2911

**-- The MAILING DATE of this communication appears on the cover sheet with the correspondence address--**

All claims being allowable, PROSECUTION ON THE MERITS IS (OR REMAINS) CLOSED in this application. If not included herewith (or previously mailed), a Notice of Allowance (PTOL-85) or other appropriate communication will be mailed in due course. **THIS NOTICE OF ALLOWABILITY IS NOT A GRANT OF PATENT RIGHTS.** This application is subject to withdrawal from issue at the initiative of the Office or upon petition by the applicant. See 37 CFR 1.313 and MPEP 1308.

1.  This communication is responsive to the eIDS filed September 8, 2004.
2.  The allowed claim(s) is/are 1.
3.  The drawings filed on \_\_\_\_\_ are accepted by the Examiner.
4.  Acknowledgment is made of a claim for foreign priority under 35 U.S.C. § 119(a)-(d) or (f).
  - a)  All   b)  Some\*   c)  None   of the:
    1.  Certified copies of the priority documents have been received.
    2.  Certified copies of the priority documents have been received in Application No. \_\_\_\_\_.
    3.  Copies of the certified copies of the priority documents have been received in this national stage application from the International Bureau (PCT Rule 17.2(a)).

\* Certified copies not received: \_\_\_\_\_.

Applicant has THREE MONTHS FROM THE "MAILING DATE" of this communication to file a reply complying with the requirements noted below. Failure to timely comply will result in ABANDONMENT of this application.  
**THIS THREE-MONTH PERIOD IS NOT EXTENDABLE.**

5.  A SUBSTITUTE OATH OR DECLARATION must be submitted. Note the attached EXAMINER'S AMENDMENT or NOTICE OF INFORMAL PATENT APPLICATION (PTO-152) which gives reason(s) why the oath or declaration is deficient.
  6.  CORRECTED DRAWINGS ( as "replacement sheets") must be submitted.
    - (a)  including changes required by the Notice of Draftsperson's Patent Drawing Review ( PTO-948) attached
      - 1)  hereto or 2)  to Paper No./Mail Date \_\_\_\_\_.
    - (b)  including changes required by the attached Examiner's Amendment / Comment or in the Office action of Paper No./Mail Date \_\_\_\_\_.
- Identifying indicia such as the application number (see 37 CFR 1.84(c)) should be written on the drawings in the front (not the back) of each sheet. Replacement sheet(s) should be labeled as such in the header according to 37 CFR 1.121(d).**
7.  DEPOSIT OF and/or INFORMATION about the deposit of BIOLOGICAL MATERIAL must be submitted. Note the attached Examiner's comment regarding REQUIREMENT FOR THE DEPOSIT OF BIOLOGICAL MATERIAL.

**Attachment(s)**

1.  Notice of References Cited (PTO-892)
2.  Notice of Draftsperson's Patent Drawing Review (PTO-948)
3.  Information Disclosure Statements (PTO-1449 or PTO/SB/08),  
Paper No./Mail Date September 8, 2004
4.  Examiner's Comment Regarding Requirement for Deposit  
of Biological Material
5.  Notice of Informal Patent Application (PTO-152)
6.  Interview Summary (PTO-413),  
Paper No./Mail Date \_\_\_\_\_
7.  Examiner's Amendment/Comment
8.  Examiner's Statement of Reasons for Allowance
9.  Other \_\_\_\_\_

  
Freda S. Nunn  
Primary Examiner  
Art Unit 2911

**ELECTRONIC INFORMATION DISCLOSURE STATEMENT**

Electronic Version v18  
 Stylesheet Version v18.0

<b>Title of Invention</b>	<b>ELECTRONIC DEVICE</b>
---------------------------	--------------------------

Application Number : 29/201636 

Confirmation Number: 6966

First Named Applicant: Bartley Andre

Attorney Docket Number: APL1D297

Art Unit: 2911

Examiner: Freda S. Nunn

Search string: ( 4976435 or 5192082 or 5661632 or 5964661 or 6254477 or D183809 or D264969 or D349923 or D359306 or D362272 or D362461 or D378686 or D385299 or D386521 or D399526 or D402310 or D410028 or D412940 or D425558 or D430117 or D430169 or D437860 or D445787 or D448810 or D449606 or D491933 or D450713 or D452250 or D469109 or D472245 or D481036 or D481718 or D486823 or D487457 or D487742 or D489717 or D490420 or D491936 or D494164 ).pn

**US Patent Documents**

**Note: Applicant is not required to submit a paper copy of cited US Patent Documents**

init	Cite.No.	Patent No.	Date	Patentee	Kind	Class	Subclass
<del>6N</del>	1	4976435	1990-12-11	Shatford et al.			
	2	5192082	1993-03-09	Inoue et al.			
	3	5661632	1997-08-26	Register			
	4	5964661	1999-10-12	Dodge			
	5	6254477	2001-07-03	Sasaki			
	6	D183809	2003-12-16	Lim			
	7	D264969	1982-06-15	McGourty			
	8	D349923	1994-08-23	Billings et al.			
	9	D359306	1995-06-13	Lande et al.			
	10	D362272	1995-09-12	Luong			
	11	D362461	1995-08-19	Luong			
	12	D378686	1997-04-01	Proctor et al.			
	13	D385299	1997-10-21	Adams			
	14	D386521	1997-11-18	Eisenbaum			
	15	D399526	1998-10-13	Brady			
	16	D402310	1998-12-08	Hendricks			
<input checked="" type="checkbox"/>	17	D410028	1999-05-18	Fyffe			
<input checked="" type="checkbox"/>	18	D412940	1999-08-07	Kato et al.			
<input checked="" type="checkbox"/>	19	D425558	2000-05-23	Tarpenning			

FBN	20	D430117	2000-08-29	Sachs et al.						
	21	D430169	2000-08-29	Scibora						
	22	D437860	2001-02-20	Suzuki						
	23	D445787	2001-07-31	Francis						
	24	D448810	2001-10-02	Goto						
	25	D449606	2001-10-23	Lee et al.						
	26	D491933	2004-06-22	Guo						
	27	D450713	2001-11-20	Masamitsu et al.						
	28	D452250	2001-12-18	Chan						
	29	D469109	2003-01-21	Andre						
	30	D472245	2003-03-25	Andre et al.						
	31	D481036	2003-10-21	Wentt						
	32	D481718	2003-11-04	Chiang et al.						
	33	D486823	2004-02-17	Kuo						
	34	D487457	2004-03-09	Liu						
	35	D487742	2004-03-23	Huang et al.						
	36	D489717	2004-05-11	Hsien						
✓	37	D490420	2004-05-25	Solomon						
✓	38	D491936	2004-06-22	Jao						
FBN	39	D494164	2004-08-10	Wu et al.						

**Signature**

Examiner Name	Date
Freda S. Nunn	5/2/05



Robert Greene Sterne  
 Jorge A. Goldstein  
 David K.S. Cornwell  
 Robert W. Esmond  
 Tracy-Gene G. Durkin  
 Michele A. Cimballa  
 Michael B. Ray  
 Robert E. Sokohl  
 Eric K. Steffe  
 Michael Q. Lee  
 John M. Covert  
 Robert C. Millonig  
 Donald J. Featherstone  
 Timothy J. Shea, Jr  
 Michael V. Messinger  
 Judith U. Kim  
 Jeffrey T. Helvey  
 Eldora L. Ellison

Donald R. Banowit  
 Peter A. Jackman  
 Brian J. Del Buono  
 Mark Fox Evens  
 Vincent L. Capuano  
 Elizabeth J. Haanes  
 Michael D. Specht  
 Kevin W. McCabe  
 Glenn J. Perry  
 Edward W. Yee  
 Grant E. Reed  
 Virgil Lee Beaston  
 Theodore A. Wood  
 Joseph S. Ostroff  
 Jason D. Eisenberg  
 Tracy L. Muller  
 Jon E. Wright  
 LuAnne M. DeSantis

Ann E. Summerfield  
 Helene C. Carlson  
 Cynthia M. Bouchez  
 Timothy A. Doyle  
 Gaby L. Longworth  
 Lori A. Gordon  
 Laura A. Vogel  
 Bashir M.S. Ali  
 Shannon A. Carroll  
 Anbar F. Khal  
 Michelle K. Holoubek  
 Marsha A. Rose  
 Scott A. Schaller  
 Lei Zhou  
 W. Blake Coblentz  
 James J. Pohl  
 John T. Haran  
 Mark W. Rygiel

Michael R. Malek\*  
 Carla Ji-Eun Kim  
 Doyle A. Siever\*  
 Ulrike Winkler Jenks  
 Paul A. Calvo  
 Robert A. Schwartzman  
 C. Matthew Rozier\*  
 Shameek Ghose  
 Randall K. Baldwin  
 Daniel J. Nevriy  
 Registered Patent Agents\*  
 Karen R. Markowicz  
 Matthew J. Dowd  
 Mita Mukherjee  
 Scott M. Woodhouse  
 Peter A. Socarras  
 Jeffrey K. Mills

Danielle L. Letting  
 Lori Brandes  
 Steven C. Oppenheimer  
 Aaron S. Lukas  
 Gaurav Asthana  
 Robert E. Bakin  
 Salvador M. Bezos  
 Of Counsel  
 Edward J. Kessler  
 Kenneth C. Bass III  
 Marvin C. Guthrie  
 Christopher P. Wrist  
 \*Admitted only in Maryland  
 \*Admitted only in Virginia  
 \*Practice Limited to  
 Federal Agencies

January 31, 2008

WRITER'S DIRECT NUMBER:  
 (202) 772-8660  
 INTERNET ADDRESS:  
 TDURKIN@SKGF.COM

Commissioner for Patents  
 PO Box 1450  
 Alexandria, VA 22313-1450

Attn: Mail Stop Post Issue

Re: U.S. Design Patent Application  
 Patent No. D503,532; Issued: April 5, 2005  
 For: Electronic Device Holder  
 Inventors: ANDRE *et al.*  
 Our Ref: 2607.1200000(P3244US1)/TGD

Sir:

Transmitted herewith for appropriate action are the following documents:

1. Power of Attorney to Prosecute Applications Before the USPTO;
2. Statement Under 37 C.F.R. § 3.73(b); and
3. Change of Correspondence Address.

The above-listed documents are filed electronically through EFS-Web.

In the event that extensions of time are necessary to prevent abandonment of this patent application, then such extensions of time are hereby petitioned.

The U.S. Patent and Trademark Office is hereby authorized to charge any fee deficiency, or credit any overpayment, to our Deposit Account No. 19-0036.

Respectfully submitted,

STERNE, KESSLER, GOLDSTEIN & FOX P.L.L.C.

Tracy-Gene G. Durkin  
 Attorney for Applicants  
 Registration No. 32,831

TGD/AKS:ecw  
 Enclosures

Sterne, Kessler, Goldstein & Fox P.L.L.C. : 1100 New York Avenue, NW : Washington, DC 20005 : 202.371.2600 f 202.371.2540 : www.skgf.com

775798\_1.DOC

## Electronic Acknowledgement Receipt

<b>EFS ID:</b>	2797705
<b>Application Number:</b>	29201636
<b>International Application Number:</b>	
<b>Confirmation Number:</b>	6966
<b>Title of Invention:</b>	ELECTRONIC DEVICE
<b>First Named Inventor/Applicant Name:</b>	Bartley K. Andre
<b>Customer Number:</b>	22434
<b>Filer:</b>	Tracy-Gene G. Durkin/Erin Wong
<b>Filer Authorized By:</b>	Tracy-Gene G. Durkin
<b>Attorney Docket Number:</b>	APL1D297
<b>Receipt Date:</b>	31-JAN-2008
<b>Filing Date:</b>	17-MAR-2004
<b>Time Stamp:</b>	18:27:19
<b>Application Type:</b>	Design

### Payment information:

Submitted with Payment	no
------------------------	----

### File Listing:

Document Number	Document Description	File Name	File Size(Bytes) /Message Digest	Multi Part /.zip	Pages (if appl.)
1		1200000.pdf	201138 9490a7e6c729e15c7a075fb228370ac7d0e7c99e	yes	4

<b>Multipart Description/PDF files in .zip description</b>			
<b>Document Description</b>		<b>Start</b>	<b>End</b>
Miscellaneous Incoming Letter		1	1
Power of Attorney		2	2
Assignee showing of ownership per 37 CFR 3.73(b).		3	3
Change of Address		4	4

**Warnings:**

**Information:**

**Total Files Size (in bytes):**

201138

**This Acknowledgement Receipt evidences receipt on the noted date by the USPTO of the indicated documents, characterized by the applicant, and including page counts, where applicable. It serves as evidence of receipt similar to a Post Card, as described in MPEP 503.**

**New Applications Under 35 U.S.C. 111**

**If a new application is being filed and the application includes the necessary components for a filing date (see 37 CFR 1.53(b)-(d) and MPEP 506), a Filing Receipt (37 CFR 1.54) will be issued in due course and the date shown on this Acknowledgement Receipt will establish the filing date of the application.**

**National Stage of an International Application under 35 U.S.C. 371**

**If a timely submission to enter the national stage of an international application is compliant with the conditions of 35 U.S.C. 371 and other applicable requirements a Form PCT/DO/EO/903 indicating acceptance of the application as a national stage submission under 35 U.S.C. 371 will be issued in addition to the Filing Receipt, in due course.**

**New International Application Filed with the USPTO as a Receiving Office**

**If a new international application is being filed and the international application includes the necessary components for an international filing date (see PCT Article 11 and MPEP 1810), a Notification of the International Application Number and of the International Filing Date (Form PCT/RO/105) will be issued in due course, subject to prescriptions concerning national security, and the date shown on this Acknowledgement Receipt will establish the international filing date of the application.**

Under the Paperwork Reduction Act of 1995, no persons are required to respond to a collection of information unless it displays a valid OMB control number.

<b>CHANGE OF CORRESPONDENCE ADDRESS</b> <i>Patent</i>	Patent Number	D503,532
	Issue Date	April 5, 2005
	Application Number	29/196,833
	Filing Date	January 5, 2004
	First Named Inventor	Bartley K. ANDRE
	Attorney Docket Number	2607.1200000
Address to: Mail Stop Post Issue Commissioner for Patents P.O. Box 1450 Alexandria, VA 22313-1450		

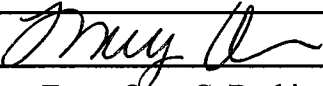
Please change the Correspondence Address for the above-identified patent to:		
<input checked="" type="checkbox"/>	The address associated with Customer Number:	63975
<b>OR</b>		
<input type="checkbox"/>	<b>Firm or Individual Name</b>	
<b>Address</b>		
<b>City</b>	<b>State</b>	<b>ZIP</b>
<b>Country</b>		
<b>Telephone</b>	<b>Email</b>	
This form cannot be used to change the data associated with a Customer Number. To change the data associated with an existing Customer Number use "Request for Customer Number Data Change" (PTO/SB/124).		
This form will not affect any "fee address" provided for the above-identified patent. To change a "fee address" use the "Fee Address Indication Form" (PTO/SB/47).		
I am the:		
<input type="checkbox"/>	Patentee.	
<input type="checkbox"/>	Assignee of record of the entire interest. See 37 CFR 3.71. Statement under 37 CFR 3.73(b) is enclosed. (Form PTO/SB/96).	
<input checked="" type="checkbox"/>	Attorney or agent of record. Registration Number <u>32,831</u>	
Signature		
Typed or Printed Name	Tracy-Gene G. Durkin	
Date	January 31, 2008	Telephone (202) 371-2600
NOTE: Signatures of all the inventors or assignees of record of the entire interest or their representative(s) are required. Submit multiple forms if more than one signature is required, see below*.		
<input checked="" type="checkbox"/>	*Total of <u>1</u> forms are submitted.	

This collection of information is required by 37 CFR 1.33. The information is required to obtain or retain a benefit by the public which is to file (and by the USPTO to process) an application. Confidentiality is governed by 35 U.S.C. 122 and 37 CFR 1.11 and 1.14. This collection is estimated to take 3 minutes to complete, including gathering, preparing, and submitting the completed application form to the USPTO. Time will vary depending upon the individual case. Any comments on the amount of time you require to complete this form and/or suggestions for reducing this burden, should be sent to the Chief Information Officer, U.S. Patent and Trademark Office, U.S. Department of Commerce, P.O. Box 1450, Alexandria, VA 22313-1450. DO NOT SEND FEES OR COMPLETED FORMS TO THIS ADDRESS. **SEND TO: Mail Stop Post Issue, Commissioner for Patents, P.O. Box 1450, Alexandria, VA 22313-1450.**

If you need assistance in completing the form, call 1-800-PTO-9199 and select option 2.

**STATEMENT UNDER 37 CFR 3.73(b)**

2607.120000(P3244US1)/TGD

Applicant/Patent Owner: ANDRE et al.Application No./Patent No.: D503,532 Filed/Issue Date: April 5, 2005Entitled: Electronic Device Holder

Apple Inc., a corporation  
 (Name of Assignee) (Type of Assignee, e.g., corporation, partnership, university, government agency, etc.)

states that it is:

1.  the assignee of the entire right, title, and interest; or  
 2.  an assignee of less than the entire right, title and interest  
 (The extent (by percentage) of its ownership interest is \_\_\_\_\_%)

in the patent application/patent identified above by virtue of either:

A.  An assignment from the inventor(s) of the patent application/patent identified above. The assignment was recorded in the United States Patent and Trademark Office at Reel \_\_\_\_\_, Frame \_\_\_\_\_, or for which a copy thereof is attached.

**OR**

B.  A chain of title from the inventor(s), of the patent application/patent identified above, to the current assignee as follows:

1. From: Andre et al. To: Apple Computer, Inc.  
 The document was recorded in the United States Patent and Trademark Office at  
 Reel 014496, Frame 0262, or for which a copy thereof is attached.
2. From: Apple Computer, Inc. To: Apple Inc.  
 The document was recorded in the United States Patent and Trademark Office at  
 Reel 019000, Frame 0383, or for which a copy thereof is attached.
3. From: \_\_\_\_\_ To: \_\_\_\_\_  
 The document was recorded in the United States Patent and Trademark Office at  
 Reel \_\_\_\_\_, Frame \_\_\_\_\_, or for which a copy thereof is attached.

Additional documents in the chain of title are listed on a supplemental sheet.

As required by 37 CFR 3.73(b)(1)(i), the documentary evidence of the chain of title from the original owner to the assignee was, or concurrently is being, submitted for recordation pursuant to 37 CFR 3.11.

[NOTE: A separate copy (i.e., a true copy of the original assignment document(s)) must be submitted to Assignment Division in accordance with 37 CFR Part 3, to record the assignment in the records of the USPTO. See MPEP 302.08]

The undersigned (whose title is supplied below) is authorized to act on behalf of the assignee.

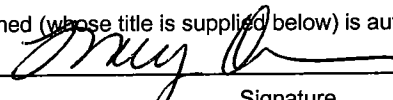
 1/31/08  
 Signature Date  
Tracy-Gene G. Durkin, Reg. No. 32,831 202-371-2600  
 Printed or Typed Name Telephone Number  
Patent Attorney  
 Title

This collection of information is required by 37 CFR 3.73(b). The information is required to obtain or retain a benefit by the public which is to file (and by the USPTO to process) an application. Confidentiality is governed by 35 U.S.C. 122 and 37 CFR 1.11 and 1.14. This collection is estimated to take 12 minutes to complete, including gathering, preparing, and submitting the completed application form to the USPTO. Time will vary depending upon the individual case. Any comments on the amount of time you require to complete this form and/or suggestions for reducing this burden, should be sent to the Chief Information Officer, U.S. Patent and Trademark Office, U.S. Department of Commerce, P.O. Box 1450, Alexandria, VA 22313-1450. DO NOT SEND FEES OR COMPLETED FORMS TO THIS ADDRESS. SEND TO: Commissioner for Patents, P.O. Box 1450, Alexandria, VA 22313-1450.

If you need assistance in completing the form, call 1-800-PTO-9199 and select option 2.



Under the Paperwork Reduction Act of 1995, no persons are required to respond to a collection of information unless it displays a valid OMB control number.

**POWER OF ATTORNEY TO PROSECUTE APPLICATIONS BEFORE THE USPTO**

I hereby revoke all previous powers of attorney given in the application identified in the attached statement under 37 CFR 3.73(b).

I hereby appoint:

 Practitioners associated with the Customer Number:

63975

OR

 Practitioner(s) named below (if more than ten patent practitioners are to be named, then a customer number must be used):

Name	Registration Number	Name	Registration Number

as attorney(s) or agent(s) to represent the undersigned before the United States Patent and Trademark Office (USPTO) in connection with any and all patent applications assigned only to the undersigned according to the USPTO assignment records or assignment documents attached to this form in accordance with 37 CFR 3.73(b).

Please change the correspondence address for the application identified in the attached statement under 37 CFR 3.73(b) to:

 The address associated with Customer Number:

63975

OR

<input type="checkbox"/> Firm or Individual Name			
Address			
City	State	Zip	
Country			
Telephone	Email		

Assignee Name and Address:

Apple Inc.  
1 Infinite Loop  
Cupertino, CA 95014

**A copy of this form, together with a statement under 37 CFR 3.73(b) (Form PTO/SB/96 or equivalent) is required to be filed in each application in which this form is used. The statement under 37 CFR 3.73(b) may be completed by one of the practitioners appointed in this form if the appointed practitioner is authorized to act on behalf of the assignee, and must identify the application in which this Power of Attorney is to be filed.**

**SIGNATURE of Assignee of Record**

The individual whose signature and title is supplied below is authorized to act on behalf of the assignee

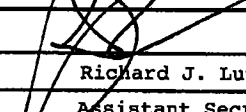
Signature		Date	May 14, 2007
Name	Richard J. Lutton	Telephone	(408) 974-9453
Title	Assistant Secretary and Chief Patent Counsel		

This collection of information is required by 37 CFR 1.31, 1.32 and 1.33. The information is required to obtain or retain a benefit by the public which is to file (and by the USPTO to process) an application. Confidentiality is governed by 35 U.S.C. 122 and 37 CFR 1.11 and 1.14. This collection is estimated to take 3 minutes to complete, including gathering, preparing, and submitting the completed application form to the USPTO. Time will vary depending upon the individual case. Any comments on the amount of time you require to complete this form and/or suggestions for reducing this burden, should be sent to the Chief Information Officer, U.S. Patent and Trademark Office, U.S. Department of Commerce, P.O. Box 1450, Alexandria, VA 22313-1450. DO NOT SEND FEES OR COMPLETED FORMS TO THIS ADDRESS. **SEND TO: Commissioner for Patents, P.O. Box 1450, Alexandria, VA 22313-1450.**

If you need assistance in completing the form, call 1-800-PTO-9199 and select option 2.



**Sterne Kessler  
Goldstein Fox**  
ATTORNEYS AT LAW

Robert Greene Sterne  
Jorge A. Goldstein  
David K.S. Cornwell  
Robert W. Esmond  
Tracy-Gene G. Durkin  
Michele A. Cimbala  
Michael B. Ray  
Robert E. Sokohl  
Eric K. Steffe  
Michael Q. Lee  
John M. Covert  
Robert C. Millanig  
Donald J. Featherstone  
Timothy J. Shea, Jr.  
Michael V. Messinger  
Judith U. Kim  
Mark Fox Evens  
Jeffrey T. Helvey  
Eldora L. Ellison  
Donald R. Banowitz  
Peter A. Jackman  
Brian J. Del Buono

Elizabeth J. Haanes  
Michael D. Spacht  
Kevin W. McCabe  
Glenn J. Perry  
Theodore A. Wood  
Gaby L. Longworth  
Edward W. Yee  
Grant E. Reed  
Tracy L. Muller  
Jon E. Wright  
LuAnne M. DeSantis  
Helene C. Carlson  
Cynthia M. Bouchez  
Timothy A. Doyle  
Lori A. Gordon  
Shannon A. Carroll  
Anbar F. Khal  
Michelle K. Holoubek  
Marsha A. Rose  
Scott A. Schaller  
Lei Zhou  
W. Blake Coblenz

James J. Pohl  
John T. Haran  
Mark W. Rygiel  
Michael R. Malek  
Carla Ji-Eun Kim  
Doyle A. Siever\*  
Ulrike Winkler Jenks  
Paul A. Calvo  
C. Matthew Rozier  
Randall K. Baldwin  
Lori M. Brandes  
Deborah A. Sterling  
Jeremy M. Klass  
Stephanie L. Elmer  
Jeffrey K. Mills  
Mita Mukherjee\*  
Scott M. Woodhouse\*  
Peter A. Socarras  
Christian A. Camarce  
Richard D. Collier  
Patrick P. Hansen  
Ross G. Hicks

Keisha Hylton-Rodic  
Bonnie Nannenga-Combs  
Alyssa K. Sandrowitz  
Jonathan M. Strang  
Ishan P. Weerakoon  
Chenghua Luo  
Salvador M. Bezos\*  
Bruce B. Vance  
Justin T. Slier  
Byron L. Pickard  
Kellie K. DiNapoli\*  
Richard B. Almon\*\*  
Christopher B. Ferenc\*  
Jeffrey R. Fougere\*  
William P. Ladd\*

Registered Patent Agents\*  
Karen R. Markowicz  
Danielle L. Letting  
Steven C. Oppenheimer  
Aaron S. Lukas

Jonathan Tuminaro  
Gaurav Asthana  
Yasser Mourtada  
Cynthia L. DeRenzo  
Omar F. Amin  
R. Wilson Powers III  
Erin C. Wong  
Joseph E. Mutschelknaus  
Kavon Nasabzadeh  
Aaron S. Ward

Of Counsel  
Edward J. Kessler  
Kenneth C. Bass III  
Christopher P. Wrist  
David C. Isaacson  
Jason D. Eisenberg

\*Admitted only in Maryland  
\*Admitted only in Virginia  
\*\*Practice Limited to  
Federal Agencies

August 5, 2009

WRITER'S DIRECT NUMBER:  
(202) 772-8660  
INTERNET ADDRESS:  
TDURKIN@SKGF.COM

Commissioner for Patents  
PO Box 1450  
Alexandria, VA 22313-1450

**Attn: Mail Stop Post Issue**

Re: U.S. Design Patent  
Patent No. D504,889; Issued: May 10, 2005  
For: Electronic Device  
Inventors: ANDRE *et al.*  
Our Ref: 2607.1220000(P3297US1)/TGD

Sir:

Transmitted herewith for appropriate action are the following documents:

1. Power of Attorney to Prosecute Applications Before the USPTO;
2. Statement Under 37 C.F.R. § 3.73(b); and
3. Change of Correspondence Address.

The above-listed documents are filed electronically through EFS-Web.

In the event that extensions of time are necessary to prevent abandonment of this patent application, then such extensions of time are hereby petitioned.

The U.S. Patent and Trademark Office is hereby authorized to charge any fee deficiency, or credit any overpayment, to our Deposit Account No. 19-0036.

Respectfully submitted,

STERNE, KESSLER, GOLDSTEIN & FOX P.L.L.C.

Tracy-Gene G. Durkin  
Attorney for Applicants  
Registration No. 32,831

TGD/tts  
Enclosures

Sterne, Kessler, Goldstein & Fox P.L.L.C. : 1100 New York Avenue, NW : Washington, DC 20005 : 202.371.2600 f 202.371.2540 : www.skgsf.com

APLNDC00032459

**POWER OF ATTORNEY TO PROSECUTE APPLICATIONS BEFORE THE USPTO**

I hereby revoke all previous powers of attorney given in the application identified in the attached statement under 37 CFR 3.73(b).

I hereby appoint:

Practitioners associated with the Customer Number: 63975

**OR**  
 Practitioner(s) named below (if more than ten patent practitioners are to be named, then a customer number must be used):

Name	Registration Number		Name	Registration Number

as attorney(s) or agent(s) to represent the undersigned before the United States Patent and Trademark Office (USPTO) in connection with any and all patent applications assigned only to the undersigned according to the USPTO assignment records or assignment documents attached to this form in accordance with 37 CFR 3.73(b).

Please change the correspondence address for the application identified in the attached statement under 37 CFR 3.73(b) to:

The address associated with Customer Number: 63975

**OR**

<input type="checkbox"/> Firm or Individual Name			
Address			
City	State	Zip	
Country			
Telephone			Email

Assignee Name and Address:

Apple Inc.  
1 Infinite Loop  
Cupertino, CA 95014

**A copy of this form, together with a statement under 37 CFR 3.73(b) (Form PTO/SB/86 or equivalent) is required to be filed in each application in which this form is used. The statement under 37 CFR 3.73(b) may be completed by one of the practitioners appointed in this form if the appointed practitioner is authorized to act on behalf of the assignee, and must identify the application in which this Power of Attorney is to be filed.**

**SIGNATURE of Assignee of Record**  
The individual whose signature and title is supplied below is authorized to act on behalf of the assignee

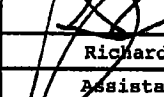
Signature		Date	May 14, 2007
Name	Richard J. Lutton	Telephone	(408) 974-9453
Title	Assistant Secretary and Chief Patent Counsel		

This collection of information is required by 37 CFR 1.31, 1.32 and 1.33. The information is required to obtain or retain a benefit by the public which is to file (and by the USPTO to process) an application. Confidentiality is governed by 35 U.S.C. 122 and 37 CFR 1.11 and 1.14. This collection is estimated to take 3 minutes to complete, including gathering, preparing, and submitting the completed application form to the USPTO. Time will vary depending upon the individual case. Any comments on the amount of time you require to complete this form and/or suggestions for reducing this burden, should be sent to the Chief Information Officer, U.S. Patent and Trademark Office, U.S. Department of Commerce, P.O. Box 1450, Alexandria, VA 22313-1450. DO NOT SEND FEES OR COMPLETED FORMS TO THIS ADDRESS. SEND TO: Commissioner for Patents, P.O. Box 1450, Alexandria, VA 22313-1450.

*If you need assistance in completing the form, call 1-800-PTO-9199 and select option 2.*

## Electronic Acknowledgement Receipt

<b>EFS ID:</b>	5833242
<b>Application Number:</b>	29201636
<b>International Application Number:</b>	
<b>Confirmation Number:</b>	6966
<b>Title of Invention:</b>	ELECTRONIC DEVICE
<b>First Named Inventor/Applicant Name:</b>	Bartley K. Andre
<b>Customer Number:</b>	22434
<b>Filer:</b>	Tracy-Gene G. Durkin/Terriel Spruill
<b>Filer Authorized By:</b>	Tracy-Gene G. Durkin
<b>Attorney Docket Number:</b>	APL1D297
<b>Receipt Date:</b>	05-AUG-2009
<b>Filing Date:</b>	17-MAR-2004
<b>Time Stamp:</b>	15:11:55
<b>Application Type:</b>	Design

### Payment information:

Submitted with Payment	no
------------------------	----

### File Listing:

Document Number	Document Description	File Name	File Size(Bytes)/ Message Digest	Multi Part /.zip	Pages (if appl.)
1		2607122POA.pdf	235700 <small>3bdaba81545f023504e9647cfc1ae9d358449f33</small>	yes	4

<b>Multipart Description/PDF files in .zip description</b>		
<b>Document Description</b>	<b>Start</b>	<b>End</b>
Miscellaneous Incoming Letter	1	1
Power of Attorney	2	2
Assignee showing of ownership per 37 CFR 3.73(b).	3	3
Change of Address	4	4

**Warnings:**

**Information:**

<b>Total Files Size (in bytes):</b>	235700
-------------------------------------	--------

**This Acknowledgement Receipt evidences receipt on the noted date by the USPTO of the indicated documents, characterized by the applicant, and including page counts, where applicable. It serves as evidence of receipt similar to a Post Card, as described in MPEP 503.**

**New Applications Under 35 U.S.C. 111**

**If a new application is being filed and the application includes the necessary components for a filing date (see 37 CFR 1.53(b)-(d) and MPEP 506), a Filing Receipt (37 CFR 1.54) will be issued in due course and the date shown on this Acknowledgement Receipt will establish the filing date of the application.**

**National Stage of an International Application under 35 U.S.C. 371**

**If a timely submission to enter the national stage of an international application is compliant with the conditions of 35 U.S.C. 371 and other applicable requirements a Form PCT/DO/EO/903 indicating acceptance of the application as a national stage submission under 35 U.S.C. 371 will be issued in addition to the Filing Receipt, in due course.**

**New International Application Filed with the USPTO as a Receiving Office**

**If a new international application is being filed and the international application includes the necessary components for an international filing date (see PCT Article 11 and MPEP 1810), a Notification of the International Application Number and of the International Filing Date (Form PCT/RO/105) will be issued in due course, subject to prescriptions concerning national security, and the date shown on this Acknowledgement Receipt will establish the international filing date of the application.**

Under the Paperwork Reduction Act of 1995, no persons are required to respond to a collection of information unless it displays a valid OMB control number.

**CHANGE OF  
CORRESPONDENCE ADDRESS  
Patent**Address to:  
Mail Stop Post Issue  
Commissioner for Patents  
P.O. Box 1450  
Alexandria, VA 22313-1450

Patent Number	D504,889
Issue Date	May 10, 2005
Application Number	29/201,636
Filing Date	March 17, 2004
First Named Inventor	Bartley K. ANDRE
Attorney Docket Number	2607.1220000(P3297US1)/TGD

Please change the Correspondence Address for the above-identified patent to:

 The address associated with Customer Number:

63975

OR

 Firm or  
Individual Name**Address**

City

State

ZIP

**Country**

Telephone

Email

This form cannot be used to change the data associated with a Customer Number. To change the data associated with an existing Customer Number use "Request for Customer Number Data Change" (PTO/SB/124).

This form will not affect any "fee address" provided for the above-identified patent. To change a "fee address" use the "Fee Address Indication Form" (PTO/SB/47).

I am the:

- Patentee.
- Assignee of record of the entire interest. See 37 CFR 3.71.  
Statement under 37 CFR 3.73(b) is enclosed. (Form PTO/SB/96).
- Attorney or agent of record. Registration Number 32,831.

Signature

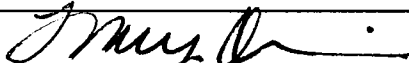
Typed or  
Printed Name

Tracy-Gene G. Durkin

Date

August 5, 2009

Telephone

(202) 371-2600

NOTE: Signatures of all the inventors or assignees of record of the entire interest or their representative(s) are required. Submit multiple forms if more than one signature is required, see below\*.

 \*Total of 1 forms are submitted.This collection of information is required by 37 CFR 1.33. The information is required to obtain or retain a benefit by the public which is to file (and by the USPTO to process) an application. Confidentiality is governed by 35 U.S.C. 122 and 37 CFR 1.11 and 1.14. This collection is estimated to take 3 minutes to complete, including gathering, preparing, and submitting the completed application form to the USPTO. Time will vary depending upon the individual case. Any comments on the amount of time you require to complete this form and/or suggestions for reducing this burden, should be sent to the Chief Information Officer, U.S. Patent and Trademark Office, U.S. Department of Commerce, P.O. Box 1450, Alexandria, VA 22313-1450. DO NOT SEND FEES OR COMPLETED FORMS TO THIS ADDRESS. **SEND TO: Mail Stop Post Issue, Commissioner for Patents, P.O. Box 1450, Alexandria, VA 22313-1450.**

If you need assistance in completing the form, call 1-800-PTO-9199 and select option 2.

Under the Paperwork Reduction Act of 1995, no persons are required to respond to a collection of information unless it displays a valid OMB control number.

**STATEMENT UNDER 37 CFR 3.73(b)**

2607.1220000(P3297US1)/TGD

Applicant/Patent Owner: ANDRE et al.

Application No./Patent No.: D504,889 Filed/Issue Date: May 10, 2005

Titled: Electronic Device

Apple Inc., a corporation  
(Name of Assignee) (Type of Assignee, e.g., corporation, partnership, university, government agency, etc.)

states that it is:

- 1.  the assignee of the entire right, title, and interest in;
- 2.  an assignee of less than the entire right, title, and interest in  
(The extent (by percentage) of its ownership interest is \_\_\_\_\_ %); or
- 3.  the assignee of an undivided interest in the entirety of (a complete assignment from one of the joint inventors was made)

the patent application/patent identified above, by virtue of either:

A.  An assignment from the inventor(s) of the patent application/patent identified above. The assignment was recorded in the United States Patent and Trademark Office at Reel \_\_\_\_\_, Frame \_\_\_\_\_, or for which a copy therefore is attached.

OR

B.  A chain of title from the inventor(s), of the patent application/patent identified above, to the current assignee as follows:

1. From: Andre et al. To: Apple Computer, Inc.

The document was recorded in the United States Patent and Trademark Office at  
Reel 015120, Frame 0170, or for which a copy thereof is attached.

2. From: Andre et al. To: Apple Computer, Inc.

The document was recorded in the United States Patent and Trademark Office at  
Reel 015809, Frame 0070, or for which a copy thereof is attached.

3. From: Apple Computer, Inc. To: Apple Inc.

The document was recorded in the United States Patent and Trademark Office at  
Reel 019000, Frame 0383, or for which a copy thereof is attached.

Additional documents in the chain of title are listed on a supplemental sheet(s).

As required by 37 CFR 3.73(b)(1)(i), the documentary evidence of the chain of title from the original owner to the assignee was, or concurrently is being, submitted for recordation pursuant to 37 CFR 3.11.

[NOTE: A separate copy (i.e., a true copy of the original assignment document(s)) must be submitted to Assignment Division in accordance with 37 CFR Part 3, to record the assignment in the records of the USPTO. See MPEP 302.08]

The undersigned (whose title is supplied below) is authorized to act on behalf of the assignee.

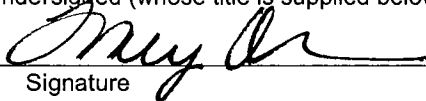

Signature

August 5, 2009

Date

Tracy-Gene G. Durkin, Reg. No. 32,831

Printed or Typed Name

Patent Attorney

Title

This collection of information is required by 37 CFR 3.73(b). The information is required to obtain or retain a benefit by the public which is to file (and by the USPTO to process) an application. Confidentiality is governed by 35 U.S.C. 122 and 37 CFR 1.11 and 1.14. This collection is estimated to take 12 minutes to complete, including gathering, preparing, and submitting the completed application form to the USPTO. Time will vary depending upon the individual case. Any comments on the amount of time you require to complete this form and/or suggestions for reducing this burden, should be sent to the Chief Information Officer, U.S. Patent and Trademark Office, U.S. Department of Commerce, P.O. Box 1450, Alexandria, VA 22313-1450. DO NOT SEND FEES OR COMPLETED FORMS TO THIS ADDRESS. SEND TO: Commissioner for Patents, P.O. Box 1450, Alexandria, VA 22313-1450.



UNITED STATES PATENT AND TRADEMARK OFFICE

UNITED STATES DEPARTMENT OF COMMERCE  
United States Patent and Trademark Office  
Address: COMMISSIONER FOR PATENTS  
P.O. Box 1450  
Alexandria, Virginia 22313-1450  
www.uspto.gov

APPLICATION NUMBER	FILING OR 371(C) DATE	FIRST NAMED APPLICANT	ATTY. DOCKET NO./TITLE
29/201,636	03/17/2004	Bartley K. Andre	APL1D297

**CONFIRMATION NO. 6966**

**POA ACCEPTANCE LETTER**

63975  
STERNE KESSLER GOLDSTEIN & FOX P.L.L.C.  
1100 NEW YORK AVENUE, N.W.  
WASHINGTON, DC 20005



Date Mailed: 08/07/2009

**NOTICE OF ACCEPTANCE OF POWER OF ATTORNEY**

This is in response to the Power of Attorney filed 08/07/2009.

The Power of Attorney in this application is accepted. Correspondence in this application will be mailed to the above address as provided by 37 CFR 1.33.

/dolipscomb/

Office of Data Management, Application Assistance Unit (571) 272-4000, or (571) 272-4200, or 1-888-786-0101





UNITED STATES PATENT AND TRADEMARK OFFICE

UNITED STATES DEPARTMENT OF COMMERCE  
United States Patent and Trademark Office  
Address: COMMISSIONER FOR PATENTS  
P.O. Box 1450  
Alexandria, Virginia 22313-1450  
www.uspto.gov

APPLICATION NUMBER	FILING OR 371(C) DATE	FIRST NAMED APPLICANT	ATTY. DOCKET NO./TITLE
29/201,636	03/17/2004	Bartley K. Andre	APL1D297

**CONFIRMATION NO. 6966**

**POWER OF ATTORNEY NOTICE**



22434  
Weaver Austin Villeneuve & Sampson LLP  
P.O. BOX 70250  
OAKLAND, CA 94612-0250

Date Mailed: 08/07/2009

**NOTICE REGARDING CHANGE OF POWER OF ATTORNEY**

This is in response to the Power of Attorney filed 08/07/2009.

- The Power of Attorney to you in this application has been revoked by the assignee who has intervned as provided by 37 CFR 3.71. Future correspondence will be mailed to the new address of record(37 CFR 1.33).

/dolipscomb/

Office of Data Management, Application Assistance Unit (571) 272-4000, or (571) 272-4200, or 1-888-786-0101