

Exhibit 2



US008462723B2

(12) **United States Patent**
Stanwood et al.

(10) **Patent No.:** **US 8,462,723 B2**
(45) **Date of Patent:** ***Jun. 11, 2013**

(54) **METHODS AND SYSTEMS FOR TRANSMISSION OF MULTIPLE MODULATED SIGNALS OVER WIRELESS NETWORKS**

FOREIGN PATENT DOCUMENTS

EP 0353759 2/1992
EP 0507384 10/1992

(Continued)

(75) Inventors: **Kenneth L. Stanwood**, Cardiff by the Sea, CA (US); **James F. Mollenauer**, Newton, MA (US); **Israel Jay Klein**, San Diego, CA (US); **Sheldon L. Gilbert**, San Diego, CA (US)

OTHER PUBLICATIONS

Ulm et al., "Data-Over-Cable Interface Specifications, Radio Frequency Interface Specification", Hewlett Packard Interim Specification Doc. Control No. SP-RFII01-970321, published Mar. 21, 1997 by MCNS Holdings, L.P., Section 6, pp. 43-85.

(73) Assignee: **WI-LAN, Inc.**, Ottawa (CA)

(*) Notice: Subject to any disclaimer, the term of this patent is extended or adjusted under 35 U.S.C. 154(b) by 217 days. This patent is subject to a terminal disclaimer.

(Continued)

(21) Appl. No.: **13/089,024**

Primary Examiner — Hassan Kizou

(22) Filed: **Apr. 18, 2011**

Assistant Examiner — Roberta A Shand

(65) **Prior Publication Data**

US 2011/0249585 A1 Oct. 13, 2011

(74) *Attorney, Agent, or Firm* — Procopio, Cory, Hargreaves & Savitch LLP

Related U.S. Application Data

(60) Division of application No. 12/645,937, filed on Dec. 23, 2009, now Pat. No. 8,315,640, which is a continuation of application No. 11/170,392, filed on Jun. 29, 2005, now Pat. No. 8,189,514, which is a continuation of application No. 09/859,561, filed on May 16, 2001, now Pat. No. 6,956,834, which is a continuation of application No. 09/316,518, filed on May 21, 1999, now Pat. No. 6,925,068.

(57) **ABSTRACT**

A method and apparatus for requesting and allocating bandwidth in a broadband wireless communication system. The inventive method and apparatus includes a combination of techniques that allow a plurality of CPEs to communicate their bandwidth request messages to respective base stations. One technique includes a "polling" method whereby a base station polls CPEs individually or in groups and allocates bandwidth specifically for the purpose of allowing the CPEs to respond with bandwidth requests. The polling of the CPEs by the base station may be in response to a CPE setting a "poll-me bit" or, alternatively, it may be periodic. Another technique comprises "piggybacking" bandwidth requests on bandwidth already allocated to a CPE. In accordance with this technique, currently active CPEs request bandwidth using previously unused portions of uplink bandwidth that is already allocated to the CPE. The CPE is responsible for distributing the allocated uplink bandwidth in a manner that accommodates the services provided by the CPE. By using a combination of bandwidth allocation techniques, the present invention advantageously makes use of the efficiency benefits associated with each technique.

(51) **Int. Cl.**
H04W 4/00 (2009.01)

(52) **U.S. Cl.**
USPC **370/329**; 370/341; 455/450

(58) **Field of Classification Search**
None
See application file for complete search history.

(56) **References Cited**

U.S. PATENT DOCUMENTS

3,949,404 A 4/1976 Fletcher et al.
4,464,767 A 8/1984 Bremer

(Continued)

9 Claims, 13 Drawing Sheets

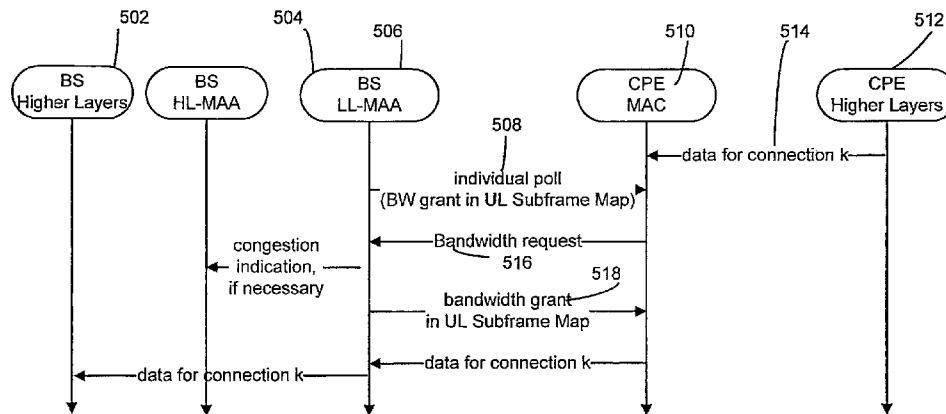

U.S. PATENT DOCUMENTS					
4,495,619 A	1/1985	Acampora	6,151,312 A	11/2000	Evans et al.
4,924,461 A	5/1990	Amemiya et al.	6,198,728 B1	3/2001	Hulyalkar et al.
5,130,983 A	7/1992	Heffner, III	6,212,196 B1 *	4/2001	Momona 370/449
5,297,144 A	3/1994	Gilbert et al.	6,212,200 B1 *	4/2001	Iizuka et al. 370/468
5,349,342 A	9/1994	Nilles et al.	6,216,006 B1	4/2001	Scholefield et al.
5,349,580 A	9/1994	Hester et al.	6,222,832 B1	4/2001	Proctor
5,404,374 A	4/1995	Mullins et al.	6,249,526 B1	6/2001	Loukianov
5,412,651 A *	5/1995	Gorshe 370/412	6,262,980 B1	7/2001	Leung et al.
5,420,851 A	5/1995	Seshadri et al.	6,275,497 B1	8/2001	Varma et al.
5,444,696 A	8/1995	Petranovich	6,282,187 B1	8/2001	Evans et al.
5,444,698 A	8/1995	Kito	6,295,285 B1	9/2001	Whitehead
5,479,447 A	12/1995	Chow et al.	6,298,049 B1 *	10/2001	Vanhoof et al. 370/329
5,506,848 A	4/1996	Drakopoulos et al.	6,314,110 B1	11/2001	Chin et al.
5,511,082 A	4/1996	How et al.	6,324,184 B1	11/2001	Hou et al.
5,517,503 A	5/1996	Hess	6,337,849 B1	1/2002	Smith et al.
5,592,470 A	1/1997	Rudrapatna et al.	6,359,863 B1	3/2002	Varma et al.
5,594,720 A	1/1997	Papadopoulos et al.	6,366,761 B1	4/2002	Montpetit
5,594,738 A	1/1997	Crisler et al.	6,370,153 B1	4/2002	Eng et al.
5,596,576 A	1/1997	Milito et al.	6,373,830 B1	4/2002	Ozluturk
5,596,577 A	1/1997	Perreault et al.	6,374,112 B1	4/2002	Widegren et al.
5,615,212 A	3/1997	Ruszczyc et al.	6,381,228 B1	4/2002	Prieto, Jr. et al.
5,634,006 A	5/1997	Baugher et al.	6,388,999 B1	5/2002	Gorsuch et al.
5,638,371 A	6/1997	Raychaudhuri et al.	6,400,684 B1	6/2002	Benmohamed et al.
5,638,374 A	6/1997	Heath	6,408,005 B1	6/2002	Fan et al.
5,640,395 A	6/1997	Hamalainen et al.	6,424,656 B1	7/2002	Hoebeke
5,644,576 A	7/1997	Bauchot et al.	6,434,164 B1 *	8/2002	Matsunaga et al. 370/443
5,673,031 A	9/1997	Meier	6,438,141 B1	8/2002	Hanko et al.
5,675,573 A	10/1997	Karol et al.	6,452,933 B1	9/2002	Duffield et al.
5,677,909 A	10/1997	Heide	6,469,991 B1	10/2002	Chuah
5,710,762 A	1/1998	Petranovich	6,470,016 B1	10/2002	Kalkunte et al.
5,729,531 A	3/1998	Raith et al.	6,501,745 B1	12/2002	Turina et al.
5,732,078 A	3/1998	Arango et al.	6,546,017 B1 *	4/2003	Khaunte 370/412
5,751,708 A	5/1998	Eng et al.	6,567,386 B1	5/2003	Sugaya et al.
5,768,254 A	6/1998	Papadopoulos et al.	6,567,416 B1	5/2003	Chuah
5,787,080 A	7/1998	Hulyalkar et al.	6,571,101 B1	5/2003	Schulz et al.
5,818,820 A	10/1998	Anderson et al.	6,594,246 B1	7/2003	Jorgensen
5,818,828 A	10/1998	Packer et al.	6,615,039 B1	9/2003	Eldering
5,818,845 A	10/1998	Moura et al.	6,621,812 B1 *	9/2003	Chapman et al. 370/346
5,828,695 A	10/1998	Webb	6,628,668 B1	9/2003	Hutzli
5,859,619 A	1/1999	Wu et al.	6,636,485 B1	10/2003	Fijolek et al.
5,886,989 A	3/1999	Evans et al.	6,650,624 B1	11/2003	Quigley et al.
5,886,995 A	3/1999	Arsenault et al.	6,658,010 B1	12/2003	Enns et al.
5,889,963 A	3/1999	Gopal et al.	6,665,264 B1	12/2003	Davison et al.
5,890,055 A	3/1999	Chu et al.	6,678,282 B2	1/2004	Sharper et al.
5,896,561 A	4/1999	Schrader et al.	6,683,866 B1	1/2004	Stanwood et al.
5,898,925 A	4/1999	Honkasalo et al.	6,693,891 B1	2/2004	Sugita et al.
5,917,822 A	6/1999	Lyles et al.	6,693,892 B1	2/2004	Rinne et al.
5,926,476 A	7/1999	Ghaibeh	6,704,932 B1	3/2004	Matsunaga et al.
5,946,322 A	8/1999	Moura et al.	6,731,600 B1	5/2004	Patel et al.
5,953,344 A	9/1999	Dail et al.	6,741,614 B1	5/2004	Porter et al.
5,956,330 A	9/1999	Kerns	6,754,196 B1	6/2004	Daane et al.
5,956,338 A	9/1999	Ghaibeh	6,771,648 B1	8/2004	Kim et al.
5,956,642 A	9/1999	Larsson et al.	6,771,962 B2	8/2004	Saifullah et al.
5,991,287 A	11/1999	Diepstraten et al.	6,785,252 B1	8/2004	Zimmerman et al.
6,005,853 A	12/1999	Wang et al.	6,791,998 B1	9/2004	Yoshihara et al.
6,005,857 A	12/1999	Honkasalo et al.	6,795,409 B1	9/2004	Youssefmir et al.
6,006,069 A	12/1999	Langston	6,829,482 B2	12/2004	Rune et al.
6,016,311 A	1/2000	Gilbert et al.	6,842,437 B1 *	1/2005	Heath 370/322
6,016,313 A	1/2000	Foster, Jr. et al.	6,862,622 B2	3/2005	Jorgensen
6,023,458 A	2/2000	Tweedy et al.	6,895,248 B1	5/2005	Akyol et al.
6,031,827 A	2/2000	Rikkinen et al.	6,914,890 B1	7/2005	Tobita et al.
6,031,845 A	2/2000	Walding et al.	6,925,068 B1	8/2005	Stanwood et al.
6,038,223 A	3/2000	Hansson et al.	6,937,566 B1	8/2005	Forslow
6,038,455 A	3/2000	Gardner et al.	6,940,874 B2	9/2005	Ruszczyc et al.
6,047,189 A	4/2000	Yun et al.	6,944,148 B1	9/2005	Gehring et al.
6,049,549 A	4/2000	Ganz et al.	6,956,834 B2	10/2005	Stanwood et al.
6,049,551 A	4/2000	Hinderks et al.	6,970,422 B1	11/2005	Ho et al.
6,052,594 A	4/2000	Chuang et al.	7,006,530 B2	2/2006	Spinar et al.
6,061,330 A	5/2000	Johansson	7,047,009 B2	5/2006	Laroia et al.
6,075,787 A *	6/2000	Bobbeck et al. 370/395.2	7,050,407 B1	5/2006	Frazer et al.
6,094,421 A	7/2000	Scott	7,103,065 B1	9/2006	Quigley et al.
6,097,733 A *	8/2000	Basu et al. 370/468	7,116,682 B1	10/2006	Waclawski
6,104,700 A	8/2000	Haddock et al.	7,177,323 B2	2/2007	Yavatkar et al.
6,112,080 A	8/2000	Anderson et al.	7,333,495 B2	2/2008	Sala et al.
6,114,968 A	9/2000	Ramakrishnan et al.	7,356,339 B2	4/2008	Nam
6,115,390 A	9/2000	Chuah	7,408,901 B1	8/2008	Narayanabhatla
6,137,787 A	10/2000	Chawla et al.	7,418,007 B1	8/2008	Liu et al.
6,141,534 A	10/2000	Snell et al.	7,486,639 B2	2/2009	Stanwood et al.
			7,512,154 B2	3/2009	Quigley et al.

7,548,534	B2	6/2009	Zimmerman et al.
7,562,130	B2	7/2009	Dillon et al.
7,636,571	B2	12/2009	Lee et al.
7,693,093	B2	4/2010	Riedel et al.
7,751,437	B2	7/2010	Spinar et al.
7,783,311	B2	8/2010	Takiishi et al.
7,809,373	B2	10/2010	Park et al.
7,817,666	B2	10/2010	Spinar et al.
7,962,139	B2	6/2011	Kangude et al.
8,027,298	B2	9/2011	Stanwood et al.
8,085,891	B2	12/2011	Owen
8,131,295	B2	3/2012	Wang et al.
8,189,514	B2	5/2012	Stanwood et al.
8,243,663	B2	8/2012	Spinar et al.
8,249,014	B2	8/2012	Stanwood et al.
8,249,051	B2	8/2012	Spinar et al.
2001/0038620	A1	11/2001	Stanwood et al.
2002/0080816	A1	6/2002	Spinar et al.
2004/0213197	A1	10/2004	Zimmerman et al.
2005/0047368	A1	3/2005	Kotzin et al.
2005/0089064	A1	4/2005	Zimmerman et al.
2005/0111409	A1	5/2005	Spear et al.
2006/0002336	A1	1/2006	Stanwood et al.
2008/0049678	A1	2/2008	Chindapol et al.
2008/0232342	A1	9/2008	Spinar et al.
2008/0232391	A1	9/2008	Spinar et al.
2008/0253394	A1	10/2008	Spinar et al.
2008/0268844	A1	10/2008	Ma et al.
2009/0168802	A1	7/2009	Spinar et al.
2009/0175235	A1	7/2009	Spinar et al.
2009/0207795	A1	8/2009	Spinar et al.
2010/0150093	A1	6/2010	Stanwood et al.
2010/0150094	A1	6/2010	Stanwood et al.
2010/0157928	A1	6/2010	Spinar et al.
2011/0249586	A1	10/2011	Stanwood et al.
2011/0249645	A1	10/2011	Spinar et al.
2011/0292904	A1	12/2011	Stanwood et al.
2012/0033634	A1	2/2012	Spinar et al.

FOREIGN PATENT DOCUMENTS

EP	0622924	4/1994
EP	0720405	7/1996
EP	0845916	6/1998
EP	0891060	1/1999
EP	1045559	10/2000
GB	2320162	12/1996
JP	11122289 A	4/1999
WO	WO92/22162	12/1992
WO	WO9810568	3/1998
WO	9837706 A2	8/1998
WO	9907170 A2	2/1999
WO	WO99/38343	8/1999
WO	WO99/39532	8/1999
WO	WO00/01188	1/2000
WO	WO0072626	11/2000
WO	WO01/33772	5/2001

OTHER PUBLICATIONS

Qiu et al., Dynamic Reservation Multiple Access (DRMA): A New Multiple Access Scheme for Personal Communication System (PCS), *Wireless Networks 2* (1996), pp. 117-128, J.C. Baltzer AG, Science Publishers.

Kim, et al., PRMA/DA: A New Media Access Control Protocol for Wireless ATM, *IEEE*, Jun. 23, 1996, pp. 240-244.

U.S. District Court, Northern District of California, "Amended Complaint for Declaratory Judgment Demand for Jury Trial" filed Sep. 30, 2008 in Case No. 5:08-cv-4555, 20 pages.

Harry J.R. Dutton, P. Leuhard, *Asynchronous Transfer Mode (ATM) Technical Overview*, 2.sup.nd Edition, Prentice Hall Oct. 1995, Chap. 3, pp. 21-25.

C.E. Shannon, "A Mathematical Theory of Communication", *Bell System Technical Journal*, pp. 379-423 (Part 1), 623-656 (Part 2), Jul. 1948.

Conti et al., E-DCP, an extension of the distributed-control polling MAC protocol (DCP) for integrated services, published 1994, pp. 711-719.

Effeitieri et al., A MAC Protocol for supporting real-time VBR traffic over IEEE 802.14 based HFC access networks, Published May 9-12, 1999, pp. 197-201.

G. Narlikar, et al., Designing Multihop Wireless Backhand Networks with Delay Guarantees, Bell Labs, 2005, 1-4244-0222-0/06/\$20.00 2006 IEEE, 12 pages.

J. Pons and J. Dunlop, Bit Error Rate Characterisation and Modelling for GSM, *IEEE* 1998, pp. 3722-3727.

J.B. Andersen, et al., Prediction of Future Fading Based on Past Measurements, Vehicular Technology Conference, VTC 99, vol. 1, p. 151-155.

J.M. Torrance, et al., Upper Bound Performance of Adaptive Modulation in a Slow Rayleigh Fading Channel, 2 pages.

L.H. Charles Lee, "Convolutional Coding, Fundamentals and Applications", Artech House, Inc., 1997, p. 11-51.

Lin et al., "Error Control Coding, Fundamentals and Applications", Prentice-Hall Computer Applications in Electrical Engineering Series., 1993, pp. 315-349.

Lin, Ying-Dar, On IEEE 802.14 Medium Access Control Protocol, *IEEE Communications Surveys*, <http://www.comsoc.org/pubs/surveys>, Fourth Quarter 1998, vol. 1 No. 1, pp. 1-10.

Mollenauer, James F. et al., "An Efficient Media Access Control Protocol for Broadband Wireless Access Systems", Submission to IEEE 802.16 Broadband Wireless Access Working Group, Oct. 28, 1999, pp. 1-18.

Mollenauer, James F., et al., "MAC Proposal for IEEE 802.16.1", Submission to IEEE 802.16 Broadband Wireless Access Working Group, Dec. 24, 1999, pp. 1-84.

P. Bender et al., CDMA/HDR: A Bandwidth Efficient High Speed Wireless Data Service for Nomadic Users, *Communications Magazine*, *IEEE*, vol. 38, No. 7, Jul, 2000, pp. 70-77.

P. Jain, On the Impact of Channel and Channel Quality Estimation on Adaptive Modulation, Dec. 2002, 92 pages.

Redl, et al., "An Introduction to GSM", Artech House, Inc., 1995, pp. 84-85 and 95.

Superseded Data-Over-Cable Service Interface Specifications, Radio Frequency Interface Specification, SP-RF1v1.1-101-990311 (DOCSIS1.1), dated Mar. 11, 1999, <http://www.cablelabs.com/specifications/SP/RF1v1.1-101-990311.pdf>, pp. 1310, 320 pages.

Wolf et al., "On the Weight Distribution of Linear Block Codes Formed From Convolutional Codes", *IEEE, IEEE Transactions on Communications*, vol. 44:9, Sep. 9, 1996, pp. 1049-1051.

Sampei et al., Adaptive Modulation/TDMA Scheme for Personal Multi-Media Communication System, Proceedings of the Global Telecommunications Conference, U.S., New York, IEEE, Nov. 28, 1994, pp. 989-993.

Ue et al., Symbol Rate and Modulation Level Controlled Adaptive Modulation/TDMA/TDD for Personal Communication Systems, Proceedings of the Vehicular Technology Conference, U.S., New York, IEEE, vol. Conf. 45, Jul. 25, 1995, pp. 306-310.

Papadopoulos et al., "Reduction of Mixed Co-channel Interference in Microcellular STDD Systems", Vehicular Technology Conference, 1995 *IEEE* 45.sup.th, vol. 2, pp. 759-763.

United States District Court, Southern District of Florida. *Wi-LAN USA, Inc. and Wi-LAN, Inc.*, Plaintiffs, v. *HTC Corporation, and HTC America, Inc.*, Defendants. "Complaint." Entered Dec. 6, 2012. Case No. 1:12-cv-24319-KMM. 6 pages.

United States District Court, Southern District of Florida. *Wi-LAN USA, Inc. and Wi-LAN, Inc.*, Plaintiffs, v. *Apple Inc.*, Defendant. "Complaint." Entered Dec. 6, 2012. Case No. 1:12-cv-24318-KMM. 6 pages.

United States District Court, Southern District of Florida. *Wi-LAN USA, Inc. and Wi-LAN, Inc.*, Plaintiffs, v. *Sierra Wireless America, Inc.*, Defendant. "Complaint." Entered Dec. 6, 2012. Case No. 1:12-cv-24320-KMM. 6 pages.

United States District Court, Southern District of Florida. *Wi-LAN USA, Inc. and Wi-LAN, Inc.*, Plaintiffs, v. *Telefonaktiebolaget LM Ericsson, and Ericsson Inc.*, Defendants. "Complaint." Entered Oct. 1, 2012. Case No. 1:12-cv-23569-DMM. 7 pages.

United States District Court, Southern District of Florida. *Wi-LAN USA, Inc. and Wi-LAN, Inc.*, Plaintiffs, v. *Alcatel-Lucent USA Inc.*, Defendant. "Complaint." Entered Oct. 1, 2012. Case No. 1:12-cv-23568-CMA. 7 pages.

* cited by examiner

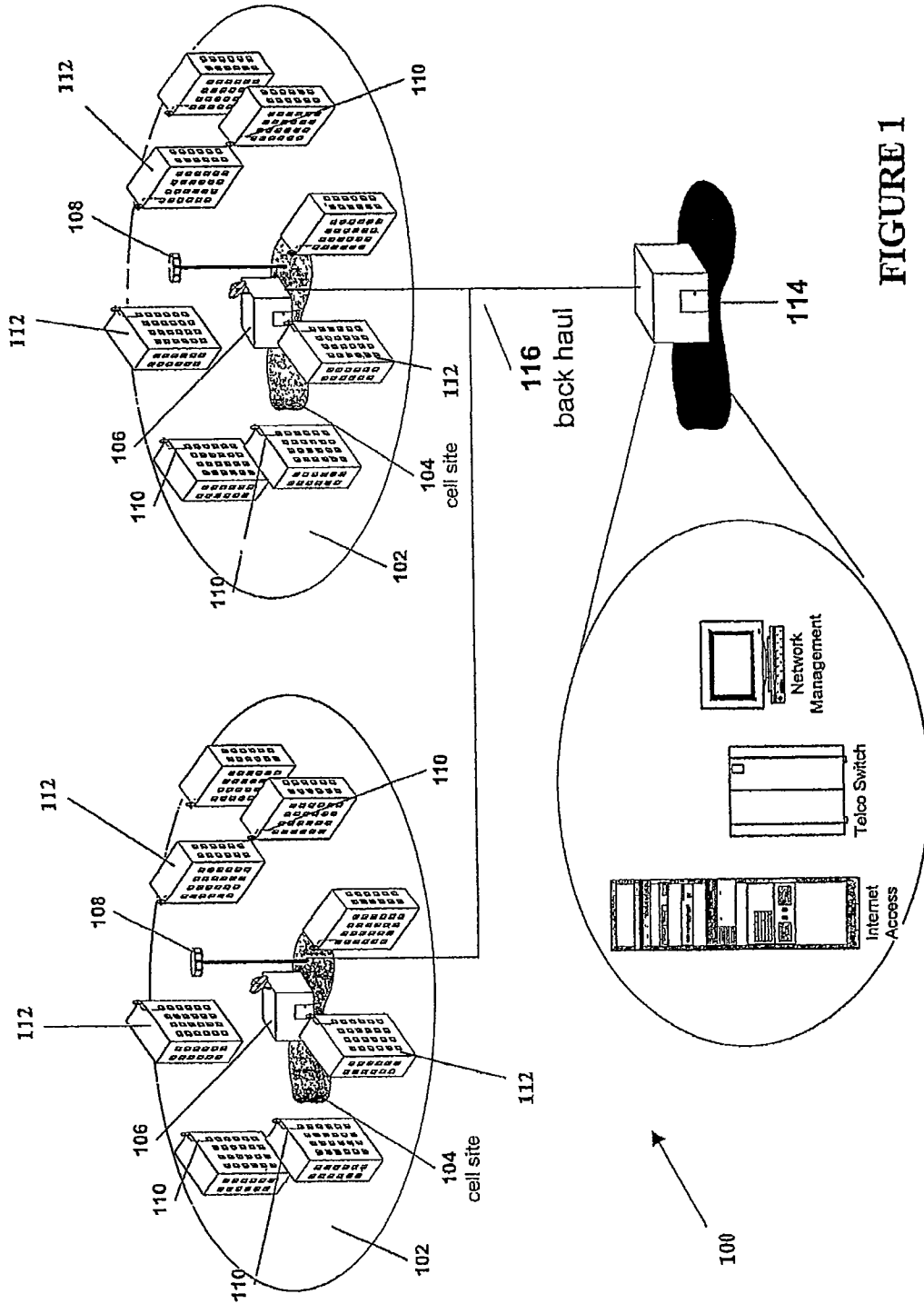

FIGURE 1

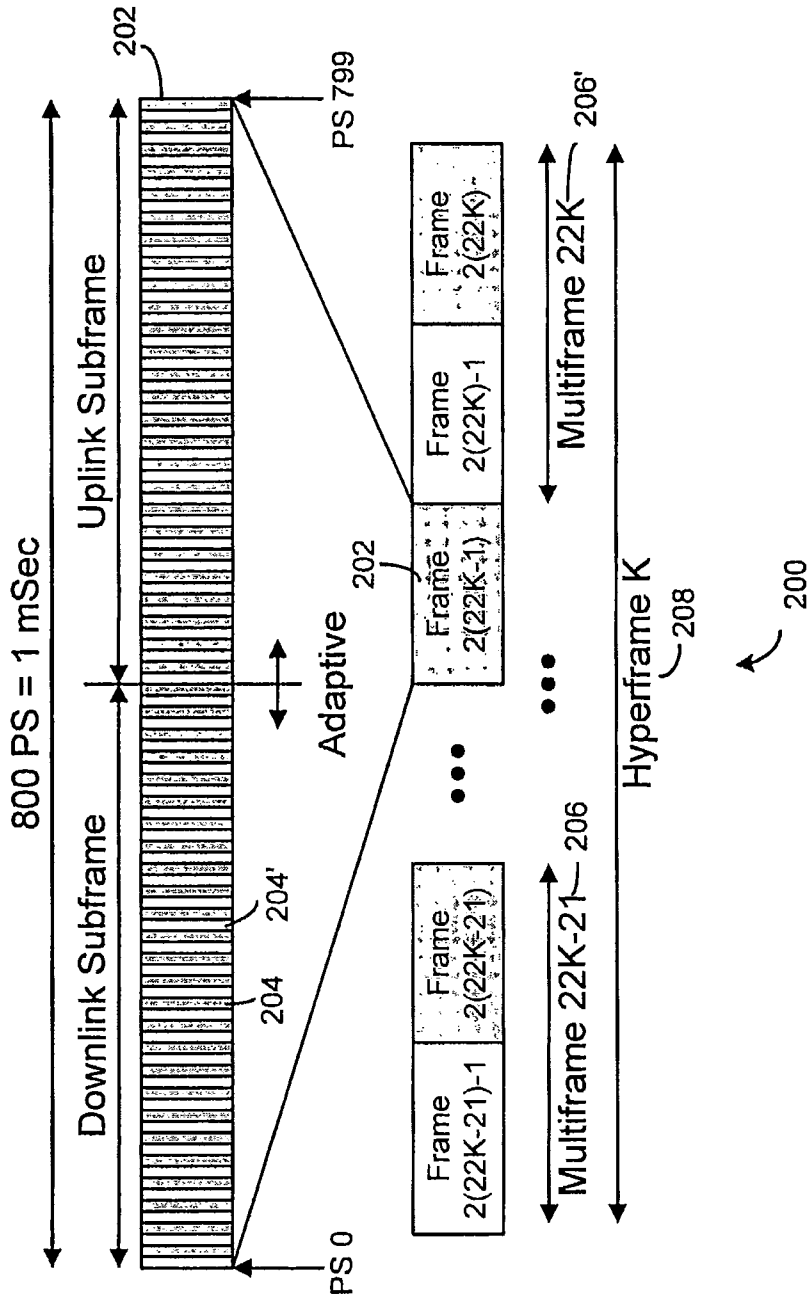

FIGURE 2

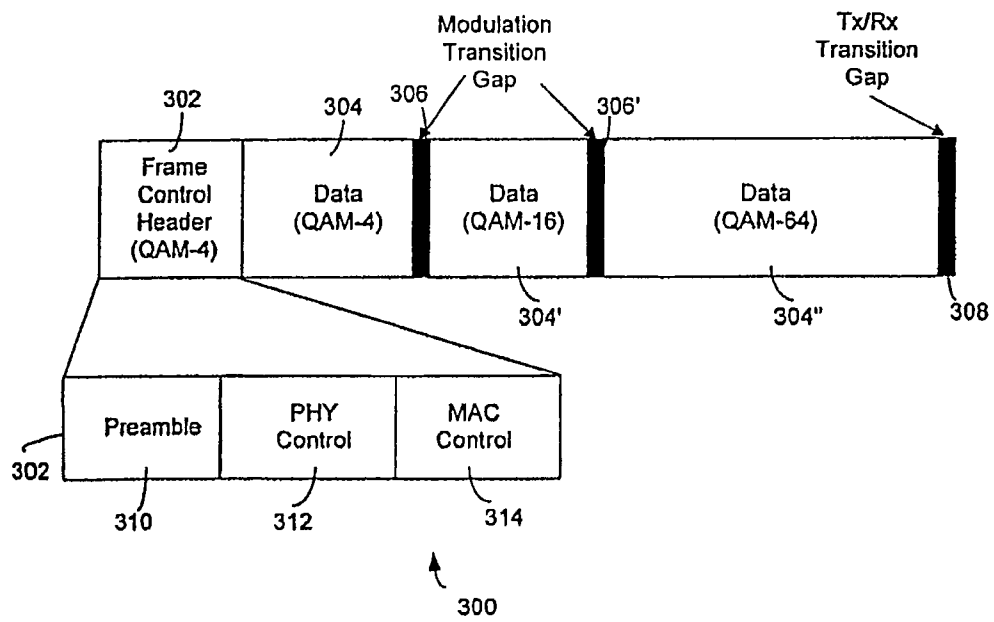

FIGURE 3

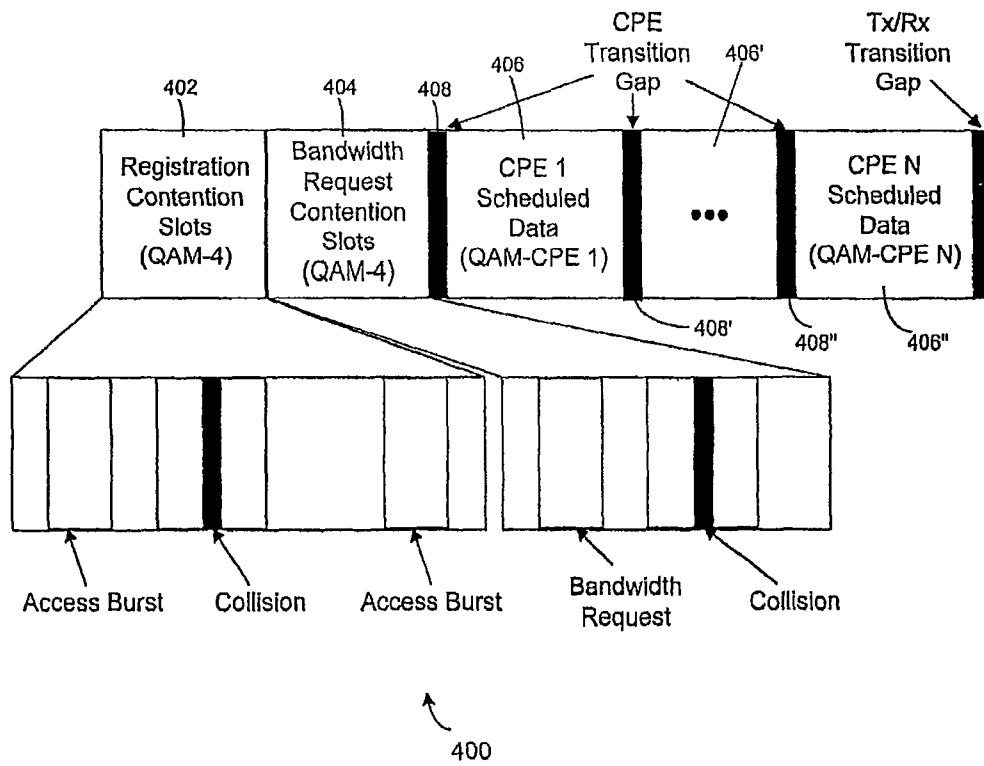

FIGURE 4

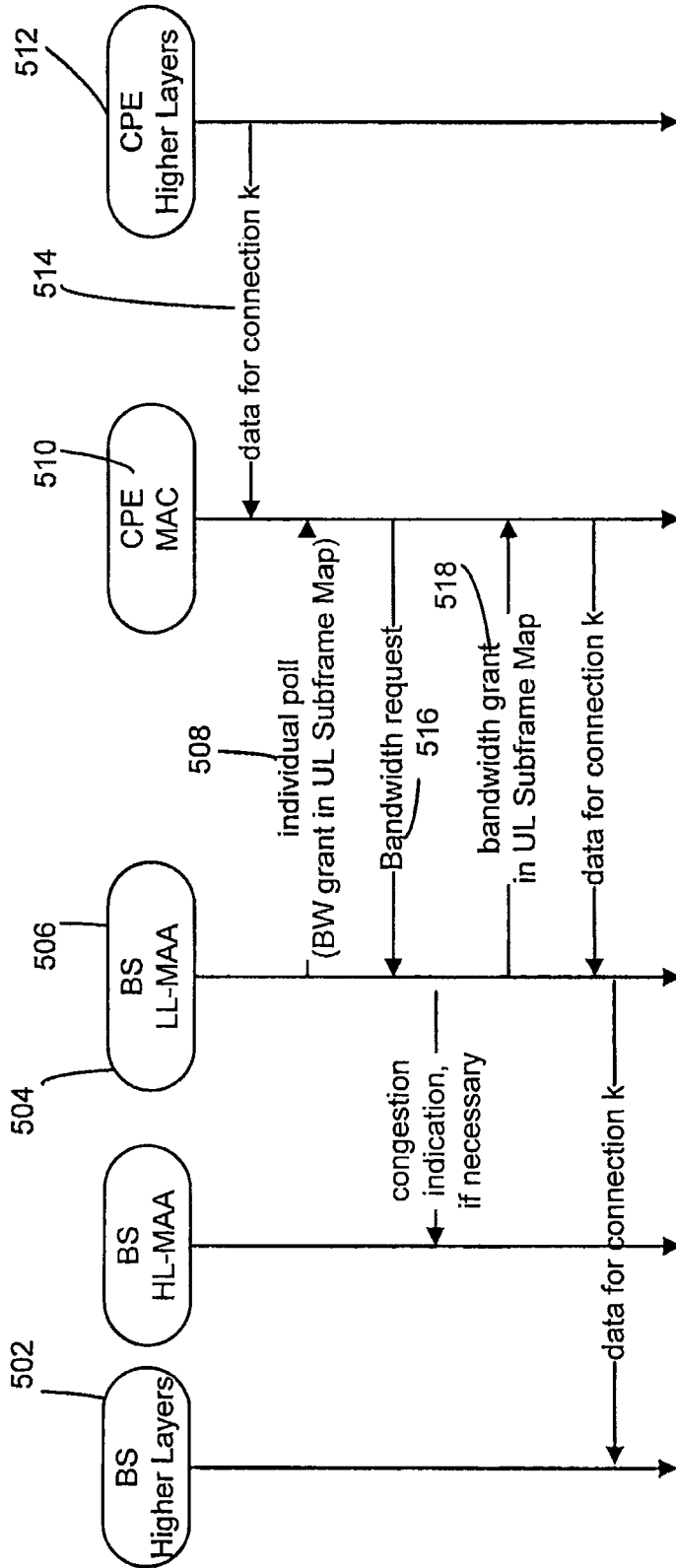

FIGURE 5

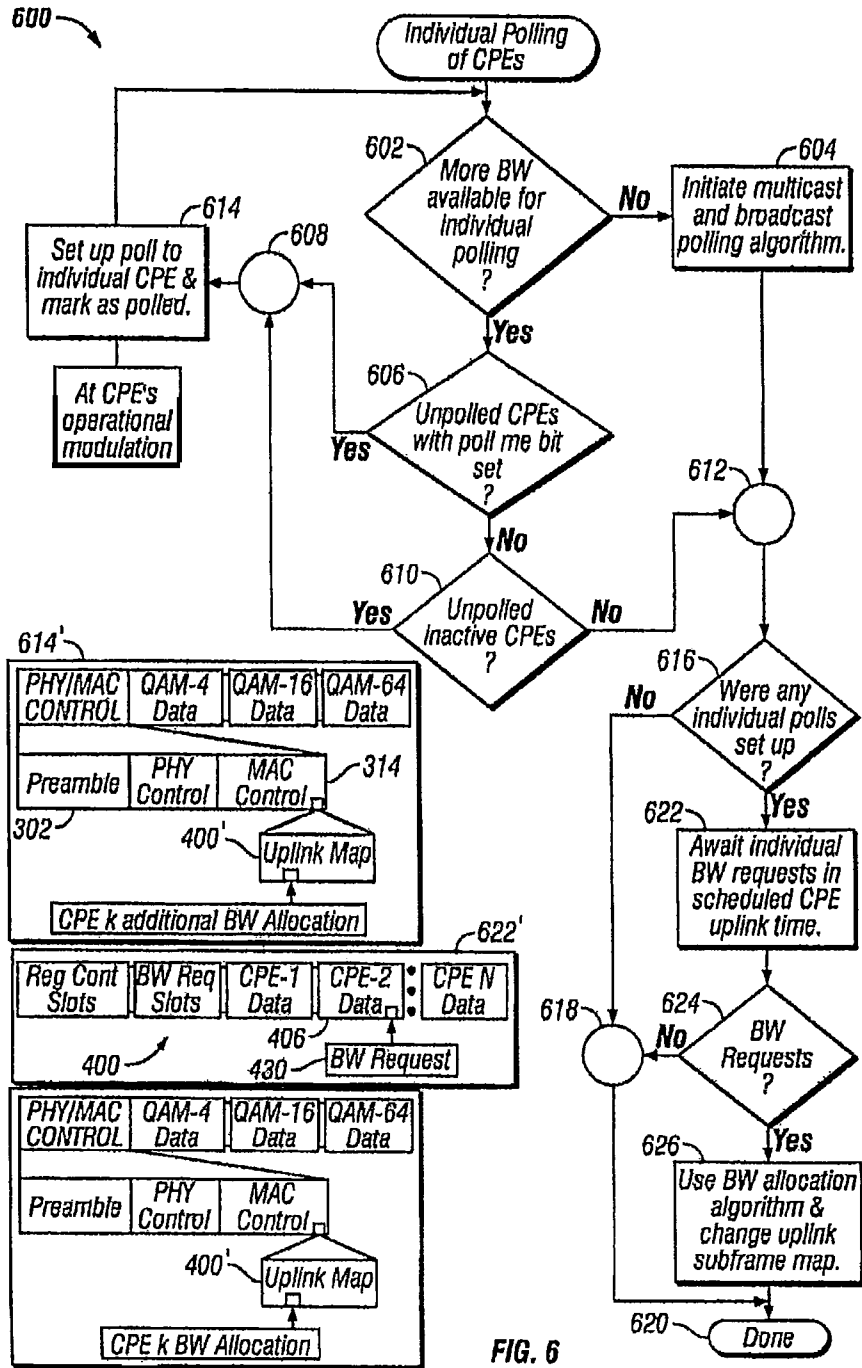

FIG. 6

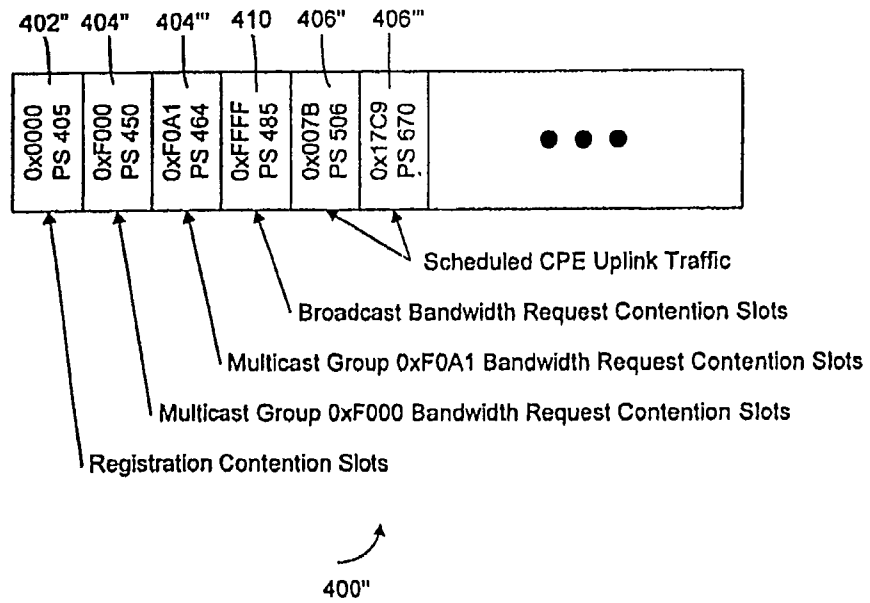

FIGURE 7

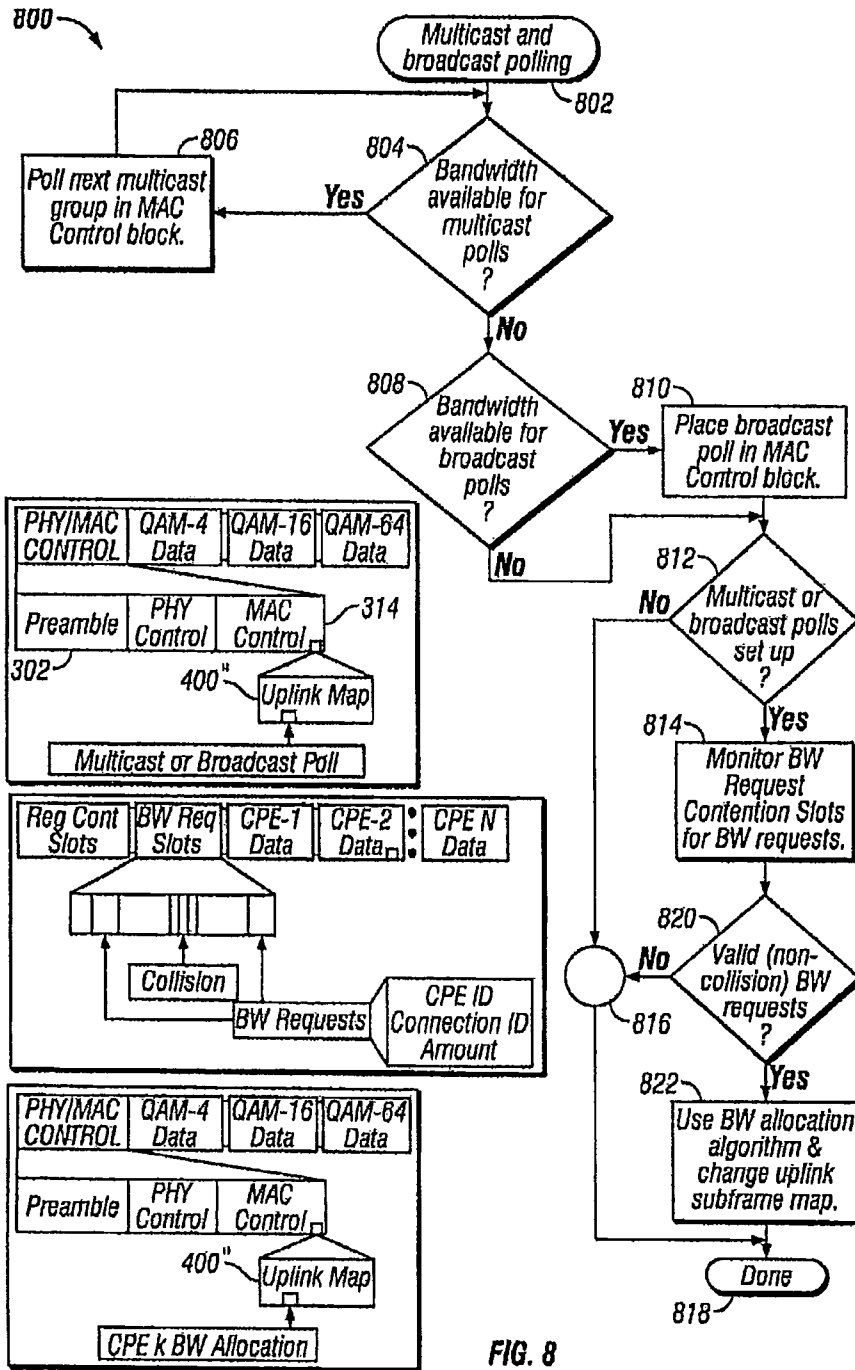

FIG. 8

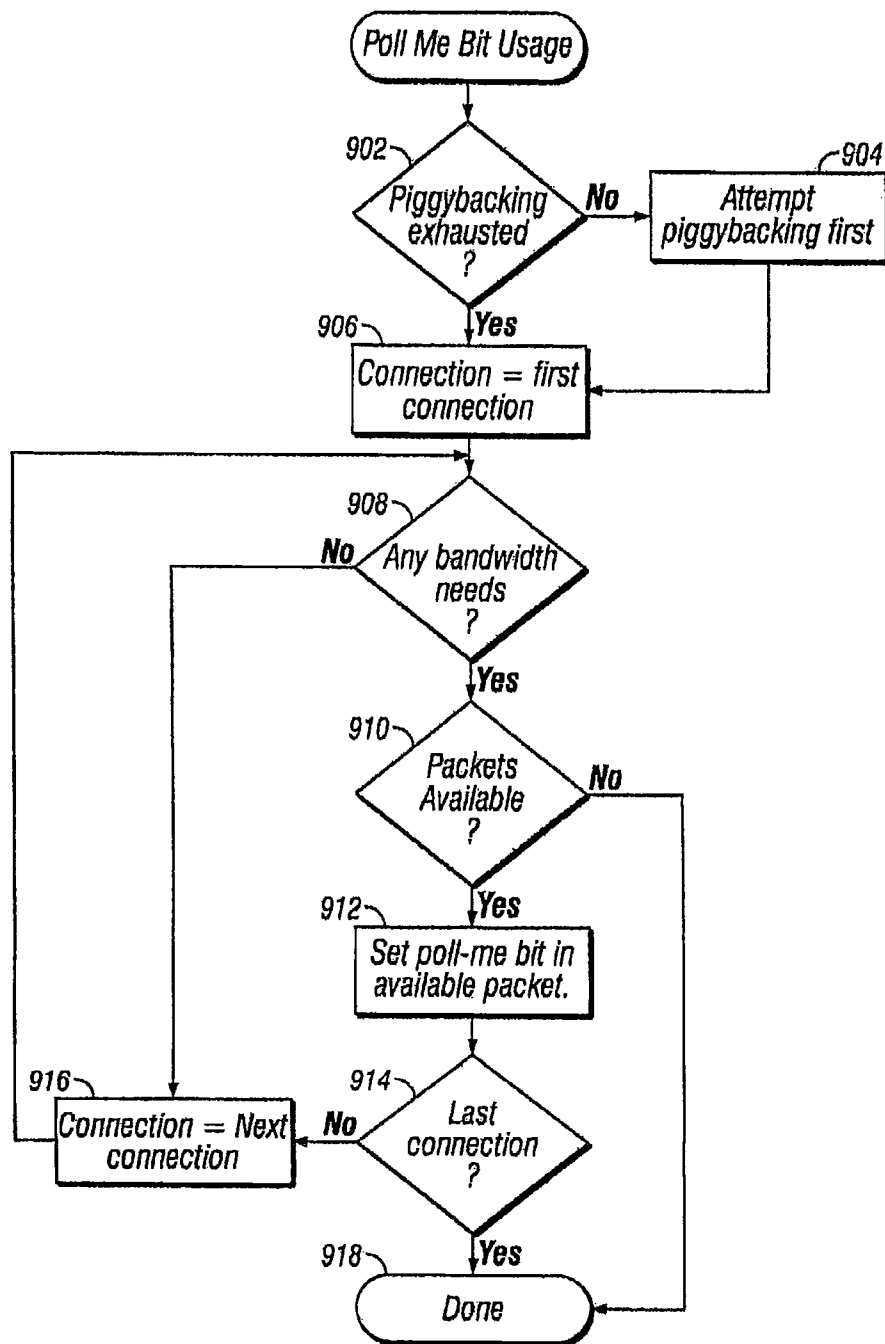

FIG. 9

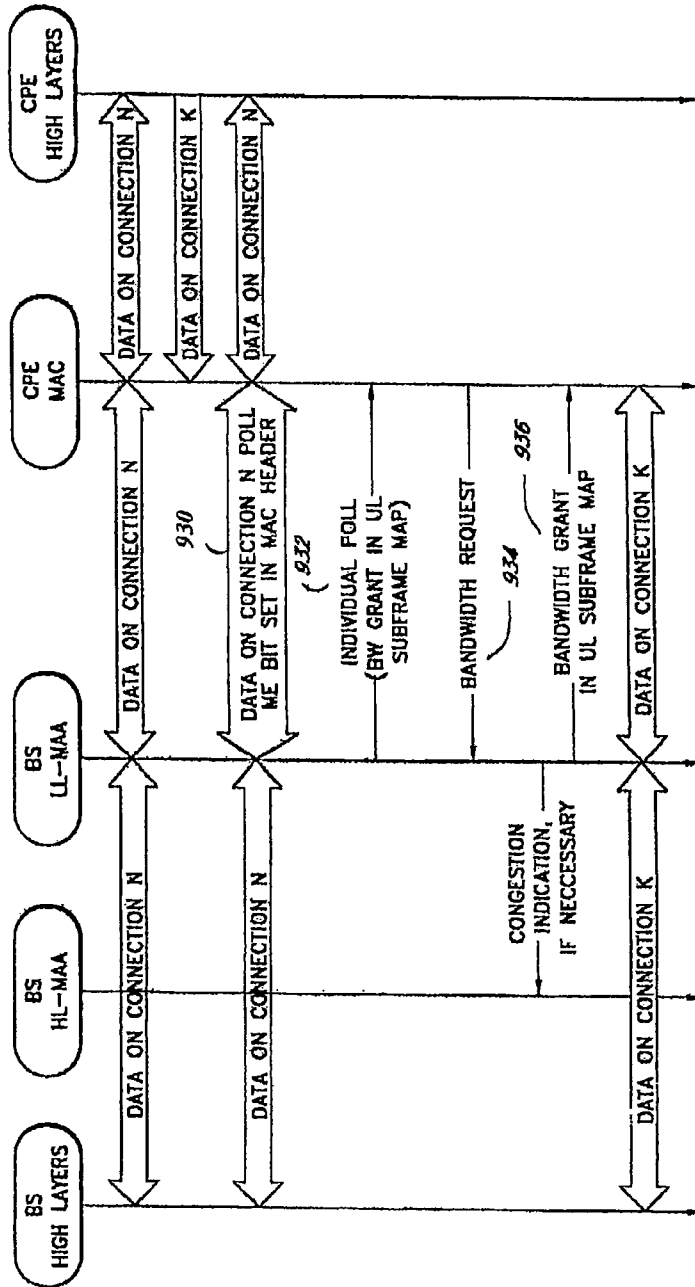

FIG. 10

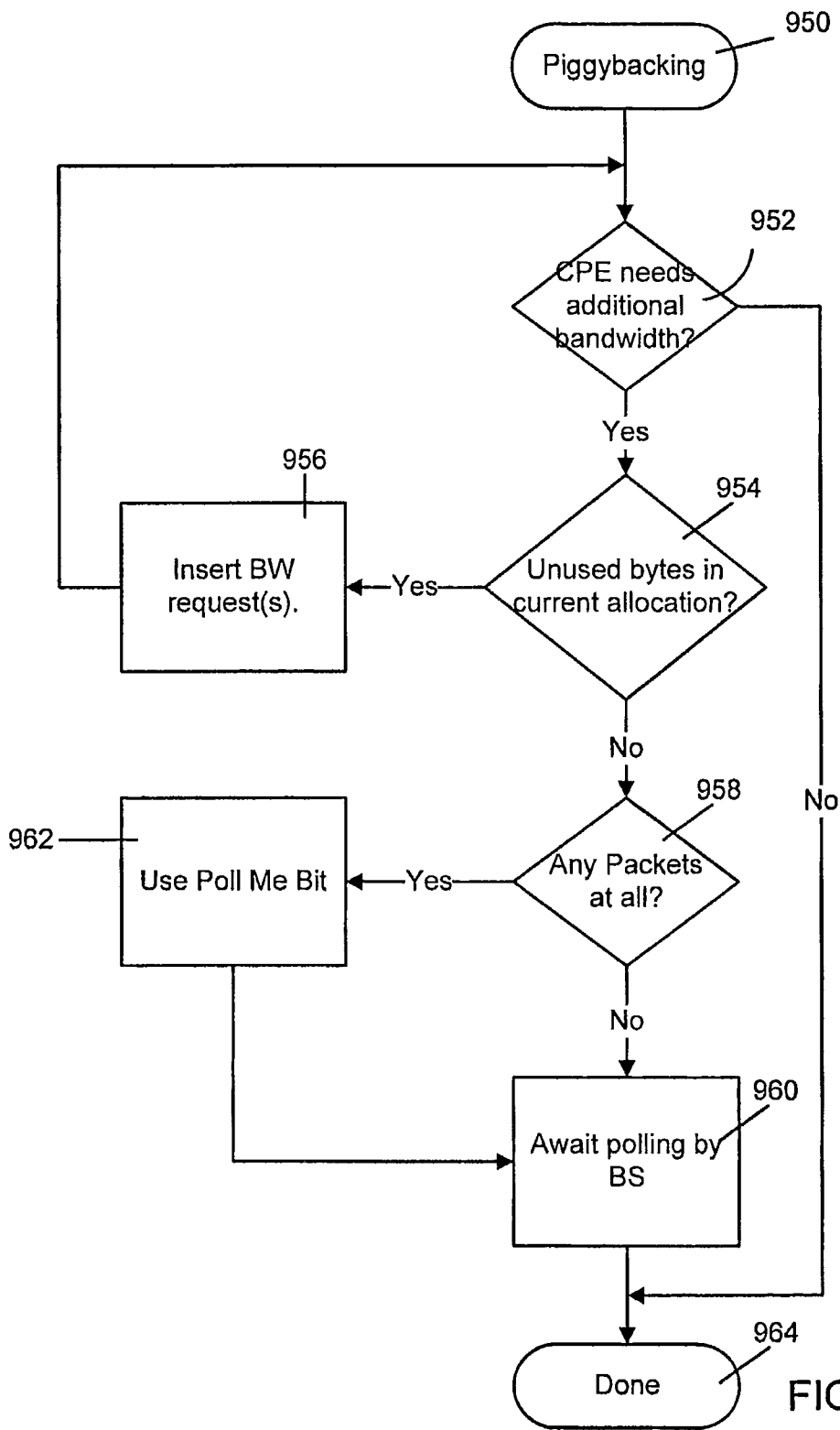

FIGURE 11

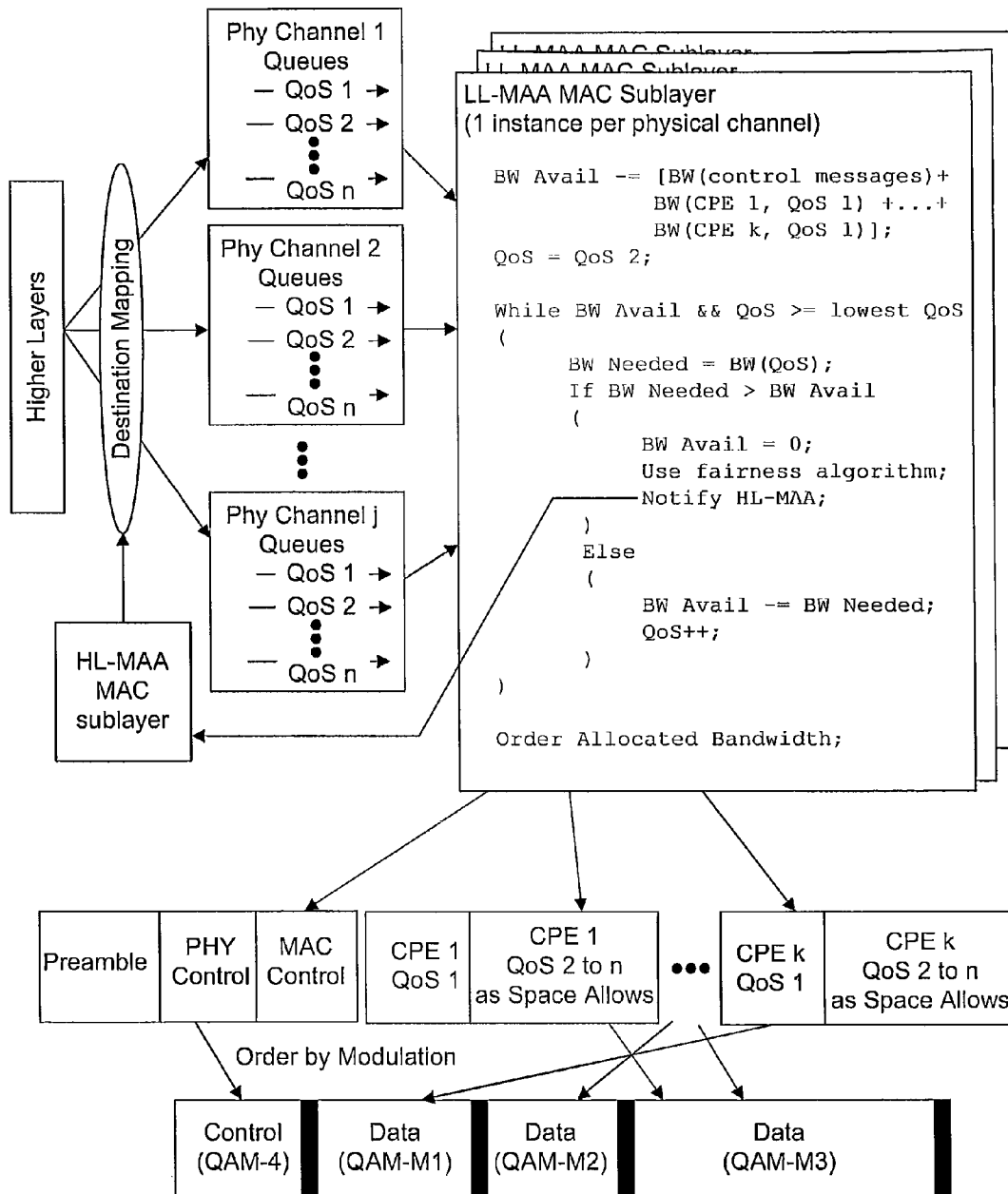

FIGURE 12

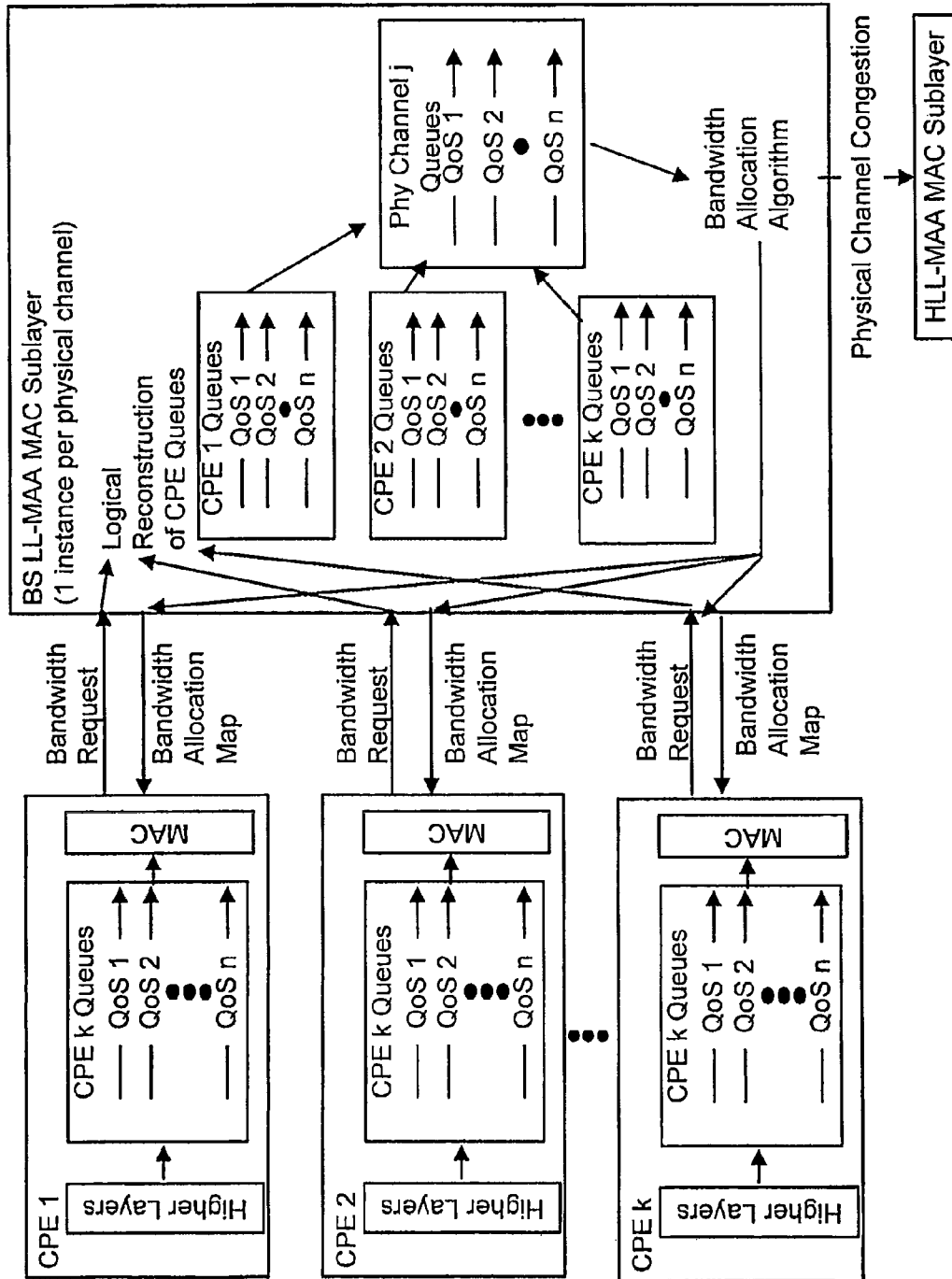

FIGURE 13

**METHODS AND SYSTEMS FOR
TRANSMISSION OF MULTIPLE
MODULATED SIGNALS OVER WIRELESS
NETWORKS**

CROSS-REFERENCE TO RELATED
APPLICATION

This application is a divisional of 12/645,937, filed Dec. 23, 2009, which is a continuation of U.S. patent application Ser. No. 11/170,392, filed Jun. 29, 2005, which is a continuation of U.S. patent application Ser. No. 09/859,561, filed May 16, 2001, now U.S. Pat. No. 6,956,834, which is a continuation of U.S. patent application Ser. No. 09/316,518, filed May 21, 1999, now U.S. Pat. No. 6,925,068, the disclosures of which are incorporated herein by reference in its entirety.

BACKGROUND OF THE INVENTION

1. Field of the Invention

This invention relates to wireless communication systems, and more particularly to a method and apparatus for efficiently allocating bandwidth between base stations and customer premises equipment in a broadband wireless communication system.

2. Description of Related Art

As described in U.S. Pat. No. 6,016,311, by Gilbert et al., issued Jan. 18, 2000, entitled "Adaptive Time Division Duplexing Method and Apparatus for Dynamic Bandwidth Allocation within a Wireless Communication System," hereby incorporated by reference, a wireless communication system facilitates two-way communication between a plurality of subscriber radio stations or subscriber units (fixed and portable) and a fixed network infrastructure. Exemplary communication systems include mobile cellular telephone systems, personal communication systems (PCS), and cordless telephones. The key objective of these wireless communication systems is to provide communication channels on demand between the plurality of subscriber units and their respective base stations in order to connect a subscriber unit user with the fixed network infrastructure (usually a wire-line system). In the wireless systems having multiple access schemes a time "frame" is used as the basic information transmission unit. Each frame is sub-divided into a plurality of time slots. Some time slots are used for control purposes and some for information transfer. Subscriber units typically communicate with the base station using a "duplexing" scheme thus allowing the exchange of information in both directions of connection.

Transmissions from the base station to the subscriber unit are commonly referred to as "downlink" transmissions. Transmissions from the subscriber unit to the base station are commonly referred to as "uplink" transmissions. Depending upon the design criteria of a given system, the prior art wireless communication systems have typically used either time division duplexing (TDD) or frequency division duplexing (FDD) methods to facilitate the exchange of information between the base station and the subscriber units. Both the TDD and FDD duplexing schemes are well known in the art.

Recently, wideband or "broadband" wireless communications networks have been proposed for providing delivery of enhanced broadband services such as voice, data and video services. The broadband wireless communication system facilitates two-way communication between a plurality of base stations and a plurality of fixed subscriber stations or Customer Premises Equipment (CPE). One exemplary broad-

band wireless communication system is described in the co-pending application and is shown in the block diagram of FIG. 1. As shown in FIG. 1, the exemplary broadband wireless communication system 100 includes a plurality of cells 102. Each cell 102 contains an associated cell site 104 that primarily includes a base station 106 and an active antenna array 108. Each cell 102 provides wireless connectivity between the cell's base station 106 and a plurality of customer premises equipment (CPE) 110 positioned at fixed customer sites 112 throughout the coverage area of the cell 102. The users of the system 100 may include both residential and business customers. Consequently, the users of the system have different and varying usage and bandwidth requirement needs. Each cell may service several hundred or more residential and business CPEs.

The broadband wireless communication system 100 of FIG. 1 provides true "bandwidth-on-demand" to the plurality of CPEs 110. CPEs 110 request bandwidth allocations from their respective base stations 106 based upon the type and quality of services requested by the customers served by the CPEs. Different broadband services have different bandwidth and latency requirements. The type and quality of services available to the customers are variable and selectable. The amount of bandwidth dedicated to a given service is determined by the information rate and the quality of service required by that service (and also taking into account bandwidth availability and other system parameters). For example, T1-type continuous data services typically require a great deal of bandwidth having well-controlled delivery latency. Until terminated, these services require constant bandwidth allocation on each frame. In contrast, certain types of data services such as Internet protocol data services (TCP/IP) are bursty, often idle (which at any one instant requires zero bandwidth), and are relatively insensitive to delay variations when active.

Due to the wide variety of CPE service requirements, and due to the large number of CPEs serviced by any one base station, the bandwidth allocation process in a broadband wireless communication system such as that shown in FIG. 1 can become burdensome and complex. This is especially true with regard to the allocation of uplink bandwidth. Base stations do not have a priori information regarding the bandwidth or quality of services that a selected CPE will require at any given time. Consequently, requests for changes to the uplink bandwidth allocation are necessarily frequent and varying. Due to this volatility in the uplink bandwidth requirements, the many CPEs serviced by a selected base station will need to frequently initiate bandwidth allocation requests. If uncontrolled, the bandwidth allocation requests will detrimentally affect system performance. If left unchecked, the bandwidth required to accommodate CPE bandwidth allocation requests will become disproportionately high in comparison with the bandwidth allocated for the transmission of substantive traffic data. Thus, the communication system bandwidth available to provide broadband services will be disadvantageously reduced.

Therefore, a need exists for a method and apparatus that can dynamically and efficiently allocate bandwidth in a broadband wireless communication system. The method and apparatus should be responsive to the needs of a particular communication link. The bandwidth needs may vary due to several factors, including the type of service provided over the link and the user type. The bandwidth allocation method and apparatus should be efficient in terms of the amount of system bandwidth consumed by the actual bandwidth request and allocation process. That is, the plurality of bandwidth requests generated by the CPE should consume a minimum

percentage of available uplink bandwidth. In addition, the bandwidth allocation method and apparatus should respond to bandwidth requests in a timely manner. Bandwidth should be allocated to high priority services in a sufficiently short time frame to maintain the quality of service specified by the CPE. Further, the bandwidth allocation method and apparatus should be capable of processing an arbitrarily large number of bandwidth allocation requests from a relatively large number of CPEs. For example, in the system shown in FIG. 1, as many as one hundred CPEs may be allowed to be simultaneously active, coordinating their transmissions on the uplink. Furthermore, the system can accommodate approximately one thousand CPEs on the physical channel. Therefore, the need exists for a bandwidth allocation method and apparatus that can process and respond to the bandwidth allocation requests generated by a large number of CPEs.

Some prior art systems have attempted to solve bandwidth allocation requirements in a system having a shared system resource by maintaining logical queues associated with the various data sources requiring access to the shared system resource. Such a prior art system is taught by Karol et al., in U.S. Pat. No. 5,675,573, that issued on Oct. 7, 1997. More specifically, Karol et al. teach a bandwidth allocation system that allows packets or cells within traffic flows from different sources that are contending for access to a shared processing fabric to get access to that fabric in an order that is determined primarily on individual guaranteed bandwidth requirements associated with each traffic flow. In addition, the system taught by Karol et al. allow the different sources to gain access to the shared processing fabric in an order determined secondarily on overall system criteria, such as a time of arrival, or due date of packets or cells within the traffic flows. Packets or cells of data from each data source (such as a bandwidth requesting device) are queued in separate logical buffers while they await access to the processing fabric.

A need exists for a bandwidth allocation method and apparatus for efficiently processing and responding to bandwidth allocation requests. The bandwidth allocation method and apparatus should accommodate an arbitrarily large number of CPEs generating frequent and varying bandwidth allocation requests on the uplink of a wireless communication system. Such a bandwidth allocation method and apparatus should be efficient in terms of the amount of bandwidth consumed by the bandwidth request control messages exchanged between the plurality of base stations and the plurality of CPEs. In addition, the bandwidth allocation method and apparatus should respond to the bandwidth allocation requests in a timely and accurate manner. The bandwidth allocation method and apparatus should also be able to process an arbitrarily large number of bandwidth allocation requests generated by a relatively large number of CPEs. The present invention provides such a bandwidth allocation method and apparatus.

SUMMARY OF THE INVENTION

The present invention is a novel method and apparatus for requesting and allocating bandwidth in a broadband wireless communication system. The method and apparatus reduces the amount of bandwidth that must be allocated for bandwidth request and bandwidth allocation purposes. The opportunities for allowing a CPE to request bandwidth are very tightly controlled in accordance with the present invention. The present invention utilizes a combination of a number of bandwidth request and allocation techniques to control the

bandwidth request process. There are a number of means by which a CPE can transmit a bandwidth request message to an associated base station.

One such means uses a "polling" technique whereby a base station polls one or more CPEs and allocates bandwidth specifically for the purpose of allowing the CPEs to respond with a bandwidth request. The polling of the CPEs by the base station may be in response to a CPE setting a "poll-me bit" or, alternatively, it may be periodic. In accordance with the present invention, periodic polls may be made to individual CPEs, to groups of CPEs, or to every CPE on a physical channel. When individually polling a CPE, the base station polls an individual CPE by allocating uplink bandwidth in an uplink sub-frame map to allow the CPE to respond with a bandwidth request. Similarly, in group polling, the base station polls several CPEs by allocating uplink bandwidth in the uplink sub-frame map to allow the CPEs to respond with a bandwidth request. The CPEs must contend for the allocated bandwidth if collisions occur. Bandwidth allocations are not in the form of an explicit message that is communicated by the base station to the CPEs, but rather the bandwidth allocations are transmitted implicitly by allocating bandwidth in the uplink sub-frame map.

Another means used by the present invention in reducing bandwidth consumed by the bandwidth request messages is the technique of "piggybacking" bandwidth requests on bandwidth already allocated to a CPE. In accordance with this technique, currently active CPEs request bandwidth using previously unused portions of uplink bandwidth that is already allocated to the CPE. Alternatively, the bandwidth requests can be piggybacked on uplink bandwidth already allocated and currently being used by a data service. In accordance with this alternative, the CPE "steals" bandwidth already allocated for a data connection by inserting bandwidth requests in time slots previously used for data.

The CPE is responsible for distributing the allocated uplink bandwidth in a manner that accommodates the services provided by the CPE. The CPE is free to use the uplink bandwidth that was allocated to it in a manner that is different than that originally requested or granted by the base station. The CPE advantageously determines which services to give bandwidth to and which services must wait for subsequent bandwidth requests. One advantage of having the CPE determine how to distribute its allocated bandwidth is that it relieves the base station from performing this task. In addition, the communication overhead that is required by having the base station instruct the CPE how to distribute its allocated bandwidth is eliminated. By using a combination of bandwidth allocation techniques, the present invention advantageously makes use of the efficiency benefits associated with each technique.

The base station media access control ("MAC") allocates available bandwidth on a physical channel on the uplink and the downlink. Within the uplink and downlink sub-frames, the base station MAC allocates the available bandwidth between the various services depending upon the priorities and rules imposed by their quality of service ("QoS"). The base station MAC maintains a set of queues for each physical channel that it serves. Within each physical channel queue set, the base station maintains a queue for each QoS. The queues hold data that is ready to be transmitted to the CPEs present on the physical channel. The base station higher MAC control layers are free to implement any convenient fairness or traffic shaping algorithms regarding the sharing of access between connections at the same QoS, without impacting the base station lower MAC control layers. In determining the amount of bandwidth to allocate at a particular QoS for a particular CPE, the base station takes into account the QoS, modulation,

and the fairness criteria used to keep an individual CPE from using up all available bandwidth. In one embodiment, the base station attempts to balance the uplink/downlink bandwidth allocations using an adaptive time-division duplexing technique (ATDD).

The uplink bandwidth allocation method is very similar to the downlink bandwidth allocation except that, rather than being maintained by the base station, the data queues are distributed across and maintained by each individual CPE. Rather than check the queue status directly, the base station preferably receives requests for bandwidth from the CPEs using the techniques described above.

BRIEF DESCRIPTION OF THE DRAWINGS

FIG. 1 shows a broadband wireless communication system adapted for use with the present invention.

FIG. 2 shows a TDD frame and multi-frame structure that can be used by the communication system of FIG. 1 in practicing the present invention.

FIG. 3 shows an example of a downlink sub-frame that can be used by the base stations to transmit information to the plurality of CPEs in the wireless communication of FIG. 1.

FIG. 4 shows an exemplary uplink sub-frame that is adapted for use with the present bandwidth allocation invention.

FIG. 5 is a flow diagram showing the information exchange sequence used in practicing the individual polling technique of the present invention.

FIG. 6 is a flow diagram showing the individual polling technique of the present invention.

FIG. 7 shows an exemplary uplink sub-frame map that is used to facilitate the present multicast/broadcast bandwidth allocation technique.

FIG. 8 is a flow diagram showing the multicast and broadcast polling technique of the present invention.

FIG. 9 is a flow diagram showing use of a "poll-me" to stimulate polling of a CPE in accordance with the present invention.

FIG. 10 shows the message sequence that is used by the present invention in requesting polls using the "poll-me" bit.

FIG. 11 is a flow diagram showing the bandwidth request piggybacking process of the present invention.

FIG. 12 shows the downlink bandwidth allocation method used by the present invention.

FIG. 13 shows the uplink bandwidth allocation method used by the present invention.

Like reference numbers and designations in the various drawings indicate like elements.

DETAILED DESCRIPTION OF THE INVENTION

Throughout this description, the preferred embodiment and examples shown should be considered as exemplars, rather than as limitations on the present invention.

The preferred embodiment of the present invention is a method and apparatus for allocating bandwidth in a broadband wireless communication system. One very important performance criterion of a broadband wireless communication system, and any communication system for that matter having a physical communication medium shared by a plurality of users, is how efficiently the system uses the physical medium. Because wireless communication systems are shared-medium communication networks, access and transmission by subscribers to the network must be controlled. In wireless communication systems a Media Access Control ("MAC") protocol typically controls user accesses to the

physical medium. The MAC determines when subscribers are allowed to transmit on the physical medium. In addition, if contentions are permitted, the MAC controls the contention process and resolves any collisions that occur.

In the system shown in FIG. 1, the MAC executed by software present in the base stations 106 (in some embodiments, the software may execute on processors both in the base stations and the CPE) control the transmission time for all of the CPEs 110. The base stations 106 receive requests for transmission rights and grant these requests within the time available taking into account the priorities, service types, quality of service and other factors associated with the CPEs 110. As described above in the background of the invention, the services provided by the CPEs 110 TDM information such as voice trunks from a PBX. At the other end of the service spectrum, the CPEs may uplink bursty yet delay-tolerant computer data for communication with the well-known World Wide Web or Internet.

The base station MAC maps and allocates bandwidth for both the uplink and downlink communication links. These maps are developed and maintained by the base station and are referred to as the Uplink Sub-frame Maps and Downlink Sub-frame Maps. The MAC must allocate sufficient bandwidth to accommodate the bandwidth requirements imposed by high priority constant bit rate (CBR) services such as T1, E1 and similar constant bit rate services. In addition, the MAC must allocate the remaining system bandwidth across the lower priority services such as Internet Protocol (IP) data services. The MAC distributes bandwidth among these lower priority services using various QoS dependent techniques such as fair-weighted queuing and round-robin queuing.

The downlink of the communication system shown in FIG. 1 operates on a point-to-multi-point basis (i.e., from the base station 106 to the plurality of CPEs 110). As described in U.S. Pat. No. 6,016,311, by Gilbert et al., issued Jan. 18, 2000, entitled "Adaptive Time Division Duplexing Method and Apparatus for Dynamic Bandwidth Allocation within a Wireless Communication System," the central base station 106 includes a sectored active antenna array 108 which is capable of simultaneously transmitting to several sectors. In one embodiment of the system 100, the active antenna array 108 transmits to six independent sectors simultaneously. Within a given frequency channel and antenna sector, all stations receive the same transmission. The base station is the only transmitter operating in the downlink direction, hence it transmits without having to coordinate with other base stations, except for the overall time-division duplexing that divides time into upstream (uplink) and downstream (downlink) transmission periods. The base station broadcasts to all of the CPEs in a sector (and frequency). The CPEs monitor the addresses in the received messages and retain only those addressed to them.

The CPEs 110 share the uplink on a demand basis that is controlled by the base station MAC. Depending upon the class of service utilized by a CPE, the base station may issue a selected CPE continuing rights to transmit on the uplink, or the right to transmit may be granted by a base station after receipt of a request from the CPE. In addition to individually addressed messages, messages may also be sent by the base station to multicast groups (control messages and video distribution are examples of multicast applications) as well as broadcast to all CPEs.

Within each sector, in accordance with the present invention, CPEs must adhere to a transmission protocol that minimizes contention between CPEs and enables the service to be tailored to the delay and bandwidth requirements of each user application. As described below in more detail, this transmis-

sion protocol is accomplished through the use of a polling mechanism, with contention procedures used as a backup mechanism should unusual conditions render the polling of all CPEs unfeasible in light of given delay and response-time constraints. Contention mechanisms can also be used to avoid individually polling CPEs that are inactive for long time periods. The polling techniques provided by the present inventive method and apparatus simplifies the access process and guarantees that service applications receive bandwidth allocation on a deterministic basis if required. In general, data service applications are relatively delay-tolerant. In contrast, real-time service applications such as voice and video services require that bandwidth allocations be made in a timely manner and in adherence to very tightly-controlled schedules. Frame Maps—Uplink and Downlink Sub-Frame Mappings

In one preferred embodiment of the present invention, the base stations **106** maintain sub-frame maps of the bandwidth allocated to the uplink and downlink communication links. As described in U.S. Pat. No. 6,016,311, by Gilbert et al., issued Jan. 18, 2000, entitled “Adaptive Time Division Duplexing Method and Apparatus for Dynamic Bandwidth Allocation within a Wireless Communication System,” the uplink and downlink are preferably multiplexed in a time-division duplex (or “TDD”) manner. In one embodiment, a frame is defined as comprising N consecutive time periods or time slots (where N remains constant). In accordance with this “frame-based” approach, the communication system dynamically configures the first N.sub.1 time slots (where N is greater than or equal to N.sub.1) for downlink transmissions only. The remaining N.sub.2 time slots are dynamically configured for uplink transmissions only (where N.sub.2 equals N-N.sub.1). Under this TDD frame-based scheme, the downlink sub-frame is preferably transmitted first and is prefixed with information that is necessary for frame synchronization.

FIG. 2 shows a TDD frame and multi-frame structure **200** that can be used by a communication system (such as that shown in FIG. 1) in practicing the present invention. As shown in FIG. 2, the TDD frame is subdivided into a plurality of physical slots (PS) **204**. In the embodiment shown in FIG. 2, the frame is one millisecond in duration and includes 800 physical slots. Alternatively, the present invention can be used with frames having longer or shorter duration and with more or fewer PSs. The available bandwidth is allocated by a base station in units of a certain pre-defined number of PSs. Some form of digital encoding, such as the well-known Reed-Solomon encoding method, is performed on the digital information over a pre-defined number of bit units referred to as information elements (PI). The modulation may vary within the frame and determines the number of PS (and therefore the amount of time) required to transmit a selected PI.

As described in U.S. Pat. No. 6,016,311, by Gilbert et al., issued Jan. 18, 2000, entitled “Adaptive Time Division Duplexing Method and Apparatus for Dynamic Bandwidth Allocation within a Wireless Communication System,” in one embodiment of the broadband wireless communication system shown in FIG. 1, the TDD framing is adaptive. That is, the number of PSs allocated to the downlink versus the uplink varies over time. The present bandwidth allocation method and apparatus can be used in both adaptive and fixed TDD systems using a frame and multi-frame structure similar to that shown in FIG. 2. As shown in FIG. 2, to aid periodic functions, multiple frames **202** are grouped into multi-frames **206**, and multiple multi-frames **206** are grouped into hyper-frames **208**. In one embodiment, each multi-frame **206** comprises two frames **202**, and each hyper-frame comprises twenty-two multi-frames **206**. Other frame, multi-frame and

hyper-frame structures can be used with the present invention. For example, in another embodiment of the present invention, each multi-frame **206** comprises sixteen frames **202**, and each hyper-frame comprises thirty-two multi-frames **206**. Exemplary downlink and uplink sub-frames used to in practicing the present invention are shown respectively in FIGS. 3 and 4.

Downlink Sub-Frame Map

FIG. 3 shows one example of a downlink sub-frame **300** that can be used by the base stations **106** to transmit information to the plurality of CPEs **110**. The base station preferably maintains a downlink sub-frame map that reflects the downlink bandwidth allocation. The downlink sub-frame **300** preferably comprises a frame control header **302**, a plurality of downlink data PSs **304** grouped by modulation type (e.g., PS **304** data modulated using a QAM-4 modulation scheme, PS **304'** data modulated using QAM-16, etc.) and possibly separated by associated modulation transition gaps (MTGs) **306** used to separate differently modulated data, and a transmit/receive transition gap **308**. In any selected downlink sub-frame any one or more of the differently modulated data blocks may be absent. In one embodiment, modulation transition gaps (MTGs) **306** are 0 PS in duration. As shown in FIG. 3, the frame control header **302** contains a preamble **310** used by the physical protocol layer (or PHY) for synchronization and equalization purposes. The frame control header **302** also includes control sections for both the PHY (**312**) and the MAC (**314**).

The downlink data PSs are used for transmitting data and control messages to the CPEs **110**. This data is preferably encoded (using a Reed-Solomon encoding scheme for example) and transmitted at the current operating modulation used by the selected CPE. Data is preferably transmitted in a pre-defined modulation sequence: such as QAM-4, followed by QAM-16, followed by QAM-64. The modulation transition gaps **306** contain preambles and are used to separate the modulations. The PHY Control portion **312** of the frame control header **302** preferably contains a broadcast message indicating the identity of the PS **304** at which the modulation scheme changes. Finally, as shown in FIG. 3, the Tx/Rx transition gap **308** separates the downlink sub-frame from the uplink sub-frame which is described in more detail below.

Uplink Sub-Frame Map

FIG. 4 shows one example of an uplink sub-frame **400** that is adapted for use with the present bandwidth allocation invention. In accordance with the present bandwidth allocation method and apparatus, the CPEs **110** (FIG. 1) use the uplink sub-frame **400** to transmit information (including bandwidth requests) to their associated base stations **106**. As shown in FIG. 4, there are three main classes of MAC control messages that are transmitted by the CPEs **110** during the uplink frame: (1) those that are transmitted in contention slots reserved for CPE registration (Registration Contention Slots **402**); (2) those that are transmitted in contention slots reserved for responses to multicast and broadcast polls for bandwidth allocation (Bandwidth Request Contention Slots **404**); and those that are transmitted in bandwidth specifically allocated to individual CPEs (CPE Scheduled Data Slots **406**).

The bandwidth allocated for contention slots (i.e., the contention slots **402** and **404**) is grouped together and is transmitted using a pre-determined modulation scheme. For example, in the embodiment shown in FIG. 4 the contention slots **402** and **404** are transmitted using a QAM-4 modulation. The remaining bandwidth is grouped by CPE. During its scheduled bandwidth, a CPE **110** transmits with a fixed modulation that is determined by the effects of environmental

factors on transmission between that CPE 110 and its associated base station 106. The downlink sub-frame 400 includes a plurality of CPE transition gaps (CTGs) 408 that serve a similar function to the modulation transition gaps (MTGs) 306 described above with reference to FIG. 3. That is, the CTGs 408 separate the transmissions from the various CPEs 110 during the uplink sub-frame. In one embodiment, the CTGs 408 are 2 physical slots in duration. A transmitting CPE preferably transmits a 1 PS preamble during the second PS of the CTG 408 thereby allowing the base station to synchronize to the new CPE 110. Multiple CPEs 110 may transmit in the registration contention period simultaneously resulting in collisions. When a collision occurs the base station may not respond.

By using the bandwidth allocation method and apparatus of the present invention, scheduled uplink traffic data is bandwidth allocated to specific CPEs 110 for the transmission of control messages and services data. The CPE scheduled data is ordered within the uplink sub-frame 400 based upon the modulation scheme used by the CPEs 110. In accordance with the present invention and in the manner described in detail below, bandwidth is requested by a CPE 110 and is subsequently granted by an associated base station 106. All of the bandwidth allocated to a selected CPE within a given TDD frame (or alternatively an adaptive TDD frame, as the case may be) is grouped into a contiguous CPE scheduled data block 406. The physical slots allocated for the CTGs 408 are included in the bandwidth allocation to a selected CPE 110 in the base station uplink sub-frame map.

In addition to the bandwidth that is allocated for the transmission of the various types of broadband services (i.e., the bandwidth allocated for the CPE scheduled data slots 406), and the bandwidth allocated for CPE registration contention slots, bandwidth must also be allocated by the base station MAC for control messages such as requests for additional bandwidth allocations. As described in more detail below, in accordance with the present invention, CPEs 110 request changes to their bandwidth allocations by making bandwidth requests of their associated base stations 106. The present inventive method and apparatus reduces the amount of bandwidth that must be set aside for these bandwidth allocation requests. In accordance with the present invention, the opportunities for requesting bandwidth are very tightly controlled. The present invention advantageously utilizes a combination of a number of techniques to tightly control the bandwidth request process. There are a number of means by which a CPE can transmit a bandwidth request message to its associated base station.

For example, one such means uses a “polling” technique whereby a base station polls one or more CPEs and allocates bandwidth specifically for the purpose of allowing the CPE(s) to transmit bandwidth requests. In accordance with this method, the polling of CPEs by the base station may be in response to a CPE setting a “poll-me bit” in an upstream direction or it may be periodic. In accordance with the present invention, periodic polls may be made to individual CPEs (referred to as “reservation-based” polling), to groups of CPEs (“multicast” polling), or to every CPE on a physical channel (“broadcast” polling). In reservation-based polling, the base station polls an individual CPE and then allocates uplink bandwidth to allow the CPE to respond with a bandwidth request. Similarly, in multicast and broadcast polling, the base station polls several CPEs and then allocates uplink bandwidth to allow the CPEs to respond with a bandwidth request. However, the CPEs must contend for the allocated bandwidth if collisions occur. Advantageously, neither the bandwidth polls nor the bandwidth allocations are in the form

of explicit messages that are communicated by the base station to the CPEs. Rather, the bandwidth polls comprise unsolicited grants of bandwidth sufficient for transmitting bandwidth requests. Bandwidth allocations are implicit via bandwidth allocations occurring in the uplink sub-frame map. The polling techniques are described in more detail below with reference to FIGS. 4-10.

As shown in FIG. 4, a portion of the uplink bandwidth may periodically be allocated for these bandwidth allocation or CPE connection requests. The uplink sub-frame 400 includes a plurality of bandwidth request contention slots 404. A CPE 110 must first be registered and achieve uplink synchronization with a base station before it is allowed to request bandwidth allocation. Therefore there is no need to allow for transmit time uncertainties in the length of the bandwidth request contention period. Consequently the bandwidth request contention period may be as small as a single PI, which, in one embodiment, at QAM-4 requires 6 PS. As with the registration requests, if a collision occurs, the base station may not respond to the CPE. If, however, the base station successfully receives a bandwidth request message from a CPE, it responds by allocating the CPE additional scheduled data 406 bandwidth in the uplink sub-frame 400. The various polling techniques used by the present invention help to minimize the need to use the contention slots 404. These techniques are described in more detail below.

Another means used by the present invention in reducing the bandwidth consumed by the bandwidth request messages is the technique of “piggybacking” bandwidth requests on bandwidth already allocated to a CPE. In accordance with this technique, currently active CPEs request bandwidth using previously unused portions of uplink bandwidth that is already allocated to the CPE. The necessity of polling CPEs is thereby eliminated. In an alternative embodiment of the present invention, bandwidth requests are piggybacked on uplink bandwidth allocated and actively being used by a data service. In accordance with this alternative, the CPE “steals” bandwidth already allocated for a data connection by inserting bandwidth requests in time slots previously used for data. The details of these piggybacking techniques are described in more detail below with reference to FIG. 11.

Once a CPE is allocated bandwidth by the base station, the CPE, not the base station, is responsible for using the uplink bandwidth in a manner that can accommodate the services provided by the CPE. The CPE is free to use the uplink bandwidth that was allocated to it in a manner that is different than originally requested or granted by the base station. For example, the service requirements presented to a selected CPE can change after the selected CPE requests bandwidth from its associated base station. The CPE advantageously determines which services to give bandwidth to and which services must wait for subsequent bandwidth requests. To this end, the CPE maintains a priority list of services. Those services having higher priority (e.g., those services having high quality of service demands) will be allocated bandwidth before those services having lower priority (e.g., IP-type data services). If the CPE does not have sufficient bandwidth to meet its service requirements, the CPE will request additional bandwidth allocations by either setting its poll-me bit or by piggybacking a bandwidth allocation request.

One advantage of having the CPE determine how to distribute its allocated bandwidth is that it relieves the base station from performing this task. In addition, the communication overhead that is required by having the base station instruct the CPE how to distribute its allocated bandwidth is thereby eliminated, thus increasing usable system bandwidth. In addition, the CPE is in a much better position to respond to

the varying uplink bandwidth allocation needs of high quality of service data services. Therefore, the CPE can better accommodate the needs of these types of service requirements than can the base station.

The various techniques used by the present invention to enhance the efficiency of the bandwidth allocation request process are described in more detail below in the sub-sections that follow. Although these techniques are described in separate sub-sections, the present inventive method and apparatus advantageously uses all of the techniques in combination to reduce the bandwidth consumed by the bandwidth allocation requests.

Thus, the present invention advantageously makes use of the efficiency benefits associated with each bandwidth allocation technique. For example, although an individual polling technique is beneficial with regard to the ability to provide fast response times to bandwidth allocation requests, it is relatively inefficient with regard to the amount of bandwidth consumed by the bandwidth allocation process. In contrast, the group polling method is relatively efficient with regard to the bandwidth consumed by the bandwidth allocation process, but it is less efficient with regard to the ability to respond to bandwidth allocation requests. Use of a "poll-me" bit is relatively efficient when considered from both the bandwidth consumption and response time perspectives. In addition, the piggybacking technique further enhances bandwidth consumption efficiency by using previously unused portions of the bandwidth to send the bandwidth allocation requests. In contrast to the prior art approaches, the present invention advantageously uses all of these bandwidth allocation techniques in combination to maximize efficiency.

Polling

In one embodiment of the broadband wireless system **100** of FIG. **1** designed for use with the present invention, a CPE **110** is assigned a dedicated connection identifier (ID) when the CPE **110** first registers with the system **100**. The ID is used when the base station **106** exchanges control messages with the plurality of CPEs **110**. As described above, variations in bandwidth requirements (i.e., increases or decreases to bandwidth requirements) are necessary for all services transported by the system **100** with the exception of uncompressible constant bit rate, or continuous grant (CG) services. The bandwidth requirements of uncompressible CG services do not change between connection establishment and termination. The requirements of compressible CG services, such as channelized-T1 services, may increase or decrease depending on traffic.

In contrast, many of the data services facilitated by the system **100** of FIG. **1** are bursty and delay-tolerant. Because bandwidth is provided to these services on a demand assignment basis as needed these services are commonly referred to as Demand-Assigned Multiple Access or "DAMA" services. When a CPE **110** needs to request bandwidth for a DAMA service it transmits a bandwidth request message to the base station **106**. The bandwidth request messages communicate the immediate bandwidth requirements for the DAMA service. The bandwidth requirements can and typically do vary over time. The quality of service or "QoS" for the DAMA connection is established when the CPE connection is initially established with the base station. Therefore, the base station has the ability to access or "look-up" the QoS for any DAMA service that it is currently accommodating.

As described above, in accordance with the present invention, the CPEs **110** have a number of different techniques available to them for communicating bandwidth request messages to their associated base stations. One such technique is by transmitting a bandwidth request message in response to

being polled by a base station. In accordance with the polling technique taught by the present invention, the base station allocates bandwidth to selected CPEs specifically for the purpose of making bandwidth requests. The bandwidth allocations may be to individual CPEs or to groups of CPEs. As described in more detail below in the sub-section that describes the group polling technique, allocations to groups of CPEs define bandwidth request contention slots that are used in resolving bandwidth request collisions. Advantageously, the bandwidth allocations are not made in the form of explicit messages, but rather they are made in the form of bandwidth allocation increases in the transmitted map describing the uplink sub-frame **400** (FIG. **4**). Polling is performed on a per-CPE basis, bandwidth is requested on a per-connection-ID basis, and bandwidth is allocated on a per-CPE basis. These concepts are described in more detail below.

Reservation-Based Polling Technique (Individual Polling)

In accordance with the present inventive method and apparatus, when a CPE is polled individually, no explicit message is transmitted to poll the selected CPE. Rather, the CPE is allocated bandwidth in the uplink sub-frame map that is sufficient to allow the CPE to respond with the bandwidth request. Specifically, the base station allocates bandwidth in the CPE scheduled data block **406** (FIG. **4**) for the selected CPE that is sufficient to allow the selected CPE to respond with a bandwidth request message. If the selected CPE does not require more bandwidth, it returns a request for zero bytes. A zero byte request (rather than no request) is used in the individual polling process because explicit bandwidth for a reply is allocated.

In accordance with the present invention, only inactive CPEs and active CPEs that explicitly request to be polled are eligible for individual polling. Active CPEs that do not set their respective "poll-me" bits in the MAC packet header will not be polled individually. These restrictions are imposed upon the bandwidth request process by the present invention and they advantageously save bandwidth compared with polling all of the CPEs individually. In one embodiment of the present invention, active CPEs respond to polling using the modulation scheme currently in use. However, inactive CPEs may respond using a QAM-4 or similarly robust modulation scheme to ensure that their transmission is sufficiently robust to be detected by the base station even under adverse environmental conditions.

The present invention advantageously ensures timely responses to requests for more bandwidth for a constant bit rate service such as a channelized T1 service in which channels may be added or dropped dynamically. To ensure that the base station responds quickly to requests for more bandwidth for a constant bit rate service, the uplink bandwidth allocated to a constant bit rate service that is not currently operating at a maximum rate is made sufficiently large to accommodate the service's current rate and a bandwidth request.

The information exchange sequence for individual polling is shown in the flow diagram of FIG. **5**. As shown in FIG. **5**, the base station preferably has several layers of control mechanisms or protocol stacks **502**, **504** and **506** that control, among other things, the bandwidth request and allocation process. The base station MAC is sub-divided into two sub-domains: (1) the HL-MAA MAC domain **504** and the LL-MAA Mac domain **506**. The LL-MAA MAC domain spans exactly a physical channel. Each physical channel requires an instance of the LL-MAA MAC domain. The HL-MAA MAC domain spans multiple physical channels, typically all in the same sector. A MAC domain comprises an HL-MAA MAC

domain and the LL-MAA MAC domains associated with the physical channels within the HL-MAA MAC domain.

As shown in FIG. 5, the base station individually polls (as indicated by control arrow 508) a CPE by allocating bandwidth sufficient for the CPE to respond with a bandwidth request message. This bandwidth is allocated in the uplink sub-frame 400. If the CPE MAC 510 determines that there is data to be sent for a selected connection k (typically determined by being instructed by a higher CPE control layer 512 via a control path 514), then the CPE MAC control mechanism issues a bandwidth request 516 to the base station MAC 506. If there is insufficient bandwidth available to the CPE 110 as determined by the base station's LL-MAA 506, the bandwidth request will not be granted. Else, the bandwidth request will be granted and this will be implicitly communicated to the CPE MAC 510 by the base station allocating additional bandwidth to the CPE in the uplink sub-frame 400. This is shown in FIG. 5 via the control path 518. The CPE will then begin transmitting data to the base station over the uplink using the bandwidth that has been allocated to it.

FIG. 6 is a flow diagram showing the individual polling technique 600 provided by the present invention. As shown in FIG. 6, the method starts at decision STEP 602 to determine whether bandwidth is available for the purpose of individually polling the CPEs. If no more bandwidth is available for individually polling the CPEs 110 then the method proceeds to STEP 604 and initiates a multicast or broadcast polling method. This multicast and broadcast polling method is described in detail in the sub-section below. However, if sufficient bandwidth is available for the purpose of individually polling CPEs, the method proceeds to a decision STEP 606 whereat a determination is made whether there are any un-pollled active CPEs that have a "poll-me" bit set. If so, the method proceeds to a control point 608. If not, the method proceeds to a decision STEP 610 whereat it determines whether there are any un-pollled inactive CPEs present. If so, the method proceeds to the control point 608. If not, the method proceeds to a control point 612.

The present inventive method proceeds from the control point 608 to STEP 614 to individually poll the selected CPE. Thus, the method ensures that only un-pollled active CPEs requesting more bandwidth (by setting their respective "poll-me" bits) and inactive CPEs are individually polled. This reduces bandwidth as compared with a polling method that would individually poll all CPEs.

As shown in FIG. 6, at STEP 614 the base station initiates the polling of the selected CPE and marks the CPE as polled. This is shown diagrammatically in FIG. 6 in the caption box 614'. The caption box 614' of FIG. 6 shows the downlink sub-frame map 300 described above in FIG. 3. The MAC control portion 314 of the MAC frame control header 302 preferably includes an uplink sub-frame map 400'. The uplink sub-frame map 400' is communicated to the CPE MAC when the base station transmits this information to the CPE via the downlink. As shown in FIG. 6, and responsive to the polling STEP 614, the base station MAC allocates additional bandwidth to the selected CPE (in FIG. 6 this CPE is referred to as CPE "k") in the uplink. This increased bandwidth allocation is communicated to the CPE k via the uplink sub-frame map 400'. Thus, no additional bandwidth is needed to respond to the need to poll the selected CPE.

As shown in FIG. 6, the method then returns to the decision STEP 602 to determine whether there is more bandwidth available for individually polling the CPEs. When it is determined (at the decision STEPS 606 and 610, respectively) that there are no active CPEs having a poll-me bit set and that there are no un-pollled inactive CPEs present, the method proceeds

to a decision STEP 616. At the decision STEP 616, the method determines whether any individual polls were performed. If not, the method proceeds to a control point 618 and the method subsequently terminates at the termination step 620. However, if individual polls were performed, the method proceeds to a STEP 622 to await the individual bandwidth requests from the CPE that was polled (e.g., CPE "k"). As shown in the caption 622' of FIG. 6, this bandwidth request 430 is generated by the polled CPE (e.g., CPE "k") during the CPE scheduled data block 406 scheduled for the selected CPE in the uplink sub-frame 400. In one embodiment, all data includes a header that indicates the type of data being transmitted. For example, in this embodiment, control messages have associated CPE-unique connection identifiers that are assigned to them when the CPE registers. The structure of the control messages allows a base station to determine that a control message is a bandwidth request.

As shown in FIG. 6, the method proceeds from STEP 622 to a decision STEP 624 to determine whether any bandwidth requests were received. If not, the method terminates. However, if so, the method proceeds to a STEP 626 whereat a bandwidth allocation method is initiated. As described in more detail below, the base station uses a preferred bandwidth allocation method to allocate bandwidth to the requesting CPE. The bandwidth allocation is indicated to the CPE by making appropriate changes to the uplink sub-frame map 400'. The method then terminates at STEP 620.

Contention-Based Polling Technique (Multicast and Broadcast Polling)

As described above with reference to STEP 604 of the individual polling method of FIG. 6, if there is not sufficient bandwidth available for the purpose of individually polling the CPEs, the present invention may be used to poll the CPEs in multicast groups and a broadcast poll may be issued by the base station. Also, if there are more inactive CPEs than there is bandwidth available to individually poll them, some CPEs may be polled in multicast groups and a broadcast poll may be issued.

In accordance with one embodiment of the invention, the addressing of CPEs is preferably performed as follows: each CPE is assigned a unique permanent address (e.g., in one embodiment the CPE has a 48-bit address) that is used in the registration process; and each CPE is also given a basic connection ID (e.g., in one embodiment the CPE is given a 16-bit basic connection ID and a 16-bit control connection ID during the registration process). Each service that is provisioned for a selected CPE is also assigned a connection ID. Connection IDs are generated by the base station MAC (specifically, by the base station HL-MAA) and are unique across an HL-MAA MAC domain. The basic connection ID that is assigned when the CPE is registered with a base station is used by the base station MAC and the CPE MAC to exchange MAC control messages between the CPE and the base station. The control connection ID (also assigned during registration) is used by the base station and the CPE to exchange control and configuration information between the base station and the CPE higher levels of control.

In accordance with one embodiment of the present invention, certain connection IDs are reserved for multicast groups and broadcast messages. Of all of the addresses available a portion of them are preferably reserved for multicast use. For example, in one embodiment of the present invention, if the four most-significant bits of the connection ID are set to logical ones (hex "Fxxx") the address is interpreted as being set aside for multicast use. In this embodiment, a total of 4K distinct multicast addresses are available. One example of such a multicast use is for the distribution of a video service.

In one preferred embodiment, the connection ID used to indicate a broadcast to all stations is (0xFFFF) (i.e., all 16 bits are set to a logical one).

Similar to the individual polling technique described above with reference to FIGS. 5 and 6, the multicast polling message is not explicitly transmitted by the base station to the CPE. Rather, the multicast poll message is implicitly transmitted to the CPE when the base station allocates bandwidth in the uplink sub-frame map. However, rather than associating allocated bandwidth with a CPE's basic connection ID as done when performing an individual poll, the base station associates the allocated bandwidth to a multicast or broadcast connection ID. This multicast/broadcast bandwidth allocation is shown in the multicast/broadcast uplink sub-frame map **400**" shown in FIG. 7. It is instructive to compare the uplink sub-frame **400** (FIG. 4) used by the base station when individual polling the CPEs with the uplink sub-frame map **400**" of FIG. 7. FIG. 7 shows the uplink sub-frame map which is transmitted in the MAC control portion of the downlink.

As shown in FIG. 7, the multicast/broadcast uplink sub-frame map **400**" used by the present invention includes registration contention slots **402**" that map the registration contention slots **402** of FIG. 4. However, rather than associating allocated bandwidth with a selected CPE's basic connection ID, the allocated bandwidth is associated with a reserved registration ID. As shown in FIG. 7, the uplink sub-frame map **400**" preferably includes a plurality of multicast group bandwidth request contention slots **404**", **404**", etc. The uplink sub-frame map **400**" also includes broadcast bandwidth request contention slots **410**. Finally, similar to the uplink sub-frame of FIG. 4, the uplink sub-frame map used by the present invention to initiate multicast or broadcast polls includes a plurality of CPE scheduled data blocks **406**", **406**", etc., that are used to transport uplink traffic data.

In accordance with the present inventive method and apparatus, when a poll is directed to a multicast or broadcast connection ID, CPEs belonging to the polled group request bandwidth using the bandwidth request contention slots (either the multicast contention slots for the group specified or the broadcast bandwidth request contention slots **410**) allocated in the uplink sub-frame map **400**". In order to reduce the likelihood of collisions only CPE's needing bandwidth are allowed to reply to multicast or broadcast polls. Zero-length bandwidth requests are not allowed in the bandwidth request contention slots. In one embodiment, CPEs transmit the bandwidth requests in the bandwidth request contention slots (e.g., contention slots **404**) using QAM-4 modulation. In this embodiment, the contention slots are sized to hold a 1-PS preamble and a bandwidth request message. Due to physical resolution characteristics, the message requires 1 PI (or 6 PS) using QAM-4 modulation. In this embodiment, multiple bandwidth request messages from the same CPE fit in a single bandwidth request contention slot without increasing the bandwidth utilization or the likelihood of collisions occurring. This allows the same CPE to make multiple bandwidth requests in the same slot.

If an error occurs when performing either a multicast or broadcast poll (such as the detection of an invalid connection ID) the base station transmits an explicit error message to the CPE. If the base station does not respond with either an error message or a bandwidth allocation within a predefined time period, the CPE will assume that a collision occurred. In this case the CPE uses a selected pre-defined contention resolution process. For example, in one preferred embodiment, the CPE uses the well-known "slotted ALOHA" contention resolution process to back off and try at another contention opportunity.

Contention Resolution Process

Contention is necessary when there is insufficient time to poll all of the CPEs individually within a suitable interval. The base station is able to define contention periods both for multicast groups and also for all CPEs generally (i.e., broadcast). After CPE scheduled data, control messages, and polling are allowed for, the base station allocates all unused time in the upstream part of the TDD frame to contention, either for bandwidth requests or for registration purposes. Typically the bandwidth request interval will be many PIs long (e.g., 1 PI=6 PS using QAM-4 modulation). The CPEs must transmit their requests at a random time (on burst boundaries) within this interval to reduce the likelihood of collisions occurring.

In accordance with the present invention, a CPE needing to transmit in a request interval preferably randomly selects a PI within the interval, and makes a request in the associated starting PS. This randomization minimizes the probability of collisions. A collision is presumed if there is no response from the base station to the request within a pre-defined time period. If the base station does not respond within the pre-defined time period the collision resolution process of the present invention is initiated.

One preferred embodiment of the present invention uses the following resolution process: Assuming that the initial backoff parameter is i and that the final backoff parameter is f ,

1. On the first collision, the CPE waits a random interval between zero and $2 \cdot \text{sup}.i$ contention opportunities and then tries again.

2. If another collision occurs, then the interval is doubled and the CPE tries again, repeating until the interval $2 \cdot \text{sup}.f$ is reached.

If the CPE is still unsuccessful, an error is reported to the system controller and the contention process is aborted. Other contention resolution mechanisms can be used to practice the present invention. For example, the well-known Ternary tree mechanism could be used to resolve contentions.

FIG. 8 is a flowchart showing the multicast and broadcast polling method **800** of the present invention. As shown in FIG. 8, the group polling method **800** proceeds from an initial step **802** to a decision STEP **804** whereat the method determines whether there is sufficient bandwidth available for multicast polls. If sufficient bandwidth is available for multicast polls, the method proceeds to a STEP **806** to poll the next multicast group in the MAC control portion **314** of the MAC frame control header **302**. However, if there is insufficient bandwidth available to perform a multicast poll, the method proceeds to a decision STEP **808** whereat the method determines whether there is sufficient available bandwidth for performing a broadcast poll. If so, the method proceeds to a STEP **810**. If not, the method proceeds to a decision STEP **812**.

As shown in FIG. 8, at the STEP **810** a broadcast poll is initiated by placing the broadcast poll in the MAC control portion **314** of the MAC frame control header **302**. Similar to the individual polling technique, the multicast poll message is implicitly transmitted to the CPE by allocating bandwidth in the uplink sub-frame map **400**". The allocated bandwidth is associated with a multicast or broadcast connection ID.

At the decision STEP **812** the method determines whether a broadcast or multicast poll was initiated. If so, the method proceeds to a STEP **814** whereat the method monitors the appropriate bandwidth request contention slots (e.g., as defined by the bandwidth contention slot descriptions **404**", **404**", and the broadcast bandwidth request contention slot descriptions **410** of FIG. 7). If no broadcast or multicast poll

was initiated, the method proceeds to control point **816** and subsequently terminates at a termination STEP **818**.

The method proceeds from the monitoring STEP **814** to a decision STEP **820** to determine whether valid (i.e., non-colliding) bandwidth requests were detected. If no valid bandwidth requests were detected at STEP **820**, the method proceeds to the control point **816** and terminates at termination STEP **818**. However, if the method detects valid bandwidth requests, the method proceeds from STEP **820** to STEP **822**. At STEP **822** the method uses a convenient bandwidth allocation algorithm to allocate bandwidth to the CPE that requested bandwidth. The preferred bandwidth allocation algorithm is described below in more detail with reference to FIGS. **12-13**. The bandwidth is allocated in the uplink sub-frame map **400** as shown in FIG. **8**.

Poll-Me Bit

As described above with reference to FIGS. **3-8**, and in accordance with the present invention, a currently active CPE sets a “poll-me” bit or a “priority poll-me” in a MAC packet in order to indicate to the base station that it requires a change in bandwidth allocation. For example, in one embodiment of the present invention, a selected CPE requests a poll by setting a poll-me (“PM”) bit in the MAC header. Similarly, in accordance with the present invention, a selected CPE sets a priority poll-me (“PPM”) bit in the MAC header in order to indicate that a priority poll is desired.

In order to reduce the bandwidth requirements associated with individually polling every active CPE, the active CPEs are individually polled if and only if one of the poll-me bits is set by the CPE. When the base station detects a request for polling (when the CPE sets its poll-me bit), the individual polling technique shown in FIG. **9** is activated in order to satisfy the request. The procedure by which a CPE stimulates a base station to poll the CPE is shown in FIG. **9**. In an alternative embodiment, multiple packets having “poll-me” bits set indicate that the CPE needs to make bandwidth allocation requests for multiple connections.

FIG. **9** is a flow chart that shows how the poll-me bit is used to stimulate polling in accordance with the present invention. As shown in FIG. **9**, the method first determines at a decision STEP **902** whether the piggybacking technique described in more detail below has been exhausted. If not, the method proceeds to STEP **904** and attempts to perform “piggybacking” first. The method then proceeds to a STEP **906** whereat the connection is set equal to a first connection. In this manner, the poll-me bits are scanned for each connection within the CPE. The method shown in FIG. **9** then proceeds to a decision STEP **908** to determine whether any bandwidth needs exist. If not, the method proceeds to a STEP **916** and scans for the next connection. If a bandwidth need exists, the method proceeds to a decision STEP **910**. At STEP **910** the method determines whether any more packets are available for accommodating the poll-me bit. If not, the method terminates at the STEP **910**. However, if packets are available, the method proceeds to a STEP **912** and sets a poll-me bit in an available packet.

FIG. **10** shows the message sequence that is used by the present invention in requesting polls using the “poll-me” bit described above. As shown in FIG. **10** at data connection **930**, the CPE initiates a polling sequence by setting its associated poll-me bit in the MAC header. The base station MAC responds via data message **932** by individually polling the selected CPE. This response is made by allocating bandwidth to the selected CPE in the uplink sub-frame map as shown in FIG. **10**. The selected CPE subsequently responds with a bandwidth request as shown in communication path **934**. In response to the CPE’s bandwidth request, the base station

grants bandwidth and allocates bandwidth to the CPE in the uplink sub-frame map as shown in communication path **936**. The selected CPE then transmits its data to the base station via an associated connection link.

“Piggybacking” Technique

As described above with reference to the present inventive method and apparatus, in order to further reduce overhead bandwidth necessary for the bandwidth allocation process, currently active CPEs may “piggyback” a bandwidth request (or any other control message) on their current transmissions. The CPEs accomplish this piggybacking of bandwidth by using unused bandwidth in TC/PHY packets of existing bandwidth allocations. The procedure for using excess bandwidth in this manner is shown in FIG. **11**.

As shown in FIG. **11**, the method initiates the piggybacking process at STEP **950**. The method proceeds to a decision STEP **952** to determine whether the CPE requires additional bandwidth. If so, the method proceeds to a decision STEP **954**, if not, the method proceeds to a termination STEP **964** whereat the method terminates. At the decision STEP **954** the method determines whether any unused bytes exist in the current allocation. If so, the method proceeds to insert bandwidth requests into the unused bytes at STEP **956**. If not, the method proceeds to a decision STEP **958**. At the decision STEP **958**, the method determines whether any packets at all are allocated to the CPE. If there are no packets found at the decision STEP **958**, the method proceeds to STEP **960**. However, if packets are allocated, the method proceeds to a STEP **962** whereat the CPE sets its poll-me bit. The method then proceeds to the STEP **960** whereat the CPE awaits polling by the associated base station. The method then terminates at the STEP **964**.

Bandwidth Allocation

As described above, the base station MAC is responsible for allocating the available bandwidth of a physical channel on the uplink and the downlink. Within the uplink and downlink sub-frames, the base station MAC scheduler allocates the available bandwidth between the various services depending upon the priorities and rules imposed by their quality of service (QoS). Additionally, the higher control sub-layers of the base station MAC allocate across more than one physical channel.

Down link Bandwidth Allocation—One Embodiment

The downlink bandwidth is allocated as shown in FIG. **12**. The base station MAC maintains a set of queues for each physical channel that it serves. Within each physical channel queue set, the base station maintains a queue for each QoS. The queues hold data that is ready to be transmitted to the CPEs present on the physical channel. The higher layers of the base station protocol stack are responsible for the order in which data is placed in the individual queues. The base station higher control layers are free to implement any convenient fairness or traffic shaping algorithms regarding the sharing of access between connections at the same QoS, without impacting the base station lower MAC control layers. Once data is present in the queues it is the responsibility of the base station lower levels of control (e.g., the BS LL-MAA of FIGS. **5** and **10**) to allocate bandwidth based on the QoS.

In one embodiment of the present invention, in determining the amount of bandwidth to allocate at a particular QoS for a particular CPE, the base station takes into account the QoS, modulation, and the fairness criteria used to keep an individual CPE from using up all available bandwidth. Bandwidth is preferably allocated in QoS order. If there is a queue that cannot be transmitted entirely within a particular TDD frame, a QoS specific fairness algorithm, such as fair-weighted queuing, is used within that queue. Each connection

is given a portion of the remaining available bandwidth based upon its relative weight. The derivation of weights is QoS-dependant. For example, ATM traffic may be weighted based upon contractual bandwidth limits or guarantees, while IP connections may all receive identical weights. Once the bandwidth is allocated the data is transmitted in a manner whereby the data is sorted by modulation type.

Uplink Bandwidth Allocation—One Embodiment

The uplink bandwidth allocation method is very similar to the downlink bandwidth allocation method described above with reference to FIG. 12. However, rather than being maintained by the base station, the data queues are distributed across and maintained by each individual CPE. Rather than check the queue status directly, the base station preferably receives requests for bandwidth from the CPEs using the techniques described above with reference to FIGS. 3-11. Using these bandwidth requests, the base station reconstructs a logical picture of the state of the CPE data queues. Based on this logical view of the set of queues, the base station allocates uplink bandwidth in the same way as it allocates downlink bandwidth. This uplink bandwidth allocation technique is shown in FIG. 13.

As described above, the bandwidth allocated to any selected CPE is transmitted to the selected CPE in the form of bandwidth being allocated in the uplink sub-frame map. Starting at a point in the TDD, the uplink sub-frame map allocates a certain amount of bandwidth to the selected CPE. The selected CPE then allocates this bandwidth across its connections. This allows the CPE to use the bandwidth in a different manner than requested if it receives higher priority data while awaiting the bandwidth allocation. As described above, the bandwidth allocations are in a constant state of change owing to the dynamic nature of bandwidth requirements. Consequently, a selected CPE may receive unsolicited modifications to the bandwidth granted on a frame-by-frame basis. If the selected CPE is allocated less bandwidth for a frame than is necessary to transmit all waiting data, the CPE must use the QoSs and fairness algorithms to service its queues. The CPE may “steal” bandwidth from lower QoS connections to piggyback request for more bandwidth using the piggybacking technique described above. TDM connections not already at maximum bandwidth are allocated enough extra bandwidth in the uplink to piggyback a request for additional bandwidth.

QoS Specific Fairness Algorithms

Data for transmission on the uplink and the, downlink is preferably queued by quality of service (QoS) designations. The data is transmitted in order of a QoS queue priority as described above. As the queued data is transmitted, there may be a QoS queue for which there is insufficient bandwidth to transmit all queued data during the current TDD frame. When this situation occurs, a QoS specific fairness algorithm is initiated to ensure fair handling of the data queued at that QoS. There are 3 basic fairness algorithms that can be implemented: (1) Continuous Grant; (2) Fair-weighted queuing; and (3) Round Robin.

The MAC preferably does not police connections for bandwidth usage. Policing should be performed by higher control layers. The MAC assumes that all pending data has met contractual restrictions and can be transmitted. Continuous Grant queues have the simplest fairness algorithm. All data in these queues must be sent every TDD frame. Insufficient bandwidth indicates an error in provisioning.

Fair Weighted Queuing

Fair weighted queuing requires that all connections at a given QoS have a weight, assigned to them to determine the percentage of the available bandwidth they are eligible to

receive. This weight value is preferably derived from one of three data rate parameters, depending upon the contractual parameters of the provisioned connection. These three parameters are: (1) Data Pending; (2) Guaranteed Rate; and (3) Average Rate.

Real-time VBR connections are established as DAMA connections with fair-weighted queuing based upon data pending. For a QoS queue of this type in a TDD frame having insufficient bandwidth to transmit all of the data in the queue, a weight for each connection in the queue is determined. In one embodiment, this weight is the amount of data pending for the connection expressed as a percentage of the total data pending in the queue. Because the amount of data pending is dynamic, the weights for these types of queues must be determined every TDD frame where there is insufficient bandwidth to send all data in the affected queue.

For DAMA connections contracted at a guaranteed rate the weights are calculated based on the guaranteed rate. In this case, the weight preferably is expressed as a percentage of the total guaranteed rate of all connections with data pending in the queue. Because the guaranteed rate is provisioned the weights need not be determined each TDD frame where they are used. Rather, the weights for a queue are only determined when there is a provisioning change (i.e., a new connection, a change in connection parameters, or a connection termination) for one of the connections in the queue.

For DAMA connections contracted at an average rate the weights are preferably calculated based on the average rate. The weight is the average rate expressed as a percentage of the total average rate of all connections with data pending in the queue. Because the average rate is provisioned the weights need not be determined each TDD frame where they are used. Rather, the weights for a queue are only recalculated when there is a provisioning change for one of the connections in the queue.

In all of the cases described above, the granularity of the bandwidth allocations may be too coarse to provide a perfect percentage-based weighted allocation across the connections in the queue. This may result in some queues not receiving any bandwidth in a particular TDD frame. To ensure that the occurrence of this condition is fairly distributed across the connections in the queue, the connection that did not receive bandwidth is given priority the next time the insufficient bandwidth condition exists for the queue. For queues with weights based upon guaranteed or average rates some connections may not have sufficient data pending to use all of the bandwidth that they are entitled to based upon their calculated weight. In these cases, the connection’s unused bandwidth is fairly distributed across the connections having excess data pending.

Some QoSs require that data be aged. For queues at these QoSs there is an associated queue of one step higher priority. If data is not transmitted by the provisioned aging parameter, the data is moved to the higher QoS queue and given priority over newer data in the original queue regardless of the relative weights of the connections.

Round Robin

The Round Robin fairness algorithm is used for best effort connections where all connections have equal weight. When insufficient bandwidth exists to transmit all data in the queue in a particular TDD frame connections are allocated bandwidth in a round-robin fashion with each connection receiving a block of bandwidth up to a queue-specific maximum. Connections that did not receive bandwidth are given priority the next time the insufficient bandwidth condition exists.

Bandwidth Allocation Algorithm

For each TDD frame, the base station allocates the downlink portion of the TDD frame and it performs an estimate of the uplink traffic to allocate uplink bandwidth to the CPEs. The CPEs individually allocate their allotted bandwidth across their pending data connections.

Base Station Downlink

As shown in FIG. 2, in one preferred embodiment of the present invention, based on the ATDD split (i.e., the percentage of bandwidth allocated to the uplink and downlink) the base station has some number of the 800 PS in the TDD frame available for downlink transmissions. The downlink bandwidth allocation algorithm preferably proceeds as follows.

First, the base station allocates PSs to the PI for PHY Control and enough PSs for at least 1 PI for the MAC Control. For each remaining QoS, or until available bandwidth is entirely allocated, the CPE determines if there is bandwidth sufficient to satisfy the entire need of the QoS queue. If so, the CPE allocates the required bandwidth. Otherwise, if there is not bandwidth sufficient to satisfy the queue, the CPE implements the queue-specific fairness algorithm described above.

For connections with downlink continuous grant data pending, the base station determines the number of PIs required to transmit the data. This number is then converted to PSs as a function of the modulation used for the CPE associated with each connection. For each remaining QoS or until available bandwidth is entirely allocated, the base station determines if there is enough bandwidth to satisfy the entire need of the QoS queue. If so, the base station allocates the required bandwidth. Otherwise, if there is not enough bandwidth to satisfy the queue, the base station implements the queue-specific fairness algorithm described above.

Base Station Uplink

In one preferred embodiment, based upon the ATDD split described above with reference to FIG. 2, the base station has a pre-determined number of PSs in the TDD frame available for uplink transmissions. The base station must maintain an estimate of the data and control messages pending at each QoS for the CPEs that it serves. The base station estimates the data traffic based upon the bandwidth requests received from the CPEs and based upon an observation of actual data traffic. The base station estimates the uplink control message traffic based upon the protocols currently engaged (i.e., connection establishment, "poll-me" bit usage, etc.) and based upon the base station's polling policy (i.e., individual, multicast, and broadcast). The uplink bandwidth allocation algorithm proceeds as follows.

For connections with uplink continuous grant data pending, the base station preferably determines the number of PIs required to transmit the data. This number is then converted to a number of PSs as determined by the modulation used for the CPE associated with each connection. Continuous grant connections having a current bandwidth that is less than the maximum bandwidth are always allocated uplink bandwidth that is the smaller of: 1) their maximum bandwidth or 2) their current bandwidth plus the bandwidth necessary to send a CG bandwidth change message.

For each remaining QoS, or until available bandwidth is entirely allocated, the base station determines if there is bandwidth sufficient to satisfy the entire need of the QoS queue and it then allocates the required bandwidth. Otherwise, if there is not bandwidth sufficient to satisfy the queue, the base station implements the queue-specific fairness algorithm described above.

CPE Uplink

As described above, for each TDD frame, the CPEs are allocated a portion of the uplink sub-frame in which to transmit their respective data. Because the bandwidth require-

ments of the CPE may have changed since the base station received the bandwidth request information that it used to allocate the uplink bandwidth, the CPEs themselves are responsible for allocating their allotted bandwidth based upon their current bandwidth requirements. That is, the CPEs are not constrained to distribute allocated bandwidth to their data connections in the same manner that the CPE used in requesting the bandwidth from the base station. The CPE's uplink bandwidth allocation algorithm preferably proceeds as follows.

For connections having uplink continuous grant data pending, the CPE determines the number of PIs that are required to transmit the data. This number is then converted to a PS number based upon the modulation scheme used by the CPE. For each remaining QoS, or until available bandwidth is entirely allocated, the CPE determines if there is bandwidth sufficient to satisfy the entire need of the QoS queue. If so, the CPE allocates the required bandwidth. Otherwise, if there is not bandwidth sufficient to satisfy the queue, the CPE implements the queue-specific fairness algorithm described above.

SUMMARY

In summary, the bandwidth allocation method and apparatus of the present invention includes a powerful, highly efficient means for allocating bandwidth in a broadband wireless communication system. The present bandwidth allocation method and apparatus uses a combination of individual and group polling techniques, contention-based polling, piggybacking, and CPE-initiated techniques to efficiently allocate bandwidth in a communication system. Advantageously, only those currently active CPEs (CPEs that currently have bandwidth allocations associated thereto) are permitted to request more bandwidth using either the piggybacking or poll-me bit methods. In addition, the present invention saves bandwidth by implicitly informing the CPE of additional bandwidth allocation. The base station implicitly informs the CPE of additional bandwidth allocation by allocating additional bandwidth to the CPE in the uplink sub-frame map. Similarly, the base stations implicitly poll the CPEs by allocating bandwidth in the uplink to enable the CPEs to respond to the poll with a bandwidth request.

In honoring the bandwidth requests, the base station builds and maintains a logical queue of the data to be transmitted. The queues are developed by the base stations based upon the QoS. In addition, the base station allocates bandwidth based on a combination of QoS and a QoS unique fairness algorithm. The CPE itself, rather than the base station, distributes the allocated bandwidth to its services in any manner the CPE determines to be appropriate. Thus, the CPE can use its allocated bandwidth in a manner that differs from the originally intended (and requested) purpose.

A number of embodiments of the present invention have been described. Nevertheless, it will be understood that various modifications may be made without departing from the spirit and scope of the invention. For example, the present inventive method and apparatus can be used in any type of communication, its use is not limited to a wireless communication system. One such example is use of the invention in a satellite communication system. In such a communication system, satellites replace the base stations described above. In addition, the CPEs are not longer at fixed distances from the satellites. Therefore, it will be more difficult to schedule DAMA services for the CPEs. Alternatively, the present invention can be used in a wired communication system. The only difference between the wired system and the wireless system described above is that the channel characteristics

23

vary between the two. However, the bandwidth allocations do not change as between the two types of systems. Accordingly, it is to be understood that the invention is not to be limited by the specific illustrated embodiment, but only by the scope of the appended claims.

The invention claimed is:

1. A method of allocating uplink (UL) bandwidth in a wireless subscriber unit in communication with an associated base station, the method comprising:

placing, at the subscriber unit, data received on one or more connections into queues, based on the quality of service (QoS) of the data;

transmitting from the subscriber unit a one bit message to the base station informing the base station that the subscriber unit has data awaiting transmission;

receiving at the subscriber unit a bandwidth request opportunity comprising an amount of UL bandwidth; and transmitting a bandwidth request within the amount of UL bandwidth, the bandwidth request specifying a requested amount of UL bandwidth pertaining to at least a queue at the subscriber unit.

2. A method as claimed in claim 1, further comprising: receiving an uplink (UL) map with current UL bandwidth allocations for a plurality of subscriber units, including the subscriber unit;

identifying in the UL map an UL bandwidth grant allocated to the subscriber radio unit; and allocating the UL bandwidth grant to one or more of a plurality of connections served by the subscriber unit based on a communication parameter associated with each connection.

3. A method as claimed in claim 1, wherein an UL bandwidth grant is allocated based on a communication parameter which includes a connection priority.

24

4. A method as claimed in claim 1 wherein the subscriber unit is informed that the bandwidth request has been granted, by receiving an UL bandwidth grant in a subsequent UL frame map.

5. A method as claimed in claim 1, wherein the requested amount of UL bandwidth identifies bandwidth required in addition to a UL bandwidth grant previously allocated to the subscriber unit.

6. A method of allocating uplink bandwidth in a subscriber unit, comprising:

transmitting from the subscriber unit a message requesting to be polled;

receiving at the subscriber unit an opportunity to request bandwidth comprising an amount of UL bandwidth;

transmitting a bandwidth request within the amount of UL bandwidth, the bandwidth request specifying a requested amount of UL bandwidth pertaining to at least one of a plurality of connections established at the subscriber unit; and

receiving an UL bandwidth grant for the subscriber unit in response to the bandwidth request, the UL bandwidth grant being identified in a UL frame map.

7. A method as claimed in claim 6, further comprising allocating the UL bandwidth grant to one or more connections of the plurality of connections established at the subscriber unit, which could be different from the at least one connection for which the bandwidth request has been sent.

8. A method as claimed in claim 6, wherein the subscriber unit allocates the UL bandwidth grant to one or more of the connections it serves based on a communication parameter associated to each connection.

9. A method as claimed in claim 8, wherein the communication parameter includes the QoS of the connections established at the subscriber unit.

* * * * *