

1
2
3
4
5
6
7 UNITED STATES DISTRICT COURT
8 SOUTHERN DISTRICT OF CALIFORNIA
9

10 DAIMLER AG, a German corporation,
11 Plaintiff,
12 v.
13 A-Z WHEELS LLC d/b/a USARim.COM,
14 et al.,
15 Defendants.

Case No.: 16-CV-875-JLS (MDD)

**ORDER GRANTING PLAINTIFF'S
MOTION FOR SUMMARY
JUDGMENT**
(ECF No. 58)

16 Presently before the Court is Plaintiff Daimler AG's Motion for Partial Summary
17 Judgment, ("MSJ," ECF No. 58-1). Also before the Court is Defendants' Opposition to
18 the Motion, ("Opp'n," ECF No. 70), and Plaintiff's Reply in Support of the Motion,
19 ("Reply," ECF No. 73). The Court heard oral argument on August 8, 2018. After
20 considering the Parties' arguments and the law, the Court **GRANTS** the Motion for Partial
21 Summary Judgment.

22 **BACKGROUND**

23 Plaintiff Daimler AG produces "premier luxury automotive vehicles and parts"
24 including wheels. (First Amended Complaint, "FAC," ECF No. 33, ¶ 3.) Plaintiff
25 produces and sells worldwide "its vehicles and related parts under the distinctive
26 Mercedes-Benz brand." (*Id.* ¶ 17.) Plaintiff owns federal trademark and service mark
27 registrations for various marks; as relevant here, the mark MERCEDES-BENZ and the
28

1 “Three-Point Star” mark. (*Id.* ¶ 22.)¹ Plaintiff states it uses the mark MERCEDES-BENZ
2 in connection with advertising and selling vehicles and goods. (*Id.* ¶ 19.) Plaintiff also
3 uses the Three-Point Star mark “in connection with advertising and selling Mercedes-Benz
4 vehicles and/or related goods and services.” (*Id.*) Plaintiff also owns various design
5 patents, as relevant here, U.S. Design Patent No. D542,211 (“the ’D211 patent”). (*Id.* ¶
6 35.)

7 Plaintiff has filed a Complaint against various Defendants: (1) A-Z Wheels LLC
8 d/b/a USArim, USArim.com, and Eurotech Wheels; (2) Galaxy Wheels & Tires, LLC; (3)
9 Infobahn International, Inc. d/b/a Infobahn, Eurotech, Eurotech Luxury Wheels, Eurotech
10 Wheels, and USArim; (4) Rasool Moalemi a/k/a/ Russ Moalemi d/b/a ABC Wheels, XYZ
11 Wheels, OEMWheelPlus, USArim, Galazy Wheels, A-Z Wheels, and Eurotech; (5) Ryan
12 Moalemi; and (6) Joshua Moalemi. Plaintiff claims Defendants operate a website where
13 they advertise and sell automotive wheels. (*Id.* ¶ 41.) Plaintiff claims Defendants are using
14 Plaintiff’s trademarks “in connection with the manufacture, offer for sale, sale and
15 distribution of wheels which are not manufactured, authorized or sold by” Plaintiff. (*Id.* ¶
16 1.) Plaintiff also claims Defendants are reproducing, manufacturing, selling, and
17 distributing wheels “which blatantly copy issued design patents in various distinctive and
18 artistic wheel designs owned by” Plaintiff. (*Id.*) Plaintiff moves for summary judgment
19 on its trademark infringement and counterfeiting claim, (MSJ 9), and its design patent
20 infringement claim, (*id.* at 17).

21 LEGAL STANDARD

22 Under Federal Rule of Civil Procedure 56(a), a party may move for summary
23 judgment as to a claim or defense or part of a claim or defense. Summary judgment is
24 appropriate where the Court is satisfied that there is “no genuine dispute as to any material
25



(FAC ¶ 19)

1 fact and the movant is entitled to judgment as a matter of law.” Fed. R. Civ. P. 56(a);
2 *Celotex Corp. v. Catrett*, 477 U.S. 317, 322 (1986). Material facts are those that may affect
3 the outcome of the case. *Anderson v. Liberty Lobby, Inc.*, 477 U.S. 242, 248 (1986). A
4 genuine dispute of material fact exists only if “the evidence is such that a reasonable jury
5 could return a verdict for the nonmoving party.” *Id.* When the Court considers the
6 evidence presented by the parties, “[t]he evidence of the non-movant is to be believed, and
7 all justifiable inferences are to be drawn in his favor.” *Id.* at 255.

8 The initial burden of establishing the absence of a genuine issue of material fact falls
9 on the moving party. *Celotex*, 477 U.S. at 323. The moving party may meet this burden
10 by identifying the “portions of ‘the pleadings, depositions, answers to interrogatories, and
11 admissions on file, together with the affidavits, if any,’” that show an absence of dispute
12 regarding a material fact. *Id.* When a plaintiff seeks summary judgment as to an element
13 for which it bears the burden of proof, “it must come forward with evidence which would
14 entitle it to a directed verdict if the evidence went uncontroverted at trial.” *C.A.R. Transp.*
15 *Brokerage Co. v. Darden Rests., Inc.*, 213 F.3d 474, 480 (9th Cir. 2000) (quoting *Houghton*
16 *v. South*, 965 F.2d 1532, 1536 (9th Cir. 1992)).

17 Once the moving party satisfies this initial burden, the nonmoving party must
18 identify specific facts showing that there is a genuine dispute for trial. *Celotex*, 477 U.S.
19 at 324. This requires “more than simply show[ing] that there is some metaphysical doubt
20 as to the material facts.” *Matsushita Elec. Indus. Co. v. Zenith Radio Corp.*, 475 U.S. 574,
21 586 (1986). Rather, to survive summary judgment, the nonmoving party must “by her own
22 affidavits, or by the ‘depositions, answers to interrogatories, and admissions on file,’
23 designate ‘specific facts’” that would allow a reasonable fact finder to return a verdict for
24 the non-moving party. *Celotex*, 477 U.S. at 324; *Anderson*, 477 U.S. at 248. The non-
25 moving party cannot oppose a properly supported summary judgment motion by “rest[ing]
26 on mere allegations or denials of his pleadings.” *Anderson*, 477 U.S. at 256.

27 ANALYSIS

28 Plaintiff moves for summary judgment against all of the above entity Defendants

1 (the “Entity Defendants”) and Rasool Moalemi. (Reply 2.) Plaintiff moves for summary
2 judgment on its trademark infringement and counterfeiting claims and on its design patent
3 infringement claim. The Court will first analyze the alleged trademark infringement and
4 second the alleged design patent infringement. The Court will then analyze the alleged
5 personal liability of Mr. Moalemi and liability of the Entity Defendants.

6 **I. Trademark Infringement and Counterfeiting**

7 Plaintiff states it owns valid federal registrations in class 12 for the mark
8 MERCEDES-BENZ, (U.S. Reg. No. 657,386), and for its Three-Point Star design (U.S.
9 Reg. Nos. 3,614,891 and 4,423,458). (FAC ¶ 22; MSJ 10.) Plaintiff claims Defendants
10 are infringing both marks.

11 **A. Trademark Infringement**

12 To state a valid cause of action for trademark infringement under the Lanham Act,
13 a plaintiff “must prove: (1) that it has a protectable ownership interest in the mark; and (2)
14 that the defendant’s use of the mark is likely to cause consumer confusion.” *Rearden LLC*
15 *v. Rearden Commerce, Inc.*, 683 F.3d 1190, 1202 (9th Cir. 2012) (quoting *Network*
16 *Automation, Inc. v. Advanced Sys. Concepts, Inc.*, 638 F.3d 1137, 1144 (9th Cir. 2011)).

17 As to the first factor, “[t]o acquire ownership of a trademark it is not enough to have
18 invented the mark first or even to have registered it first; the party claiming ownership must
19 have been the first to actually use the mark in the sale of goods or services.” *Sengoku*
20 *Works Ltd. v. RMC Int’l, Ltd.*, 96 F.3d 1217, 1219 (9th Cir. 1996) (citation omitted).
21 “Therefore, a party pursuing a trademark claim must meet a threshold ‘use in commerce’
22 requirement.” *Rearden LLC*, 683 F.3d at 1203. “[R]egistration of the mark on the Principal
23 Register in the Patent and Trademark Office constitutes prima facie evidence of the validity
24 of the registered mark and of . . . exclusive right to use the mark on the goods and services
25 specified in the registration.” *Brookfield Commc’ns, Inc. v. W. Coast Entm’t Corp.*, 174
26 F.3d 1036, 1047 (9th Cir. 1999). The opposing party may rebut the presumption of
27 ownership by showing it used the mark in commerce first. *Id.* Here, Plaintiff has shown
28 it owns valid registrations for the marks at issue. (See FAC ¶ 22.) Defendants make no

1 argument rebutting this presumption, thus, Plaintiff has established a protectable ownership
2 interest in the marks. The Court’s inquiry therefore focuses on likelihood of confusion.

3 In analyzing whether there is a likelihood of confusion between the two marks at
4 issue, courts consider eight factors, known as the *Sleekcraft* factors. *Rearden LLC*, 683
5 F.3d at 1209. These eight factors are: (1) strength of the mark; (2) proximity of the goods;
6 (3) similarity of the marks; (4) evidence of actual confusion; (5) marketing channels used;
7 (6) type of goods and the degree of care likely to be exercised by the purchaser; (7)
8 defendant’s intent in selecting the mark; and (8) likelihood of expansion of the product
9 lines. *Id.* (citing *AMF Inc. v. Sleekcraft Boats*, 599 F.2d 341, 348–49 (9th Cir. 1979),
10 *abrogated in part by Mattel, Inc. v. Walking Mountain Prods.*, 353 F.3d 792 (9th Cir.
11 2003)). However, these eight factors are not exhaustive and “other variables besides the
12 enumerated factors should also be taken into account based on the particular
13 circumstances.” *Id.* Additionally, “[w]hen the goods produced by the alleged infringer
14 compete for sales with those of the trademark owner, infringement usually will be found if
15 the marks are sufficiently similar that confusion can be expected.” *Sleekcraft*, 599 F.2d at
16 348.

17 Furthermore, the counterfeiting of another’s trademark establishes a presumption of
18 a likelihood of confusion.² *Brookfield Commc’ns*, 174 F.3d at 1056 (“In light of the virtual
19 identity of marks, if they were used with identical products or services likelihood of
20 confusion would follow as a matter of course.”); *see Louis Vuitton Malletier, S.A. v. Akanoc*
21 *Sols., Inc.*, 658 F.3d 936, 945 (9th Cir. 2011) (“[T]he presumption [of likelihood of
22 confusion] arises when intent to cause confusion is coupled with the use of a counterfeit
23 mark or a mark virtually identical to a previously registered mark.”).

24 1. *MERCEDES-BENZ* Mark

25 Plaintiff argues the Court should enter summary judgment as to infringement of its
26

27
28 ² A counterfeit mark is defined as “a spurious mark which is identical with, or substantially
indistinguishable from, a registered mark.” 15 U.S.C. §§ 1116(d)(1)(B), 1127.

1 MERCEDES-BENZ mark. (MSJ 11.) It is obvious, and Defendants do not even appear
2 to contest, that Defendants sell goods using the MERCEDES-BENZ mark; Defendants
3 advertise products for sale as “Mercedes Benz” wheels. (*See, e.g.*, ECF No. 58-25, at 11
4 (screenshot of USArim.com selling “Mercedes Benz Wheels”).) Defendants use the mark
5 identically. Defendants also sell products that compete with Plaintiff’s products.

6 a. Likelihood of Confusion

7 The Court first acknowledges that the issue of likelihood of confusion is inherently
8 factual. *See Fortune Dynamic, Inc. v. Victoria’s Secret Stores Brand Mgmt., Inc.*, 618 F.3d
9 1025, 1039 (9th Cir. 2010) (noting that “‘likelihood of confusion is a factual
10 determination,’ and ‘district courts should grant summary judgment motions regarding the
11 likelihood of confusion sparingly’” (quoting *Thane Int’l, Inc. v. Trek Bicycle Corp.*, 305
12 F.3d 894, 901–02 (9th Cir. 2002))). But, the Court agrees with other district courts in this
13 state that have approved “summary judgment [on the issue] so long as (1) the ultimate
14 determination of likelihood of confusion is based on a record of undisputed material facts
15 and (2) these undisputed material facts, when applied to the multi-factor likelihood of
16 confusion analysis, demonstrate that there is only one conclusion a trier of fact could
17 reasonably draw.” *Health Net v. U.S.A. Healthnet, Inc.*, No. CV 92-3925 KN, 1993 WL
18 209558, at *1 (C.D. Cal. May 12, 1993) (citing cases).

19 It is not necessary for the Court to analyze the likelihood of confusion test here
20 considering Defendants’ use the identical MERCEDES-BENZ mark. *See Phillip Morris
21 USA Inc. v. Shalabi*, 352 F. Supp. 2d 1067, 1073 (C.D. Cal. 2004) (“[I]n cases involving
22 counterfeit marks, it is unnecessary to perform the step-by-step examination . . . because
23 counterfeit marks are inherently confusing.”). However, the Court will address the one
24 *Sleekcraft* factor that Defendants have argued weighs in their favor.

25 The sixth *Sleekcraft* factor analyzes the type of goods and the degree of care likely
26 to be exercised by the purchaser. This is the factor that Defendants deem the “most
27 important.” (Opp’n 6.) Defendants argue consumers research wheels in-depth before
28 making a purchase to ensure the wheel will fit their automobile. (*Id.* at 7.) Defendants

1 argue because their wheels are “significantly less expensive” than Plaintiff’s wheels, a
2 reasonably prudent consumer “will be more discerning and less likely to confuse
3 Defendants’ and Plaintiff’s products.” (*Id.*) Defendants argue a consumer would “discover
4 that Defendants sell aftermarket near-replicas as well as custom wheels.” (*Id.*) Indeed, the
5 Ninth Circuit has held that when the accused products are expensive (i.e., selling for several
6 hundred dollars), the relevant consumer “is a reasonably prudent consumer accustomed to
7 shopping online.” *Multi Time Machine, Inc. v. Amazon.com, Inc.*, 804 F.3d 930, 936 (9th
8 Cir. 2015) (citing *Toyota Motor Sales, U.S.A., Inc. v. Tabari*, 610 F.3d 1171, 1176 (9th Cir.
9 2010)).

10 The Court agrees with Defendants’ preliminary argument in that it is plausible that
11 a person buying a wheel rim on the Internet, sight unseen, would do his or her research and
12 look closely at the products. However, even if the hypothetical consumer were to spend
13 time looking at Defendants’ products on USArim.com, there is nothing on the website that
14 would ease Plaintiff’s concerns of confusion. For some wheels, USArim.com refers to the
15 wheel as a “replica” Mercedes Benz wheel, but this is not always the case. Even if a
16 consumer were to read the entire product description of the wheel on, for example, eBay,
17 that consumer would most likely not be alerted to the fact that the wheel is only a replica.³
18 Nor would the consumer be alerted to the fact that Mercedes does not condone the sale of
19 the wheel. Therefore, this factor does not weigh in Defendants’ favor and does not negate
20 the likelihood of confusion that is presumed due to Defendants’ use of Plaintiff’s exact
21 mark on products that compete with Plaintiff’s products. *See Brookfield Commc’ns*, 174
22

23
24 ³ Plaintiff has included a screenshot of the “About Us” section of USArim.com. This states: “Some of our
25 wholesale partners include . . . Mercedes Benz.” (ECF No. 58-19, at 36.) It also states: “We manufacture
26 our wheels in several OEM approved factories through Asia.” (*Id.* at 37.) OEM stands for “original
27 equipment manufacturer.” Mr. Moalemi admitted he does not “deal with the Mercedes-Benz-approved
28 factory.” (“Moalemi Depo.,” ECF No. 58-19, at 12.) He testified that the statements from the website
mean his company “go[es] through” a company that “do[es] wheels for” Mercedes. (*Id.*) But, there is no
evidence that consumers looking at the website would read the statements in this way. The Court finds
the statements on the website are likely to confuse consumers as to whether Defendants are linked to or
even sponsored by Plaintiff.

1 F.3d at 1056. The Court finds Plaintiff has shown there is no disputed fact that a consumer
2 would likely be confused by Defendants’ use of Plaintiff’s mark. The Court now analyzes
3 Defendants’ arguments opposing the allegation of infringement.⁴

4 b. Nominative Fair Use Doctrine

5 Defendants argue nominative fair use shields them from liability. (Opp’n 5.)
6 Defendants argue they “primarily use Plaintiff’s ‘Mercedes-Benz’ trademark in its
7 descriptive sense, in order to convey that Defendants’ wheels are near-replicas of
8 Mercedes-Benz wheels and that they will generally fit on Plaintiff’s vehicles.” (Opp’n 5.)
9 Defendants argue therefore, “a reasonable juror could find that Defendants’ use of
10 ‘Mercedes-Benz’ to identify wheels as replicas is a nominative fair use.” (*Id.*) The Court
11 first analyzes whether the nominative fair use doctrine applies to this case at all.

12 “The nominative fair use analysis is appropriate where a defendant has used the
13 plaintiff’s mark to describe the plaintiff’s product, even if the defendant’s ultimate goal is
14 to describe his own product.” *Cairns v. Franklin Mint Co.*, 292 F.3d 1139, 1151 (9th Cir.
15 2002). Indeed, in *Volkswagenwerk Aktiengesellschaft v. Church*, 411 F.2d 350 (9th Cir.
16 1969), an automobile repair business specializing in the repair of Volkswagen and Porsche
17 vehicles placed a large sign on the front of the premises that read “Modern Volkswagen
18 Porsche Service.” *Id.* at 351. The Ninth Circuit found the alleged infringer was using the
19 “Volkswagen” trademark to describe the automobile, but its ultimate goal was to describe
20 its own product—a repair shop specializing in the repair of Volkswagens. *Id.* at 352.
21 Application of the nominative fair use analysis was therefore appropriate. *See Cairns*, 292
22 F.3d at 1152 (analyzing *Volkswagenwerk*).

23
24 ⁴ Defendants first argue they have used this mark only “to advertise Defendants’ own aftermarket/replica
25 wheels online” so likelihood of confusion should be considered only at the time of sale. (Opp’n 4.)
26 Defendants state the mark “is not seen by the public when the wheels are in use.” (*Id.*) The Court is
27 unable to determine how this argument combats the allegation of infringement. Plaintiff has alleged
28 Defendants are using Plaintiff’s mark to sell products online, and consumers would clearly see the wheels
and the mark online when buying purchasing the products. It is irrelevant that the words “Mercedes Benz”
are not imprinted on the wheel itself. The Court rejects Defendants’ argument as unclear and illogical.

1 Here, if Defendants’ website was worded as Defendants describe to the Court, i.e.,
2 “We Sell Replica Mercedes Benz Wheels” or “Our Wheels Look Great on Mercedes-Benz
3 Cars!”, then the Court would agree with Defendants that the nominative fair use test applies
4 and proceed to analyze the factors of the test. Certain postings on Defendants’ website
5 support Defendants’ contention, (*see* ECF Nos. 33-62, 33-63 (USArim.com selling
6 “replica” Mercedes wheel rims), but many do not. USArim.com advertises for sale “17
7 inch chrome Mercedes Benz wheels rims,” (ECF No. 33-63, at 2), and other rims without
8 using the word “replica” in the description. (ECF No. 33-65, at 2; ECF No. 33-67, at 2;
9 ECF No. 33-68, at 2; ECF No. 33-69, at 2.) There is no indication that Defendants are
10 using Plaintiff’s “Mercedes-Benz” mark to describe Plaintiff’s product. *Contra Smith v.*
11 *Chanel, Inc.*, 402 F.2d 562 (9th Cir. 1968) (finding the nominative fair use defense applied
12 where the defendant advertised his “2d Chance” perfume as indistinguishable from the
13 trademarked “Chanel #5 perfume”). Defendants are not using the mark to compare their
14 wheels to Plaintiff’s wheels, and do not even reference Plaintiff’s wheels in the online
15 postings. Defendants are using the mark solely to describe their own products. Therefore,
16 the nominative fair use analysis is not appropriate in this situation.⁵ Nominative fair use
17 does not protect Defendants’ use of Plaintiff’s mark.⁶

18 c. Conclusion

19 The Court acknowledges that in most cases, it is not appropriate to find summary
20 judgment on a likelihood of confusion analysis. However, in this case, when Defendants
21

22
23 ⁵ The court in *Cairns* held that in such a situation (i.e., if the defendant uses the mark to describe the
24 plaintiff’s product), courts should analyze infringement using the classic fair use test. 292 F.3d at 1152.
25 Under this defense, “[a] defendant must show that its use is (1) other than as a trademark, (2) descriptive
26 of the defendant’s goods, and (3) in good faith.” *Marketquest Grp., Inc. v. BIC Corp.*, 862 F.3d 927, 935
27 (9th Cir. 2017) (citing 15 U.S.C. § 1115(b)(4)). Defendants do not claim the fair use defense applies and
28 have thus not attempted to prove these factors.

⁶ In further arguing against trademark infringement, Defendants refer to two sets of wheels that Plaintiff
“claims are sold by Defendants.” (Opp’n 9.) These are products: MBZ-525-22-blk and MBZ-521-19-
GMT. Defendants argue these wheels are sold on Amazon by Wheel Outlet Direct and there is no evidence
Defendants operate Wheel Outlet Direct. (*Id.*) This does not negate the fact that Defendants sold other
infringing products.

1 are using Plaintiff’s exact trademark with the intent of selling replica products, without
2 always using the word “replica” on the website, the Court finds there is no dispute that
3 Plaintiff has proven a likelihood of confusion. The Court **GRANTS** Plaintiff’s Motion for
4 Summary Judgment for trademark infringement of the MERCEDES-BENZ mark.

5 *2. Three Point Star Mark*

6 Plaintiff also moves for summary judgment on its claim of trademark infringement
7 of its Three-Point Star mark. (MSJ 14.) In 2015, Plaintiff’s investigator purchased wheels
8 from USArim.com. The wheels contain the Three-Point Star mark on the center cap. (*See*
9 ECF Nos. 33-79, 33-80.) The Three-Point Star mark on the wheels sold on USArim.com
10 is not altered or changed from Plaintiff’s mark in any way.⁷

11 Plaintiff makes the same arguments as to why the *Sleekcraft* factors weigh in its
12 favor for this mark as it did for the MERCEDES-BENZ mark. Again, the Court finds it
13 unnecessary to analyze the likelihood of confusion test because the marks are identical. In
14 response to Plaintiff’s allegation of infringement, Defendants argue the first sale doctrine
15 applies. (Opp’n 8.)

16 a. First Sale Doctrine

17 Defendants appear to acknowledge the end caps on the wheels contain the Three-
18



19
20
21
22
23
24 ⁷ Compare (ECF No. 33-80 (the product purchased from USArim.com)), with



25
26
27
28 (Plaintiff’s registered trademark, U.S. Reg. No. 4,423,458).

1 Point Star mark.⁸ But, Defendants argue they are protected by the first sale doctrine. They
2 state they have purchased “authentic end caps from used Mercedes-Benz dealers” and a
3 jury could conclude that Defendants “only stocked and resold” genuine caps without
4 materially altering them. (Opp’n 8.)

5 The “first sale” doctrine states that once a product enters the market, its trademark
6 is not infringed by subsequent sales. *See Sebastian Int’l. Inc. v. Longs Drug Stores Corp.*,
7 53 F.3d 1073, 1074 (9th Cir. 1995) (“Resale by the first purchaser of the original article
8 under the producer’s trademark is neither trademark infringement nor unfair
9 competition.”). The doctrine protects a purchaser who “does no more than stock, display,
10 and resell a producer’s product under the producer’s trademark.” *Id.* at 1076. The doctrine
11 applies even when there is a likelihood of consumer confusion. *Upper Deck Authenticated,*
12 *Ltd. v. CPG Direct*, 971 F. Supp. 1337, 1341 (S.D. Cal. 1997) (citing *Sebastian*, 53 F.3d at
13 1047).

14 Plaintiff argues this doctrine does not apply to Defendants’ sale of the caps because
15 Defendants have not proven the caps are genuine. (Reply 3); *see Sebastian*, 53 F.3d at
16 1076 (finding the defendants were protected by the doctrine because they “stock and resell
17 genuine” products “lawfully acquired on the open market”). Indeed, the only evidence
18 produced by Defendants that the caps are genuine is a declaration by Mr. Moalemi stating
19 such. (“Moalemi Decl.,” ECF No. 70-1, ¶ 5.) There is no evidence to support this
20 declaration, and the declaration is disproven by Plaintiff’s evidence. Plaintiff produced a
21 picture of a wheel purchased by its investigator from USARim.com. (ECF No. 33-80, at
22 2.) This wheel contains an end cap with the three-point star. Plaintiff also produced at oral
23 argument an end cap that came attached to a wheel purchased by Plaintiff’s investigator.
24 Plaintiff states its investigator purchased wheels, including the 19-GMT wheel, from
25 Defendants that included the end cap bearing the three-point star design. (MSJ 15.)
26 Plaintiff also included a declaration by Sven-Eric Widmayer, Legal Counsel for Legal
27

28 ⁸ The Court, like the Parties, will use “center caps” and “end caps” interchangeably.

1 Global Litigation – Brand Protection at Daimler AG. (ECF No. 89-1.) Mr. Widmayer
2 declares “[t]he purchased 20-AMG wheels . . . and the purchased 19-GMT wheels . . .
3 [from USARIM] are not genuine products manufactured or authorized by Daimler.” (*Id.*
4 ¶ 9.a.) The wheels use the three-point star mark. (*Id.* ¶¶ 9.b., 9.c.)

5 The Court has examined the two products produced at oral argument and determines
6 the end cap from Defendants’ wheels is clearly different from Plaintiff’s end cap. The back
7 of Plaintiff’s end cap contains a part number. The back of Defendants’ end cap contains a
8 sticker with what appears to be Chinese characters printed on it.⁹ These clear differences,
9 along with the evidence and declaration provided by Plaintiff, negate Mr. Moalemi’s
10 unsupported declaration that Defendants’ end caps are genuine. Therefore, Defendants are
11 not protected by the first sale doctrine. As analyzed above, Plaintiff has proven the marks
12 are identical, thus, the Court **GRANTS** Plaintiff’s Motion for Summary Judgment for
13 trademark infringement of the three-point star mark.

14 ***B. Trademark Counterfeiting***

15 To state a valid cause of action for trademark counterfeiting under the Lanham Act,
16 a plaintiff must show that its mark is valid and has been infringed. 15 U.S.C. § 1114(1).
17 Registration of a mark on the principal register is “prima facie evidence . . . of the
18 registrant’s ownership of the mark, and of the registrant’s exclusive right to use the
19 registered mark in commerce.” 15 U.S.C. § 1115(a). The Lanham Act prohibits use of
20 “counterfeit” marks in connection with the “sale, offering for sale, or distribution of
21 goods.” 15 U.S.C. § 1116(d)(1)(A). A counterfeit mark is defined as “a spurious mark
22 which is identical with, or substantially indistinguishable from, a registered mark.” 15
23 U.S.C. §§ 1116(d)(1)(B), 1127.

24 As discussed, Plaintiff has valid trademark registrations for several marks. (FAC ¶
25 22.) Furthermore, Plaintiff has proven there is no issue of material fact that Defendants
26

27 ⁹ The Court requested the Parties bring in wheels as demonstrative exhibits to the oral argument hearing.
28 (*See* ECF No. 87.) At the hearing, the Court asked if the demonstratives could become part of the record
in this matter. Both Parties agreed.

1 have infringed its Mercedes-Benz mark and three-point star mark and sell and advertise
2 rims using Plaintiff’s identical mark. *See supra* Section I.A. Thus, the Court **GRANTS**
3 Plaintiff’s Motion for Summary Judgment on its claim of trademark counterfeiting for the
4 Mercedes-Benz mark and the three-point star mark.

5 **II. Design Patent Infringement**

6 Plaintiff alleges Defendants are infringing U.S. Design Patent No. D542,211 (“the
7 ’D211 patent”). (MSJ 18.)¹⁰ Plaintiff has construed the ’D211 as “the ornamental design
8 for a front face of a vehicle wheel, as shown and described in FIGs. 1–4 of the ‘D211
9 Patent.” (*Id.*) Figures 1–4 are reproduced below:

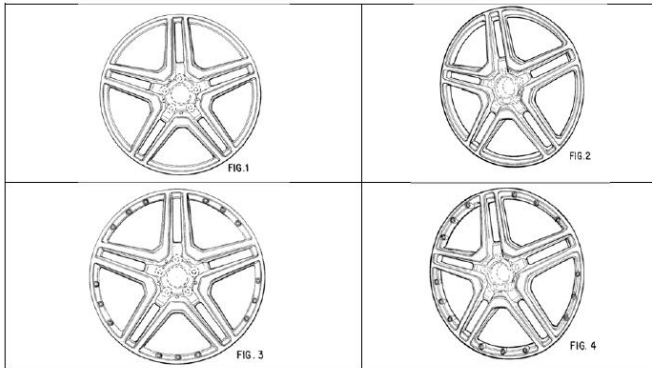

16 **A. Legal Standard**

17 “A design patent protects the nonfunctional aspects of an ornamental design as
18 shown in the patent.” *Elmer v. ICC Fabricating, Inc.*, 67 F.3d 1571, 1577 (Fed. Cir. 1995)
19 (citing *KeyStone Retaining Wall Sys., Inc. v. Westrock Inc.*, 997 F.2d 1444, 1450 (Fed. Cir.
20 1993)). A design patent is infringed by the “unauthorized manufacture, use, or sale of the
21

22
23 ¹⁰ The first procedural issue is whether the Court may evaluate a claim of design patent infringement on
24 summary judgment. *See Grayson v. McGowan*, 543 F.2d 79, 80 (9th Cir. 1976) (“It is long established in
25 this circuit that, when the Rule 56 standards are met and the court, without aid of expert opinion, can
26 understand the prior art and patent claims, summary judgment is proper.”). The Court finds it can analyze
27 the prior art and patent claims without expert opinion and may thus consider Plaintiff’s request for
28 summary judgment. The Court has been provided with both wheel rims at issue and has physically
compared them. Neither side has presented any expert opinion to support their position, and the Court
finds reference to any outside evidence or opinion is unnecessary in this case.

1 article embodying the patented design or any colorable imitation thereof.” *Goodyear Tire*
2 *& Rubber Co. v. Hercules Tire & Rubber Co.*, 162 F.3d 1113, 1116–17 (Fed. Cir. 1998).

3 An analysis of design patent infringement first involves a claim construction. *See*
4 *Seirus Innovative Accessories, Inc. v. Cabela’s Inc.*, 827 F. Supp. 2d 1150, 1155 (S.D. Cal.
5 2011) (“A determination of design patent infringement involves a two step analysis. First,
6 the claim must be properly construed to determine its meaning and scope. Secondly, the
7 properly construed claim must be compared to the accused design to determine whether
8 there has been infringement.” (citing *Elmer*, 67 F.3d at 1577)).

9 ***B. First Step: Claim Construction***

10 Regarding the first step, “[w]ords cannot easily describe ornamental designs.” *Sport*
11 *Dimension, Inc. v. Coleman Co., Inc.*, 820 F.3d 1316, 1320 (Fed. Cir. 2016). “A design
12 patent’s claim is thus often better represented by illustrations than a written claim
13 construction.” *Id.* (citing *Egyptian Goddess, Inc. v. Swisa, Inc.*, 543 F.3d 665, 679 (Fed.
14 Cir. 2008) (en banc)). Further, “a design patent cannot claim a purely functional design—
15 a design patent is invalid if its overall appearance is ‘dictated by’ its function.” *Sport*
16 *Dimension*, 820 F.3d at 1320 (quoting *Egyptian Goddess, Inc.*, 543 F.3d at 668)). But as
17 long as the design is not primarily functional, “the design claim is not invalid, even if
18 certain elements have functional purposes.” *Ethicon Endo–Surgery, Inc. v. Covidien, Inc.*,
19 796 F.3d 1312, 1333 (Fed. Cir. 2015) (citing *Richardson v. Stanley Works, Inc.*, 597 F.3d
20 1288, 1293–94 (Fed. Cir. 2010)). That is because a design patent’s claim protects an article
21 of manufacture, which “necessarily serves a utilitarian purpose.” *L.A. Gear, Inc. v. Thom*
22 *McAn Shoe Co.*, 988 F.2d 1117, 1123 (Fed. Cir. 1993). A design may contain both
23 functional and ornamental elements, even though the scope of a design patent claim “must
24 be limited to the ornamental aspects of the design.” *Ethicon Endo–Surgery*, 796 F.3d at
25 1333.

26 Plaintiff’s proposed construction is “the ornamental design for a front face of a
27 vehicle wheel, as shown and described in FIGs. 1–4 of the ‘D211 Patent.’” Defendants do
28 not address this construction or offer an alternative construction. The Court finds this

1 construction properly “factors out the functional aspects” of the patent design. *Richardson*
2 *v. Stanley Works, Inc.*, 597 F.3d 1288, 1294 (Fed. Cir. 2010); *see also Contessa Food*
3 *Prods., Inc. v. Conagra, Inc.*, 282 F.3d 1370, 1377 (Fed. Cir. 2002) (approving a district
4 court’s construction of the asserted claim as meaning “a tray of a certain design as shown
5 in Figures 1–3”). The Court finds that any further “verbal elaboration” in the claim is not
6 “necessary or helpful” and adopts the proposed construction. *See Egyptian Goddess*, 543
7 F.3d at 679.

8 ***C. Second Step: Infringement***

9 Defendants argue there are “a number of significant differences between the accused
10 and protected designs.” (Opp’n 9.) These differences recognized by Defendants are: First,
11 Plaintiff’s design “has a sharp drop from the outer, upper rim to the lower, inner rim” but
12 Defendants’ design “has a sloping decline from the outer, upper rim of the wheel that
13 suddenly drops to the lower, inner rim of the wheel.” (Opp’n 11.) Second, Defendants’
14 design has spokes that “are completely smooth along their sides, meeting with the outer
15 rim in such a way that the bottom of the spokes appear to be resting on the top of the lower,
16 inner rim of the wheel” but Plaintiff’s design has spokes that “are not completely smooth
17 along their sides, and appear to have edges or layers to their appearance.” (*Id.*) Third, the
18 spokes on Defendants’ design “rest[] upon” the “rim below the bottom of the lower, inner
19 rim” but the spokes of Plaintiff’s design “merge with the rim below the bottom of the lower,
20 inner rim.” (*Id.*)

21 Overall, the Court considers whether the visual similarity between Defendants’
22 product and the patented designs would likely deceive an ordinary observer. Infringement
23 of a design patent occurs if “the designs have the same general visual appearance, such that
24 it is likely that the purchaser would be deceived into confusing the design of the accused
25 article with the patented design.” *Goodyear*, 162 F.3d at 1118. Complete similarity is not
26 required to find infringement, and “minor changes in a design are often readily made
27 without changing its overall appearance.” *Id.* at 1117.

28 The proper test for infringement of a design patent is whether the ordinary observer,

1 “giving such attention as a purchaser usually gives” and viewing any differences between
2 the patented design and the accused product “in the context of the prior art,” finds that the
3 devices bear such resemblance as to deceive the observer, inducing him or her “to purchase
4 one supposing it to be the other.” *Egyptian Goddess*, 543 F.3d at 670 (internal quotations
5 omitted) (quoting *Gorham Mfg. Co. v. White*, 81 U.S. 511, 528 (1871)). When the products
6 are not “plainly dissimilar,” examination of the prior art might reveal differences between
7 the designs at issue that are unnoticeable “in the abstract,” but significant in the context of
8 the prior art. *Id.* This requires a court to first determine if the products are similar and
9 second to compare the designs to prior art. *Great Neck Saw Mfrs., Inc. v. Star Asia U.S.A.,*
10 *LLC*, 727 F. Supp. 2d 1038, 1052 (W.D. Wash. 2010) (citing *Egyptian Goddess*, 53 F.3d
11 at 678). “In both stages, the appropriate method involves a side-by-side study of the
12 designs.” *Id.* (citing *Crocs, Inc. v. Int’l Trade Comm’n*, 598 F.3d 1294, 1304 (Fed. Cir.
13 2010)).



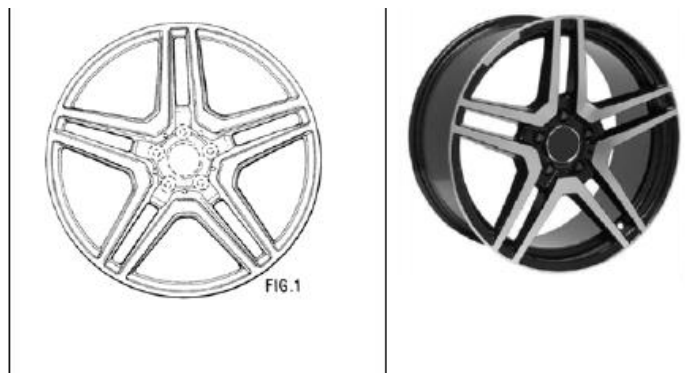





14 Following *Egyptian Goddess*’s two-tiered approach, first, the Court finds the
15 claimed and accused designs are sufficiently similar. In the picture below, the left image
16 is the ‘D211 patent and the right image is a product sold by Defendants on eBay, with part
17 number MBZ-610-19-MB.

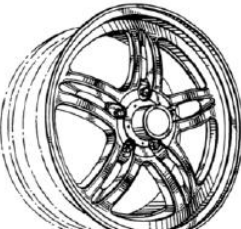

24 The Court finds Plaintiff’s patented design and Defendants’ accused product to be
25 substantially similar. Indeed, Defendants implicitly acknowledge this by pointing the
26 Court to only three minor differences between their product and the patented design.
27 (Opp’n 11.) The Court proceeds to the second tier of the *Egyptian Goddess* test, which
28 entails a comparison to the prior art.

1 Defendants argue the shared portions of their product and the claimed design is “five
 2 sets of two spokes forming a wide angled ‘V’ shape that parallels another set of spokes on
 3 each end” and this is also shared by the prior art. (Opp’n 13.) Defendants argue an ordinary
 4 observer must therefore “disregard the impression caused by the five sets of two spokes”
 5 and focus “only on the impression left by *the other parts* of each design.” (*Id.*)

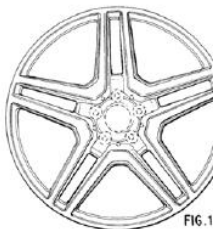
6 Like the patented design and Defendants’ product, the cited prior art contains five
 7 spokes in a starfish pattern that connect to an outer circle. A comparison is set forth below:

Prior Art (SMF ¶ 6.)	‘D211 Patent (SMF ¶ 5.)	MBZ-610-19-MB (SMF ¶ 25.)
 (Wright D564.)	 FIG. 1	
 (Weld D547.)	 FIG. 1	
 (Hussaini D618.)	 FIG. 1	

23
 24 (See MSJ 21.)

25 “[W]hen a claimed design is close to the prior art, the Court may view small
 26 differences between the claimed design and the accused device as being important to the
 27 eye of the hypothetical ordinary observer.” *Great Neck*, 727 F. Supp. 2d at 1053 (citing
 28 *Egyptian Goddess*, 543 F.3d at 676). Of course, the Court must “analyz[e] the design as a

1 whole” and not engage in an “element-by-element comparison” of the devices in question.
2 *Amini Innovation Corp. v. Anthony California, Inc.*, 439 F.3d 1365, 1372 (Fed. Cir. 2006).
3 But, “where a particular design element sharply distinguishes, against the context of the
4 prior art, the claimed design from the accused design, it is not error to focus on that element
5 in the infringement analysis.” *Wing Shing Prods (BVI) Co. Ltd. v. Sunbeam Prods., Inc.*,
6 665 F. Supp. 2d 357, 367 (S.D.N.Y. 2009) (citing *Egyptian Goddess*, 543 F.3d at 680–83).
7 The prior art, as a “frame of reference,” can “highlight the distinctions between the claimed
8 design and the accused design as viewed by the ordinary observer.” *Egyptian Goddess*,
9 543 F.3d at 677.

10 The Court has visually compared the two products, the pictures and figures of the
11 products, and the prior art. The Court finds that the accused device and the claimed design
12 are substantially similar. An ordinary observer would be deceived and could be induced
13 to purchase Defendants’ product over Plaintiff’s. There are no sharp distinguishing
14 features between the two designs against the context of the prior art. Plaintiff has therefore
15 met its burden in proving design patent infringement. The Court **GRANTS** Plaintiff’s
16 Motion for Summary Judgment for design patent infringement of the ’D211 patent.

17 **III. Liability of Defendants**

18 Defendants argue “[n]one of the named Defendants have sold any of the accused
19 infringing products for many years” and Rasool Moalemi “has never sold any products on
20 an individual basis.” (Opp’n 2 n.1.)

21 **A. Liability of Rasool Moalemi**

22 Mr. Moalemi admits that he owns the company ABC Wheels (which is not a
23 defendant in this case) and the company “has been a business under the name ‘UsaRim’
24 and the website ‘usarim.com.’” (Moalemi Decl. ¶ 3.) He states he has never sold any
25 products on an individual basis. (*Id.* ¶ 2.) Plaintiff argues Mr. Moalemi’s conduct abuses
26 the separation between himself and the company and enables him “to be held liable for the
27 trademark infringement and counterfeiting and design patent infringement of the Entity
28 Defendants and ABC Wheels.” (Reply 3.)

1 1. *Piercing the Corporate Veil*

2 In broad summary, Plaintiff argues Mr. Moalemi is the alter ego of his company.
3 The alter ego theory is an equitable doctrine based on California Civil Code 3528. *See*
4 *Webber v. Inland Empire Invs.*, 74 Cal. App. 4th 884, 900 (Ct. App. 1999). Under the alter
5 ego doctrine, “where a corporation is used by an individual or individuals, or by another
6 corporation, to perpetrate fraud, circumvent a statute, or accomplish some other wrongful
7 or inequitable purpose, a court may disregard the corporate entity and treat the
8 corporation’s acts as if they were done by the persons actually controlling the corporation.”
9 *Id.* Thus, a party asserting the doctrine must show two requirements: “(1) a unity of interest
10 and ownership such that the separate personalities of the corporation and the individual no
11 longer exist; and (2) that an inequitable result will follow if the acts are treated as those of
12 the corporation alone.” *Id.* at 899. The California Supreme Court has stated that “the
13 corporate form will be disregarded only in narrowly circumscribed circumstances and only
14 when the ends of justice so require.” *Mesler v. Bragg Mgmt. Co.*, 702 P.2d 601, 607 (Cal.
15 1985).

16 Plaintiff argues “[t]he facts establish that Rasool Moalemi has/had such a unity of
17 interest and ownership in the Entity Defendants and ABC Wheels that Rasool Moalemi
18 and the Entity Defendants and/or ABC Wheels did/do not exist as separate entities.”
19 (Reply 3.) Plaintiff has not put forth evidence to support this allegation, merely concluding
20 that “[t]he facts” support its argument. (*Id.*) Thus, the Court finds that piercing the
21 corporate veil is not appropriate here because there are not sufficient facts to demonstrate
22 a unity of interest between Mr. Moalemi and the companies. The Court next analyzes
23 whether Mr. Moalemi was personally involved in the allegedly infringing activity. *See*
24 *Gajo v. Chi. Brand*, No. 17-cv-380-EMC, 2017 WL 2473142, at *4 (N.D. Cal. June 8,
25 2017) (holding personal liability for trademark infringement can stem from either alter ego
26 liability *or* direct participation in the tort); *Orthokinetics, Inc. v. Safety Travel Chairs, Inc.*,
27 806 F.2d 1565, 1579 (Fed. Cir. 1986) (“[C]orporate officers who actively aid and abet their
28 corporation’s infringement may be personally liable for inducing infringement under [35

1 U.S.C.] § 271(b) regardless of whether the corporation is the alter ego of the corporate
2 officer.”).

3 2. *Personal Liability for Trademark Infringement*

4 Corporate officers are “personally liable for [a] corporation’s . . . trademark
5 infringements when they are a ‘moving, active conscious force’ behind the corporation’s
6 infringement.” *Novell, Inc. v. Unicom Sales, Inc.*, No. C-03-2785 MMC, 2004 WL
7 1839117, at *17 (N.D. Cal. Aug. 17, 2004) (citing cases). The officer must “personally
8 take part in infringing activities or specifically direct employees to do so.” *Transgo, Inc.*
9 *v. Ajac Transmission Parts Corp.*, 768 F.2d 1001, 1021 (9th Cir. 1985); *Hewlett-Packard*
10 *Co. v. Repeat-O-Type Stencil Mfg. Corp.*, No. C-92-3330 DLJ, 1995 WL 552168 (N.D.
11 Cal. Aug. 30, 1995) (“If an individual actively and knowingly caused the trademark
12 infringement, he is personally responsible. Specifically, a corporate officer who directs,
13 controls, ratifies, participates in, or is the moving force behind the infringing activity, is
14 personally liable for such infringement without regard to piercing of the corporate veil.”
15 (internal citation and quotations omitted)).

16 It is undisputed that Mr. Moalemi owns a company that operates at least one of the
17 accused websites. Mr. Moalemi testified he operates the username USArim on
18 Amazon.com and he writes the descriptions of products sold by USArim on Amazon.
19 (ECF No. 58-22, at 3.) He testified he sets the price for the wheels sold on Amazon. (*Id.*
20 at 6.) He testifies he instructs his employee (“John Doe”) what products to list and remove
21 on the USArim website. (ECF No. 58-19, at 13.) Mr. Moalemi clearly controlled the
22 company’s actions in posting products online, listing products on third party sites, and
23 running the website. As detailed above, at least some of the products Defendants list online
24 infringe Plaintiff’s trademark. Plaintiff has proven there is no disputed fact that Mr.
25 Moalemi’s involvement in the allegedly infringing activity is sufficient to find him
26 personally liable for the activity. The Court finds Mr. Moalemi may be found personally
27 liable for trademark infringement.

28 ///

1 3. *Personal Liability for Patent Infringement*

2 “[O]fficers of a corporation are personally liable for tortious conduct of the
3 corporation if they personally took part in the commission of the tort or specifically
4 directed other officers, agents, or employees of the corporation to commit the tortious act.”
5 *Orthokinetics*, 806 F.2d at 1579. As noted above, Mr. Moalemi testified he listed the
6 products on Amazon and directed others as it relates to listing products on his website
7 USARim.com. This shows he was personally involved in committing the acts, and thus
8 can be liable for patent infringement. The Court finds Mr. Moalemi may be found
9 personally liable for design patent infringement.

10 ***B. Entity Defendants***

11 The Court now determines whether the Entity Defendants are liable for
12 infringement. Defendants state “Infobahn International, Inc. was dissolved in 2011, A-Z
13 Wheels LLC was dissolved in 2013, Galaxy Wheels & Tires, LLC was dissolved in 2015,
14 and Eurotech Wheels was never a separate entity but simply was one of many trade names
15 used in the past.” (Opp’n 2 n.1.) Plaintiff acknowledges Infobahn was dissolved in 2012,
16 but state the USArim domain name was registered on behalf of “Eurotech” starting in June
17 2013. (“Pl. Facts,” ECF No. 58-2, ¶ 12; *see* Moalemi Depo. 3–4 (testifying that he operated
18 under the name Eurotech).) Mr. Moalemi testified he operated under USArim, and
19 USArim.com, which is “our bread and butter . . . our website.” (Moalemi Depo. 4.)
20 USArim.com “[s]tarted from Infobahn International” in 2010 or 2011. (*Id.*)

21 The lines between the various entities are blurred; some operated at certain times but
22 then blended into other entities, some of which dissolved. Mr. Moalemi stated his business
23 operated under many names because of the “nature of [the] business” and he hoped to
24 “attract as many people as we can.” (*Id.* at 3–4.) He operated under many names “just to
25 bring people in.” (*Id.* at 4.)

26 In *Penasquitos, Inc. v. Superior Court*, 812 P.2d 154 (Cal. 1991), the California
27 Supreme Court held that under California Corporations Code § 2010, a corporation may
28 be sued for actions taken after the corporation has dissolved. In *Penasquitos*, the court held

1 that post-dissolution claims against dissolved corporations can be brought with respect to
2 pre-dissolution, not post-dissolution, activities. “There is no legal barrier to a suit against
3 a dissolved corporation itself for injury or damage that is caused by the corporation’s
4 predissolution activities but occurs or is discovered after the dissolution.” *Id.* at 1194.

5 Plaintiff states that although Infobahn was dissolved in 2012, the domain name for
6 the USArim website was registered on behalf of Eurotech starting in June 2013. (Pl. Facts
7 ¶ 12.) Defendants do not seem to dispute this, only arguing “Eurotech Wheels was never
8 a separate entity but simply one of the many trade names used in the past.” (Opp’n 2.)
9 There also appears to be no dispute that USArim.com is still operating. Any claims
10 regarding actions taken by an Entity Defendants post-dissolution are barred under
11 *Penasquitos*. The Court finds the Entity Defendants may be found liable for any infringing
12 activity that occurred pre-dissolution.

13 CONCLUSION

14 For the foregoing reasons, the Court **GRANTS** Plaintiff’s Motion for Summary
15 Judgment in its entirety.¹¹

16 **IT IS SO ORDERED.**

17 Dated: August 13, 2018

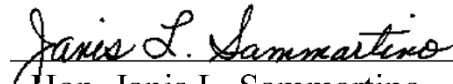
18 
19 Hon. Janis L. Sammartino
20 United States District Judge

21
22
23
24
25
26
27 ¹¹ Plaintiff’s complaint alleges infringement of multiple marks and patents, and the Motion for Summary
28 Judgment was only partial and covered the claims discussed herein, Plaintiff **SHALL** file a notice within
ten (10) days of the date this Order is docketed informing the Court how it wishes to proceed on the
remaining claims.