

IN THE UNITED STATES DISTRICT COURT  
FOR THE DISTRICT OF COLORADO  
Judge R. Brooke Jackson

Civil Action No 17-cv-02097-RBJ

REALTIME ADAPTIVE STREAMING LLC,

Plaintiff,

v.

SLING TV L.L.C.,  
SLING MEDIA, L.L.C.,  
ECHOSTAR TECHNOLOGIES L.L.C.,  
DISH NETWORK L.L.C., and  
ARRIS GROUP, INC.,

Defendant.

---

**MARKMAN ORDER**

---

This patent infringement lawsuit involves data compression. *See generally* Second Amended Complaint, ECF No. 32. At the parties' request, the Court conducted a "Markman" hearing on December 19, 2018. The Court's interpretation of the key terms is set forth in this order.

**BACKGROUND**

There are two asserted patents in this case: U.S. Patent Nos. 8,867,610 ("the '610 patent") and 8,934,535 ("the '535 patent") (collectively, "Asserted Patents"). Plaintiff Realtime is the owner of both patents. The '610 patent is titled "System and Methods for Video and Audio Data Distribution," whereas the '535 patent is titled "stem and Methods for Video and Audio Data Storage and Distribution." The specifications for both patents are virtually identical.

The Asserted Patents concern data compression and decompression algorithms. The patents are directed to selecting a compression scheme based on characteristics of the digital data being compressed. The Asserted Patents attempt to optimize compression time for digital files to prevent problems such as download delay, data buffering, and reduced system speeds. As depicted in Figure 1, the controller selects a compression algorithm from a database of algorithms based on the data type and throughput requirements.

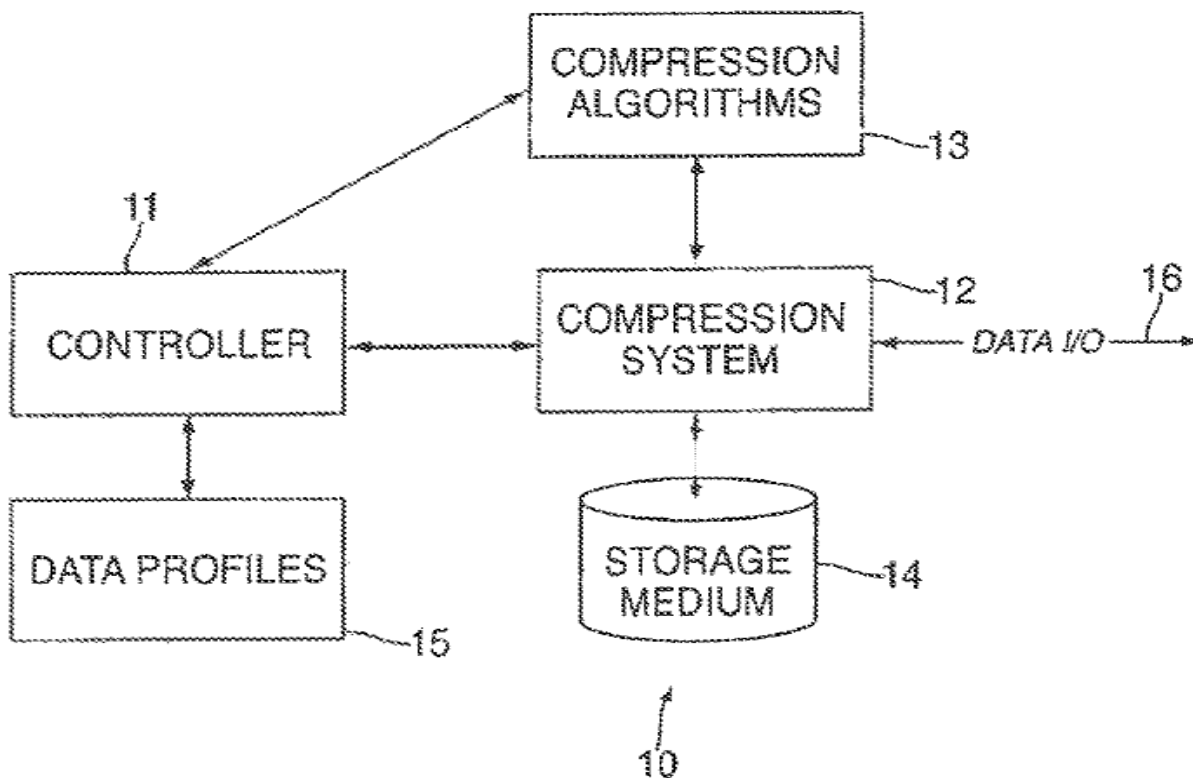

FIG. 1

To select the optimal compression algorithm, the Asserted Patents first assign a data or access profile to the user based on the frequency that the data is accessed or written. Then, the Asserted Patents assign a compression algorithm to each profile. A symmetrical compression

algorithm would be optimal when the profile has a similar read to write ratio (meaning the number of reads and writes is balanced). In contrast, an asymmetrical compression algorithm is preferred when the profile writes often but reads seldom, or vice versa. In the former scenario, the preferred algorithm would compress quickly and decompress slowly. The opposite is true for the latter scenario.

Plaintiff asserts that defendants have infringed and continue to infringe on the Asserted Patents. The dispute has been set for a five-day jury trial commencing on December 16, 2019. However, the sole focus for this order is claim construction. The parties have narrowed their claim construction disputes to eight terms or groups of related terms. They have expressed their respective positions in a joint claim construction chart [ECF No. 121], claim construction briefs [ECF Nos. 127, 134, and 135], and in their presentations at the Markman hearing [ECF Nos. 144, 146]. On December 19, 2018 this Court conducted the hearing. At the parties' request, each side asked for 1.75 hours per side to make their arguments. In that time, we covered four of the eight terms: access profile, throughput of a communication channel, asymmetric compressor, and compressor. The parties agreed to rest on their written presentations for the remaining terms.

### **LEGAL PRINCIPLES**

Claim construction is a matter of law for the Court. *Markman v. Westview Instruments, Inc.*, 517 U.S. 370, 384–91 (1996). The objective is to give disputed terms in a patent claim the meaning that a person of ordinary skill in the relevant art would have given them at the time of the invention unless the patent applicant has clearly and unambiguously defined the terms differently. *See, e.g., Honeywell Int'l Inc. v. Universal Avionics Sys. Corp.*, 493 F.3d 1358, 1361 (Fed. Cir. 2007).

The Court principally considers “intrinsic evidence,” i.e., the words of the claim itself in the context of the entire patent including as relevant the specification and the prosecution history. *Phillips v. AWH Corp.*, 415 F.3d 1303, 1313–17 (Fed. Cir. 2005), *cert. denied*, 546 U.S. 1170 (2006). The specification is “the single best guide to the meaning of a disputed term.” *Vitrionics Corp. v. Conceptoronic, Inc.*, 90 F.3d 1576, 1582 (Fed. Cir. 1996). The court may not, however, read limitations from the specification, particularly the disclosed embodiments, into the claim. *Phillips*, 415 F. 3d at 1323–24. The district court may consult extrinsic evidence if it is necessary “to understand, for example, the background science or the meaning of a term in the relevant art during the relevant time period.” *Teva Pharm. USA, Inc. v. Sandoz, Inc.*, 135 S. Ct. 831, 841 (2015).

## **DISPUTED CLAIM TERMS**

### **I. ACCESS PROFILE [Claims ‘535 pat., Cl. 1 and 14].**

#### **A. Plaintiff’s Proposed Interpretation.**

No construction is required beyond the plain and ordinary meaning of the term as determined by one of ordinary skill in the art based upon the claim being considered in context.

#### **B. Defendants’ Interpretation.**

The term “access profile” is a “profile containing information about the number or frequency of reads and writes.”<sup>1</sup>

---

<sup>1</sup> Originally the DISH and Sling defendants did not seek construction for this term; only defendant Arris did. ECF No. 127 at 2. But in the reply brief and at the Markman hearing, the remaining defendants agreed with Arris’s proposed construction. As such, I refer to the proposed construction as “defendants’ interpretation.”

**C. Discussion.**

Claim 1 of the '535 patent claims

A method, comprising:

determining a parameter or attribute of at least a portion of a data block having audio or video data;

selecting an *access profile* from among a plurality of access profiles based upon the determined parameter or attribute; and

compressing at least the portion of the data block with one or more compressors using asymmetric data compression and information from the selected access profile to create one or more compressed data blocks, the information being indicative of the one or more compressors to apply to the at least the portion of the data block.

'535 pat. at col. 20:29–41 (emphasis added).

Defendants argue that the '535 patent consistently describes different “access profiles” for data based on information about the frequency a user reads (meaning opening a document) and writes (meaning saving a document) the data. ECF No. 127 at 2. To illustrate, defendants cite the chart at the bottom of column 12 of the '535 patent.

Access Profile	Example Data Types	Compression Algorithm	Compressed Data Characteristics	Decompression Algorithm
1. Write few, Read many	Operating systems, Programs, Web sites	Asymmetrical (Slow compress)	Very high compression ratio	Asymmetrical (Fast decompress)
2. Write many, Read few	Automatically updated inventory database	Asymmetrical (Fast compress)	Very high compression ratio	Asymmetrical (Slow decompress)
3. Similar number of Reads and Writes	User generated documents	Symmetrical	Standard compression ratio	Symmetrical

‘535 pat. at col. 12. This chart, defendants argue, constitutes intrinsic evidence to support their proposed interpretation. *Id.* at 3.

In response, plaintiff argues that claim construction for “access profile” is unwarranted because the term is readily understandable to a person of ordinary skill in the art, and the term is used in the specification according to its plain meaning. ECF No. 134 at 1. Moreover, there is no clear lexicography or disavowal of the plain meaning of the term to warrant claim construction. *Id.* In response to defendants’ proposed construction, plaintiff asserts that defendants improperly import limitations from the specifications into the claims. *Id.* at 2. And, plaintiff argues that defendants’ proposed construction excludes disclosed embodiments. *Id.*

I disagree with plaintiff that the plain and ordinary meaning of “access profile” is a term that a person of ordinary skill in the art would readily understand. This is an obscure term that should be construed. However, I cannot accept defendants’ proposed construction, as that proposal attempts to define an obscure term with an obscure definition. Instead, I choose to

adopt a construction that tracks the language of the ‘535 patent itself. The ‘535 patent’s specification provides a sufficient construction for the disputed term: “[t]he access profiles comprise information that enables the controller to select a suitable compression algorithm that provides a desired balance between execution speed (rate of compression) and efficiency (compression ratio).” ‘535 pat. at col. 8:8–12.

At the Markman hearing, I proposed this very construction to the parties. Plaintiff generally agreed with my proposal should I feel compelled to construe the term. Defendants’ primary issue with my construction was that it was too broad, and that the use of the word information would be confusing to the jury. Defendants suggested “saves and opens” instead.

Defendants’ position is a little odd considering defendants’ proposal also contained the word information. Nonetheless, I agree with defendants that the word information could be further clarified to assist the jury. Based on intrinsic evidence—as depicted in the “access profile” chart above—I choose to use the words reads and writes as opposed to saves and opens. I also take comfort in the fact that defendants stated at the Markman hearing “reads” is synonymous with “opens,” and “writes” is synonymous with “saves.”

**D. Court’s Construction.**

Therefore, the Court construes the term “access profile” to mean “comprising the read and write data that enables the controller to select a suitable compression algorithm that provides a desired balance between execution speed (rate of compression) and efficiency (compression ratio).”

**II. THROUGHPUT OF A COMMUNICATION CHANNEL [Claims ‘610 pat., Cl. 1, 9, 12–14].**

**A. Plaintiff’s Proposed Interpretation.**

No construction is required beyond the plain and ordinary meaning of the term as determined by one of ordinary skill in the art based upon the claim being considered in context.

**B. Defendants’ Proposed Interpretation.**

“Throughput of a communication channel” means the “number of pending transmission requests over a communication channel.”

**C. Discussion.**

Claim 1 of the ‘610 patent claims

A method, comprising:

determining, a parameter or an attribute of at least a portion of a data block having video or audio data;

selecting one or more compression algorithms from among a plurality of compression algorithms to apply to the at least the portion of the data block based upon the determined parameter or attribute and a *throughput of a communication channel*, at least one of the plurality of compression algorithms being asymmetric; and

compressing at least the portion of the data block with the selected compression algorithm after selecting the one or more, compression algorithms.

‘610 pat. at col. 20: 2–13 (emphasis added).

Neither party contends that “a communication channel” requires construction. Instead, the issue revolves around the meaning of “throughput.” Defendants concede that “throughput” is used in the specification in various contexts, but the term only appears once in the context of a



“communication channel.” ECF No. 127 at 4. Defendants are concerned that not defining “throughput” will allow plaintiff to define the term as “bandwidth”—a definition the patent examiner purportedly rejected. *Id.* at 4–5.

In response, plaintiff alleges that the claims and specification use the term “throughput” in its ordinary sense, which means “data rate or usage.” ECF No. 134 at 2. Because plaintiff did not clearly redefine “throughput” in the specification, there is no clear and unmistakable disclaimer which would limit the term to defendants’ narrow construction. *Id.* at 3. Moreover, plaintiff argues that defining “throughput” as the “number of pending transmission requests over a communication channel” is just one example of a method to track data rate or usage; there are numerous other methods to track data rate or usage. *Id.*

I agree that the Asserted Patents use “throughput” inconsistently. For example, the abstract of both patents reads:

Data compression and decompression methods for compressing and decompressing data based on an actual or expected throughput (bandwidth) of a system. In one embodiment, a controller tracks and monitors the throughput (data storage and retrieval) of a data compression system and generates control signals to enable/disable different compression algorithms when, e.g., a bottleneck occurs so as to increase the throughput and eliminate the bottleneck.

When I see the term “throughput” followed by a parenthetical “bandwidth,” I would normally conclude that throughput and bandwidth are synonyms of each other. However, in this case, the next sentence seemingly defines throughput in a different manner.

Although the Asserted Patents use “throughput” inconsistently, it is true that the patents use the term only once in the context of a “communication channel.” Defendants refer to this singular passage in the summary of the invention as an express definition of “throughput of a communication channel.” It reads: “In another aspect, the system comprises a data transmission

controller for controlling the compression and transmission of compressed data, as well as the decompression of compressed data received over a communication channel. The system *throughput* tracked by the controller comprises *a number of pending transmission requests over the communication channel.*” ‘535 pat. at col. 8:21–27 (emphasis added).

I find that “throughput of a communication channel” does not have a plain and ordinary meaning. Plaintiff wants me to leave this term undefined or use “bandwidth” to define throughput. But as defendants pointed out in the Markman hearing, bandwidth itself carries multiple meanings, such as a range of frequencies, memory reads and writes per unit time, processor command execution rate, the number of traces on a bus, or the capacity to perform a task. Having concluded that this term lacks a plain and ordinary meaning, plaintiff’s argument that the ‘535 patent did not include a disclaimer is unavailing because there is nothing to disclaim. As such, the intrinsic evidence must control. I also note that I don’t find “communication channel” particularly useful, but at the hearing, both sides agreed that its use should be included in the definition. Therefore, the Court adopts defendants’ construction of the term “throughput of a communication channel” because it is supported by the intrinsic evidence.

**D. Court’s Construction.**

“Throughput of a communication channel” means the “number of pending transmission requests over a communication channel.”

**III. ASYMMETRIC COMPRESSOR(S) [Claims ‘535 pat., Cl. 12, 15–16, 24] /  
ASYMMETRIC DATA COMPRESSION [Claims ‘535 pat., Cl. 1, 10] / ASYMMETRIC  
COMPRESSION ALGORITHM/COMPRESSION ALGORITHMS BEING  
ASYMMETRIC [Claims ‘610 pat., Cl. 1, 9] / ASYMMETRIC [Claims ‘610 pat., Cl. 6, 16].**

**A. Plaintiff’s Proposed Interpretation.**

No construction is required beyond the plain and ordinary meaning of the term as determined by one of ordinary skill in the art based upon the claim being considered in context. In the alternative, if this Court determines that claim construction is necessary, the term should be construed as “a compression algorithm in which the execution times for compression and decompression differ significantly.” Moreover, plaintiff makes clear that it believes the term is not indefinite.

**B. Defendants’ Proposed Interpretation.**

Defendants allege that the term means “a compression algorithm in which the execution time for compression and decompression differ significantly,” which renders the claims indefinite under *Halliburton Energy Servs., Inc. v. M-I LLC*, 514 F.3d 1244 (Fed. Cir. 2008).

**C. Discussion.**

This is the sole claim term that the parties agree on the construction. But they disagree on whether this construction renders the claims indefinite. In *Halliburton Energy Servs., Inc. v. M-I LLC*, 514 F.3d 1244, 1256 (Fed. Cir. 2008), the Federal Circuit held that the defendant provided clear and convincing evidence that the term “fragile gel” was indefinite. The patent at issue in *Halliburton* “relate[d] to oil field drilling fluids that [were] fragile gels.” *Id.* at 1246.

The court determined that the term was indefinite because “an artisan would not know from one well to the next whether a certain drilling fluid was within the scope of the claims because a wide variety of factors could affect adequacy (formation geology, wellbore size, depth, angle, etc.)” *Id.* at 1254–55.

Here, defendants argue that decompression execution times depend on the client device’s computing power. ECF No. 127 at 6–7. Thus, whether defendants infringe on the Asserted Patents depends on the speed of the device decompressing the data. Defendants’ expert, Dr. Alan Bovik, opined that compression run-time may vary depending on the end-user’s hardware, memory, or peripherals. Bovik Decl., ECF No. 135-1 at ¶¶33–35. He opined that such factors would lead to impossible infringement determinations because an artisan would be forced to make a separate infringement determination each time. *Id.* at ¶¶35–37.

Plaintiff responds by arguing that a person of skill in the art would understand that the algorithms in question are either always asymmetrical or always symmetrical, regardless of the specific hardware or software used. ECF No. 134 at 5; *see also* Kenneth Zeger Decl., ECF No. 134-1 at ¶20. Plaintiff further defends the definitiveness of its claims by arguing that the specification provides “examples sufficient” for a person of ordinary skill in the art to determine whether the claim limitation is present. ECF No. 134 at 7 (citing *Halliburton*, 514 F.3d at 1256 (internal citations omitted)). To illustrate, the specification states that “asymmetrical compression algorithms include dictionary-based compression schemes such as Lempel-Ziv.” ‘535 pat. at col. 10:3–4. Similarly, the specification states that “[e]xamples of symmetrical algorithms include table-based compression schemes such as Huffman.” ‘535 pat. at col. 10:8–9.

Despite the brief arguments that both sides presented at the Markman hearing, I reserve judgment on my ruling regarding the indefiniteness of this claim. Defendants indicated that the issue was not fully briefed and asked that I reserve judgment. Instead, they stated that they would move for summary judgment on this issue. Because plaintiff did not object to defendants' request, I will reserve judgment on the indefiniteness argument until defendants file for summary judgment.

**D. Court's Construction.**

An "asymmetric" compression algorithm is "a compression algorithm in which the execution time for compression and decompression differ significantly." Whether this construction renders the claim indefinite will be decided on summary judgment should defendants file such motion.

**IV. COMPRESSOR [Claims '535 pat., Cl. 1, 8, 10, 12, 14–16].**

**A. Plaintiff's Proposed Interpretation.**

No construction is required beyond the plain and ordinary meaning of the term as determined by one of ordinary skill in the art based upon the claim being considered in context. In the alternative, if this Court determines that claim construction is necessary, the term should be construed as "data compression encoder."

**B. Defendants' Proposed Interpretation.**

Defendants propose the following construction: "Means-plus-function element to be construed in accordance with pre-AIA 35 U.S.C. § 112, ¶ 6. Function: compressing the at least the portion of the data block. Structure: Controller 11 in Fig. 1 or [Digital Signal Processor ("DSP")] or Processor 121 in Fig. 3 running any one of the following compression algorithms:

arithmetic coding, dictionary compression, table-based compression, Huffman coding, and run-length coding.”

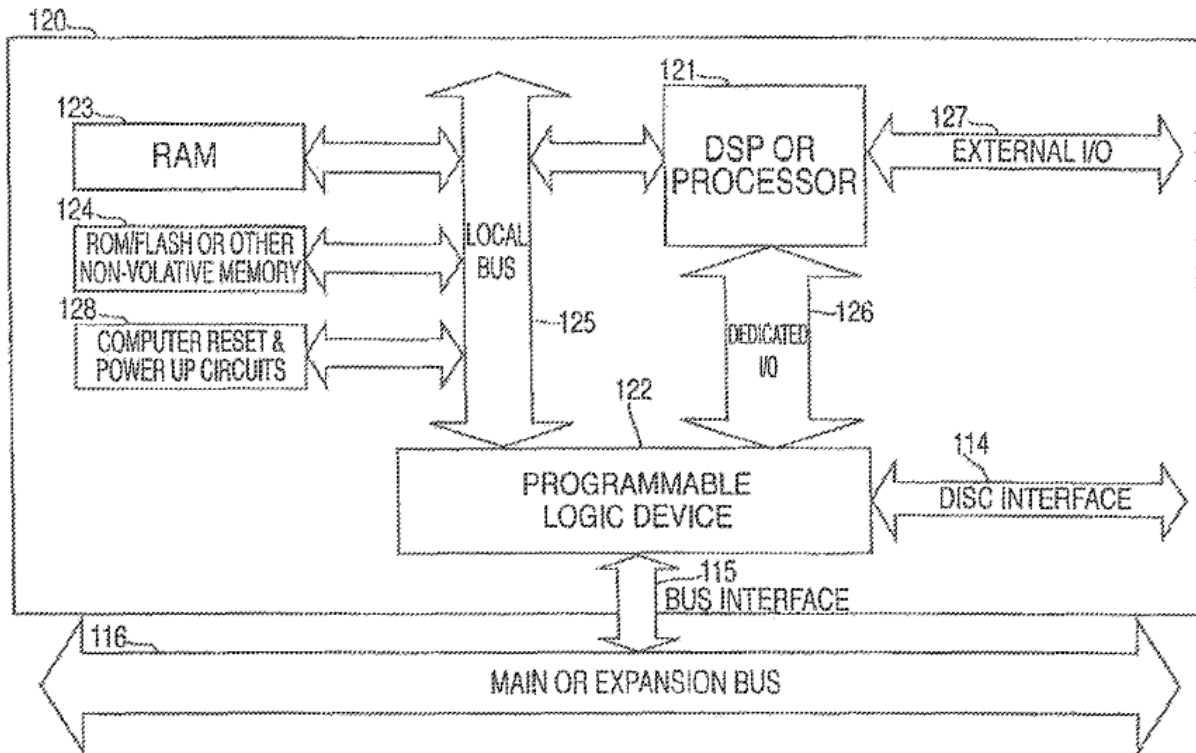

FIG. 3

**C. Discussion.**

The core dispute regarding the construction of the term “compressor” is whether means-plus-function claiming applies. 35 U.S.C. § 112, ¶ 6 reads:

An element in a claim for a combination may be expressed as a means or step for performing a specified function without the recital of structure, material, or acts in support thereof, and such claim shall be construed to cover the corresponding structure, material, or acts described in the specification and equivalents thereof.

This provision allows “patentees to express a claim limitation by reciting a function to be performed rather than by reciting structure for performing that function, while placing specific

constraints on how such a limitation is to be construed . . . .” *Williamson v. Citrix Online, LLC*, 792 F.3d 1339, 1347 (Fed. Cir. 2015). Under prior Federal Circuit law, the court all but required a patentee to use the term “means” to invoke § 112, ¶ 6. *Id.* at 1349 (collecting caselaw). The absence of “means” created a “strong” presumption that mean-plus-function claiming did not apply. *Id.* However, the *Williamson* court declared a modified, relaxed rule:

The standard is whether the words of the claim are understood by persons of ordinary skill in the art to have a sufficiently definite meaning as the name for structure. When a claim term lacks the word “means,” the presumption can be overcome and § 112, para. 6 will apply if the challenger demonstrates that the claim term fails to “recite sufficiently definite structure” or else recites “function without reciting sufficient structure for performing that function.”

*Id.* (internal citations omitted).

In this case, defendants admit that the claim term “compressor” does not include the word “means.” ECF No. 127 at 8. Nonetheless, under the new *Williamson* standard, defendants argue that § 112, ¶ 6 applies because the specification fails to explain what structure performs the function of compressing data. *Id.* at 8–9. Rather, defendants assert that the patent speaks in generic terms and solely focuses on the function—compressing data—without defining the structure that completes the function. *Id.*

Plaintiff predictably argues that § 112, ¶ 6 doesn’t apply to the Asserted Patents because the claim term did not recite “means.” ECF No. 134 at 8. And then plaintiff argues that defendants failed to meet its burden under the *Williamson* standard because defendants failed to refute plaintiff’s expert, who concluded that a compressor is a “data compression encoder, which is a class of known structure.” Zeger Decl., ECF No. 134-1 at ¶¶21–24.

For this claim term only, I find it useful to first turn to the expert opinions. As I mentioned in the previous paragraph, plaintiff’s expert opined that a person of ordinary skill in

the art would understand the term compressor to mean a data compression encoder structure. Zeger Decl., ECF No. 134-1 at ¶21. According to Dr. Zeger, a compressor is a subset of the class within the broader class of encoder structures, which include hardware, firmware, or software structures that encode digital data. *Id.* Dr. Zeger also cited the specification, the claims, and other incorporated patents to support his assertion that the claim term recites sufficiently definite structure. *Id.* ¶22; *see also* ‘535 claim 14.

Defendants provide no testimony from a person of ordinary skill in the art to refute Dr. Zeger’s interpretation of the term. Despite the opportunity to do so, Dr. Bovik did not respond to Dr. Zeger’s proposed construction of the term “compressor,” nor did Dr. Bovik provide an opinion that the term compressor fails to connote sufficient structure to a person of ordinary skill in the art. Instead of refuting Dr. Zeger’s opinion with its own person of ordinary skill in the art, defendants argue that Dr. Zeger’s report is unsupported and conclusory.

I agree that Dr. Zeger doesn’t cite to manuals or articles in this portion of his opinion, but he did thoroughly explain his reasoning to include specific examples of encoder structures. *See* Zeger Decl., ECF No. 134-1 at ¶21. What I am left to decide is whether a person of ordinary skill in the art would find the term “compressor” to be a definite structure. And here, I have the opinion of exactly one person of ordinary skill in the art.

As such, I accept Dr. Zeger’s assertion that the specification recites a sufficiently definite structure. My decision also is supported by intrinsic evidence. Claim 14 of the ‘535 patent, which states that “compressors utilize at least one slow compress encoder and at least one fast decompress decoder,” suggest that “compressors” are data compression encoders. Further, defendants want me to rule that plaintiff’s definition of an encoder—which it construes as



"hardware, firmware, or software structures that encode digital data"—is broad and fails to identify any particular structure. But Federal Circuit precedent does not demand so much from a patentee. *See Skky, Inc. v. MindGeek, s.a.r.l.*, 859 F.3d 1014, 1019 (Fed. Cir. 2017) (holding that a claim recites sufficient structure “if the claim term is used in common parlance or by persons of skill in the pertinent art to designate structure, even if the term covers a broad class of structures and even if the term identifies the structures by their function”). Again, plaintiff’s expert stated that the term is a subset of a class of known structure, and he cited intrinsic evidence to support his opinion. Without a rebuttal from a person of skill in the pertinent art, I will follow the opinion of the lone expert.

**C. Court’s Construction.**

Accordingly, the Court construes the term “compressor” to be a “data compression encoder.”

**V. COMPRESSING/COMPRESSED/COMPRESSION [Claims ‘610 pat., Cl. 1, 2, 6, 8-14, 16, 18; ‘535 pat., Cl. 1-2, 4-6, 8, 10-12, 14-17, 19, 21-22].**

**A. Plaintiff’s Proposed Interpretation.**

The term “compressing / compressed /compression” means “[representing / represented / representation] of data with fewer bits.”

**B. Defendants’ Proposed Interpretation.**

No construction is required beyond the plain and ordinary meaning of the term as determined by one of ordinary skill in the art based upon the claim being considered in context.

In the alternative, if this Court determines that claim construction is necessary, the term

“compressing / compressed /compression” means “[reduction of / reducing / reduce] the amount of data required to process, transmit, or store a given quantity of information.”

**C. Discussion.**

Claim 1 of the ‘610 patent claims

A method, comprising:

determining, a parameter or an attribute of at least a portion of a data block having video or audio data;

selecting one or more compression algorithms from among a plurality of compression algorithms to apply to the at least the portion of the data block based upon the determined parameter or attribute and a throughput of a communication channel, at least one of the plurality of compression algorithms being asymmetric; and

*compressing* at least the portion of the data block with the selected compression algorithm after selecting the one or more, compression algorithms.

‘610 pat. at col. 20:2–13 (emphasis added).

Defendants argue that their proposed construction closely tracks the specification, which states that “[d]ata compression is widely used to reduce the amount of data required to process, transmit, or store a given quantity of information.” ‘535 pat. at col. 2:44–46. Defendants then argue that plaintiff’s proposal is unsupported by the intrinsic record, and that the words “bits” simply adds ambiguity to the term. ECF No. 127 at 10.

In response, plaintiff asserts that its proposed construction simply uses the term in its ordinary sense. ECF No. 134 at 12. As evidence, plaintiff also cites to the ‘535 patent specification. *Id.* The relevant parts of the specification reads: “[D]ata compression economizes on data storage . . . by *representing information more efficiently*. . . . Lossy data compression techniques provide for an inexact *representation of the original uncompressed data* such that the

decoded (or reconstructed) data differs from the original unencoded/uncompressed data. . . . [L]ossless data compression techniques provide an exact *representation of the original uncompressed data.*” ‘535 pat. at col. 4:23–53 (emphasis added).

To start, I find that the term “compressing / compressed / compression” requires construction. It seems plain to me from the briefs and presentations that the term lacks a plain and ordinary meaning. As such, I must decide on a construction that is supported by intrinsic evidence. Here, I find plaintiff’s construction persuasive. The specification uses the term in its ordinary sense, which is to represent data with fewer bits. See ‘535 pat. at col. 4:23–53. Moreover, plaintiff cited seven Realtime cases in which the respective parties disputed the meaning of the term “compressing / compressed / compression.” The defendants in those cases either stipulated to Realtime’s proposed construction, or the court construed the term in Realtime’s favor.<sup>2</sup> While I am not bound by the construction of “compressing / compressed / compression” previously agreed upon in different lawsuits involving different defendants, I find it persuasive. This is especially true since plaintiff represented that the patents at issue in those cases are incorporated by reference in the Asserted Patents. ECF No. 144-1 at 37. Further, defendants fail to present a merit-based argument for why this Court shouldn’t construe the term similarly. Instead, defendants simply argue that I am not bound by those decisions. See ECF No. 146-1 at 57. Accordingly, I elect to adopt plaintiff’s construction.

---

<sup>2</sup> See *Realtime Data LLC v. Actian Corp.*, No. 6:15-cv-00463-RWS-JDL, D.I. 362 at 39 (E.D. Tex. July 28, 2016); *Realtime Data LLC v. Packeteer, Inc.*, No. 6:08-cv-00144-LED-JDL, Dkt. No. 371-2 at 64 (E.D. Tex. June 22, 2009); *Realtime Data LLC v. Morgan Stanley*, No. 1:11-cv-06703-KBF, Dkt. No. 89 at 4 (S.D.N.Y. July 9, 2012); *Realtime Data LLC v. Teradata Op., Inc.*, No. 2:16-CV-02743-AG-FFM, Dkt. No. 42 (C.D. Cal. Jan. 24, 2017); *Realtime Data LLC v. Synacor, Inc.*, No. 6:17-CV-00126-RWS-JDL, Dkt. (E.D. Tex. Apr. 25, 2018); *Realtime Data LLC v. EchoStar Corp. & Hughes Network Sys., LLC*, No. 6:17-cv-00084-JDL, Dkt. No. 104 (E.D. Tex. Apr. 25, 2018); *Realtime Data LLC v. Rackspace US, Inc.*, No. 6:16-cv-00961-RWS-JDL, Dkt. No. 183 (E.D. Tex. June 14, 2017).

**D. Court's Construction.**

“Compressing / compressed /compression” means “[representing / represented / representation] of data with fewer bits.”

**VI. ALGORITHM [Claims ‘610 pat., Cl. 1, 6, 9, 12–14, 16].**

**A. Plaintiff's Proposed Interpretation.**

No construction is required beyond the plain and ordinary meaning of the term as determined by one of ordinary skill in the art based upon the claim being considered in context. In the alternative, if this Court determines that claim construction is necessary, the term algorithm should be construed as “a set of rules.”

**B. Defendants' Proposed Interpretation.**

Algorithm means “a set of rules that define one or more parameters that can be varied.”

**C. Discussion.**

Defendants argue that specification defined “algorithm” when it stated, “[m]any compression algorithms define one or more parameters that can be varied, either dynamically or a-priori, to change the performance characteristics of the algorithm.” ECF No. 127 at 11 (quoting ‘535 pat. at col. 1:32–35). Defendants suggest its construction tracks the specification because the specification explicitly contemplates varying the parameters of algorithms to change their performance characteristics. ECF No. 127 at 11. Defendants also point to extrinsic evidence by citing two dictionaries. According to the dictionaries’ definitions, defendants argue that adjusting parameters—such as speed or accuracy of the compression—within a “set of rules” does not create a new algorithm. *Id.*

In response, plaintiff argues that the intrinsic record doesn't support defendants' narrow construction because the quoted language refers to "compression algorithms," not a basic algorithm, which needs no construction. ECF No. 134 at 12. However, plaintiff is willing to agree to "a set of rules" as the construction so long as defendants agree to drop the additional importations. *Id.* at 13. Plaintiff argues that defendants improperly imported limitations from the background section of the '535 patent in which plaintiff contends that the single sentence was merely a description of the performance of some or many algorithms; it was not an explicit redefinition of the term. *Id.*

Both parties cite to extrinsic evidence for support. Defendants' expert, Dr. Bovik, stated that each example algorithm cited by plaintiff has parameters that can be varied. ECF No. 135-1 at 9. Dr. Bovik did not, however, opine on the plain meaning of the term. In contrast, plaintiff's expert, Dr. Zeger, stated that "algorithm" is a plain term that is readily understandable to a person of ordinary skill in the art. Zeger Decl., ECF No. 134-1 at 10. He opined that the term generally means "a set of rules or steps." *Id.* Moreover, Dr. Zeger stated that defendants' additional language is inconsistent with the plain meaning of "algorithm" because it is not necessarily applicable to all algorithms. *Id.*

I find that a person of ordinary skill in the relevant art would construe "algorithm" as "a set of rules." The single sentence in the specification that defendants cite does not persuade me. That sentence refers to "many compression algorithms," not all algorithms. '535 pat. at col. 1:32-35. Moreover, the argument that plaintiff did not identify a single disclosed algorithm that does not have variable parameters fails. The Federal Circuit has stated that, absent clear intention from the patentee, it is improper to "import limitations into claims from examples or

embodiments appearing only in a patent's written description, even when a specification describes very specific embodiments of the invention or even describes only a single embodiment . . . .” *JVW Enters., Inc. v. Interact Accessories, Inc.*, 424 F.3d 1324, 1335 (Fed. Cir. 2005). Lastly, I agree with plaintiff that it did not make a clear and unmistakable disclaimer of the scope of a claim when it discussed “many compression algorithms.” The opposite is true; it explicitly made that statement regarding only some algorithms. As such, I am satisfied with the first half of defendants’ proposed construction, but defendants’ additional limitation lacks intrinsic and extrinsic support.

**D. Court’s Construction.**

“Algorithm” means “a set of rules.”

**VII. FILE [Claims ‘535 pat., Cl. 3, 4, and 11].**

**A. Plaintiff’s Proposed Interpretation.**

No construction is required beyond the plain and ordinary meaning of the term as determined by one of ordinary skill in the art based upon the claim being considered in context. In the alternative, if this Court determines that claim construction is necessary, the term file should be construed as an “executable program and/or data object.”

**B. Defendants’ Proposed Interpretation.**

File means a “collection of executable programs and/or various data objects that occur in a variety of lengths and that are stored within a data storage device.”

**C. Discussion.**

There are two exceptions to the general rule that disputed terms should be given the meaning that a person of ordinary skill in the relevant art would have given them at the time of

the invention. The first exception applies “when a patentee sets out a definition and acts as his own lexicographer.” *Thorner v. Sony Comput. Entm't Am. LLC*, 669 F.3d 1362, 1365 (Fed. Cir. 2012). “To act as its own lexicographer, a patentee must ‘clearly set forth a definition of the disputed claim term’ other than its plain and ordinary meaning.” *Id.* (quoting *CCS Fitness, Inc. v. Brunswick Corp.*, 288 F.3d 1359, 1366 (Fed. Cir. 2002)). The patentee must “clearly express an intent to redefine the term.” *Id.* (internal citation and quotation marks omitted). The second exception applies when a “patentee disavows the full scope of a claim term either in the specification or during prosecution.” *Id.*

Defendants argues that the first exception applies here. Defendants points to the ‘535 patent in which the specification states, “Files are collections of executable programs and/or various data objects. Files occur in a wide variety of lengths and must be stored within a data storage device.” ‘535 pat. at col. 5:60–63. These two sentences, defendants allege, constitute plaintiff’s act of redefining the term “file.”

Defendants’ argument is unpersuasive for two reasons. First, plaintiff has not clearly expressed an intent to refine the term. Federal Circuit caselaw typically requires more than describing or explaining the term in the background description of the problem within the current art. *See Astrazeneca AB v. Mutual Pharm. Co.*, 384 F.3d 1333, 1339 (Fed. Cir. 2004) (holding that patentee’s declaration that a term is “defined” in the specification is a “strong signal of lexicography”). Second, the language defendants rely on describes “files,” not “file.” This does not meet the “exacting” standard required to redefine a term outside of its plain and ordinary meaning. *See Thorner*, 669 F.3d at 1366. And, I agree with plaintiff that the plain meaning of the singular term file may include executable programs or data objects, but not necessarily a

“collection” of them. *See* ECF No. 134 at 14; Zeger Decl., ECF No. 134–1 at 12. For those three reasons, I find that plaintiff did not redefine “file” in the specification.

**D. Court’s Construction.**

The Court agrees with plaintiff and finds that no construction is required. The plain and ordinary meaning of the term can be determined by one of ordinary skill in the art from the word itself.

**VIII. DATA BLOCK [Claims ‘610 pat., Cl. 1, 2, 8–14, 18; ‘535 pat., Cl. 1, 2–6, 8–12, 14–17, 19, 21–22, 24].**

**A. Plaintiff’s Proposed Interpretation.**

Data block means “[a] single unit of data, which may range in size from individual bits through complete files or collection of multiple files.”

**B. Defendants’ Proposed Interpretation.**

No construction is required beyond the plain and ordinary meaning of the term as determined by one of ordinary skill in the art based upon the claim being considered in context.

**C. Discussion.**

Claim 1 of the ‘610 patent reads: “A method, comprising: determining, a parameter or an attribute of at least a portion of a data block having video or audio data . . . .” Defendants argue that “data block” has a commonly understood meaning in the art as a block of data, and that the term should be construed according to its plain meaning. They contend that plaintiff’s interpretation adds no clarity because “single unit of data” is written in the singular, and the word “unit” does not help to clarify the word “block.” ECF No. 127 at 13. Next, defendants argue that plaintiff’s proposed construction “risks that a single ‘unit of data’ may itself change in size



and still satisfy different limitations of the same claim.” *Id.* Defendants allege that this is improper because a “data block” must remain consistent throughout the claim. *Id.* Finally, defendants argue that an individual bit cannot be “compressed” as required by plaintiff’s proposed construction for “compression.” *Id.*

In response, plaintiff states that its proposed construction is consistent with the intrinsic record because both patents incorporate by reference another Realtime patent—‘024 patent—which states that data blocks “may range in size from individual bits through complete files or collections of files.” ECF No. 134 at 15. To address defendants’ three arguments, plaintiff argues that its construction is helpful because it clarifies that if the data is two bits or an entire file, it is a contiguous “single unit of data.” *Id.* Next, responding to defendants’ second argument, plaintiff suggests that just because a claimed invention can operate on data blocks of different sizes does not mean that one can point to different data blocks to satisfy the limitations of the claim. *Id.* Lastly, plaintiff dismisses defendants’ final argument as a logical fallacy by arguing that nothing in either patent or the law requires this Court to assume that every data block must be compressed. *Id.*

I find that plaintiff’s construction is consistent with the intrinsic evidence as well as the ordinary meaning of the term. Plaintiff’s construction tracks the language found in the ‘024 patent. Plaintiff’s expert, Dr. Zeger, stated in his declaration that the ‘024 patent uses the term in its plain and ordinary sense. Dr. Zeger also declared that a person of ordinary skill in the art would define data block as a “unit of digital data of a fixed or variable size, depending on the designer of the system that uses data blocks.” Zeger Decl., ECF No. 134-1 at 12. He further opined that there are systems that describe blocks that range in size from just a few bits to tens of

thousands of bytes. *Id.* at 13. Even assigning Dr. Zeger’s opinion less weight as required by prevailing caselaw, I am convinced that plaintiff’s construction is supported by intrinsic and extrinsic evidence, and that plaintiff’s construction adds clarity to the claims.

**D. Court’s Construction.**

“Data block” means “a single unit of data, which may range in size from individual bits through complete files or collection of multiple files.”

**ORDER**

For the reason above, the Court establishes the following definitions for the claim terms in dispute.

- The term “access profile” in Claims 1 and 14 of the ‘535 patent is defined as “comprising the read and write data that enables the controller to select a suitable compression algorithm that provides a desired balance between execution speed (rate of compression) and efficiency (compression ratio).”
- The term “throughput of a communication channel” in Claims 1, 9, and 12–14 of the ‘610 patent is defined as the “number of pending transmission requests over a communication channel.”
- The term “asymmetric compressor(s)” in Claims 12, 15, 16, and 24 of the ‘535 patent, “asymmetric data compression” in Claims 1 and 10 of the ‘535 patent, “asymmetric compression data algorithm/compression algorithms being asymmetric” in Claims 1 and 9 of the ‘610 patent, and “asymmetric” in Claims 6 and 16 of the ‘610 patent means “a compression algorithm in which the execution time for compression and decompression differ significantly.”

- The term “compressor” in Claims 1, 8, 10, 12, and 14–16 of the ‘535 patent means a “data compression encoder.”
- The term “compressing / compressed /compression” in Claims 1, 2, 6, 8–14, 16, and 18 of the ‘610 patent and Claims 1–2, 4-6, 8, 10–12, 14–17, 19, and 21–22 of the ‘535 patent means “[representing / represented / representation] of data with fewer bits.”
- The term “algorithm” in Claims 1, 6, 9, 12–14, and 16 of the ‘610 patent means “a set of rules.”
- The term “files” in Claims 3, 4, and 11 of the ‘535 patent requires no construction. The plain and ordinary meaning of the term can be determined by one of ordinary skill in the art from the word itself.
- The term “data block” in Claim 1, 2, 8–14, and 18 of the ‘610 patent and Claims 1, 2–6, 8–12, 14–17, 19, 21–22, and 24 of the ‘535 patent is defined as “a single unit of data, which may range in size from individual bits through complete files or collection of multiple files.”

DATED this day 11th day of January, 2019.

BY THE COURT:

A handwritten signature in black ink, appearing to read "Brooke Jackson", with a long, sweeping horizontal flourish extending to the right.

---

R. Brooke Jackson  
United States District Judge