

**UNITED STATES DISTRICT COURT
DISTRICT OF CONNECTICUT**

FLOODBREAK, LLC,
Plaintiff,

v.

ART METAL INDUSTRIES, LLC, et al.,
Defendants.

No. 3:18-cv-503 (SRU)

**RULING ON DEFENDANTS' MOTION FOR SUMMARY JUDGMENT OF NON-
INFRINGEMENT OR INVALIDITY**

FloodBreak, LLC (“FloodBreak”) filed the instant patent infringement suit against Art Metal Industries, LLC (“AMI”) and its principal owner, Kevin F. Biebel (collectively, “Defendants”). The complaint alleges that Defendants are directly infringing and inducing infringement of multiple claims of FloodBreak’s United States Patent No. 9,752,324 (“the ‘342 patent”), entitled “Flood Protection for Underground Air Vents,” under 35 U.S.C. § 271, et seq. It further alleges that Defendants’ infringement is willful.

Defendants have moved for summary judgment of non-infringement of all asserted patent claims, propounding the argument that the accused products do not contain the limitation “stops . . . not obstructing said passage,” which is recited in each of the claims. Mot. for Summ. J., Doc. No. 153, at 1. Specifically, Defendants argue that the plain and ordinary meaning of the “stops . . . not obstructing” limitation is that the stops do not protrude into or create any area loss within a passage. *Id.* at 7–9. It necessarily follows, Defendants claim, that the “plinth blocks” in AMI’s products—which FloodBreak has identified as reading on the claimed stops—do not infringe the limitation because they “protrude into and cause area loss within the passage created by the sidewalls” of the accused products. *Id.* at 6–7.

Defendants further assert that, even if I adopt FloodBreak’s construction of the “stops . . . not obstructing” limitation—which is that the component can protrude into and create area loss within the passage, as long as it does not block the movement of air—FloodBreak cannot carry its burden of proving infringement. *Id.* at 9–11. Lastly, they contend that, under FloodBreak’s construction, the asserted claims are indefinite and therefore invalid pursuant to 35 U.S.C. § 112. *Id.* at 11–16.

FloodBreak opposes the motion, principally on the following grounds: (1) the plain and ordinary meaning of the “stops . . . not obstructing” limitation is that the stops cannot block the movement of air; (2) the record raises triable issues on whether Defendants’ products infringe the “stops . . . not obstructing” limitation under such a construction; and (3) the limitation is not indefinite as a matter of law. *Opp. to Mot. for Summ. J., Doc. No 178, at 13–22.*

I agree with FloodBreak. As I explain below, I conclude that FloodBreak’s construction of the “stops . . . not obstructing” limitation should govern, and that a juror could reasonably find that AMI’s products infringe the limitation under such interpretation. I further conclude that Defendants have not sufficiently demonstrated that FloodBreak’s construction renders the asserted claims indefinite and that the limitation is not indefinite as a matter of law. I therefore **deny** Defendants’ motion for summary judgment of non-infringement or invalidity.

I. Standard of Review

A court shall grant summary judgment when the movant demonstrates that there is no genuine dispute with respect to any material fact and that the movant is entitled to judgment as a matter of law. Fed. R. Civ. P. 56(a); *see also Anderson v. Liberty Lobby, Inc.*, 477 U.S. 242, 256 (1986). When reviewing a summary judgment motion, a court must construe the facts of record in the light most favorable to the nonmoving party and must resolve all ambiguities and draw all

reasonable inferences against the moving party. *Anderson*, 477 U.S. at 255; *Matsushita Elec. Indus. Co. v. Zenith Radio Corp.*, 475 U.S. 574, 587 (1986); *Adickes v. S.H. Kress & Co.*, 398 U.S. 144, 158–59 (1970).

When a motion for summary judgment is properly supported by documentary and testimonial evidence, however, the nonmoving party may not rest upon the mere allegations or denials of the pleadings and instead must present sufficient probative evidence to establish a genuine issue of material fact. *Celotex Corp. v. Catrett*, 477 U.S. 317, 327 (1986); *Colon v. Coughlin*, 58 F.3d 865, 872 (2d Cir. 1995). To present a “genuine” issue of material fact, there must be contradictory evidence “such that a reasonable jury could return a verdict for the non-moving party.” *Anderson*, 477 U.S. at 248. “Only disputes over facts that might affect the outcome of the suit under the governing law will properly preclude the entry of summary judgment.” *Id.*

If the nonmoving party has failed to make a sufficient showing on an essential element of his case with respect to which he has the burden of proof at trial, then summary judgment is appropriate. *Celotex*, 477 U.S. at 322. In that instance, “there can be ‘no genuine issue as to any material fact,’ because a complete failure of proof concerning an essential element of the nonmoving party’s case necessarily renders all other facts immaterial.” *Id.* at 322–23; *accord Goenaga v. March of Dimes Birth Defects Found.*, 51 F.3d 14, 18 (2d Cir. 1995) (holding that a movant’s burden is satisfied if he can point to an absence of evidence to support an essential element of the nonmoving party’s claim).

II. Background

A. Statement of Facts¹

1. '342 Patent Specification²

The '342 patent is directed to a flood prevention apparatus that can be installed in a ventilation shaft, such as under a subway grating leading to an underground tunnel system like the New York City subway. Pl. Local Rule 56(a)2 Statement of Additional Facts, Doc. No. 179, at ¶ 1 (citing Harris Ex. A ('342 Patent), Doc. No. 147-1, at Abstract).

a. Patent Claims

The preamble to each of the independent patent claims³ states that the invention is an apparatus that “allow[s] ventilation” from an underground ventilation duct through a ventilation shaft to an atmospheric opening. Pl. Local Rule 56(a)2 Statement of Additional Facts, Doc. No. 179, at ¶ 8 (citing Harris Ex. A, Doc. No. 147-1, at cols. 14–18.). The preamble further provides that, “on threat of flooding,” the apparatus is “operable to prevent downward flood of surface water into the underground ventilation duct.” Harris Ex. A, Doc. No. 147-1, at cols. 14–18.

Each of the independent claims, and thus all of the asserted claims, include the following limitations:⁴ (a) “a support for arrangement in said shaft defining a passage between top and

¹ The facts are drawn primarily from the parties' Local Rule 56(a)1 and Local Rule 56(a)2 Statements of Fact. Unless otherwise indicated, the facts are not disputed.

² Under 35 U.S.C. § 112, “[t]he specification shall contain a written description of the invention, and of the manner and process of making and using it” and “shall conclude with one or more claims particularly pointing out and distinctly claiming the subject matter which the inventor or a joint inventor regards as the invention.” 35 U.S.C. § 112(a), (b).

³ “[T]he claims of a patent define the invention to which the patentee is entitled the right to exclude.” *Phillips v. AWH Corp.*, 415 F.3d 1303, 1312 (Fed. Cir. 2005). Claims are either independent or dependent. *Jeneric/Pentron, Inc. v. Dillon Co., Inc., Chemichl Inc., Chemichl AG.*, 171 F. Supp. 2d 49, 58 (D. Conn. 2001). “An independent claim does not refer to any other claim of the patent and is read separately to determine its scope.” *Id.* Meanwhile, a “dependent claim refers to at least one other claim in the patent, includes all of the limitations of the claim to which it refers, and specifies a further limitation on that claim.” *Id.*

⁴ Although the parties use the terms “element” and “limitation” interchangeably, I refer to the subcategories of the claim language as limitations throughout the opinion. As the Federal Circuit clarified, “[i]t is preferable to use the term ‘limitation’ when referring to claim language and the term ‘element’ when referring to the accused

bottom openings of the support for fluid communication of said ventilation duct up through said support to said atmospheric opening;” (b) “one or more stops within and connected to said support proximate said bottom opening and not obstructing said passage;” and (c) “one or more panels mounted in said support for rotation upwardly to an upright home position not obstructing said passage” Defs. Local Rule 56(a)1 Statement of Facts, Doc. No. 149, at ¶ 1; Harris Ex. A, Doc. No. 147-1, at cols. 14–18.

In addition, asserted dependent claim 10 requires that an apparatus include a beam “unobstructively horizontally spanning” across the passage. Pl. Local Rule 56(a)2 Statement of Additional Facts, Doc. No. 179, at ¶ 10; Harris Ex. A, Doc. No. 147-1, at 15:15–18).

b. Detailed Description of Embodiments

The ’342 patent specification discusses “exemplary embodiments” of the invention. According to the specification’s detailed description of the embodiments, when the apparatus is in a non-deployed state—that is, with at least one panel door in an upright home position—it allows ventilation as usual from the underground tunnel system up through the ventilation shaft, through a passage in the apparatus, and out to an atmospheric opening at the top of the apparatus. *See* Pl. Local Rule 56(a)2 Statement of Additional Facts, Doc. No. 179, at ¶ 2 (citing Doc. No. 147-1, at 3:30–52). On threat of flooding, at least one panel door can be deployed so that it rotates downwardly to a passage closing position, precluding surface waters from flooding the underground tunnel. *Id.* at ¶ 3 (citing Doc. No. 147-1, at 3:30–52).

The detailed description of the embodiments further instructs: “[i]n an exemplary embodiment, the support may comprise a hinge mount mounting member unobstructively

device.” *Lockheed Martin Corp. v. Space Sys./Loral, Inc.*, 324 F.3d 1308, 1315 n.1 (Fed. Cir. 2003) (citation omitted).

horizontally spanning across the support passage” Doc. No. 147-1, at 6:52–54. It elaborates, “[b]y unobstructively is meant that the hinge mounting member does not block movement of air through the passage.” *Id.* at 6:59–61.

The description then reads: “[i]n an exemplary embodiment[,] a beam unobstructively horizontally spans across the support passage and connects to opposed sides of the support proximate the top opening.” *Id.* at 6:62–65. It continues: “by unobstructively, is meant that the beam does not block movement of air through the passage.” *Id.* at 6:65–68.

c. Figures of an Exemplary Embodiment: Apparatus 100

The specification includes figures of exemplary embodiments, including the following views of one such embodiment, “Apparatus 100,” with shading added by FloodBreak.

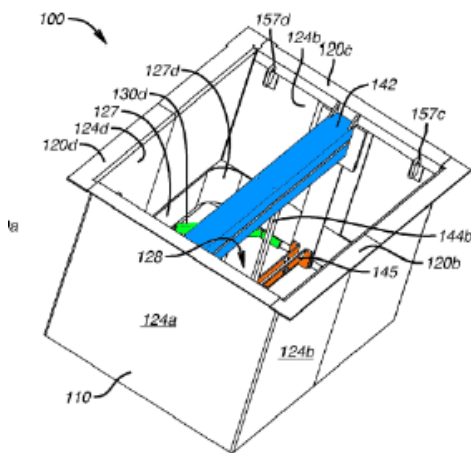

FIG. 17

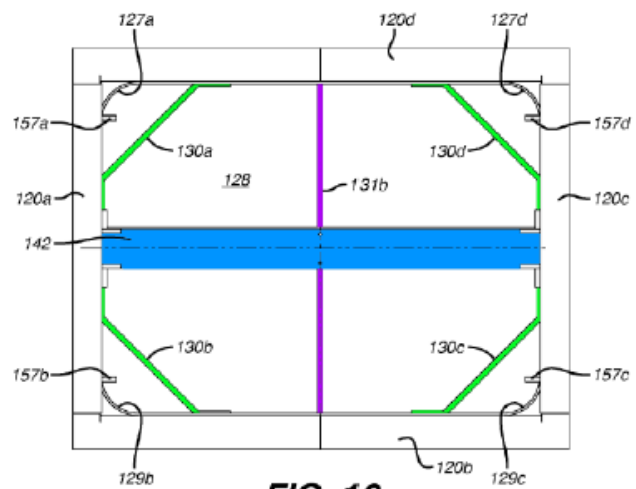

FIG. 19

Defs. Local Rule 56(a)1 Statement of Facts, Doc. No. 149, at ¶ 2; Pl. Local Rule 56(a)2 Statement of Additional Facts, Doc. No. 179, at ¶ 5.

The exemplary embodiment depicted above is described as follows:

Apparatus 100 comprises a four-sided box 110 inclusive of sidewalls 124 (124 a, 124 b, 124 c, 124 d) having at the upper extent of the sidewalls flanges 120 (120 a, 120 b, 120 c, 120 d) transverse to the sidewalls 124 for extension over a top of walls of a ventilation shaft for suspension of box 110 vertically in the shaft to define a passage 125 between top opening 126 and bottom opening 128 of box 110 for fluid communication of a ventilation duct up through box 110 to an atmospheric top opening 126. Stops 130 a, 130 b, 130 c and 130 d in the form of corner braces and 131 b (a stiffener support) are within and connected to sidewalls 124 proximate bottom opening 128 and do not obstruct passage 125.

Pl. Local Rule 56(a)2 Statement of Additional Facts, Doc. No. 179, at ¶ 4 (citing Harris Ex. A., Doc. No. 147-1, at 11:21–33).

Figures 17 and 19 exhibit stops (130a–130c, which are shaded green), a beam (142, shaded blue), a stiffener support (131b, shaded purple), and a hinge mount mounting member (145, shaded orange) in the passage. Pl. Local Rule 56(a)2 Statement of Additional Facts, Doc. No. 179, at ¶ 5 (citing Doc. No. 147-1, at 11:21–52; Figures 17, 19). The beam and hinge mount mounting member are again described as “unobstructively” spanning across the passage. Doc. No. 147-1, at 11:40–45.

2. FloodBreak’s Expert Reports

The accused AMI products, which are mechanical closure devices (“MCDs”), contain “plinth blocks” that evidently protrude into the passage created by the sidewalls of the MCD. Defs. Local Rule 56(a)1 Statement of Facts, Doc. No. 149, at ¶¶ 13, 19.

In a report on infringement authored by FloodBreak’s expert, Dr. Charles Reinholtz, there is a section entitled “one or more stops,” which examines the claim limitation at issue: “one or more stops . . . not obstructing said passage.” Ex. B, Doc. No. 147-2, at 38–40. In that section, Dr. Reinholtz writes:

Defendants’ MCDs satisfy this claim element. In particular, Defendants’ MCDs include plinth blocks, which correspond to the claimed “stops,” and are made of extruded aluminum and welded to the inside side walls of the support.

Id. at ¶ 77.

Also in that section, Dr. Reinholtz reproduces an AMI engineering drawing of a plinth block, which depicts a plinth block protruding inwardly, from 1.125 inches to 2 inches, toward the interior space of the MCD. Pl. Local Rule 56(a)2 Statement of Facts, Doc. No. 179, at ¶¶ 12–13 (citing Doc. No. 147-2, at ¶ 77). Dr. Reinholtz additionally cites to the deposition testimony of a project manager at T. Moriarty & Sons (“Moriarty”)—a general MTA contractor to whom AMI supplies MCDs—that the plinth blocks in AMI’s MCDs “stop[] the door from rotating.” *See* Defs. Local Rule 56(a)1 Statement of Facts, Doc. No. 149, at ¶ 16; Doc. No. 147-2, at ¶¶ 32, 77–78. Dr. Reinholtz further notes that “[t]he plinth blocks do not obstruct the claimed passage, as demonstrated, e.g., in the below picture,” citing to a picture of an AMI MCD. Doc. No. 147-2, at ¶ 79.

The section’s final paragraph reiterates that Defendants’ MCDs “satisfy this claim element.” *Id.* at ¶ 80. As support, Dr. Reinholtz cites to earlier paragraphs in the report that include technical drawings of the plinth blocks, and that describe the structure and operation of the MCDs. *Id.* Dr. Reinholtz concludes, “I have reviewed the drawings and descriptions of the [four main types of AMI MCDs] provided . . . to confirm that this element is met.” *Id.*

In other sections of his report, Dr. Reinholtz cites to (1) engineering reports, which allegedly confirm that, when AMI’s MCDs are in an “open position”—that is, with their panel doors in an upright state— the devices allow “substantial air ventilation through the shaft;” (2) the requirement in Section 10PJ of Contract No. E-31689—an MTA contract with Moriarty—that “when the doors of the MCD are in the open position air readily flows through to the space below;” and (3) Biebel’s testimony that “we take that Section called 10PJ in a contract, [and] we follow it by the letter.” Doc. No. 147-2, at ¶¶ 29, 30, 32, 64.

In Dr. Reinholtz's supplemental report, which he prepared based on his physical inspection of a representative AMI MCD, he reproduces a picture of the inspected MCD in further support of his conclusion that the plinth blocks do not obstruct the claimed passage. *See* Doc. No. 147-4, at ¶ 15.

3. *FloodBreak's Expert Testimony*

In his deposition, Dr. Reinholtz testified that the plinth blocks in the accused AMI MCDs “protrude[e] into the passage created by the sidewalls” and create “some loss of area in the passage.” Defs. Local Rule 56(a)1 Statement of Facts, Doc. No. 149, at ¶ 18 (citing Ex. I, Doc. No. 147-9, at 42:17–22; 43:10–12). In response to the question of how, then, he reached the conclusion that the plinth blocks do not obstruct the passage, Dr. Reinholtz explained: “I think a person of ordinary skill in the art would interpret obstructing the passage as minimizing the area that has to be removed to create the desired features. And so while they do take up some area, it is a small amount of area and there is still a clear – a clear opening for flow of air for ventilation.” Tr., Doc. No. 147-9, at 40:19–41:4. Dr. Reinholtz elaborated:

Not obstructing the passage means that there has to be an opening that the air flow can occur and not be mitigated significantly. There – there is some loss of area with the plinth block stops and with other components and the grading that is over the MCD. But keeping that to a small value to allow the free flow of air is the way I interpret not obstructing or unobstructively.

Id. at 43:7–16.

He further stated that, “[t]here is a goal of allowing ventilation, which has to do with not obstructing the passage.” *Id.* at 44:8–10. In response to the subsequent question of “[h]ow much of the passage would the stops need to obstruct before they fell outside of the scope of this claim,” Dr. Reinholtz noted:

I haven't been asked to give an opinion on an exact value, and I don't think that an exact value is necessary. The inspected device, the accused products, there is a relatively small amount of area taken by the plinth blocks. I haven't seen a case where half of it is taken and had to analyze that case, for example.

Id. at 44:11–23.

The following exchange then transpired:

HARRIS: So you are just not prepared to give an opinion one way or the other on – on how much of the passage would need to be obstructed to fall outside of the claim scope. Is that fair to say?

DR. REINHOLTZ: I don't think it is necessary as a person of ordinary skill in the art to provide a precise number, a precise percentage that would be removed.

HARRIS: You would just know it when you see it?

DR. REINHOLTZ: No, I wouldn't say that. There are calculations that can be performed relating to air flow and area loss. This is clearly a small fraction of the area that is lost.

Id. at 44:24–45:15.

When asked to clarify his definition of area loss, he explained, “the plinth blocks themselves have a vertical dimension and the area loss is different at different cross-sections even along the plinth block. So I think it is a term that relates to the general opening defined by the side walls, but other features as well.” *Id.* at 45:17–46:3. He also stated:

So area that is lost could be considered in multiple ways, but a simple way to think about it, and a common way, is to look at cross-sections. So cross-sections that are horizontal relative to the horizon. And different cross-sections of the devices have different components or features that are necessary for operation that reduce some small amount of area.

Id. at 46:10–17.

In addition, Dr. Reinholtz testified that he “reviewed calculations of area loss” relating to the accused MCDs and that, although he did not necessarily rely on those calculations, he believed they reinforced his understanding of area loss. *Id.* at 46:24–48:5. According to his

testimony, he did not perform his “own calculations to look at the plinth block cross-section to see what area is lost and what area is remaining there.” *Id.* at 46:24–47:4.

4. *Defendants’ Expert Reports*

Defendants’ expert, David Smith, prepared and served an expert report on invalidity on August 7, 2019 and on non-infringement on September 6, 2019. *See* Autuoro Ex. A, Doc. No. 180-1 (invalidity report); Autuoro Ex. F, Doc. No. 180-6 (non-infringement report).

In his invalidity report, Smith prefaced his analysis of the asserted claims with the following statement:

In the following analysis, Claims 1, 4-5, 8, 10, 14, and 20-24 of the ‘342 Patent are described as they would be understood by a person of ordinary skill in the art of designing devices that block flooding water from entering underground ventilation passages at the time of the invention of the ‘342 Patent.

Doc. No. 180-1, at ¶ 23.

As explained in the report, Smith concluded that the asserted claims were anticipated by or obvious in light of prior art, and were therefore invalid. *Id.* at 102–03. He opined that the “stops . . . not obstructing” limitation was satisfied by prior art references, such as a flood control device patented to Stephen Petrillo. Pl. Local Rule 56(a)2 Statement of Additional Facts, Doc. No. 179, at ¶ 28 (citing Doc. No. 180-1, at 76).

The invalidity report does not state that the “stops . . . not obstructing” limitation is invalid for indefiniteness under 35 U.S.C. § 112. Pl. Local Rule 56(a)2 Statement of Additional Facts, Doc. No. 179, at ¶ 26; *see also* Ex. A, Doc. No. 180-1. The non-infringement report also does not refute Dr. Reinholtz’s opinion that the accused MCDs satisfy the “one or more stops . . . not obstructing the passage” limitation, or otherwise state that the limitation was not met by the

accused MCDs. Pl. Local Rule 56(a)2 Statement of Additional Facts, Doc. No. 179, at ¶ 25; *see also* Dec. Ex. F, Doc. No. 180-6.

B. Procedural History

FloodBreak filed the instant suit on March 26, 2018. *See* Compl., Doc. No. 1. As asserted in its complaint, FloodBreak alleges that Defendants infringed, and continue to infringe, claims 1, 4–5, 8, 10, 14, and 20–24 of the ‘342 patent by making, using, offering to sell, and selling MCDs covered by the ‘342 patent. *Id.* at ¶¶ 21–22. The complaint specifically alleges that Biebel and AMI are both directly infringing and inducing infringement of the ‘342 patent, and that their infringement is willful. *Id.* at ¶¶ 21–25. FloodBreak seeks an order permanently enjoining AMI’s allegedly-infringing activities as well as monetary damages. *Id.* at ¶ 27.

Defendants answered the complaint on May 11, 2018. Ans., Doc. No. 23.

During claim construction, the parties presented arguments on the construction of the term “stops,” as used in the independent claims. In my claim construction ruling dated July 2019, I reasoned that, because the claims and the specification did not “contradict the ordinary and customary meaning of the term,” the term “stops” did not require construction. Order, Doc. No. 94, at 7. I noted that the detailed description of embodiments provided: “the concept of the invention is not limited to this disposition. Stops for stopping panel lowering may be positions to stop the downward travel above horizontal and still close a ventilation passage.” *Id.* at 6. I also observed that the specification “shows that the stops bring a panel to a halt.” *Id.*

Defendants filed the instant motion for summary judgment on February 12, 2020 following the close of discovery. Doc. No. 147. FloodBreak opposed the motion on March 13,

2020, doc. no. 178, and Defendants replied on March 27, 2020, doc. no. 188. Oral argument was held on June 11, 2020 on all pending motions.⁵

III. Discussion

A. I Will Not Strike the Non-Infringement and Invalidity Arguments Because There is No Evidence That Any Belated Disclosure Was Prejudicial or A Product of Bad Faith.

FloodBreak first contends that the arguments advanced by Defendants in support of their motion should be stricken under Federal Rules of Civil Procedure 26 and 37 because they were not disclosed until Defendants served their second supplemental contentions on February 5, 2020, which was one week before the dispositive motions deadline and after Defendants served their expert reports and first supplemental contentions. Opp. to Mot. for Summ. J., Doc. No. 178, at 13–14. I disagree.

The Second Circuit has held that district courts may entertain defenses that are first raised in a motion for summary judgment by construing the motion as one to amend the answer. *Monahan v. New York City Dep't of Corr.*, 214 F.3d 275, 283 (2d Cir. 2000). Under Federal Rule of Civil Procedure 15, leave to amend the pleadings shall be “freely give[n] when justice so requires.” Fed. R. Civ. Proc. 15(a)(2). Accordingly, “absent evidence of undue delay, bad faith or dilatory motive on the part of the movant, undue prejudice to the opposing party, or futility, Rule 15’s mandate must be obeyed.” *Monahan*, 214 F.3d at 283.

As an initial matter, Defendants’ arguments do not appear new at this juncture.

Defendants’ answer asserted that (1) the ‘342 patent is invalid as an affirmative defense, and (2)

⁵ Defendants have filed four other motions: (1) a motion for summary judgment based on a patent license (doc. no. 60); (2) a motion for summary judgment of no direct or indirect infringement by Biebel and no willful infringement by Defendants (doc. no. 142); (3) a motion to exclude testimony of FloodBreak’s damages expert (doc. no. 135); and (4) a motion for summary judgment of no lost profits damages (doc. no. 130). I address those in separate opinions.

AMI's products do not directly infringe the '342 patent as a counterclaim seeking a declaratory judgment. *See* Answer, Doc. No. 23, at 5–6, 12. The arguments that Defendants advance in the instant motion—that AMI's products do not infringe the “stops. . . not obstructing” limitation and, in the alternative, that such limitation is indefinite—seem to fall squarely within the confines of the assertions raised in the answer.

Even if the defenses are new, I will allow the claims to proceed under Federal Rule of Civil Procedure 15(a)(2). FloodBreak does not claim that Defendants' delayed notice was in bad faith and, in my view, FloodBreak's argument that it was prejudicial is unavailing.

In assessing whether prejudice exists, courts “generally consider whether the assertion of the new claim or defense would ‘(i) require the opponent to expend significant additional resources to conduct discovery and prepare for trial; (ii) significantly delay the resolution of the dispute; or (iii) prevent the plaintiff from bringing a timely action in another jurisdiction.’” *Monahan*, 214 F.3d at 284 (internal citations omitted). FloodBreak invokes only the first prong; it asserts that the delayed notice was prejudicial because it lost its opportunity to explore the arguments through discovery. *Opp. to Mot. for Summ. J.*, Doc. No. 178, at 14.

FloodBreak, however, does not explain what additional fact or expert discovery would have been necessary to refute Defendants' arguments. Moreover, Defendants do not rely on expert testimony in support of their arguments, doc. no. 186, at 10, and FloodBreak had a considerable amount of time to conduct discovery. The original discovery deadline was September 25, 2018 and was extended by nearly two months to November 18, 2019. *See* Doc. No. 105. Tellingly, FloodBreak did not seek to re-open discovery pursuant to Federal Rule of Civil Procedure 16, which provides that a schedule may be modified “for good cause and with the judge's consent.” Fed. R. Civ. P. 16(b)(4).

I think there is a closer question regarding whether good cause existed for Defendants' delay in raising the defenses. Defendants purport to justify the delay by contending that, because FloodBreak did not disclose Dr. Reinholtz's construction of the "stops . . . not obstructing" limitation until his deposition in December 2019, Defendants' expert, Smith, "could not have known of, or applied, that construction as part of the invalidity opinions that he completed and served in August 2019." Reply, Doc. No. 186, at 10. Even if that were true, the argument does not address why Defendants did not previously mount the defense that the accused MCDs do not recite the "stops . . . not obstructing" limitation.

Regardless, because of the absence of bad faith and prejudice, and in light of Rule 15's objective "to provide maximum opportunity for each claim to be decided on its merits rather than on procedural technicalities," *Slayton v. AM. Express Co.*, 460 F.3d 215, 288 (2d Cir. 2006) (internal quotations and citations omitted), I will decide the claims on their merits.

B. Considering the Intrinsic Evidence, I Conclude That "Stops . . . Not Obstructing Said Passage" Means That the Stops Cannot Block the Movement of Air Through the Passage.

Turning to Defendants' argument that AMI's MCDs do not satisfy the "one or more stops . . . not obstructing said passage" limitation, it is well-settled that determining infringement involves a two-part inquiry. First, the relevant claim must be construed. *Akzo Nobel Coatings, Inc. v. Dow Chem. Co.*, 811 F.3d 1334, 1339 (Fed. Cir. 2016). Second, the properly construed claim must be compared to the accused product. *Id.* Accordingly, I address first the issue of how to construe "one or more stops . . . not obstructing said passage"—the only limitation in dispute.⁶

⁶ I note that the parties should have raised this claim construction issue at the *Markman* hearing rather than a year later in their summary judgment briefs. Although counsel had every opportunity to do so, they did not ask for a construction of, and therefore I did not construe, the term "not obstructing" at the hearing. That would have been the more appropriate forum for me to resolve this question.

As a general matter, the claims of a patent define the invention that a patentee is granted the right to exclude others from making or using, and the specification functions as a basic presentation teaching that invention. *See Innova/Pure Water Inc. v. Safari Water Filtration Systems, Inc.*, 381 F.3d 1111, 1115 (Fed. Cir. 2004); *Oak Technology Inc. v. International Trade Commission*, 248 F.3d 1316, 1328–29 (Fed. Cir. 2001). Courts construe claims in order to resolve disputes about claim terms and assign an unambiguous meaning to the claim. *See Liquid Dynamics Corp. v. Vaughan Co.*, 355 F.3d 1361, 1367 (Fed. Cir. 2004).

“The inquiry into how a person of ordinary skill in the art understands a claim term provides an objective baseline from which to begin claim interpretation.” *Phillips v. AWH Corp.*, 415 F.3d 1303, 1313 (Fed. Cir. 2005). Courts first look to the language in the claims themselves, both asserted and nonasserted, to determine the meaning of a particular claim term. *Vitronics Corp. v. Conceptoronic, Inc.*, 90 F.3d 1576, 1582 (Fed. Cir. 1996); *Phillips*, 415 F.3d at 1314. Because the claims define an invention, limitations from the specification should not be read into those claims. *See Comark Communications, Inc. v. Harris Corp.*, 156 F.3d 1182, 1186–87 (Fed. Cir. 1998). Nonetheless, claims “must be read in view of the specification, of which they are a part.” *Phillips*, 415 F.3d at 1315 (citing *Markman v. Westview Instruments, Inc.*, 52 F.3d 967, 979 (Fed. Cir.) (en banc)), *aff’d*, 517 U.S. 370 (1996)). The specification is “highly relevant to the claim construction analysis . . . [and is] the single best guide to the meaning of a disputed term.” *Vitronics*, 90 F.3d at 1582. Moreover, where the plain and ordinary meaning of a term is clear, no additional construction is necessary. *See Summit 6, LLC v. Samsung Elecs. Co.*, 802 F.3d 1283, 1291 (Fed. Cir. 2015).

Here, Defendants maintain that the plain and ordinary meaning of the “stops . . . not obstructing said passage” limitation is that the stops cannot create any area loss within or

protrude into the passage. *See* Mot. for Summ. J., Doc. No. 153, at 7–9. FloodBreak proffers a different interpretation; it argues that the plain and ordinary meaning of the limitation is that “stops cannot block movement of air through the passage.” Opp. to Mot. for Summ. J., Doc. No. 178, at 2. According to FloodBreak, a component can therefore protrude into the passage under the plain and ordinary meaning. *Id.* at 4.

Considering the patent in its entirety, it is without question that FloodBreak’s construction is the correct one. Defendants do not point to any part of the ‘342 patent that corroborates their construction, nor could I locate any such support. On the contrary, the patent specification conflicts with their interpretation. For example, the specification depicts figures of exemplary embodiments, including Figures 17 and 19 as depicted above. That embodiment has multiple components, including stops, which are described as “not obstruct[ing]” the passage. Defs. Local Rule 56(a)1 Statement of Facts, Doc. No. 149, at ¶ 2; Pl. Local Rule 56(a)2 Statement of Additional Facts, Doc. No. 179, at ¶¶ 5, 6.

As is evident from the depictions, the stops protrude into the passage and take up space. Accordingly, because claims must be read in view of the specification, Defendants’ argument that the plain and ordinary meaning of the “stops . . . not obstructing” limitation precludes stops from causing area loss or protruding into the passage cannot stand. *Accent Packaging, Inc. v. Leggett & Platt, Inc.*, 707 F.3d 1318, 1326 (Fed. Cir. 2013) (“[A] claim interpretation that excludes a preferred embodiment from the scope of the claim is rarely, if ever, correct.”) (quoting *On-Line Techs., Inc. v. Bodenseewerk Perkin-Elmer GmbH*, 386 F.3d 1133, 1138 (Fed. Cir. 2004)). Such a construction would add a limitation that is nowhere apparent in the patent specification, in contravention of explicit guidance from the Federal Circuit. *Rambus Inc. v.*

Infineon Techs. Ag, 318 F.3d 1081, 1087 (Fed. Cir. 2003) (“This court has repeatedly and clearly held that it will not read unstated limitations into claim language.”) (internal citations omitted).

Defendants’ construction is also inconsistent with the specification’s descriptions of the embodiment’s beam and “hinge mount mounting member,” as depicted above. Both the beam and hinge mount mounting member are described as “unobstructively” spanning across the passage. Doc. No. 147-1, at 11:40–45. As was the case with the stops, the beam and hinge mount mounting member evidently protrude into, and cause area loss within, the passage.

FloodBreak’s proposed construction, in contrast, finds support in multiple parts of the patent specification. For instance, the detailed description of the embodiments defines “unobstructively” as “not block[ing] movement of air though the passage.” Doc. No. 147-1, at 6:59–61 (referencing a hinge mount mounting member); *id.* at 6:65–68 (referencing a beam). Although Defendants argue that the definition of “unobstructively” has no bearing here because (a) “unobstructively” is used to describe features other than a stop, and (b) “unobstructively” is different than the phrase “not obstructing,” neither argument has merit.⁷ “Unobstructively” and “not obstructing” both pertain to the same action—to obstruct—and as the Federal Circuit has emphasized, the entirety of the specification is instructive in claim construction. *See Phillips*, 415 F.3d at 1314–15.

The preamble to the independent claims, as well as other claim limitations, shed further light on the meaning of “stops . . . not obstructing.” The preamble to each independent claim states that the invention is an apparatus that “allow[s] ventilation” from an underground

⁷ Defendants cite to *Bancorp Servs., L.L.C. v. Hartford Life Ins. Co.*, 359 F.3d 1367 (Fed. Cir. 2004), for the proposition that different terms in a patent are presumed to have different meanings. That reliance is misplaced. There, the court stated that the use of different terms “*in close proximity in the same claim* gives rise to an inference that a different meaning should be assigned to each.” *Id.* at 1373 (emphasis added). Here, “unobstructively” and “not obstructing” are not used in close proximity in the same claim. Moreover, the court ultimately concluded that the presumption could be overcome, and that there was “substantial support” for interpreting the patent terms “stable value protected investment” and “surrender value protected investment” as synonymous. *Id.* at 1372–74.

ventilation duct through a ventilation shaft to an atmospheric opening. Pl. Local Rule 56(a)2 Statement of Additional Facts, Doc. No. 179, at ¶ 8. Moreover, each independent claim recites “a support for arrangement in said shaft defining a passage between top and bottom openings of the support for *fluid communication* of said ventilation duct up through said support to said atmospheric opening.” Doc. No. 147-1, at cols. 14–18 (emphasis added). The foregoing guidance indicates that a fundamental purpose of the invention is to allow ventilation when not in operation, and thus lends support to FloodBreak’s construction. *Vitronics Corp.*, 90 F.3d at 1582 (“[W]e look to the words of the claims themselves, both asserted and nonasserted, to define the scope of the patented invention.”).

Because the intrinsic evidence resolves the question of how to construe the “stops . . . not obstructing” limitation, I need not rely on extrinsic sources. *Id.* at 1583 (“In most situations, an analysis of the intrinsic evidence alone will resolve any ambiguity in a disputed claim term. In such circumstances, it is improper to rely on extrinsic evidence.”). I note, however, that the expert testimony is not at odds with FloodBreak’s interpretation. Significantly, Dr. Reinholtz testified at his deposition that “[n]ot obstructing the passage means that there has to be an opening that the air flow can occur.” Tr., Doc. No. 147-9, at 43:7–16.

For the foregoing reasons, I conclude that, as a matter of law, a person of ordinary skill in the art would construe the claim limitation “stops . . . not obstructing said passage” to mean stops that do not block the movement of air through the passage.

C. Applying FloodBreak’s Construction, A Reasonable Juror Could Conclude that AMI’s MCDs Infringe the “Stops . . . Not Obstructing” Limitation.

Defendants next argue that, even if I adopt FloodBreak’s construction, FloodBreak has not carried its burden of proving that the accused MCDs satisfy the “stops . . . not obstructing” limitation. Mot. for Summ. J., Doc. No. 153, at 9–11. According to Defendants, FloodBreak

therefore has not established that the accused MCDs infringe the '342 patent. *Id.* I am not persuaded.

FloodBreak bears the burden of proving infringement. *Medtronic, Inc. v. Mirowski Family Ventures, LLC*, 571 U.S. 191, 198–99 (2014). “Infringement, whether literal or under the doctrine of equivalents, is a question of fact.”⁸ *Akzo Nobel Coatings, Inc. v. Dow Chem. Co.*, 811 F.3d 1334, 1339 (Fed. Cir. 2016). Accordingly, “it is amenable to summary judgment when no reasonable factfinder could find that the accused product contains every claim limitation or its equivalent.” *Id.*

“Literal infringement exists when every limitation recited in the claim is found in the accused device.” *Id.* at 1341. “If even one limitation is missing or not met as claimed, there is no literal infringement.” *Brigham & Women's Hosp., Inc. v. Perrigo Co.*, 761 F. App'x 995, 1003 (Fed. Cir. 2019) (citation omitted). “The patentee has the burden of proving literal infringement by a preponderance of the evidence.” *Id.*

To establish infringement, FloodBreak relies on the report and testimony of its expert, Dr. Reinholtz. As articulated in his report, Dr. Reinholtz concluded that: (1) the “plinth blocks” in AMI’s MCDs correspond to the claimed stops; (2) the plinth blocks do not obstruct the claimed passage; and (3) AMI’s MCDs ultimately satisfy the claim limitation “one or more stops . . . not

⁸ FloodBreak seems to be pursuing a literal infringement claim, rather than a claim under the doctrine of equivalents. Under the doctrine of equivalents, “a product or process that does not literally infringe upon the express terms of a patent claim may nonetheless be found to infringe if there is ‘equivalence’ between the elements of the accused product or process and the claimed elements of the patented invention.” *Warner-Jenkinson Co. v. Hilton Davis Chem. Co.*, 520 U.S. 17, 21 (1997) (citation omitted). The test for the doctrine of equivalents is “whether the accused device performs substantially the same function in substantially the same way to obtain substantially the same result as the claim limitation.” *Virnetx, Inc. v. Cisco Sys., Inc.*, 767 F.3d 1308, 1322 (Fed. Cir. 2014).

Because I conclude that FloodBreak has sufficiently established that a reasonable jury could find literal infringement, I need not address the doctrine of equivalents. *QXMedical, LLC v. Vascular Sols., LLC*, 408 F. Supp. 3d 996, 1009 (D. Minn. 2019) (“If the jury finds literal infringement, then the jury will not be asked to determine whether the Boosting Catheter infringes under the doctrine of equivalents.”).

obstructing said passage.” Doc. No. 147-2, at ¶¶ 77–80. Dr. Reinholtz also elaborated in his deposition that there is a “clear opening for flow of air for ventilation” in AMI’s MCDs. Tr., Doc. No. 147-9, at 41:1–41:4.

Defendants claim that Dr. Reinholtz’s analysis falls short because Dr. Reinholtz did not rely on any calculations to determine (a) how much AMI’s plinth blocks affect the air flow in the passage or (b) how much area is lost in the passage because of the plinth blocks. Mot. for Summ. J., Doc. No. 153, at 10; Reply, Doc. No. 186, at 9. They argue that, because FloodBreak has not adduced expert testimony on the actual amount of air flow mitigation or area loss in the accused devices, FloodBreak cannot meet its burden. Reply, Doc. No. 186, at 9.

Those arguments are unavailing. Defendants do not explain why those calculations are relevant to the question of whether AMI’s plinth blocks “block” the flow of air. Moreover, the record amply supports the conclusion that the accused plinth blocks do not block air ventilation through the passage and thus satisfy the limitation at issue. First, Dr. Reinholtz’s report reproduces a picture of an AMI MCD, which shows the plinth blocks running along the base of the walls and leaving a clear opening for the movement of air through the passage. Doc. No. 147-2, at ¶ 79. Second, the supplemental expert report reproduces a picture of a representative AMI MCD that Dr. Reinholtz inspected, which likewise shows the plinth blocks leaving a clear opening for air ventilation through the passage. *See* Doc. No. 147-4, at ¶¶ 4, 15.

Other portions of Dr. Reinholtz’s report further support the conclusion that the plinth blocks satisfy the “stops . . . not obstructing” limitation. The report discusses (1) engineering reports, which “confirm[ed] that when [AMI’s] MCDs are in an ‘open’ position . . . the MCDs allow substantial air ventilation through the shaft;” (2) the requirement in Section 10PJ of Contract No. E-31689 that “when the doors of the MCD are in the open position air readily flows

through to the space below;” and (3) Biebel’s testimony that “we take that Section called 10PJ in a contract, [and] we follow it by the letter.” Pl. Local Rule 56(a)2 Statement of Facts, Doc. No. 179, at ¶ 17; *see also* Doc. No. 147-2, at ¶¶ 29, 64.

In sum, the record offers far more than “broad conclusory statements” that the plinth blocks are not obstructing the passage—that is, that the plinth blocks are not blocking the movement of air through the passage. *Jeneric/Pentron, Inc. v. Dillon Co., Inc., Chemichl Inc., Chemichl AG.*, 171 F. Supp. 2d 49, 55 (D. Conn. 2001). The corroborating evidence includes: (1) the photographs of the plinth blocks; (2) engineering reports; (3) MTA contract requirements relating to ventilation; (4) the deposition testimony of AMI that they complied with such requirements; and (5) the deposition testimony of Dr. Reinholtz. Considering the facts in the light most favorable to the non-moving party, FloodBreak has sufficiently established that there are questions that should be presented to a jury.

Because a reasonable factfinder could find by a preponderance of the evidence that the “stops . . . not obstructing” limitation—the only limitation in dispute—is present in AMI’s MCDs, I conclude that FloodBreak has carried its burden of proving infringement. *Brigham*, 761 F. App’x at 1003. I therefore **deny** summary judgment on the non-infringement defense.

D. The “Stops . . . Not Obstructing” Limitation is Not Invalid for Indefiniteness Pursuant to 35 U.S.C. § 112 Under FloodBreak’s Construction as a Matter of Law.

Defendants further argue that, under FloodBreak’s construction of the “stops . . . not obstructing” limitation, the asserted claims are invalid pursuant to 35 U.S.C. § 112 because they are indefinite as a matter of law. Mot. for Summ. J., Doc. No. 153, at 11–16. I disagree.

“Because claims delineate the patentee’s right to exclude, the patent statute requires that the scope of the claims be sufficiently definite to inform the public of the bounds of the protected invention, *i.e.*, what subject matter is covered by the exclusive rights of the patent.” *Halliburton*

Energy Servs., Inc. v. M-I LLC, 514 F. 3d 1244, 1249 (Fed. Cir. 2008). Section 112(b) sets forth the definiteness requirement, mandating that the specification of a patent “conclude with one or more claims particularly pointing out and distinctly claiming the subject matter which the inventor or a joint inventor regards as the invention.” *Tinnus Enterprises, LLC v. Telebrands Corp.*, 733 F. App’x 1011, 1016 (Fed. Cir. 2018) (citing 35 U.S.C. § 112(b)).

In *Nautilus*, the Supreme Court articulated the test for determining whether a patent satisfies section 112(b)’s definiteness requirement: whether its claims, “viewed in light of the specification and prosecution history, inform those skilled in the art about the scope of the invention with reasonable certainty.” *Tinnus Enterprises, LLC*, 733 F. App’x at 1017 (citing *Nautilus, Inc. v. Biosig Instruments, Inc.*, 572 U.S. 898, 901 (2014)). “As long as claim terms satisfy this test, relative terms and words of degree do not render patent claims invalid.” *One-E-Way, Inc. v. Int’l Trade Comm’n*, 859 F.3d 1059, 1063 (Fed. Cir. 2017).

Accordingly, to comply with the definiteness requirement, “a patentee need not define his invention with mathematical precision.” *Sonix Tech. Co. v. Publications Int’l, Ltd.*, 844 F.3d 1370, 1377 (Fed. Cir. 2017) (citations omitted). Indeed, “absolute precision is unattainable,” and “[t]he certainty which the law requires in patents is not greater than is reasonable, having regard to their subject-matter.” *Nautilus, Inc.*, 572 U.S. at 910 (citations omitted). At the same time, “[t]he claims, when read in light of the specification and the prosecution history, must provide objective boundaries for those of skill in the art.” *Interval Licensing LLC v. AOL, Inc.*, 766 F.3d 1364, 1371 (Fed. Cir. 2014).

Because a patent is presumed to be valid, the burden is on the challenger to prove that the specification is indefinite by clear and convincing evidence. *Intel Corp. v. VIA Techs., Inc.*, 319 F.3d 1357, 1366 (Fed. Cir. 2003); *Enzo Biochem, Inc. v. Applera Corp.*, 599 F.3d 1325, 1331

(Fed. Cir. 2010). “Indefiniteness is a legal question with underlying factual determinations.” *Tinnus Enterprises, LLC*, 733 F. App’x at 1016.

In the case at bar, Defendants argue that the “stops . . . not obstructing” limitation fails for indefiniteness under FloodBreak’s construction because the specification does not provide “objective boundaries” for those skilled in the art. As support, Defendants aver that (1) the specification does not define “not obstructing;” and (2) “the claims, specification, and prosecution history do not otherwise connect the claim term ‘one or more stops . . . not obstructing said passage’ to any concept of air flow through the passage.” Mot. for Summ. J., Doc. No. 153, at 13–14; Reply, Doc. No. 186, at 5–6.

The assertion of indefiniteness simply fails. As I discussed above, the specification includes figures of an exemplary embodiment, which depict stops placed in a passage and which describe the stops as “not obstruct[ing]” the passage. Defs. Local Rule 56(a)1 Statement of Facts, Doc. No. 149, at ¶ 2; Pl. Local Rule 56(a)2 Statement of Additional Facts, Doc. No. 179, at ¶¶ 5, 6. The embodiment also reflects a “beam” and “hinge mount mounting member,” and those components are similarly described as “unobstructively” spanning across the passage. Doc. No. 147-1, at 11:40–45. The specification, in turn, defines “unobstructively” as “not block[ing] movement of air through the passage.” *Id.* at 6:59–68.

Moreover, as noted, the claims establish that a key purpose of the invention is to permit ventilation when not in operation. The preamble to each asserted independent claim, for instance, states that the invention is an apparatus that “allow[s] ventilation” from an underground ventilation duct through a ventilation shaft to an atmospheric opening. Pl. Local Rule 56(a)2 Statement of Additional Facts, Doc. No. 179, at ¶ 8. Accordingly, Defendants’ arguments are without merit.

Defendants additionally argue that the limitation is invalid because the specification does not offer any detail on how much a component may impact airflow before falling outside the scope of the claim. Mot. for Summ. J., Doc. No. 153, at 13–14; Reply, Doc. No. 186, at 5–6. But the specification does not need to provide precise numbers regarding how much a component may impact a passage’s ventilation, because this mechanical patent covers MCDs of potentially variable dimensions with a range of potential air flows. Unlike an invention based on mathematical or molecular formula, for example, no one measure of air flow restriction will apply to every possible iteration of the ‘342 patent. Skilled artisans would not be prevented from practicing the invention by the claimed indefiniteness, because they would recognize that the limitation does not employ relative terms or words of degree: a stop either blocks air ventilation through the passage or it does not.

Defendants’ final argument is equally unavailing. Defendants assert that Dr. Reinholtz testified that “there are multiple ways to view area that is lost in the passage, multiple ways to calculate air flow, and multiple physical points within the passage at which such calculations might be appropriate.” Mot. for Summ. J., Doc. No. 153, at 14. They contend that summary judgment on the invalidity defense is therefore warranted because the patent fails to “provide any method for calculating whether any particular amount of area lost, or reduction in air flow caused by, a particular ‘stop’ would (or would not) affect whether that ‘stop’ falls within the scope of the claim term.” *Id.* at 12–14; Reply, Doc. No. 186, at 5–6.

Defendants mischaracterize Dr. Reinholtz’s testimony. In his deposition, he testified that (1) “[t]here are calculations that can be performed relating to air flow and area loss;” (2) “*area that is lost* could be considered in multiple ways;” and (3) “*the area loss* is different at different cross-sections even along the plinth block.” Doc. No. 147-9, at 45:12–14; 45:25–46:1; 46:10–11

(emphasis added). Although area loss may impact air flow, the two concepts are different, and that testimony does not establish that there are multiple ways to calculate *air flow* that could yield varying results. Such testimony, then, does not inform the question at hand—namely, whether construing the “stops . . . not obstructing” limitation as stops that do not block the movement of air through a passage renders the limitation indefinite.

Accordingly, I conclude that Defendants have failed to adequately establish that there are different ways of measuring air flow and, therefore, that measuring air flow using one method could cause a device to fall within the scope of the claim limitation while measuring air flow using a different method could cause that same device to fall outside of the scope. Defendants have thus failed to carry their burden of showing that a skilled artisan would have trouble understanding the scope of the limitation without knowing the precise method for calculating air flow. In other words, Defendants have not sufficiently established that knowing the method used to measure for air flow is critical to understanding the limitation.

Those facts distinguish the instant case from the three Federal Circuit cases on which Defendants rely: *The Dow Chem. Co. v. NOVA Chems. Corp. (Can.)*; *Liberty Ammunition v. United States*; and *Teva Pharms. USA, Inc. v. Sandoz, Inc.* In *Dow Chem*, the independent claims of the patents at issue required a “slope of strain hardening coefficient greater than or equal to 1.3.” *Dow Chem. Co. v. Nova Chemicals Corp. (Canada)*, 803 F.3d 620, 624–25 (Fed. Cir. 2015). After a jury found that the asserted claims had been infringed and were not invalid, the infringer argued on appeal that the patents were indefinite under the *Nautilus* standard because they failed to teach a person having ordinary skill in the art where and how to measure the “slope of strain hardening,” which is needed to calculate the strain hardening coefficient. *Id.* at 623–25, 633. The Federal Circuit agreed. In holding that the claims were invalid as

indefinite, the court emphasized that there were multiple methods to calculate the slope of strain hardening and that knowing the precise method of measurement was important. *Id.* at 633–35.

It specifically explained that each of those methods could produce different results—i.e., a different slope—and thus could impact whether or not a product infringes the claims. *Id.* That is not the case here.

Liberty Ammunition is likewise inapposite. There, the patent at issue described the design of the invention, a type of bullet, as “significantly reduc[ing] the area of contact of the projectile body with the rifling or interior surface of the barrel of the firearm.” *Liberty Ammunition, Inc. v. United States*, 835 F.3d 1388, 1392 (Fed. Cir. 2016). The district court construed the claim term “reduced area of contact” to mean “the area of contact between the interface and the rifling of the firearm is less than that of a traditional jacketed lead bullet of calibers .17 through .50 BMG.” *Id.* at 1394. Applying that construction, the parties’ experts examined twenty-six different projectiles as baselines, and the patentee’s expert testified that the accused projectiles had a reduced area of contact as compared to several, but not all, of the tested baselines. *Id.* at 1397–98. The district court concluded that the “mixed results [were] sufficient to show that the accused projectiles satisfy the ‘reduced area of contact’ limitation.” *Id.* at 1398.

The defendant appealed the trial court’s claim construction, and the Federal Circuit held that the construction was improper. *Id.* at 1397. The court reasoned that the claim would be indefinite under the district court’s construction, explaining that “a term of degree cannot be definite when construed in a manner that lends itself to this sort of scattershot infringement analysis.” *Id.* (internal citations and quotation marks omitted). In this case, by contrast, “not obstructing” is not a term of degree, and Defendants have not introduced any “mixed results”

that would compel me to conclude that the measure for air flow that the limitation covers is significant.

Finally, in *Teva Pharmaceuticals*, the Federal Circuit held that a claim term—“molecular weight”—was indefinite. The parties agreed that “molecular weight” could refer to three different measures— M_p , M_w , or M_n —each of which “is calculated in a different way and would typically yield a different result for a given polymer sample.” *Teva Pharm. USA, Inc. v. Sandoz, Inc.*, 789 F.3d 1335, 1341 (Fed. Cir. 2015). The claims, however, offered “no guidance on which measure of ‘molecular weight’ the claims cover,” and “the specification never define[d] molecular weight or even mention[ed] M_p , M_w , or M_n .” *Id.* at 1341, 1344–45. The method of measurement was therefore critical in defining the scope of the patent, which, again, has not been established here. Moreover, the court concluded that “average molecular weight” does not have a “plain meaning to one of skill in the art,” which is not the case for the term “not obstructing.” *Id.* at 1345.

The extrinsic evidence further illustrates how a skilled artisan would not consider the limitation “stops . . . not obstructing” to be lacking reasonable certainty in its scope under FloodBreak’s construction. *Guangdong Alison Hi-Tech Co. v. Int’l Trade Comm’n*, 936 F.3d 1353, 1361–62 (Fed. Cir. 2019) (relying on extrinsic evidence as further support for its conclusion that the challenged claim term is not indefinite). Significantly, Defendants’ expert, Smith, did not opine in his invalidity report that the limitation was indefinite. *See Sonix Tech.*, 844 F.3d at 1379. Defendants suggest that Smith did not know about FloodBreak’s construction when he performed his invalidity analysis, doc. no. 186, at 7, but I am not persuaded.

It is also noteworthy that Defendants did not argue that the limitation was indefinite throughout the first two years of litigation, even though they claimed that other limitations were

indefinite. *See Sonix Tech.*, 844 F.3d at 1379 (“That Appellees themselves did not question the clarity of ‘visually negligible’ in the first several years of litigation supports the conclusion that the term could be understood with reasonable certainty.”). Defendants again advance the argument that any delay “result[ed] only from FloodBreak’s late disclosure of the construction it was employing.” Doc. No. 186, at 8. But Defendants’ actions throughout the litigation suggest otherwise. Particularly revealing are defense counsel’s remarks at the *Markman* hearing acknowledging that “not obstructing” is connected to air flow:

[W]e've since come to realize that we don't need that exact structure. In other words, [the stops] doesn't have to be a rail. It could be an I-beam, or it could be a round rod. It doesn't have to be an oblique angle. It could be perpendicular. It could be some other angle. But it does have to be, as you said, within and connected to the device and the structure, and *it has to be not obstructing the structure when the panel doors are open, to allow the ventilation to go through.*

Tr., Doc. No. 46, at 29:6–18 (emphasis added).

Moreover, as FloodBreak asserts, Smith applied the limitation to prior art references without expressing that he had difficulty ascertaining its scope. FloodBreak’s expert likewise did not voice any difficulty in applying the limitation to the accused products. Those facts, too, weigh against a finding of indefiniteness. *Tech. Co. v. Publications Int'l, Ltd.*, 844 F.3d 1370, 1380 (Fed. Cir. 2017) (noting that the parties’ experts “repeatedly applied the term to the references and the accused products,” which “further supports the conclusion that a skilled artisan did understand the term with reasonable certainty”).

For the foregoing reasons, I conclude that the record raises no genuine issues of material fact on the defense of indefiniteness and that the “stop . . . not obstructing” limitation is not indefinite. I therefore **deny** the motion for summary judgment based on the invalidity defense to Defendants and hold that the indefiniteness defense fails as a matter of law.

IV. Conclusion

For the above reasons, I **deny** Defendants' motions for summary judgment on non-infringement or invalidity (doc. nos. 147, 165).

So ordered.

Dated at Bridgeport, Connecticut, this 6th day of August 2020.

/s/ STEFAN R. UNDERHILL
Stefan R. Underhill
United States District Judge