

# **EXHIBIT C**



US005758175A

**United States Patent** [19]

[11] **Patent Number:** **5,758,175**

**Fung**

[45] **Date of Patent:** **\*May 26, 1998**

- [54] **MULTI-MODE POWER SWITCHING FOR COMPUTER SYSTEMS**
- [75] **Inventor:** Henry Tat-Sang Fung, San Jose, Calif.
- [73] **Assignee:** Vadem, San Jose, Calif.
- [\*] **Notice:** The term of this patent shall not extend beyond the expiration date of Pat. No. 5,396,635.
- [21] **Appl. No.:** 768,331
- [22] **Filed:** Dec. 17, 1996

4,570,219	2/1986	Shibukawa et al.	395/775
4,698,748	10/1987	Juzswik et al.	395/750
4,835,681	5/1989	Culley	395/500
4,968,900	11/1990	Harvey et al.	327/544
4,980,836	12/1990	Carter et al.	364/483
5,041,964	8/1991	Cole et al.	395/750
5,083,266	1/1992	Watanabe	395/550
5,167,024	11/1992	Smith et al.	395/375
5,175,845	12/1992	Little	395/550
5,201,059	4/1993	Nguyen	395/800
5,218,704	6/1993	Watts, Jr. et al.	395/750
5,222,239	6/1993	Rosch	395/750
5,247,164	9/1993	Takahashi	235/492
5,247,655	9/1993	Khan et al.	395/550
5,396,635	3/1995	Fung	395/750.05

**Related U.S. Application Data**

- [63] Continuation of Ser. No. 459,341, Jun. 2, 1995, abandoned, which is a continuation of Ser. No. 285,169, Aug. 3, 1994, abandoned, which is a continuation of Ser. No. 17,975, Feb. 12, 1993, Pat. No. 5,396,635, which is a continuation of Ser. No. 908,533, Jun. 29, 1992, abandoned, which is a continuation of Ser. No. 532,314, Jun. 1, 1990, abandoned.
- [51] **Int. Cl.<sup>6</sup>** ..... **G06F 1/32**
- [52] **U.S. Cl.** ..... **395/750.05; 395/750.03; 395/750.01**
- [58] **Field of Search** ..... **395/800. 750, 395/750.05, 750.03, 750.01**

[56] **References Cited**

**U.S. PATENT DOCUMENTS**

3,725,868 4/1973 Malmer, Jr. et al. .... 395/375

*Primary Examiner*—Alyssa H. Bowler

*Assistant Examiner*—John Follunsbee

*Attorney, Agent, or Firm*—R. Michael Ananian; Flehr Hohbach Test Albritton & Herbert LLP

[57] **ABSTRACT**

A power conservation system for use in a computer system. The power conservation system has an activity monitor and a plurality of modes of operation. The power conservation system has a power switching unit which couples the power supply to a selected group of the computer system circuits depending upon the power mode of operation. By controlling the power mode in response to the activity of the computer system, the power consumption of the computer system can be controlled.

**28 Claims, 5 Drawing Sheets**

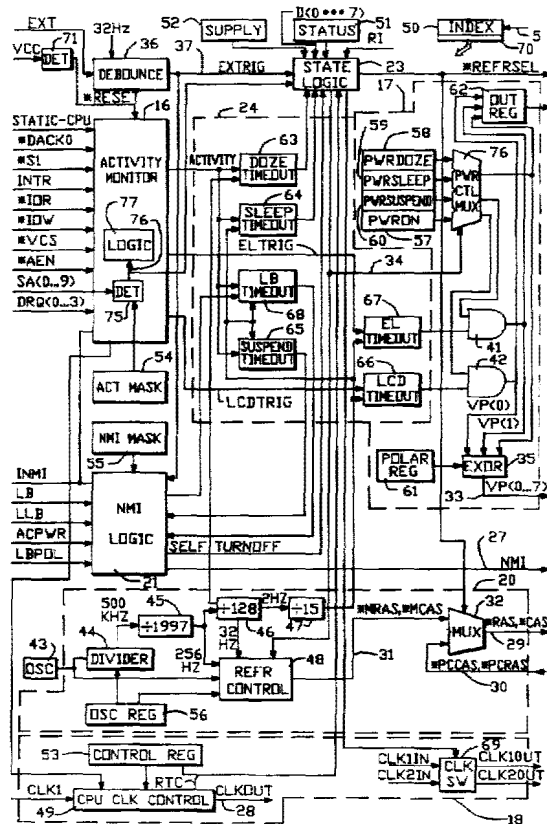

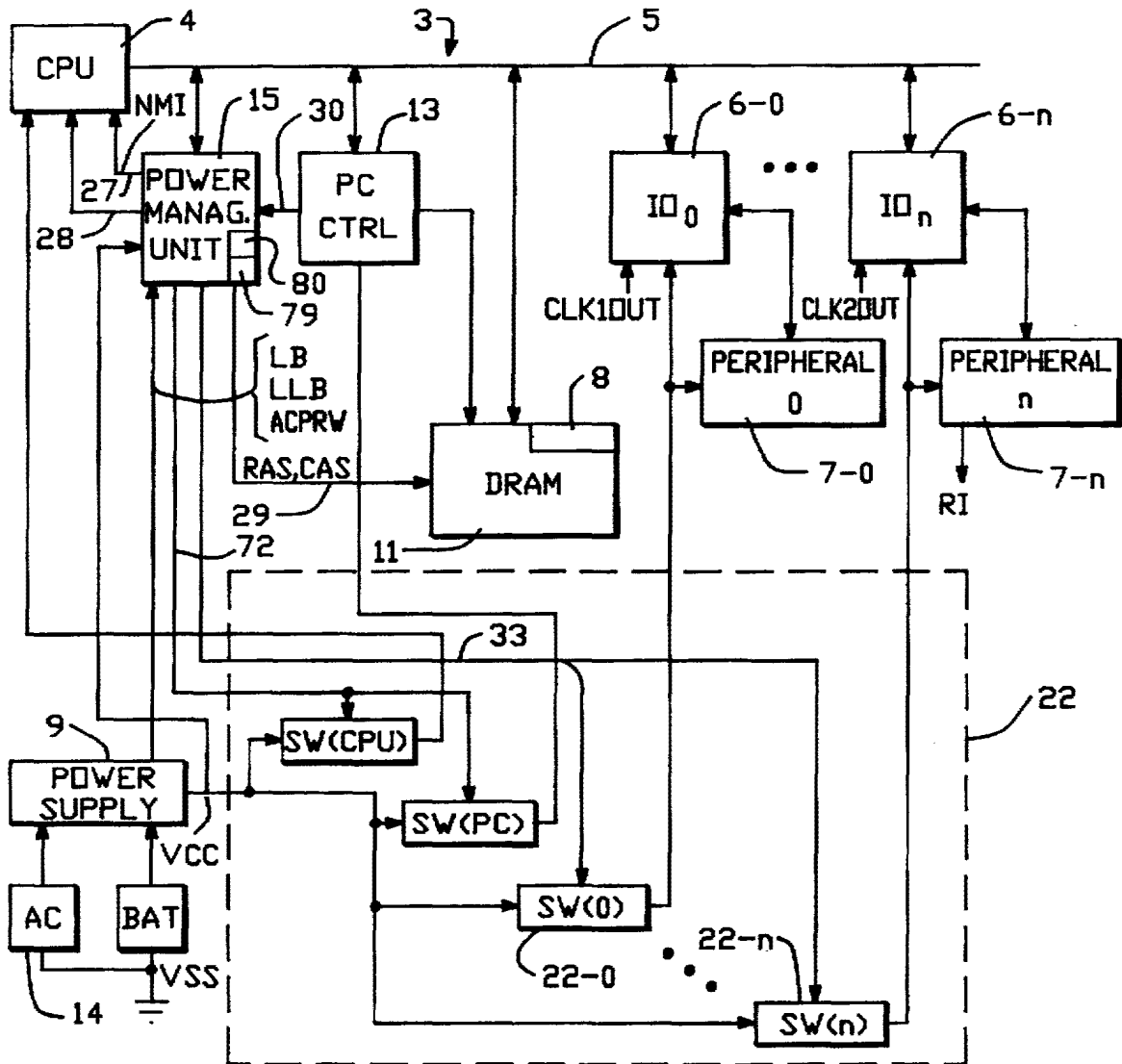

FIG. - 1

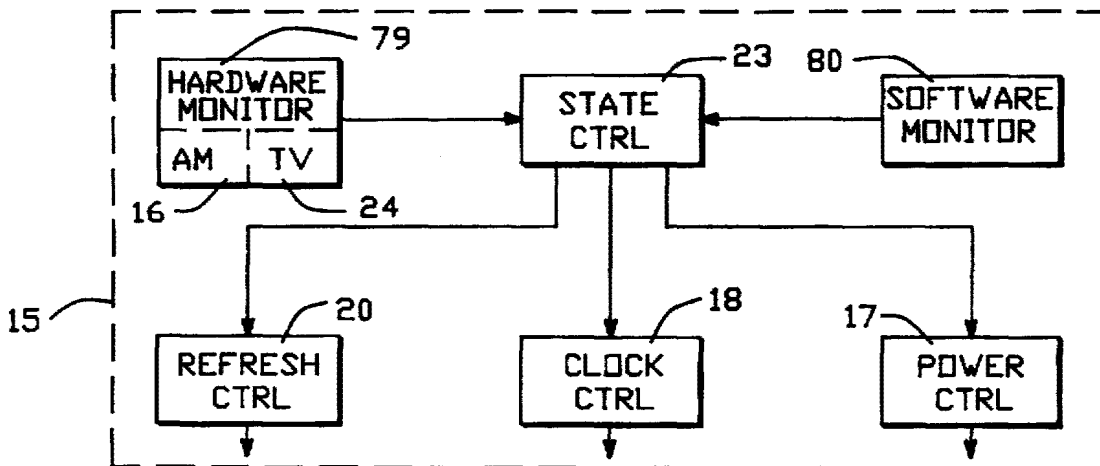

FIG. - 2

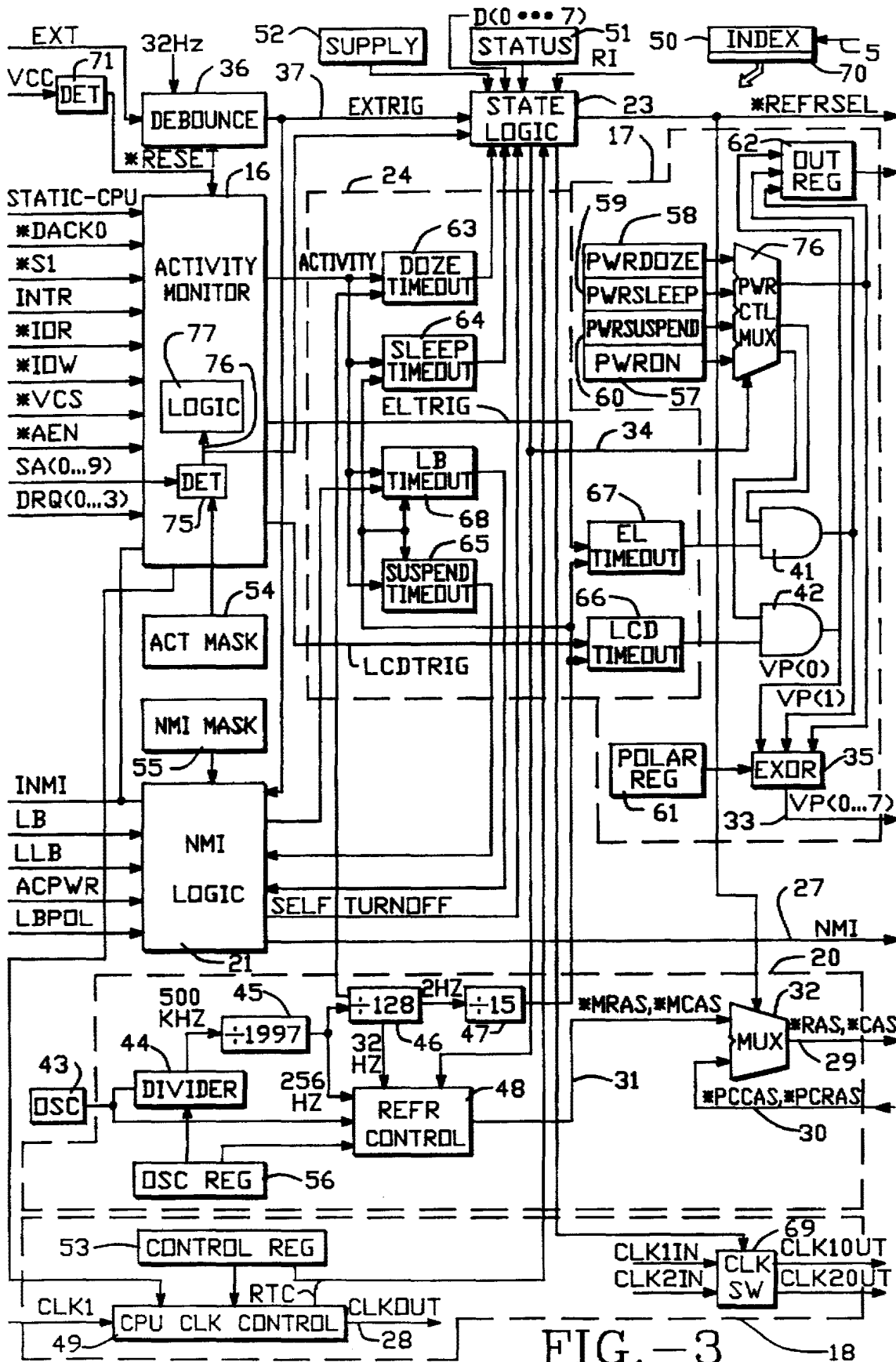
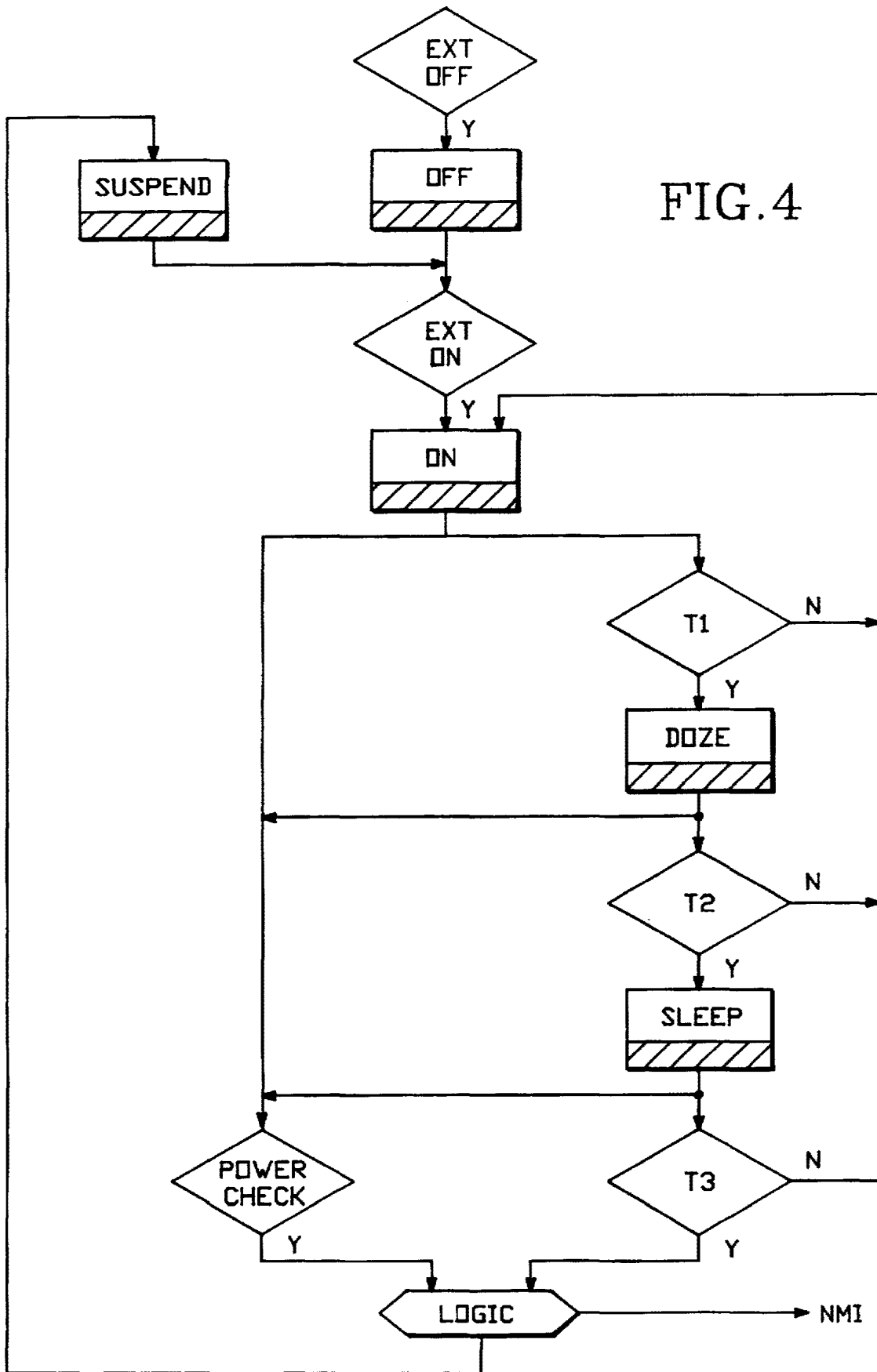

FIG. - 3

18

FIG. 4



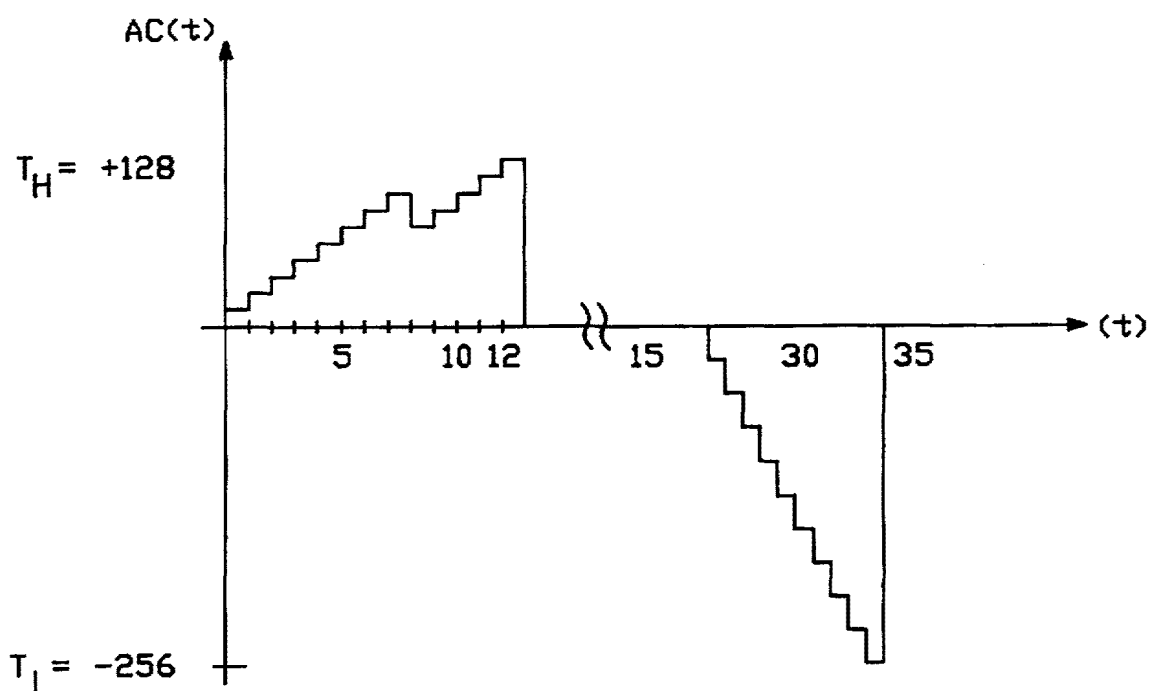

FIG. 5

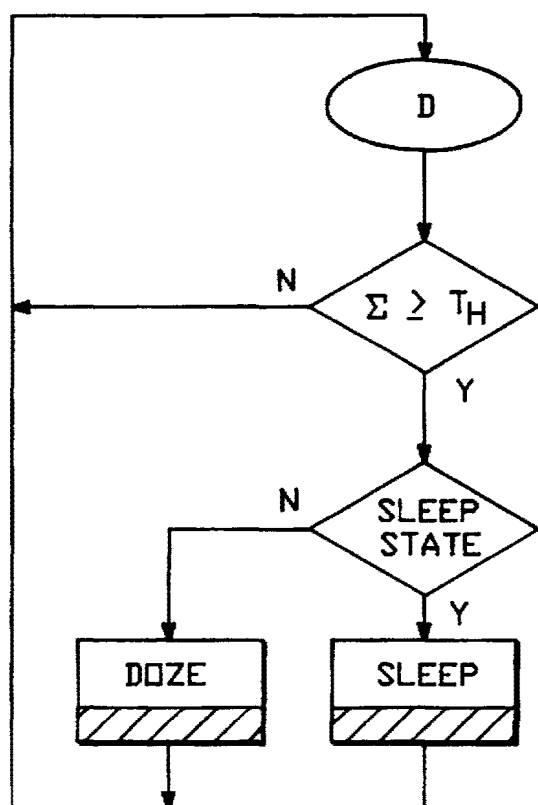

FIG. 6

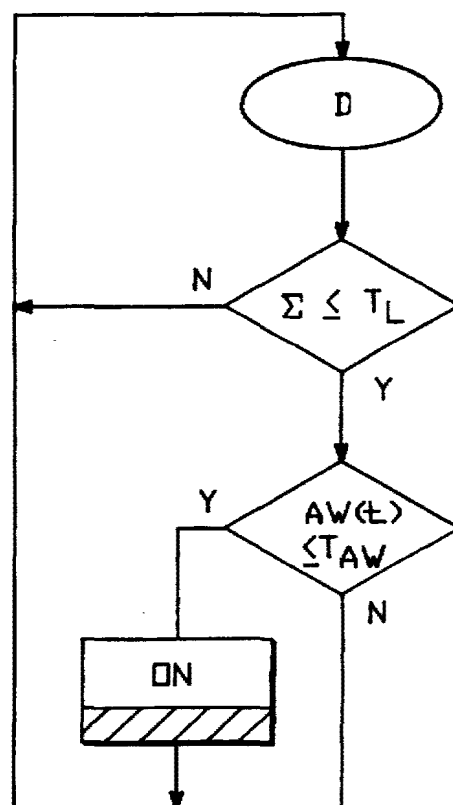

FIG. 7

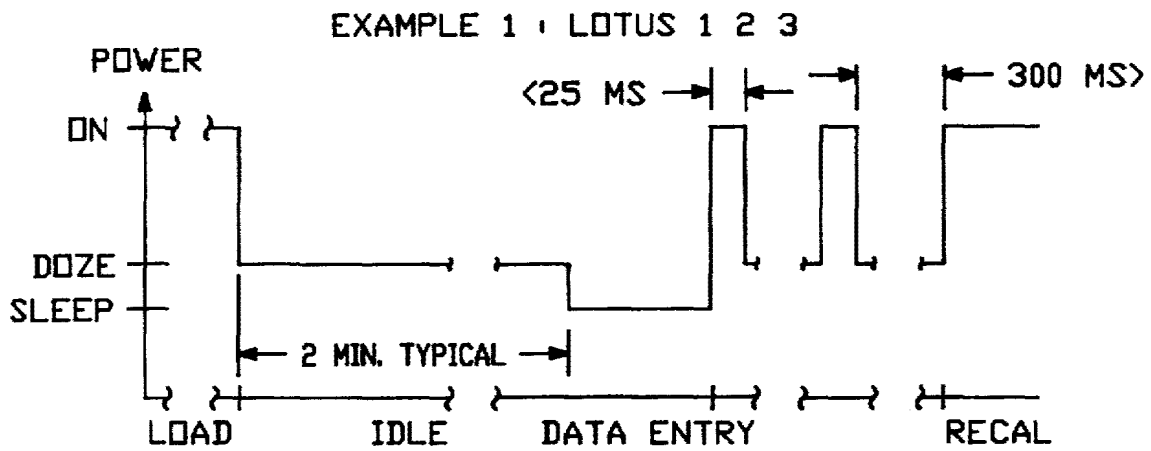

FIG.8

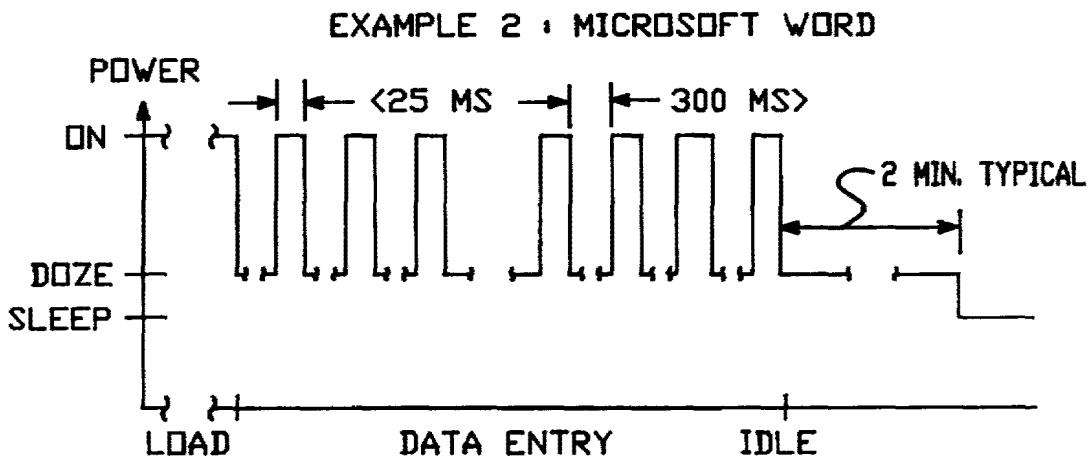

FIG.9

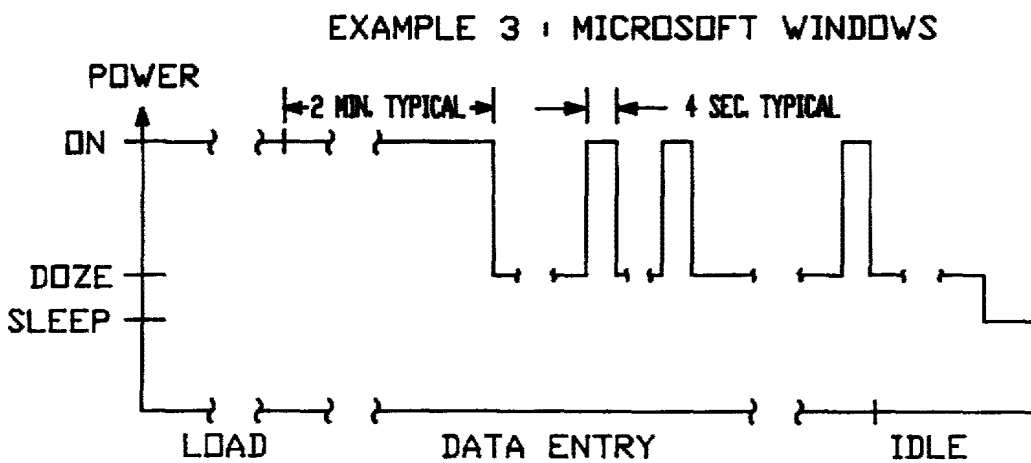

FIG.10

## MULTI-MODE POWER SWITCHING FOR COMPUTER SYSTEMS

### CROSS REFERENCE RELATED U.S. PATENT APPLICATION

This is a continuation of application Ser. No. 08/459,341 filed 2 Jun. 1995 now abandoned which is a continuation of prior application Ser. No. 08/285,169, filed 3 Aug. 1994 now abandoned, which is a continuation of application Ser. No. 08/017,975, filed 12 Feb. 1993, now U.S. Pat. No. 5,396,635, which is a continuation of application Ser. No. 07/908,533, filed 29 Jun. 1992 now abandoned, which is a continuation of application Ser. No. 07/532,314, filed 1 Jun. 1990 now abandoned.

### BACKGROUND OF THE INVENTION

A portion of the disclosure of this patent document contains material which is subject to copyright protection. The copyright owner has no objection to the facsimile reproduction by anyone of the patent document or the patent disclosure, as it appears in the Patent and Trademark Office patent file or records, but otherwise reserves all copyright rights whatsoever.

The present invention relates to computers and particularly to methods and apparatus for power management in computers, particularly in battery-powered computers.

The major parts of computers include a central processing unit (CPU), input/output (I/O) devices such as display screens, keyboards, modems, printers, disk drives and the like, and storage (memory).

The CPU communicates with the I/O devices, with the storage and otherwise operates with addresses defined within the computer address range. Typically, addresses for I/O devices are within an I/O address range. Addresses for execution of programs without I/O reference typically are within a memory address range. Similarly, that portion of memory allocated for display is within a video memory address range.

Computers function to execute application programs such as word processing, spreadsheet and data base management programs. Typically, the computer and the application programs are under the control of a software operating system that manages the different system parts and resources including some I/O devices. For example, during the execution of an application program when the CPU wishes to check to determine if any key has been depressed on the keyboard, the CPU through a subroutine call to the operating system requests the operating system through execution of a subroutine to perform a key-actuation detection task. Since the operating system performs many such tasks, the operating system has a detailed knowledge of many activities within the computer. However, under some circumstances, application programs bypass the operating system and directly address I/O devices. Typically, each I/O device is assigned an I/O address within an I/O address range. For application programs which directly address I/O devices without operating system calls, the operating system is not immediately aware of I/O activity. With such complex operation in computers, the task of power conservation is difficult.

The need for power conservation is well known in battery-powered computers and must be performed in a manner that does not interfere with the operation of the computer or impede users from interacting with the computer during the execution of application programs.

Conservation of power has been utilized for some parts of battery-powered computers but has been ignored for other

parts of such computers. In general, power consumption is distributed in battery-powered computers among the major parts of those computers. One part with significant power consumption is the central processing unit (CPU). Another part is the input/output (I/O) devices such as display screens, keyboards, modems, printers, disk drives and the like. Still another part with significant power consumption is storage (memory).

Prior art attempts at conserving power have employed screen blanking which reduces the power to the display screen when the screen has not been used for some period of time. Typically, a timeout circuit senses changes in screen information and, if no change has occurred for a predetermined timeout period, the backlight to the screen is turned off for power reduction. While screen blanking is effective in reducing power for the display screen, no reduction results in power to the driver circuitry for the display, to the CPU, or to other parts of the computer. Furthermore, when the screen is blanked, the computer cannot be used until reset.

Other prior art attempts at conserving power consumption have focused on disk drives because the power consumption of rotating magnetic disks is high. Disk drive manufacturers have employed various schemes for reducing the power consumption of the disk drive. While such power consumption schemes are effective for the disk drive, no reduction results in power to the CPU or other parts of the computer. Computers without disk drives, such as small "notebook" computers, have no need, of course, for the conservation of power in a disk drive.

In order to extend the battery life of portable computers and to manage power in computers, there is a need for improved power management methods and apparatus in computers, particularly for power management that can be extended to many different parts and conditions of the computer.

### SUMMARY OF THE INVENTION

The present invention is a method and apparatus for power management in a computer. The computer typically includes as hardware a central processing unit (CPU), storage (memory) and I/O devices and includes as software an operating system adapted to control the computer during application program execution.

The power management method and apparatus causes the computer system to enter the power conservation mode after sensing inactivity by a software monitor or by a hardware monitor.

The software monitor monitors the activity of the operating system or other software in the system. The software monitor typically is a software module linked, for example, to the operating system at boot time for monitoring subroutine calls to the operating system.

The hardware monitor monitors the hardware to detect inactivity. The hardware monitor typically is circuitry for detecting inactivity independently from the software. For example, the hardware monitor senses predetermined address ranges, such as an I/O address range and a video memory address range, and monitors the activity of addresses by the CPU to addresses within these ranges. If no data transfers occur within the specified address ranges for predetermined periods of time, then a power conservation mode is entered to conserve power in the computer system.

By using both a software monitor and a hardware monitor, the power management unit determines exactly when to enter into power conservation mode without sacrificing system performance.



In the software monitor, inactivity is determined by detecting how many "active" or "idle" function calls an application makes within some time period. In the IBM PC DOS environment, the activity status is checked, for example, no less frequently than every 50 milliseconds. There are 256 IBM PC DOS function calls and, in principle, each is labeled as "idle" or "active" and each is assigned a corresponding positive or negative number. A positive number is assigned to an "active" function call and a negative number to an "idle" function call.

The power management software monitor forms an activity measurement as a running total of the function call numbers as the function calls are made. Whenever a function call is made (either active or conservation), the power management software monitor algebraically adds the function call number to the accumulated value and determines whether the system is to remain in the active mode or be switched to the conservation mode by comparing the magnitude of the accumulated value with a function call threshold.

The function call threshold for determining activity is a variable depending on the computer system speed. To prevent the system from oscillating between the active and conservation mode due to minor changes in system activity, hysteresis is provided by using active and conservation function call thresholds. The accumulated total for the activity measurement is reset after it reaches the active threshold going in one direction or the conservation threshold going in the opposite direction as the case may be.

The active and conservation thresholds are typically unequal so that the entry and exit from conservation mode is biased. For example, in order to have the system enter the conservation mode quickly and thereby to reduce power consumption, the active threshold is set with a number greater than the number for the conservation threshold.

In one embodiment, functions that require immediate attention are assigned numbers large relative to the active and idle thresholds so that a single occurrence of the function call will force the accumulated count over the active threshold and thus force the system to be in the active mode. The hysteresis effect can be bypassed by forcing the power management unit into active mode without changing the activity count. In this case, the next idle function call will bring the system back to idle mode.

If the software monitor or the hardware monitor indicates inactivity, the power management unit enters the conservation mode. The conservation mode has multiple states which provide different levels of power conservation.

A first state, called a DOZE state, is entered after sensing inactivity by the hardware monitor for a first period of time. A second state, called a SLEEP state, is entered after sensing inactivity by the hardware monitor for a second predetermined time where the second predetermined time is greater than the first predetermined time. A third state, called a SUSPEND state, is entered after sensing inactivity by the hardware monitor for a third period of time greater than the first and second time periods.

Another state is OFF which turns off all power for the computer under predetermined conditions.

During periods of inactivity, power consumption is reduced in different ways, for example, by reducing clock speeds or removing clocks, and/or by removing power, and/or by controlling the refresh frequency to memory.

In accordance with the above summary, the present invention achieves the objective of providing an improved power management method and apparatus.

The foregoing and other objects, features and advantages of the invention will be apparent from the following detailed description in conjunction with the drawings.

#### BRIEF DESCRIPTION OF THE DRAWINGS

FIG. 1 depicts a block diagram of a computer with the power management unit of the present invention.

FIG. 2 depicts a block diagram of the power management unit of the FIG. 1 system.

FIG. 3 depicts a detailed block diagram of the hardware for the power management unit of FIG. 2.

FIG. 4 depicts a state diagram depicting the multiple states associated with the power management unit of FIGS. 1, 2 and 3 as determined by the hardware monitor.

FIG. 5 depicts a representation of operation for various states as a function of the activity measurement.

FIG. 6 depicts a state diagram depicting switching to conservation mode (DOZE or SLEEP state) operation under control of the software monitor.

FIG. 7 depicts a state diagram depicting the sequencing which forces to the ON state during an activity window period under control of the software monitor.

FIG. 8 depicts a representation of operation for a spreadsheet application program.

FIG. 9 depicts a representation of operation for a word-processing application program.

FIG. 10 depicts a representation of operation for a windowing application program.

#### DESCRIPTION OF THE PREFERRED EMBODIMENTS

##### Computer System—FIG. 1

In FIG. 1, computer 3 is typically a small, battery-powered computer such as a "notebook" computer. The computer 3 includes a CPU 4, a CPU bus 5, a plurality of I/O controllers 6-0, . . . , 6-n where "n" is a constant equal, for example, to 7. Connected to the controllers 6-0 through 6-n are plurality of peripheral devices 7-0, . . . , 7-n, respectively. The controllers and peripheral devices 6 and 7 typically include a keyboard, a display, a hard disk drive, a modem, a printer, and similar devices. Each of the controllers 6-0 through 6-n connects to the conventional computer bus 5.

Also connected to the bus 5 is the memory, which in one particular embodiment is DRAM random access memory 11. The memory 11, when of the type requiring refresh, is refreshed with \*RAS and \*CAS lines 29 under control of the PC controller 13 which provides \*PCRAS and \*PCCAS signals on lines 30 to power management unit 15 including a hardware monitor 79 and a software monitor 80. The I/O devices are separately powered through switch unit 22 and switches 22-0, . . . , 22-n by the VCC power from power supply 9 which receives power either from the battery 10 or an AC source 14. Power supply 9 is of a conventional type which supplies a low battery signal LB, a low-low battery signal LLB, and an AC power signal ACPWR to power management unit 15.

The computer 3 typically includes as software an operating system adapted to control the computer system and to control operations during application program execution. Computer 3 functions to execute application programs such as word processing, spreadsheet and data base management programs. Computer 3, during the execution of application programs, is under control of a software operating system.

The operating system manages the different system parts and resources including the I/O devices 6 and 7. For example, during the execution of an application program when the CPU wishes to check to determine if any key has been depressed on a keyboard I/O device, the CPU 4 through a subroutine call to the operating system requests the operating system to execute a subroutine to perform a key-actuation detection task. Since the operating system performs many similar calls to the operating system, these calls represent detailed information about many activities within the computer system.

In FIG. 1, the computer 3, through the CPU 4, issues control and address signals on the bus 5 which define the overall computer address range for computers including the sets of address ranges for all of the memory, I/O and other devices connected to the bus 5. Whenever any of the peripherals 7-0 to 7-n are to be accessed for data to be transferred over the bus 5, the address of the corresponding I/O controller 6-0 to 6-n (either by unique address lines or unique address lines in combination with control lines) specifies the addressed one of the I/O controllers 6 and corresponding peripheral 7.

Similarly, memory 11 has locations addressed by a set of addresses on bus 5 within a memory address range. Some of the addresses in the range of addresses for memory 11 are typically allocated and reserved only as a set of video memory addresses. Whenever the video memory region 8 of memory 11 is to be addressed, address appears on bus 5 within the set of video memory addresses.

The computer system of FIG. 1 includes a power management unit 15 having a software monitor 80 and a hardware monitor 79 for monitoring activity of the computer system. The power management unit 15 is connected to the bus 5 to sense activity, using hardware monitor 79, on the bus 5 and is connected to the CPU 4 (executing the operating system and the software monitor 80), the power supply 9, the memory 11 and PC controller 13 for controlling power management.

The power management unit 15 of FIG. 1 operates to cause the computer system to enter the power conservation mode after sensing inactivity by the hardware monitor 79 or by the software monitor 80 and to enter the active mode after sensing activity or other conditions.

The hardware monitor 79 monitors the hardware to detect inactivity. The hardware monitor 79 typically is circuitry for detecting inactivity independently from the software and the software monitor 80. For example, the hardware monitor 79 senses predetermined address ranges, such as an I/O address range and a video memory address range, and monitors the activity of addresses by the CPU to addresses within these ranges. If no data transfers occur within the specified address ranges for predetermined periods of time, then a power control mode is entered to conserve power in the computer system.

The software monitor 80 monitors the activity of the operating system or other software in the system. The software monitor 80 typically is a software module linked, for example, to the operating system at boot time for monitoring subroutine calls to the operating system.

By using a software monitor 80 and a hardware monitor 79, the power management unit 15 decides exactly when to enter into power conservation mode and active mode without unnecessarily sacrificing system performance.

The power conservation mode includes a number of activity states. A first state, called a DOZE state, is entered after sensing inactivity for a first period of time by the

hardware monitor or when an idle threshold is exceeded as determined by the software monitor. A second state, called a SLEEP state, is entered after sensing inactivity by the hardware monitor for a second predetermined time where the second predetermined time is greater than the first predetermined time or when the activity measurement sensed by the software monitor exceeds the idle threshold. A third state, called a SUSPEND state, is entered after sensing inactivity for a third period of time greater than the first and second time periods. Another state is OFF which turns off all power for the computer under predetermined conditions.

After having entered one or more of the activity states of the conservation mode, the power management unit switches back to the active mode when activity is sensed by the monitors.

### Power Management Unit—FIG. 2

In FIG. 2, a block diagram of the power management unit 15 of FIG. 1 is shown. The power management unit includes a hardware monitor 79 (including an activity monitor 16 and a timer unit 24), a software monitor 80, a state control unit 23, a power control unit 17, a clock control unit 18, and a refresh control unit 20. The hardware monitor 79 (using activity monitor 16) analyzes the address activity on the system bus 5 to provide activity information used to control power management. The timer unit 24 times the activity information sensed by the monitor 16. The state control unit 23 controls the changes among different power consumption states to achieve power management.

The power control unit 17 controls the switches 22-0, . . . 22-n of FIG. 1 as a function of the activity sensed by activity monitor 16 and the state determined by state control unit 23.

The clock control unit 18 controls the distribution of and/or the frequency of the CPU and other clocks as a function of the activity sensed by the activity monitor 16 and the state determined by state control unit 23.

The refresh control unit 20 controls the refresh of the RAM memory 11 of FIG. 1 at a rate which is determined by the activity sensed by the activity monitor 16 and state control unit 23.

The power management unit (PMU) 15 is provided to manage power and reduce, over time, the overall power consumption of computer 3. This management is accomplished using an activity monitor 16 to detect periods of system inactivity. During periods of inactivity, power consumption is reduced by reducing clock speeds or removing clocks through clock control unit 18, and/or by removing power through power control unit 17, and/or by controlling the refresh frequency through refresh control unit 20. Standard and slow refresh DRAM support is provided by refresh control unit 20. Inputs are provided to the power management unit 15 which will allow power on or off commands from external sources such as a pushbutton, modem ring indicator, or read-time-clock (RTC) time of day alarm.

### Hardware Monitor Generally—FIG. 3

Referring to FIG. 3, the power management unit (PMU) 15 includes the hardware monitor 79 (activity monitor 16 and timer unit 24) which is designed to operate with minimal system requirements and without software support. Power management occurs in response to the hardware monitor independently of any operating system (DOS) or application program support.

In FIG. 3, the PMU 15 has its own power-on reset signal (\*RESET) which is produced by a VCC power detector 71, separate from any other reset signal of computer 3, and upon initial power-on, the registers of the power management unit 15 are initialized to preestablished default values to provide basic functionality without need of any software.

While the hardware monitor 79 and the power management unit 15 are provided FIG. 3 as a hardware embodiment, a software embodiment of the hardware monitor 79 is described in the program listing of TABLE 1. Using the program listing of TABLE 1 executing in the CPU 4, power management, using a software embodiment of a hardware monitor, occurs under program control.

In accordance with the operation of the hardware monitor 79, a predetermined set of address ranges on bus 5 is monitored by power management unit 15 as part of the power management operation. For example, the predetermined set of address ranges monitored for power management typically includes all of the I/O address range, that is, the addresses of the I/O controllers 6-0 through 6-n and the video memory address range for the video memory locations 8 within the memory 11. Of course, other address ranges can be added to or used as the predetermined set for power management. The set of address ranges including the video memory and the I/O address ranges has been found to provide excellent information for controlling power management.

The hardware monitor 79 senses the activity of addresses on the bus 5. Whenever addresses within the predetermined set of addresses are not present on the bus 5 for predetermined time periods, the power management unit 15 responsively switches power consumption states and controls the consumption of power by different parts of the computer 3.

The power management unit 15 has four main operating states, namely, ON, DOZE, SLEEP, and SUSPEND, and a fifth state which is OFF. The five power management states, under control of the hardware monitor 79, are shown by the state diagram of FIG. 4. The activity monitor 16, external inputs (EXT, RESET), and the timeouts of timer unit 24 generally control the transitions between states in the state control unit 23 as shown in the state diagram of FIG. 4. The CPU 4 of FIG. 1 may also command the PMU 15 to enter any state. The commands from the CPU 4 typically derive from execution of the software monitor 80, but may derive from other CPU 4 commands.

In FIG. 3, each of the four active states (not OFF) has an associated PWR register which indicates in one embodiment which of eight power control outputs VP[0 . . . 7] on lines 33 will be active during the state. More generally, any number, (n+1), outputs VP[0 . . . n] can be employed. The PWR registers in power control unit 17 are PWRON register 57, PWRDOZE register 58, PWR SLEEP register 59 and PWR SUSPEND register 60 as shown in FIG. 3. A power control multiplexer 76 selects the eight outputs from one of the registers 57 through 60 corresponding to the current state on STATE lines 34 from unit 23, and these eight outputs drive the VP[0 . . . 7] power control outputs from EXOR unit 35. Also, the CPU 4 of FIG. 1 can write, under program control, to any of the PWR registers 57 through 60 to control which of the I/O devices 6 and 7 are powered at any time.

To turn an I/O device on, the corresponding bits in the PWR registers 57 through 60 for the state(s) in which they are to be on is typically high. The POLARITY register 61 specifies the actual polarity of each output VP[0 . . . 7] required to turn the associated one of the switches 22-0, . . . 22-n on and thereby supply power to the I/O devices 6 and

7. The default value of the POLARITY register is 03h, which implies a logic low to turn on VP[2 . . . 7], which will typically control logic switches 22 with low-true output enables (for example, switches 22 typically include a PNP transistor in the VCC line from power supply 9) and high to turn on the LCD, VP[0], and EL backlight, VP[1], power. The value of the VP[0 . . . 7] bits just prior to the polarity control by EXOR 35 may be read back through the OUTPUT register 62 to CPU 4 over bus 5.

The system clock oscillator signal CLKI is connected to the CPU Clock Control block 49 to produce the CLKOUT. From there CLKOUT, as controlled by PMU 15 and control block 49, drives CPU 4. The CLKOUT clock can be stopped for static CPU's, or reduced automatically by a divisor specified in the CLOCK field of control register 53 during DOZE and SLEEP states. CLKI is passed through unchanged to CLKOUT in SUSPEND state.

Detailed implementations of the various monitor, control and logic blocks of FIG. 3 will be clear from the following detailed description. Additionally, a software embodiment of the hardware monitor 79 including logic and control functions equivalent to those in the hardware embodiment appears as the Program Listing of TABLE 1.

#### Software Monitor Generally

The software monitor 80 of FIG. 2 includes a power management software module linked into the operating system, for example, during boot up time. One embodiment of the module appears as the program listing of TABLE 2.

The software monitor 80 monitors all the function calls to the operating system. Every time an idle function call is made, the activity measurement, AC(t), is incremented and then checked against thresholds. The incrementing is algebraic by the amount of  $D_a$ , a positive DOS call number, or  $D_i$ , a negative DOS call number.

If the activity measurement, AC(t), is below the idle threshold,  $T_H$ , and the system is in the active mode, no action will be taken. However, if the activity measurement, AC(t), is above the idle threshold,  $T_H$ , the power management software will check the current system status and if in the active mode, will switch to the conservation mode.

The activity measurement, AC(t), is given by the following Eq. (1):

$$\sum D_a(t) + D_i(t) = AC(t) \quad \text{Eq. (1)}$$

where,

$D_a(t)$ =Active DOS call numbers as a function of time

$D_i(t)$ =Idle DOS call numbers as a function of time

AC(t)=Accumulated Activity Count of DOS call numbers as a function of time, that is, activity measurement

While all of the interrupts of the operating system may be assigned a  $D_a$  or  $D_i$  value the following, for example in the following CHART 1.

CHART 1

INTERRUPT	CALL NUMBER	TYPE
I16 (keyboard poll)	+12	Di
I10 (video active)	-25	Da
I8 (timer)	-25	Da
I14 (communications)	-400	Da

Using the values in CHART 1, each time an interrupt 16 (I16) occurs, the software monitor increments AC(t) by +12 and each time I10 or I8 occurs the software monitor incre-

ments  $AC(t)$  by  $-25$ . The value of  $AC(t)$  is shown for one example of operation in FIG. 5.

Referring to FIG. 5, the value of  $AC(t)$  as a function of  $t$  is shown. In the example of FIG. 5, the first eight values of  $t$  find keyboard polling occurring by the I16 interrupt so that  $+12$  is added to  $AC(t)$  for each of the first eight values of  $t$ . In FIG. 5, at  $t=8$ , the timer interrupt I8 occurs and subtracts  $-25$  from the  $AC(t)$  value. Thereafter the keyboard polling continues until the value of  $AC(t)$  reaches 128, the value of  $T_H$  in the example of FIG. 5. At  $t=12$  in FIG. 5,  $AC(t)$  is reset, for example, to 0 when the computer system enters the conservation (idle) mode. At about  $t=20$  in FIG. 5, which may include a long time duration generally indicated by the broken line at about  $t=15$ , video interrupt I10 becomes active and starts to add  $-25$  to the  $AC(t)$  value until at about time  $t=35$  the value of  $AC(t)$  reaches the  $-256$  value of the threshold  $T_L$ .

When the value of  $AC(t)$  is above  $T_H$ , then the software monitor is operative to switch the computer system into the conservation mode. Whenever  $AC(t)$  is in below the threshold  $T_L$ , the software monitor is operative to switch the computer system back to the active mode.

The example of FIG. 5 is only for purposes of representing the manner in which  $AC(t)$  is incremented as a function of the positive and negative interrupt call numbers. Of course, other counting methods may be employed. In the program of TABLE 2, after the  $T_H$  value of  $+128$  is reached, the counter is reset to  $+256$  and each value of  $Da$  decrements the count until the threshold  $T_L$  is reached at 0.

The operation which occurs when the value of  $AC(t)$  exceeds the threshold  $T_H$ , is explained with respect to the flowchart of FIG. 6.

In FIG. 6, the value of  $D$  (either  $Da$  or  $Di$ ), the interrupt number value, is added as indicated in Eq. (1) to form the accumulation value of the activity measurement,  $AC(t)$ . This accumulation is indicated by the oval marked  $D$  in FIG. 6.

Next, the value of  $AC(t)$  is compared with the threshold  $T_H$ . If the value of the summation in Eq. (1) is not greater than the threshold,  $T_H$ , then the  $N$  no choice is made the loop repeats so that the next value of  $D$  is added to the  $AC(t)$  activity measurement. For example, in FIG. 5, this activity continues until approximately  $t=12$  in FIG. 5.

In FIG. 5, at about  $t=12$ , the activity measurement  $AC(t)$  equals or exceeds the threshold  $T_H$  and hence the  $Y$  output of the comparison connects to the SLEEP state detector. If already in the state, then the  $Y$  output will force the computer system to remain in the SLEEP state. If not in the SLEEP state, then the software monitor will force the computer system into the DOZE state.

Note that the FIG. 6 operation will force the computer system into the DOZE or SLEEP state as long as the activity measurement  $AC(t)$  exceeds the threshold  $T_H$ . When the threshold  $T_H$  has been exceeded,  $AC(t)$  is reset and remains reset until another activity event,  $Da$  or  $Di$ , occurs. In FIG. 5, for example, this occurs at about  $t=20$  when  $AC(t)$  begins to count toward  $T_L$ .

In addition to the comparison of the activity measurement  $AC(t)$  against the upper threshold  $T_H$ , the software monitor 80 also compares the value of the activity measurement against the lower threshold  $T_L$ . This comparison is represented by the flowchart of FIG. 7.

In FIG. 7, the oval represents the incrementing of the activity measurement  $AC(t)$  in accordance with Eq. (1). After each incrementing of the activity measurement, the value of  $AC(t)$  is compared to determine if it is less than or equal to  $T_L$ . If not, then the  $N$  output of the comparison continues the incrementing of the activity measurement for each new value determined in accordance with Eq. (1).

If the activity measurement  $AC(t)$  is less than or equal to  $T_L$ , then the  $Y$  output of the comparison connects the operation to the activity window comparison.

If  $AC(t) \leq T_L$  and  $AW(t) \leq T_{aw}$ , then the FIG. 7 operation switches to the ON state.

If  $AC(t) \geq T_H$ , then test sleep state. where,

$$\begin{aligned} T_H &= K_1 \\ T_L &= K_2 \\ T_H &= \text{Idle Threshold} \\ T_L &= \text{Activity Threshold} \\ K_1 &= 128 \\ K_2 &= -256 \end{aligned}$$

### Combined Hardware Monitor and Software Monitor Operation

If the system is in ON state and  $AC(t)$  is greater than or equal to  $T_H$ , the power management software monitor will bring the system into DOZE state. If the system is already in DOZE or SLEEP state, no further action will be needed. Similarly, the activity count,  $AC(t)$ , will be decremented every time an active function call,  $Da$ , is made. The activity count is then used to compare with the active threshold. If the count is higher than the active threshold,  $T_H$ , then the power management software monitor 80 will force the system into the power conservation mode (DOZE or SLEEP) per the FIG. 6 operation regardless of the status of the hardware monitor 79. If the activity count is equal to or less than the active threshold,  $T_L$ , then the system will be programmed into the ON state.

The ON state can also be entered if the hardware monitor 79 detects a predetermined set of address ranges on bus 5. For example, the predetermined set of address ranges monitored for power management typically includes all of the I/O address range, that is, the addresses of the I/O controllers 6-0 through 6-n, and the video memory address range for the video memory locations 8 with the memory 11. Of course, other address ranges can be added to or used as the predetermined set for power management. The set of address ranges including the video memory and the I/O address range has been found to provide excellent information for controlling power management.

After entering the ON state, the power management unit will continue to be in the ON state until any idle function call detects the activity count has reached or gone beyond the idle threshold,  $T_H$ .

There are application programs such as Microsoft's Windows described in connection with FIG. 10 that do not use the DOS idle function calls and therefore the system would never go into the DOZE state through operation of the software monitor 80. Therefore, a watch dog timer is built into the power management software monitor to monitor the absence of idle function calls as indicated in connection with FIG. 7. If a time period greater than  $T_{aw}$ , as shown in the flow chart in FIG. 7 has been exceeded without any idle function call being made, then it is assumed that the application program bypasses DOS and goes directly to the hardware.

During the  $T_{aw}$  time period (see FIG. 7) the power management unit will be forced into the ON state until detection of activity for predetermined period of time,  $T_{aw}$ . This period,  $T_{aw}$  is normally more than a minute in order not to affect the system performance. There is no power saving during the time out period,  $T_{aw}$ , even if the CPU is actually

idling. After the  $T_{aw}$  time period, the hardware monitor 79 will take over completely.

In most cases, application programs go through DOS to perform I/O operations. The power management software monitor 80 keeps track of all the operating system function calls. If the accumulative count of all active and idle function calls is greater than the upper threshold,  $T_H$ , then the system is assumed to be inactive. The power management software monitor will program the power management unit to DOZE state only if the system is still in ON state. The computer 3 will enter DOZE state without waiting for the ON state timer to expire and therefore maximizes the power saving of the system. If computer 3 is already in DOZE or SLEEP, no action will be needed from the power management software monitor until the system becomes active again.

In the software monitor 80, inactivity is determined by detecting how many active or idle function calls an application makes within some time period. In the IBM PC DOS environment, the activity status is checked no less frequently than every 50 milliseconds. There are 256 IBM PC DOS function calls and each is labeled as idle or active with a corresponding positive or negative number. A positive number is assigned to an active function call and a negative number to an idle function call. The power management software module keeps a running total of the accumulated value of the function call numbers as the function calls are made. Whenever a function call is made, (either active or idle), the power management software module algebraically adds the number to the accumulated value and decides whether the system is active or not by comparing the magnitude of the accumulated value with a function call threshold. The function call threshold for determining activity is a variable depending on the computer system speed.

To prevent the system from oscillating between the active and idle state due to minor changes in system activity, hysteresis is provided by using active,  $T_L$ , and idle,  $T_H$ , function call thresholds. The accumulated total is clamped at  $T_H$  after it reaches the active thresholds  $T_H$  or  $T_L$  as the case may be. The active and idle thresholds are typically unequal (128 and -256) so that the entry and exit from conservation (idle) mode is biased. For example, in order to have the system enter the idle mode quickly and thereby to reduce power consumption, the active threshold is set with a threshold number (128) greater than the idle threshold number (-256). Also, functions that require immediate attention are assigned numbers large relative to the active and idle thresholds so that a single occurrence of the function call (for example, 114=-400) will force the accumulated count over the active threshold ( $T_L=-256$ ) and thus force the system to be in the active mode. The hysteresis effect can be bypassed by forcing the power management unit into active mode without changing the activity count. In this case, the next idle function call will bring the system back to idle mode.

If the software monitor 80 or the hardware monitor 79 indicates inactivity, the power management unit enters the conservation mode which has multiple states with different levels of power conservation.

The hardware monitor 79 works in conjunction with the software monitor 80 linked to the operating system during boot up time. The state control unit 23 is controlled by the timer unit 24 and power management software module 100. The power management software will override the hardware timer unit 24 whenever inactivity is detected in the operating system level. Since this can be done in a much finer

resolution than the hardware monitor 79, the combined software and hardware monitor maximize power saving without any degradation in system performance.

#### Power Management Unit Detail—FIG. 3 Line List

In FIG. 3, the following lines and functions are defined for the connections output (O) from and input (I) to the PMU 15 of FIGS. 1 and 2.

Name	Type	Function
SA[0..9]	I	System Address on bus 5
SD[0..7]	I/O	System Data on bus 5
VP0	O	LCD power control
VP1	O	EL backlight power control
VP[2..7]	O	Peripheral power control
*RAS	O	*RAS for DRAM
*CAS	O	*CAS for DRAM
*PCRAS	I	*RAS for DRAM
*PCCAS	I	*CAS for DRAM
*VCS	I	Video RAM chip select
*IOR	I	I/O Read
*IOW	I	I/O Write
*S1	I	Status, low indicates read or read operation
AEN	I	DMA enable
INMI	I	NMI input from user system
NMI	O	NMI output to CPU
INTR	I	Int request output of computer
DRQ[0..3]	I	DMA requests which could occur in DOZE or SLEEP
*DACKO	I	Indicates refresh DMA cycle
EXT	I	External command input (button)
RI	I	Ring indicator from modem
RTC	I	Alarm output from RTC
CLKI	I	CPU clock input
CLKOUT	O	Clock out to CPU
LB	I	Low battery detect, first warning
LLB	I	Low battery detect, second warning
ACPWR	I	AC power good input
*RESET	I	External RC required for reset
*REFRSEL	O	Low when PMU controls DRAM refresh
OSC	I	Xtal osc output
CLK1IN	I	Clock 1 in for switched clock 1 out
CLK1OUT	O	Switched clock 1 out
CLK2IN	I	Clock 2 in for switched clock 2 out
CLK2OUT	O	Switched clock 2 out
LBPOL	I	Low battery polarity select
STATIC_CPU	I	Connect to Vcc if CPU is static
VCC		Power
VSS		Ground

#### Registers

In FIG. 3, the PMU 15 includes a number of registers accessed for read or write by CPU 4 over bus 5 via an index register addressing scheme. When not accessed by CPU 4, for example, after a power on detection by detector 71, the registers are all initialized to a default state. When accessed by CPU 4, an index value is first written to the index register 50 from bus 5 and the index value is decoded by decoder 70 to select one of the registers of PMU 15 for access to bus 5 to receive or send information from or to CPU 4. The index register 50, after an index write, is changed to point to another register to be accessed. When reset, the index register is not active to enable any PMU 15 register. This is a safety feature to help prevent applications executing on the CPU 4 from inadvertently accessing PMU 15 registers. All registers may be read and written over bus 5.

The PMU 15 data registers are:

Data Register (Ref. No.-FIG. 3)	Index	Decode
STATUS	51	00H
SUPPLY	52	02H
CONTROL	53	04H
ACTMASK	54	06H
NMIMASK	55	08H
OSC	56	0AH
PWRON	57	0CH
PWRDOZE	58	0EH
PWRSLEEP	59	10H
PWRSUSPEND	60	12H
POLARITY	61	14H
OUTPUT	62	16H
DOZE	63	18H
SLEEP	64	1AH
SUSPEND	65	1CH
LCD	66	1EH
EL	67	20H

Status Register

Bit	Name	Function
D7	RESUME	Resuming from SUSPEND (warm start)
D6	WU1	Wakeup code MSB
D5	WU0	Wakeup code LSB
D4	NMI2	\
D3	NMI1	> NMI cause code
D2	NMI0	/
D1	STATE1	State MSB
D0	STATE0	State LSB

In register 51, only D0 and D1 are affected by a write. The CPU 4 can write the state code to this register to put the PMU in another state. Writing OFFh puts it in the OFF state. The NMI cause, state and wakeup codes are decoded as follows:

Code	Wakeup	NMI Cause	Code	State	Code	Cause
000		None, or INMI	00	On	00	
001		EXT input	01	DOZE	01	E X T
010		LB	10	SLEEP	10	R T C
011		LLB timeout	11	SUSPEND	11	R I
100		SLEEP timeout				
101		SUSPEND timeout				

\*RESET sets STATE[0..1] and clears all other bits.

Supply Register

This register 52 is read only. D[0 . . . 2, 5] are driven directly by the input lines. Bit D3 is set when system activity is detected and is cleared when this register is read.

Bit	Name	Function
D5	STATIC_CPU	1 = Static CPU (clock stops in DOZE)
D4	DRAMRDY	1 = CPU controls DRAM (same as *REFRSEL)
D3	ACTIVITY	System activity present
D2	LLB	Low battery 2 (second warning)

-continued

Bit	Name	Function
D1	LB	Low battery 1 (first warning)
D0	ACPWR	AC power input in range

Control Register

Bit	Name	Default	Function
D7		0	
D6	RING2	0	\
D5	RING1	0	> Number of RI pulses required for turnon
D4	RING0	1	/ default = 1
D3	STATIC_CPU	0	For static CPU's
D2	SLOW	0	Clock runs slow in ON
D1	CCLK1	1	CPU Clock divisor, DOZE and SLEEP
D0	CCLK0	0	/ default divisor = 4

In register 53, the RING[0 . . . 2] bits are used to set the number of RI pulses required for turnon. The default value is 1 so that only one pulse is required for turnon. If set to 0, RI is disabled. State logic 23 has conventional logic for detecting and counting RI pulses from a modem, one of the I/O peripherals 7-0 to 7-n. D3 is only used for static CPU's. SLOW indicates reduced clock speed operation in On. The CCLK[0 . . . 1] bits select the clock divisor for CLKOUT in SLEEP and DOZE states, and in ON if SLOW is set, according to the table.

CCLK[0..1] Divisor

0	1
1	2
2	4
3	8

ACTMASK Register

Bit	Name	Default	Function
D7		0	
D6	MSK_VIDM	0	Mask access to video memory
D5	MSK_DMA	0	Mask all DMA activity
D4	MSK_P63	1	Mask access to port 63h
D3	MSK_PIC2	0	Mask access to port A0h, A1h
D2	MSK_RTC	1	Mask access to port 70h, 71h
D1	MSK_KBD	0	Mask keyboard (port 60H, 64H)
D0	MSK_IO	0	Mask access to all ports not maskable by D[2..5]

The activity monitor ACTIVITY output is the logical OR of all unmasked activity sources. This register 54 affects only the ACTIVITY output. Refresh DMA cycles (\*DACKO low), interrupts, or accesses to the PMU 15, never affect the activity monitor 16.

NMIMASK Register

This register 55 masks the various NMI sources. In the default state only the INMI input can generate NMI.

Bit	Default	Name	Function	
D6		OS2	Mask INMI input	0
D5		MSK_SUSPEND	Mask SUSPEND timeout	1
D4		MSK_SLEEP	Mask SLEEP timeout	1
D3		MSK_LLB	Mask LLB input	1
D2		MSK_LB	Mask LB input	1
D1		MSK_EXT	Mask EXT input	1

## OSC Register

Bit	Name	Default	Function
D7	OSCDIV3	1	\
D6	OSCDIV2	1	OSC input divisor -1
D5	OSCDIV1	0	default code = 1101 (divisor = 14)
D4	OSCDIV0	1	/
D3			
D2	SLWREF	0	Slow refresh DRAM
D1	RASWIDTH1	0	*RAS pulse width MSB
D0	RASWIDTH0	0	*RAS pulse width LSB

Referring to register 56, OSCDIV[0 . . . 3] plus one is the OSC frequency in MHz, except for OSCDIV[0 . . . 3]=13, the default, indicates 14.318 MHz. SLWREF is set when slow refresh DRAM is used. RASWIDTH[0 . . . 1] indicates the width of the \*RAS pulse in units of OSC periods. The default value is 0 which disables refresh in SUSPEND state, and no RAS/CAS is generated. Values of 1 to 3 indicate 1 to 3 OSC periods.

## PWR Registers

The bits D[0 . . . 7] in these registers 57 through 60 correspond directly with the power control outputs VP[0 . . . 7]. In a particular state, the corresponding PWR register outputs control the VP lines 23. The exception is VP0 and VP1 which are LCD and EL power, respectively. These outputs are AND'ed in AND gates 41 and 42 with the LCD and EL timer outputs prior to driving the lines 33. All bits are then exclusive NOR'ed in gates 35 with the POLARITY register 61, and the result drives the lines 33. The default values for these registers are as follows, where 1 indicates that the controlled device is on:

PWRON	FFh
PWRDOZE	FFh
PWRSLEEP	0Fh
PWRSUSPEND	00h

## POLARITY Register

This register 61 controls the polarity of the VP outputs. If a logic low is required on a VP line to turn the external device on, the corresponding bit in the POLARITY register 61 must be low. If a high is required, set the bit high. The default value is 03h.

## Timer Registers

The nonzero value loaded into one of the timer registers 63 through 68 is the actual timeout minus one. A zero disables the timeout. Therefore a 4 bit timer can be set for a timeout from 1 to 15 time units. Reading a timer register

returns the value that was last written to it, not the actual time remaining. The default values are tabulated below:

Timer	Range	Default
DOZE	1-15 sec	5 sec
SLEEP	1-15 min	2 min
SUSPEND	5-75 min	0 (disabled)
LCD	1-15 min	TBD
EL	1-15 min	TBD

## OUTPUT Register

The OUTPUT register 62 is a read only register. For each VP[0 . . . 7] output that is on, the corresponding bit in the OUTPUT register will be set.

The control and logic functions for the activity monitor 16, the state logic 23, the NMI logic 21, and other components of FIG. 3 are conventional logic circuits for implementing the logic and control functions hereinafter described or alternatively are the software logic of TABLE 1.

## ON State

Referring to FIG. 4, the ON state is entered from the SUSPEND or OFF state when the \*RESET input is low, and also when one of EXT, RTC or RI goes high if ACPWR is true or LB is false. It is entered from DOZE or SLEEP when the activity monitor 16 detects activity with addresses in the predetermined address set. In the ON state encoded on lines 34, all power control outputs VP[0 . . . n] will be controlled by the PWRON register 57. Upon entering the ON state, the DOZE timeout timer 63 will be retrigged. The LCD and EL timeouts in timers 66 and 67 will be retrigged when entering the ON state from SUSPEND or OFF. The retrigger lines from STATE logic 23 to the timers are not shown in FIG. 3 for clarity.

In FIG. 3, the STATE logic 23 receives the CPU data bus D(0 . . . 7) from bus 5 for receiving state commands issued by the software monitor 80 of TABLE 2. The STATE logic also receives the address detection line 76 from activity monitor 16 which enables the STATE logic 23 to receive the state commands from the software monitor when addressed over the bus 5.

If the SLOW bit in the control register 53 is false, the CLKOUT rate on line 28 will be full speed. If the SLOW bit is true, CLKOUT will be as specified by the CCLK[0,1] bits in register 53. This clock control allows the user to save power, for example, when running non-computationally intensive applications such as word processing.

## DOZE State

The DOZE state is entered from the ON state when the activity monitor 16 has not detected activity and therefore has not provided the ACTIVITY signal within the time, T1, specified by the DOZE timer 63. In the DOZE state encoded on lines 34, the power control outputs VP[0 . . . 7] from unit 17 are controlled by the PWRDOZE register 58. If a non-static CPU 4 is used, the clock on line 28 will be slowed as specified by CCLK[0,1] in register 53.

If a static CPU 4 is used, CLKOUT on line 28 will stop in the low state immediately following a non-DMA memory read instruction, as indicated by \*S1 going high while \*AEN is low, so that no chip select will be low. If INTR goes high, CLKOUT will be enabled until after EOI is written to the

interrupt controller with INTR false. If INMI goes high, CLKOUT will be enabled. If an internally generated NMI occurs, CLKOUT will be enabled until the NMIMASK register 55 is read. If any DRQ goes high, CLKOUT will be enabled until after the next memory read instruction with AEN and all DRQ inputs false. The enable request functions for INTR, INMI, internal NMI and DMA are separate and CLKOUT is enabled when any event requests it, so that an interrupt handler in CPU 4 will run to completion even if it is interrupted by a DMA request. These enable request functions are independent of the activity monitor and the ACTMASK register 54. Enabling CLKOUT does not cause the PMU 15 to leave DOZE, unless the activity monitor 16 is subsequently triggered. If this trigger occurs, the PMU 15 will enter the ON state and the enable request logic will be cleared.

#### SLEEP State

The SLEEP state is entered when the PMU 15 has been in the DOZE state for the time, T2, specified by the SLEEP timer 64 and no ACTIVITY signal has occurred. In the SLEEP state, the CLKOUT operation is the same as in DOZE. The power control outputs are controlled by the PWRSLLEEP register 59.

Alternatively, the PMU can be programmed to generate NMI and remain in DOZE state instead of automatically entering SLEEP.

#### SUSPEND State

The SUSPEND state is entered when the PMU 15 has been in the SLEEP state for the time, T3, specified by the SUSPEND timer 65 or when a power check detects low battery signals, LB or LLB. The SUSPEND state is entered after these conditions only when the CPU 4 writes the code for SUSPEND to the STATUS register 40 and this operation requires software support because in SUSPEND the CPU operation is affected. In SUSPEND operation, CLKOUT is the same as CLKI. The power control outputs are controlled by the PWRXSUSPEND register 60. In SUSPEND, the CPU 4 and the device (for example, a switch) which generates the system reset signal must be powered off. Only activity on the EXT, RI or RTC inputs can cause an exit from SUSPEND, and the new state after exit will be ON. When the reset circuit power is restored, it will reset the CPU 4, which will then execute a warm startup routine in a conventional manner. DRAM refresh may be enabled in SUSPEND. If DRAM refresh is not enabled, the PMU 15 does not need OSC from unit 43 in SUSPEND, and gates it off internally to minimize OSC power consumption. The OSC output will stay low. The bus interface is inhibited, and the data bus 5 is tristated.

#### OFF State

The OFF state is entered when the CPU 4 writes the code of OFF (OFFh) to the STATUS register 51. It is also entered 5 seconds after the EXT input goes high if the NMI is not serviced.

The OFF state is meaningful only when the PMU 15 is powered from a battery while the rest of the computer 3 is turned off. This type of power connection is necessary only if the PMU 15 must awaken the system from the OFF state by activating VP outputs on lines 33 in response to transitions on the EXT input. If this function is not required, then the PMU 15 may be powered off when the system is powered off, and the OFF state as described below is not required.

In the OFF state, all outputs from the PMU 15 are either low or tristated, and all devices other than PMU 15 in the computer 3 are powered off. Any inputs will have pulldowns so that floating inputs, if any, will not cause increased power dissipation. Only activity on the EXT, RI or RTC inputs can cause an exit from OFF, and the new state will be ON. The bus 5 interface is inhibited and data bus 5 is tristated.

#### Activity Monitor

The activity monitor 16 includes an address detector 73 which receives addresses from bus 5 representing the address activity of the CPU 4. The address detector 73 receives, for example, control lines and address lines SA(0 . . . 9) from bus 5 for sensing when those addresses are within the predetermined address set. The predetermined address set is defined, for example, by an address set specified by ACTMASK register 54. The detector 73 compares or masks the address set specified by register 74 with the addresses on bus 5 and provides an address detect signal on line 76 to the logic 77. The logic 77 receives the other inputs to the activity monitor 16 and combines them, using conventional logic circuitry, to provide three outputs.

The three outputs provided by activity monitor 16 are produced by conventional logic or by software as shown in TABLE 1. The EXTRIG output is a function of keyboard activity only and is used to retrigger the EL backlight timer 67. The LCDTRIG output is true for keyboard activity or video memory writes, and retriggers the LCD timer 66. The ACTIVITY output is an OR function of a programmable selection of different activities specified in the ACTMASK register 54. When active, this output returns the PMU 15 to the ON state and retriggers the DOZE timeout timer 63. The activity monitor 16 does not produce the ACTIVITY output in response to accesses to the registers of PMU 15.

#### OSC Programmability

The OSC frequency of refresh control unit 20 provides the timebase for the timers and the refresh for DRAM memory 11. The PMU 15 may be programmed to accept a range of OSC frequencies. The OSC frequency of oscillator 43 is fed to a counter 44 which divides it by a divisor which is programmed in the OSC register 56. The programmable counter output of divider 44 is divided to produce 256 Hz which is used by the refresh control logic 48. Further dividing in divider 46 produces 32 Hz for slow refresh to refresh control logic 48, and 8 Hz and 1/(7.5) Hz for use by the timers 63, 64, 65 and 68.

#### Timers

There are six timers in the PMU 15, namely, DOZE timer 63, SLEEP timer 64, LB (low battery) timer 68, SUSPEND timer 65, EL (backlight) timer 66, and LCD timer 67. Each of the six timers a 4-bit register loadable by CPU 4 over bus 5. Setting a timer register to 0 disables it; setting it to a nonzero value enables it. If enabled, certain timers are triggered by the transition to the ON state. Individual timers are also triggered by events specific to their functions. Some timers are retriggerable, timing out at a programmable time following the last trigger.

The DOZE timer 63 is programmable from 1 to 15 seconds with a resolution of 1 second, and the SUSPEND timer 65 is programmable from 5 to 75 minutes with a resolution of 5 minutes. All other timers are programmable from 1 to 15 minutes with a resolution of one minute. There is a quantization error associated with retriggering any timer. This error is a quantization error associated with retriggering



any timer. This error will cause the actual timeout to be up to  $\frac{1}{8}$  of the resolution of the timer longer (but never shorter) than the programmed value. The error does not vary with the programmed value.

The LCD timer **66** and the EL timer **67** are retriggerable. The timer outputs are AND'ed in AND gates **41** and **42** with the power control bits selected by the power control multiplexer **76** according to the current PMU state to control the LCD (VP0) and EL (VP1) power control outputs to EXOR **35**. This operation provides the flexibility to turn the EL and LCD outputs off when the associated timers **66** and **67** time out, or to control the outputs in any PMU power-management state under control of multiplexer **76**.

The DOZE timer **63** is retriggerable and is triggered by the activity monitor ACTIVITY output in the ON state, and triggers the transition to DOZE state when it times out.

The SLEEP timer **64** is triggered when the DOZE state is entered and is cleared when the DOZE state is exited. Timer **64** either generates NMI or triggers the transition to SLEEP state when it times out.

The SUSPEND timer **65** is triggered when the SLEEP state is entered and is cleared when SLEEP is exited. If unmasked, an NMI will be generated when it times out.

The LB timer **68** is enabled when ACPWR is false (no AC power). Timer **68** is triggered when LB is first detected. If unmasked, NMI is generated by the LB timer **68** output once per minute when it times out, until a period of one minute elapses during which LB remains continuously false. The NMI cause will be identified as an LB or LLB interrupt. Software can maintain a counter and display a message once per X interrupts. It can also monitor LLB and shut the computer down after Y interrupts. It can also monitor LLB and shut the computer down after Y interrupts with LLB true.

#### NMI

The PMU unit **15** OR's together a number of internally generated NMI requests to produce the NMI output on line **27**. These requests can be masked by bits in the NMIMASK register **55**. The INMI input comes from conventional external NMI-generating logic such as a parity detector, and can be OR'ed with the internal NMI requests to generate NMI when unmasked by the OS2 bit in the NMIMASK register **55**. The NMI output on line **27** generally goes to the CPU NMI input, except on OS2 systems where it must go to an IRQ. The NMI CAUSE code bits in the Status register **40** indicate the cause of the NMI on line **27**. An internally generated NMI is cleared by reading the NMIMASK register **55**.

NMI may be generated to indicate a low battery when ACPWR is false.

If the MSKSLEEP bit is cleared, the PMU **15** will generate NMI when the SLEEP timer **64** times out and remain in DOZE instead of entering SLEEP.

NMI is also generated when the SUSPEND timer **65** times out. Software can then save status and go to SUSPEND or OFF state.

A high on the EXT input while not in the OFF or SUSPEND state will generate NMI. Software can then save status and go to SUSPEND or OFF state. If the NMI is not serviced within 5 seconds, the PMU **15** assumes there is no software support for SUSPEND and will turn all power off and enter the OFF state.

#### Refresh In SUSPEND State

Refresh is enabled by setting the RASWIDTH[0 . . . 1] bits in the OSC register **56** to a nonzero value. This enables

OSC to run in SUSPEND mode, and the RASWIDTH value also sets the width of the \*RAS pulse in units of OSC clock periods. Slow refresh is enabled by setting SLWREF high. The PMU **15** generates \*MRAS and \*MCAS signals to mux **32** to refresh DRAM while the CPU is powered off or being reset. When the CPU is active, the \*PCRAS, \*PCCAS signals on lines **30** from the PC controller **13** are selected by multiplexer **30** to provide the \*RAS, \*CAS signals on lines **29**. \*REFRSEL on line **72** will go low to indicate that the PMU **15** is controlling refresh and high for PC controller **13** control.

If enabled, the DRAM refresh outputs are active in SUSPEND. When entering SUSPEND, the PMU **15** immediately generates a burst of 1024 CAS before RAS refresh cycles. A burst of 256 cycles is then repeated every 3.9 ms if SLOWREF is false or every 31.25 ms if SLOWREF is true. After entering the ON state from SUSPEND, the PMU **15** generates bursts of 1024 refresh cycles over 2.9 ms. This operation allows as much time as needed for CPU power stabilization, crystal oscillator startup and CPU reset. When the CPU is ready to take over control of the DRAM, it must poll the SUPPLY register **38** until the DRAMRDY bit goes high. The PMU **15** senses the polling operation as a request from the CPU for DRAM control, and at the end of the first refresh burst following a CPU I/O read of the SUPPLY register **38**, the PMU **15** sets \*REFRSEL high to return control of the DRAM to the CPU. The DRAMRDY bit is essentially the same signal as \*REFRSEL.

The purpose of the bursts when entering and leaving SUSPEND is to eliminate violations of the refresh rate spec when switching between external refresh row address generation (DMA cycles during ON) and internal row address generation (CAS before RAS during SUSPEND).

Pseudostatic RAM refresh is also supported. When \*REFRSEL goes low, \*RAS can drive \*RFSH low for auto refresh mode. The burst refresh will assure that switching between external and internal refresh will not violate the refresh rate spec. Self refresh can also be used by driving \*RFSH low when \*REFRSEL is low, but other logic will have to generate the refresh burst when entering and leaving SUSPEND, if required.

#### External Wakeup Inputs

RI is a rising edge sensitive input, to state logic **23** from a modem ring indicator RI output of a peripheral **7**. The number of rising edges required for this input to be recognized is specified in bits D[4 . . . 6] of the Control register **53**. The default is one transition. If these bits are zero, this input is disabled. If enabled, a rising transition on this input will force the PMU **15** to the ON state.

RTC is an edge sensitive wakeup-alarm input from a real time clock in CPU clock control **49** of FIG. 3. A rising or falling transition on this input will force the PMU **15** to the ON state.

EXT is a rising edge sensitive input, intended for use with an external pushbutton. A rising transition on this input while the PMU **15** is in OFF or SUSPEND will force the PMU **15** to the ON state. A transition in ON, DOZE or SLEEP will generate NMI.

EXT is debounced in ON, DOZE and SLEEP in a conventional debouncer circuit **36**. A rising edge immediately generates NMI but only if EXT has been sampled low at least twice by a 32 Hz debounce clock from counter **46** prior to the rising edge. The debounce clock is derived from OSC **43** and therefore may be stopped in SUSPEND and OFF, so the PMU **15** will not enter these states until the

## 21

debounce operation is completed. To prevent resuming due to contact bounce on the release of a pushbutton, the PMU 15 will defer execution of a change of state command from the CPU 4 until after the EXT input has been sampled low twice by the debounce circuit 36. This operation is typically transparent to software. For example, if the user presses the button in ON, the PMU 15 will generate NMI, and the CPU will write the command to enter SUSPEND and then execute a halt instruction. Nothing will happen until after the pushbutton is released, at which time the PMU 15 will enter SUSPEND.

## Resume and Power On

The PMU 15 has its own private \*RESET signal, typically from an external RC network detector 71 which detects VCC. This signal resets only the PMU 15 when power, VCC, is first applied to it. A separate reset signal must be generated by external hardware for the CPU when entering the ON state from SUSPEND or OFF state. At power on, the CPU 4 must read the RESUME bit in the Status register 51. RESUME will be cleared if the startup is a cold start from OFF and will be set to indicate a warm start (resume) from SUSPEND. If RESUME is cleared, the wakeup bits WU[0 . . . 1] in the Status register 51 will be zero, otherwise they will indicate which external input caused the resume. The RESUME bit will be cleared after the Status register is read.

## Clock Switching

The clock switch control 69 is provided to switch input clocks CLK1IN and CLK2IN clocks to output clocks

## 22

CLK1OUT AND CLK2OUT for peripherals. The CLK1 and CLK2 operations are the same. For example, the CLK1IN is passed to the CLK1OUT output by control 69 in ON and DOZE. When entering SLEEP mode, CLK1OUT will stop synchronously in the low state. CLK1OUT will start synchronously when returning to the ON state.

## Low Battery Detection

The LB and LLB inputs indicate low battery and low low battery as generated by a conventional battery level detector in power supply 9 of FIG. 1. The polarity of these inputs is programmable by the LBPOL line which can be strapped low or high. If this line is high, LB and LLB are high true. If low, these inputs are low true. The status of the LB and LLB lines after polarity correction can be read in the SUPPLY register 38. A low battery indication can generate NMI.

## Power Sequencing

To minimize turnon transients, the turnon of VPI (EL power) is delayed by 4 to 8 ms after OSC begins clocking, when entering the ON state.

## Program Listing

A computer program embodiment of the hardware monitor for the power management unit appears in the following TABLE 1.

TABLE 1

```

=====
; Power Management Software
=====
;
; Copyright - 1989 Vadem, Inc.
;
; All Rights Reserved.
;
; C:
=====

.xlist
include romeq.dec
include romdef.dec
include seteq.dec
include clkeq.dec
include 8250eq.dec
include prneq.dec
include crteq.dec
include vg600.dec
include notes.dec
include kbdeq.dec
.list
include pwreq.dec

MSG <Power Management BIOS Kernel>

pmdata segment para public 'pmdata'
extrn on_power_status:word
extrn sleep_power_status:word
extrn lb_event_handler:dword
extrn lb_event_mask:word
extrn doze_timeout:byte
extrn doze_count:byte
extrn sleep_timeout:byte
extrn sleep_count:byte
extrn kbd_timeout:byte
extrn kbd_count:byte
extrn pwr_off_timeout:word
extrn pwr_off_count:word
extrn led_time_on:byte
extrn led_time_off:byte
extrn led_next_event:byte
extrn led_cycle_count:word
extrn lb_def_event_type:byte
extrn lb_event_rep:byte
extrn lb_event_count:byte
extrn sleep_save_buf:byte
extrn pm_flags:byte
extrn second_counter:byte

```

TABLE 1

```

extrn  minute_counter:byte
extrn  one_shot_handler:dword
extrn  one_shot_timer:dword
extrn  lb_last_event:word
extrn  pm_ram_chksum:word
extrn  pm_save_ss:word
extrn  pm_save_sp:word
extrn  pm_resume_stack:byte
pmdata ends

data0  segment public 'DATA0'
extrn  crt_addr:word
extrn  reset_flag:word
data0  ends

code   segment word public 'code'
assume cs:code, ds:pmdata

public power_management
, power_management_init, power_management_enable
public pm_timer_hook, pm_kbd_hook
public pm_enter_sleep, read_com, write_com
public write_crt_reg, read_crt_reg
public suspend, resume

extrn  data0p:word
extrn  get_pm_ds:near
extrn  alloc_pm_ds:near
extrn  default_low_battery_alarm:near
extrn  rd_rtcw:near
extrn  wr_rtcw:near
extrn  rd_rtcb:near
extrn  wr_rtcb:near
extrn  play_song:near
extrn  set_ibm_timer:near
extrn  checksum:near

extrn  oem_pm_init:near
extrn  oem_pm_get_status:near
extrn  oem_pm_extensions:near
extrn  oem_pm_halt:near
extrn  oem_pm_activity?:near
extrn  oem_pm_reset_activity:near
extrn  oem_pm_toggle_led:near
extrn  oem_pm_turn_on_peripherals:near
extrn  oem_pm_turn_off_peripherals:near
extrn  oem_pm_power_off:near
extrn  oem_pm_suspend:near
extrn  oem_pm_blank_video:near

```

TABLE 1

```

extrn oem_pm_restore_video:near
extrn oem_pm_save_peripherals:near
extrn oem_pm_restore_peripherals:near
extrn oem_pm_save_video_state:near
extrn oem_pm_restore_video_state:near
extrn oem_pm_kbd_activity?:near
extrn oem_pm_reset_kbd_activity:near
extrn oem_pm_make_power_off_noise:near
extrn oem_pm_make_low_battery_noise:near
extrn oem_pm_defaults:near
extrn oem_pm_get_hw:near
extrn oem_pm_get_nmi_handler:near

```

```

es_arg equ word ptr [bp+16]
ah_arg equ byte ptr [bp+15]
al_arg equ byte ptr [bp+14]
ax_arg equ word ptr [bp+14]
cx_arg equ word ptr [bp+12]
cl_arg equ byte ptr [bp+12]
ch_arg equ byte ptr [bp+13]
dx_arg equ word ptr [bp+10]
dl_arg equ byte ptr [bp+10]
dh_arg equ byte ptr [bp+11]
bh_arg equ byte ptr [bp+09]
bl_arg equ byte ptr [bp+08]
bx_arg equ word ptr [bp+08]
bp_arg equ word ptr [bp+04]
si_arg equ word ptr [bp+02]
di_arg equ word ptr [bp+00]

```

page

```

pwrnrgt_fx_table label word
dw pm_get_profile ;get current profile
dw pm_get_rtc_profile ;get profile in rtc
dw pm_set_profile ;set active profile
dw pm_set_rtc_profile ;update rtc profile
dw pm_event_handler ;install evt handler
dw pm_one_shot_event_handler ;install evt handler
dw pm_get_pm_status ;get status
dw pm_enter_sleep ;enter sleep
dw oem_pm_power_off ;power off
dw oem_pm_suspend ;suspend
pwrnrgt_fx_table_len equ ($-pwrnrgt_fx_table)/2

```

```

;=====
; power_management_init
;=====
;

```

TABLE 1

```

; Called to initialize the Data Structures for
; the power management kernel. Allocate a Data Segment
; initialize variables, install the default
; Low Battery event handler, and call oem_pm_defaults
; to setup any system specific hardware or default
; settings. Does not enable the power management yet...

power_management_init proc
dbMESSAGE fTEST8+fTESTb <power_management_init>
call alloc_pm_ds ;now sets ds...

sub ax, ax
mov pm_flags, al
mov second_counter, 18
mov minute_counter, 60 ;init this stuff...

mov ax, (SYS_PWR_MGT shl 8) or GET_RTC_PWR_PROFILE
int TASKINT

push dx ;save power off timeout
mov ax, (SYS_PWR_MGT shl 8) or SET_PWR_PROFILE
int TASKINT

mov ah, CM_ALM_REP ;get alarm repeat
call rd_rtcb
mov cl, al ;input param

mov ah, CM_DEF_ALM
call rd_rtcb
mov bl, al
and bx, LBE_LB1 or LBE_LB2 ;default event type...

pop dx ;restore pwr_off_timeout

mov ax, (SYS_PWR_MGT shl 8) or INSTALL_LP_EVT_HANDLER
push cs
pop es
mov di, offset default_low_battery_alarm
int TASKINT

jmp oem_pm_defaults

power_management_init endp

;=====
; Start Power Management...
;=====
;

```

TABLE 1

```

; After Initial Power Up Self Tests are completed,
; power management is enabled. Do not enable until
; it is time to boot the system.
;
;
power_management_enable proc
    push ds
    call get_pm_ds      ;load ds pointer
    or   pm_flags, PM_ENABLED
    pop  ds
    ret
power_management_enable endp

;=====
; Power Management dispatch routine
;=====
;
; Programmatic interface to the Power Management Kernel.
; used to read /alter management parameters.
;
; This function is installed as Int 15h (task management)
; function 0CFh.

Power_Management proc near
    sti
    cmp al, PM_OEM_FX      ;extended function??
    jnz @F                ;no...
    jmp oem_pm_extensions ;do private functions

@@:    cmp al,pwrmtg_fx_table_len
    jae md_err            ;not here

    push ds
    push es
    pusha
    mov bp,sp             ;stack addressing...
    call get_pm_ds       ;load ds pointer
    sub ah,ah
    shl ax,1
    mov si,ax
    call pwrmtg_fx_table[si] ;execute the function
    popa
    pop es
    pop ds
    retf 2                ;return

md_err: mov ah,86h       ;fx err
        stc
        retf 2          ;save flags
Power_Management endp

```

TABLE 1

```

page
;=====
; pm_get_profile
;=====
;
; Return to caller the current active profile.
; This may have been modified by Set profile calls.
;
pm_get_profile:
    dbMESSAGE fTEST8+fTESTb <pm_get_profile>
    mov ax,on_power_status
    mov si_arg, ax

    mov ax,sleep_power_status
    mov di_arg, ax

    mov al,lb_def_event_type
    mov bl_arg, al

    mov al,kbd_timeout
    mov bh_arg, al

    mov al,doze_timeout
    mov cl_arg, al

    mov al,sleep_timeout
    mov ch_arg, al

    mov ax,pwr_off_timeout
    mov dx_arg, ax
    cld
    ret

;=====
; pm_set_profile
;=====
;
; Set the current active profile.
; Alter the desired parameters. Do this by calling
; get profile, and then changing just those parameters
; and then calling set profile

pm_set_profile:
    dbMESSAGE fTEST8+fTESTb <pm_set_profile>

    mov doze_timeout, cl
    mov sleep_timeout, ch
    mov lb_def_event_type, bl
    mov kbd_timeout, bh
    mov pwr_off_timeout, dx

```



TABLE 1

```

mov  pwr_off_count,0                ;clear countdown

mov  ax, si_arg
mov  on_power_status, ax

mov  ax, di_arg
mov  sleep_power_status, ax

mov  ax, si_arg
call oem_pm_turn_on_peripherals
clc
ret

```

page

```

;=====
; pm_get_rtc_profile
;=====
;
; Read Back current profile stored in the NV-RAM.
; This profile is the default active at power up
;
pm_get_rtc_profile:
dbMESSAGE fTEST8+fTESTb <pm_get_rtc_profile>

mov  ah,CM_OPCW
call rd_rtow
mov  si_arg, bx

mov  ah,CM_SPCW
call rd_rtow
mov  di_arg, bx

mov  ah,CM_DOZE
call rd_rtow
mov  cx_arg, bx

mov  ah,CM_ALM_REP
call rd_rtow
mov  dx_arg, bx

mov  ah,CM_DEF_ALM
call rd_rtow
mov  bx_arg, bx

clc
ret

;=====
; pm_set_rtc_profile
;=====

```

TABLE 1

```

;
; Set the current NV-RAM profile.
; Alter the desired parameters. Do this by calling
; get rtc profile, and then changing just those parameters
; and then calling set rtc profile
; This profile will be active next hard reset...

pm_set_rtc_profile:
    dbMESSAGE fTEST8+fTESTb <pm_set_rtc_profile>
    mov ah, CM_OPCW
    mov bx, si_arg
    call wr_rtcw

    mov ah, CM_SPCW
    mov bx, di_arg
    call wr_rtcw

    mov ah, CM_DOZE
    mov bx, cx_arg
    call wr_rtcw

    mov ah, CM_ALM_REP
    mov bx, dx_arg
    call wr_rtcw

    mov ah, CM_DEF_ALM
    mov bx, bx_arg
    call wr_rtcw

    cll
    ret

page
;=====
; pm_event_handler
;=====
;
; Install a Low Battery Event Handler.
; Specify the Event criteria, which dictates
; under which conditions the Event Handler is called,
; and specify a repeat rate for recurring conditions.
; Also specify a power off/ Suspend timeout
; after the detection of a Low, Low Battery condition

pm_event_handler:
    dbMESSAGE fTEST8+fTESTb <pm_event_handler>

    xchg [lb_event_mask],bx
    mov bx_arg, bx

```

TABLE 1

```

xchg word ptr [lb_event_handler],di
mov di_arg, di

mov bx,es_arg
xchg word ptr [lb_event_handler+2],bx
mov es_arg, bx

xchg [lb_event_rep], cl
mov cl_arg, cl

xchg [pwr_off_timeout], dx
mov dx_arg, dx

and [pm_flags],not PM_LB_HANDLER
mov ax, word ptr [lb_event_handler]
or ax, word ptr [lb_event_handler+2]
jz @F
or [pm_flags],PM_LB_HANDLER

@@: mov [lb_event_count], 0 ;time to do...
    clc
    ret

;=====
; pm_one_shot_event_handler
;=====
;
; Certain applications and/or management functions
; may wish to be notified if a timeout period occurs
; after a certain event. This function provides
; a 55 Msec resolution timing function for timing
; events, and acts like a hardware one-shot; timing out
; calling the one shot handler, and cancelling the
; timer until it is reloaded again.

pm_one_shot_event_handler:
    dbMESSAGE fTEST8+fTESTb <pm_one_shot_handler>

    mov word ptr [one_shot_handler],di
    mov bx,es_arg
    mov word ptr [one_shot_handler+2],bx

    mov word ptr [one_shot_timer], cx
    mov word ptr [one_shot_timer+2], dx

    mov al, [pm_flags] ;get status
    or cx, dx ;cancel??
    jz os_cancel ;yes...

```

## TABLE 1

```

;==== Not a Cancel request, so check if one shot is rolling

test al, PM_ONE_SHOT_HANDLER
jnz os_err

and al, not PM_ONE_SHOT_HANDLER

mov bx, word ptr [one_shot_handler]
or bx, word ptr [one_shot_handler+2]
jz @F
or al, PM_ONE_SHOT_HANDLER

@@: mov [pm_flags], al
    clc
    ret

os_err: mov ah_arg, 86h                ;already active
        stc
        ret

os_cancel:
        and al, not PM_ONE_SHOT_HANDLER
        mov [pm_flags], al
        clc
        ret

;=====
; pm_get_pm_status
;=====
;
; Return the status of the System Status port.
; this port has two defined bits:
;
; bit 0 = Low Battery
; bit 1 = Low, Low Battery
;
; Other bits have OEM specific meanings

pm_get_pm_status:
    dbMESSAGE fTEST8+fTESTb <pm_get_pm_status>
    call oem_pm_get_status
    mov bx_arg, ax
    ret

;=====
; pm_enter_sleep
;=====
;
; This function sets up a sleep command at the

```

TABLE 1

```

; next timer interrupt.
;
pm_enter_sleep:
  or pm_flags, PM_SLEEP          ;say to sleep
  ret

assume cs:code,ds:data0,es:pmdata

;=====
; read_crt_reg
;=====
;
; This routine is used to read the state of a
; video register
;
; inputs:  bl          = address in 6845
;
; outputs: ax          = word read
;=====
read_crt_reg proc near
  mov dx,crt_addr                ;set addr
  mov al,bl
  out dx,al
  inc dl
  in al,dx
  mov ch,al                      ;get msb
  dec dl
  mov al,bl                      ;set next addr
  inc al
  out dx,al
  inc dl
  in al,dx
  mov ah,ch                      ;get lsb
  ret
read_crt_reg endp

;=====
; read_com
;=====
;
; This routine is used to read the status of a
; 8250 serial port and save it in memory

read_com      proc                ;save com port in DX

  add dl,1cr
  in al,dx
  or al,DLAB                ;set dlab to read div reg

```

TABLE 1

```

jmp $+2
out dx,al
sub dl,1cr
in ax,dx ;read divisor reg
stosw

add dl,1cr
in al,dx
and al,not DLAB
jmp $+2
out dx,al
sub dl,1cr-ier

mov cx,6
rcom1: in al,dx
inc dx
stosb
loop rcom1
ret
read_com endp

;=====
; read_lpt
;=====
;
; This routine is used to read the status of a
; Industry Standard Parallel port and save it in memory

read_lpt proc
add dl,printer_control
in al,dx
stosb
ret
read_lpt endp

assume cs:code,ds:pmdata,es:data0

;=====
; write_com
;=====
;
; This routine is used to restore the status of a
; 8250 serial port from where it was saved in memory

write_com proc
add dl,1cr
in al,dx
or al,DLAB
jmp $+2
out dx,al

```

TABLE 1

```

sub  dl, lcr
lodsw
out  dx, ax

add  dl, lcr
in   al, dx
and  al, not DLAB
jmp  $+2
out  dx, al
sub  dl, lcr-ier

mov  cx, 6
wcom1: lodsb

out  dx, al
inc  dx
loop wcom1
ret
write_com  endp

;=====
; write_lpt
;=====
;
; This routine is used to restore the status of a
; Industry Standard Parallel port from
; where it was saved in memory

write_lpt  proc
add  dl, printer_control
lodsb
out  dx, al
ret
write_lpt  endp

;=====
; write crt register
;
; This routine is used to restore the status of a
; video register from memory
;
; inputs:  cx      = word to write
;          bl      = address in 6845
;=====
write_crt_reg proc near
mov  dx, crt_addr          ;set addr
mov  al, bl
out  dx, al
mov  al, ch                ;send msb

```

## TABLE 1

```

inc dl
out dx,al
dec dl
mov al,bl ;set next addr
inc al
out dx,al
inc dl
mov al,cl ;send lsb
out dx,al
ret
write_crt_reg endp

assume cs:code,ds:pmdata,es:nothing

page

;=====
; pm_kbd_hook
;=====
;
; In Software Based Power Management, this routine
; is part of the Keyboard Interrupt chain. It is
; used to detect keyboard activity.
;
; Called every KBD INT: Set Keyboard Active bit
;
; restore video if necessary
;
; must save regs, take care of ints...
;
;
pm_kbd_hook:
  dbPC fTEST1+fTESTb "k"
  call get_pm_ds ;get ds
  test pm_flags, PM_VBLANK ;video blanked out???
  jz @F ;NO

  call oem_pm_restore_video ;turn on screen
  and pm_flags, not PM_VBLANK ;clear blank flag

@@: or pm_flags, PM_KBDACT ;say keyboard had
activity
ret

page

;=====
; pm_timer_hook
;=====
;

```



TABLE 1

```

; In Software Based Power Management, this routine
; performs the function of the Timer and Dispatcher
; It is part of the Timer Interrupt chain, after
; the timer end of interrupt (EOI) has been sent.
;
; Checks for system activity and DOZEs/ SLEEPS
;
; Entry conditions: cli, ds,es,pusha saved, ds=data0p
;
; This routine contains two threads of code,
; which execute independently.
;
; COUNTER thread:
; -----
;
; The COUNTER thread checks for the one shot,
; handles the second and minute counters, and looks
; at the low battery level, and dispatches the LB
; event handler. It then looks at the DOZE flag,
; and if doze is active, returns without changing
; the activity status; so that the code after the DOZE
; HLT can function.
;
; DOZE thread:
; -----
;
; The DOZE thread runs when an activity check
; shows no activity has been present for the
; entire DOZE timeout. The processor clock
; is slowed, the DOZE bit is set, interrupts
; are enabled, and the CPU is put into HLT.
; When HLT is exited, (18.2 hz) the activity
; status is checked, to see if DOZE should be
; terminated. If activity is present,
; the DOZE flag is cleared and the
; activity exit is taken.
;
; If activity is not present, a test is made
; for the SLEEP timeout. If the SLEEP timeout
; has elapsed, SLEEP is entered, after saving
; the peripheral state. Otherwise, the CPU
; is halted, and the DOZE loop is reentered,
; and the cycle continues until
; terminated by ACTIVITY or SLEEP.
;
;=====
even                                     ;fast...

```

TABLE 1

```

pm_timer_hook:
    cli                                     ;ints are off...
    call get_pm_ds                          ;establish ds

    test pm_flags, PM_ENABLED               ;running yet??
    jnz @F
    jmp exit_wo_change                       ;no...

@@:    call oem_pm_get_hw                    ;get hw_caps to
ES:DI

    test pm_flags, PM_ONE_SHOT_HANDLER      ;have one??
    jz ck_sec                               ;no...

    dec word ptr one_shot_timer
    sbb word ptr one_shot_timer,0
    jnz ck_sec

    and pm_flags, not PM_ONE_SHOT_HANDLER  ;dont any more...
    call one_shot_handler                    ;called w/ ints disabled

;=====
; First, handle the one second dispatching
;=====

    even
ck_sec:
    dec second_counter
    jz is_sec
    jmp exit_wo_change

;=====
; Second Rolled, Check Minutes
;=====

is_sec: mov second_counter,18               ;ticks per second...reset

    dbPC fTEST2+fTESTb "~Q"
    dec minute_counter                       ;count minutes...
    jz @f
    jmp not_minute

@@:    dbPC fTEST2+fTESTb "("

page
;=====
; All Code Below is executed once per Minute.

```

## TABLE 1

```

; All Minute Counters are decremented here...
;=====
mov minute_counter, 60 ;reset

;=====
; Count Down Sleep Timer
;=====
;
; Turned On by Entering Doze...

sub ax, ax ;for resetting
cmp sleep_timeout,al ;timeout used??
jz lb_dec ;NO
mov al, sleep_count ;get sleep counter
test al,al
jz @F
dec al ;dec sleep counter
@@: mov sleep_count, al ;reset

;=====
; Count Down low battery event Timer
;=====
;
; Rep count set by LB event detection

lb_dec:
cmp lb_event_rep,ah ;timeout used??
jz kbd_dec ;NO
mov al, lb_event_count ;dec event counter
test al, al ;already 0???
jz @F ;yes..
dec al ;dec rep counter
@@: mov lb_event_count, al ;reset

;=====
; Check For Keyboard Activity
;=====
even
kbd_dec:
test es:[di].HW_CAPS, HWC_KBACT
jz pwr_dec ;doesnt support KB activity

call oem_pm_kbd_activity? ;kbd active??
jnz nokbact ;yes, normal

dbPC fTEST2+fTESTb "~Y"

```

## TABLE 1

```

;=====
; Count Down Keyboard Timer
;=====
;
; Turned On by No Kbd Activity...

    cmp kbd_timeout,0           ;timeout used??
    jz  pwr_dec                 ;NO

    mov al, kbd_count           ;get blank counter
    test al,al                 ;done...
    jz  pwr_dec

    dec al                      ;dec sleep counter
    mov kbd_count, al          ;reset to 0
    jnz pwr_dec                ;next counter

    or pm_flags, PM_VBLANK     ;say its off...
    call oem_pm_blank_video    ;blank the video
    jmp short pwr_dec

nokbact:
    mov al,kbd_timeout         ;reset counter
    mov kbd_count, al
    call oem_pm_reset_kbd_activity ;clear activity bit

;=====
; Count Down Power Off Timer
;=====
;
; Turned On by LB2 detection below, and powers off
; if hw supports it
;

    even
pwr_dec:
    test es:[di].HW_CAPS, HWC_POWER ;doesnt support power off
    jz  not_po

    cmp pwr_off_timeout,0      ;Countdown enabled??
    jz  not_po                 ;NO
    dec pwr_off_count          ;dec event counter
    jnz not_po

    dbPC fTEST2+fTESTb "p"
    call oem_pm_power_off

not_po:
    dbPC fTEST2+fTESTb ')'

```

## TABLE 1

```

page
;=====
; All Code Below is execute once a Second
;=====

    even
not_minute:

;=====
; Check and attend to the low battery indicators...
;=====
;
; Once a Second, we check the Battery Levels via
; polling. Since some hardware generates an NMI,
; we may not need to do this, Since the NMI will
; be invoked at event time.
;
; The Event Handler is assumed not to be re-entrant,
; so it will not be re-entered until the first event
; is handled. The next event will trigger as soon as
; the PM_IN_LB_HANDLER flag is cleared.
;
; Handler or no, the power off/Suspend Timeout is started
; at Low, Low Battery detection.

    test es:[di].HW_CAPS, HWC_LB_NMI
    jnz ck_led ;supports nmi, dont need this

    call oem_pm_get_status ;get this stuff
    and ax, lb_event_mask ;need to attend to??
    jz ck_lb ;no...

    test pm_flags, PM_LB_HANDLER ;have one??
    jnz ck_ilbh ;yes...

ck_lb: mov lb_event_count, 0 ;clear rep count for re-
entry...
ck_lba: test ax, LBE_LB2 ;need to start power
off??
    jz ck_led ;no...
    jmp short pwr_ct ;still count power off

ck_ilbh:
    dbPC fTEST2+fTESTb "v"

    test pm_flags, PM_IN_LB_HANDLER ;Blocked??
    jnz ck_lb2 ;dont reenter

```

## TABLE 1

```

cmp ax, lb_last_event      ;same event as previously??
jnz ck_fevt

cmp lb_event_count,0      ;time to repeat??
jnz ck_lb2                ;no...

even
ck_fevt:

mov lb_last_event,ax      ;save event
or pm_flags, PM_IN_LB_HANDLER
mov bl,lb_def_event_type ;default criteria
push ax
call lb_event_handler    ;do it, LB flags in
ax...
pop ax
mov bl, lb_event_rep      ;reset
mov lb_event_count, bl   ;event rep time
and pm_flags, not PM_IN_LB_HANDLER

;=====
; Start power off timeout/suspend machine
;=====

ck_lb2: test ax, LBE_LB2      ;need to start power
off??
jz ck_led                ;no...
cmp pwr_off_count,0      ;started previously??
jnz ck_led                ;yes...

pwr_ct: mov ax, pwr_off_timeout ;start event
test ax,ax               ;immediate off/suspend???

jnz pwr_to                ;no...
test es:[di].HW_CAPS, HWC_SUSPEND
jz ck_led                 ;doesnt support suspend

dbPC fTEST2+fTESTb "o"
call suspend              ;suspend the machine...
jmp exit_w_activity       ;yes, run now...

pwr_to: mov pwr_off_count, ax ;counter

;=====
; Handle LED Flash Cycles
;=====
;
; Some OEMs flash LEDs at different duty cycles to
; indicate different operational conditions.
;

```

## TABLE 1

```

; On/Off modulation is provided by this function.
;
; LED flash cycles are handled
; during the once per second loop
;

even
ck_led:
    test es:[di].HW_CAPS, HWC_LEDS
    jz ck_activity ;doesnt support LEDs

    cmp led_time_on, 0 ;LED cycle active??
    jz ck_activity ;no

    dec led_next_event ;dec counter to next
delta
    jnz ck_activity ;Non-zero, wait

;=== LED event time, toggle state, inc counters

    call oem_pm_toggle_led

    mov al, led_time_off ;NO
    jz ck_led2

    mov ax, led_cycle_count ;count infinite...
    test ax, ax ;yes...
    jz ck_led1

    dec ax
    mov led_cycle_count, ax ;dec count every ON...
    jnz ck_led1 ;not timed out yet...
    mov led_time_on, 0 ;LED cycle NOT active

ck_led1:
    mov al, led_time_on

ck_led2:
    mov led_next_event, al ;reset

;=====
; Next, check if reentering from DOZE timer int
;=====
;
; Thread detection logic:
; we made it to here, so lets see if we need to
; exit to block again in DOZE, or to process a sleep
; command, or perhaps enter doze.
;
; If the DOZE flag is set, this means we entered the
; timer hook from doze. we should then exit without

```

TABLE 1

```

; resetting the activity monitor, and let the DOZE thread
; see if something happened to run Full Clock speed.
;
; If the DOZE flag is not set, check and see if No activity
; has been present for the DOZE timeout, and enter DOZE if so.
; Otherwise reset the activity monitor.

even
ck_activity:

    test pm_flags, PM_SLEEP           ;Req to sleep??
    jz   @F                           ;no
    call sleep                        ;yes...
    call oem_pm_halt                  ;run...
    jmp  wake

@@:   test pm_flags, PM_DOZE           ;Were WE dozing...
    jz   @F                           ;no
    jmp  exit_wo_change               ;YES, exit to code below

;=== Next, check the activity Monitor ===

@@:   dbPC fTEST2+fTESTb "I"
    call oem_pm_activity?            ;turns ints off...
    jnz  exit_w_activity             ;yes, normal

    cmp  doze_timeout, 0             ;doze allowed??
    jz   @F                           ;NO
    dec  doze_count                  ;timeout??
    jnz  @F
    jmp  go_doze
@@:   sti
    jmp  exit_wo_change

;=====
; exits...
;=====
;
; Various exits to the COUNTER and DOZE threads...
;
; Depending on Activity conditions

even
exit_w_activity:

;=== Exit, and reset the activity monitor
sti

```



TABLE 1

```

mov al, doze_timeout
mov doze_count, al

;=== Exit, and reset the activity monitor

exit_w_clear:
    dbPC fTEST2+fTESTb "~p"
    call oem_pm_reset_activity
exit_wo_change:
    ret

page
;=====
; go_doze
;=====
;
; At this point, we enter DOZE, having fulfilled the
; criteria to enter that STATE
;
even
go_doze:
    mov al, sleep_timeout          ;start sleep counter
    mov sleep_count, al          ;each time doze re-
entered
    or pm_flags, PM_DOZE        ;in doze
    dbPC fTEST2+fTESTb "d"

slow_cpu:
    call oem_pm_halt            ;slow cpu, do halt

;=== When we start up here, the sleep_check will already
have
; been run and taken the early return

    call oem_pm_activity?
    jz ck_sleep                ;no, chk sleep

    and pm_flags, not PM_DOZE   ;clear doze flag
    jmp exit_w_activity        ;yes, normal

;=====
; Decrement Sleep Counters...
;=====
;
; At this point, we enter check the SLEEP counters
; for criteria to enter that STATE. If not, reenter
; the DOZE loop
;

```

## TABLE 1

```

ck_sleep:
  sub  al,al                ;register zero
  cmp  sleep_timeout,al    ;sleep allowed...
  jz   slow_cpu            ;NO
  cmp  sleep_count,al     ;sleep time??
  jnz  slow_cpu            ;no
  call sleep               ;enter sleep mode
  and  pm_flags, not PM_DOZE ;clear doze flag
  jmp  exit_w_activity     ;because we came out...

```

```

page

```

```

;=====
; Sleep
;=====
;
; At this point, we enter SLEEP, having fulfilled the
; criteria to enter that STATE
;
; Save, in order:
; Video Adaptor state
; LCD state
; 8250 modes
; LPT modes
; Timer Mask
;=====

```

```

Sleep:
  dbPC fTEST2+fTESTb "S"
  push di
  push si
  push cx

  mov  di,offset sleep_save_buf
  cld

  and  pm_flags, not PM_SLEEP ;starting sleep req

assume cs:code,ds:data0,es:pmdata
  push ds
  pop  es
  mov  ds,data0p

```

```

;=====
; save Display State
;=====
  call oem_pm_save_video_state

;=====
; save COM, LPT setups
;=====

```

TABLE 1

```

mov dx, COM1 ;get COM1
call read_com
mov dx, COM2 ;get COM2
call read_com

mov dx, LPT1 ;get LPT1
call read_lpt
mov dx, LPT2
call read_lpt
mov dx, LPT3
call read_lpt

call oem_pm_save_peripherals ;for private stuff...

sleep_cpu:
in al, PIC1 ;get timer mask
stosb ;save
or al, TMRINT
out PIC1,al ;disable the timer interrupt

assume cs:code,ds:pndata,es:data0
push es
pop ds
mov es,data0p ;swap ES/DS

mov ax,sleep_power_status ;turns off stuff...
call oem_pm_turn_off_peripherals ;actually turns off
stuff...
ret
page

wake:
;==== Restore Peripheral Status=====
;
; Because we are here, this means the wakeup key
; was pressed, or an external interrupt came in.
; Time to wake up...
;
;
; Restore, in order:
; Video Adaptor state
; 8250 mode
; LPT mode
; Timer Interrupt
;=====

cli
mov ax,on_power_status ;What to turn on...
call oem_pm_turn_on_peripherals ;go do it

```

TABLE 1

```

mov si,offset sleep_save_buf      ;start of save area
cld

;=====
; Restore Display State
;=====

call oem_pm_restore_video_state

;=====
; restore COM and PRN
;=====
mov dx,COM1                        ;get com port
call write_com
mov dx,COM2                        ;get com port
call write_com

mov dx,LPT1                        ;restore lpt port
call write_lpt
mov dx,LPT2                        ;restore lpt port
call write_lpt
mov dx,LPT3                        ;restore lpt port
call write_lpt

call oem_pm_restore_peripherals    ;for private stuff...

push ds
call set_ibm_timer                 ;restore ticks...
pop ds

lodsb
out PIC1,al                        ;reenable interrupts
pop cx
pop si
pop di
dbPC fTEST2+fTESTb "G"
ret
page

;=====
; suspend
;=====
;
; Swap stacks, to
;
;
assume cs:code,es:data0,ds:pmdata

suspend proc

```

TABLE 1

```

;===== Save User Stack=====
cli
mov ax,ss
mov pm_save_ss, ax ;save stack
mov ax,sp
mov pm_save_sp, ax
sti

;===== Run On Resume Stack=====
mov ax, ds
mov ss, ax ;setup resume stack
mov sp, offset pm_resume_stack

mov es,data0p
mov reset_flag, FRESTORE

call checksum ;check this memory
mov pm_ram_chksum, ax ;save in pm_datat
call sleep ;save it all...
call oem_pm_suspend ;do it...

;=====
; pm_resume
;=====
;
; Cold Boot code jmps here with BP as no resume
; return address...
;
; check for a valid resume, do so
;
; otherwise, jmp bp to cold boot code

resume:
mov es,data0p
cmp reset_flag, FRESTORE
jnz resume_err

;===== PM data should still be valid =====

call get_pm_ds ;get datasg
mov ax, ds
mov ss, ax ;setup resume stack
mov sp, offset pm_resume_stack

call checksum
cmp ax, pm_ram_chksum
jnz resume_err

```

TABLE 1

```
call wake ;restore devices...
;===== Restore User Stack =====
mov ax, pm_save_ss
mov ss, ax
mov sp, pm_save_sp
ret ;to suspend caller

resume_err:
jmp bp ;return to do a hard
reset
suspend endp

code ends
end
```

TABLE 2Program Listing

A computer program embodiment of the software monitor for the power management unit appears in the following TABLE 2.

```

;----- ;
; Do power management functions of int 16h and int 8h
;
; Copyright - 1990 Vadem, Inc.
;
; All Rights Reserved.
;
; C:
;----- ;

code segment public 'code'
assume cs:code

org 100h
start:
jmp init
even

pp_addr dw 0378h

old_i8 label dword
i8_off dw 0
i8_seg dw 0ffffh

old_i10 label dword
i10_off dw 0 ; vector to old i10
i10_seg dw 0ffffh

old_i16 label dword
i16_off dw 0 ; vector to old i16
i16_seg dw 0ffffh

sctr db 0 ; counter for timeouts
two_ctr dw 12*182 ; 2 minute counter

;---- Interrupt 10h handler
new_i10:
call busy_check
jmp old_i10

;---- Interrupt 8 handler
new_i8:
call busy_check

```

TABLE 2

```

jmp old_i8

busy_check:
  cmp  sctr,0      ; already in faxt mode?
  jz   i8fast_mode
  sub  sctr,50
  jz   i8fast_mode
  jnc  i8z
  mov  sctr,0
;---- Switch to turbo mode here!
i8fast_mode:
  cmp  two_ctr,0   ; if timed out, do nothing
  jz   i8z         ; let IO monitor take over
;--- Two minutes have not gone by, turn it to ON! ----
  dec  two_ctr
  push dx
  push ax
  mov  dx,0178h
  mov  al,0c0h
  out  dx,al
  inc  dx
  in   al,dx      ; get status of chip
  mov  ah,al
  and  al,3      ; LSB 2 bits
  jz   i8q       ; if not ON, nothing to do!
  dec  dx
  mov  al,0c0h
  out  dx,al
  inc  dx
  mov  al,ah
  and  al,not 3  ; set to ON mode
  out  dx,al
i8q:
  pop  ax
  pop  dx
i8z:
  ret

;---- Interrupt 16 interceptor
new_i16:
;---- Time to switch from ON to DOSE mode? ----
  push ax
  push dx
  mov  dx,0178h
  mov  al,0c0h
  out  dx,al
  inc  dx
  in   al,dx      ; get status of chip
  mov  ah,al
  and  al,3      ; LSB 2 bits
  jnz  i16_dose  ; if not ON, nothing to do!

```



TABLE 2

```

;--- Check to see if time to go into DOSE...
    add  sctr,24
    jnc  i16q
;--- Time to go into DOZE!
    dec  dx
    mov  al,0c0h
    out  dx,al
    inc  dx
    mov  al,ah
    or   al,1      ; set to dose mode
    out  dx,al     ; we are now in DOSE mode!
    jmp  short i16setctrs
;--- We are already in DOSE mode, count faster!
i16_dose:
    add  sctr,200
    jnc  i16q
i16setctrs:
    mov  sctr,0ffh      ; clamp it
    mov  two_ctr,12 * 182 ; 18.2 Hz * 120 seconds
i16q:
    pop  dx
    pop  ax
    jmp  old_i16        ; do the original i16

init_str      db  'Power management controller version 1.00.$'

    assume    ds:code
init:
    mov  dx,offset init_str
    mov  ah,9
    int  21h

    mov  ax,3508h
    int  21h
    mov  i8_seg,es
    mov  i8_off,bx
    push ds
    pop  es

    mov  dx,offset new_i8
    mov  ax,2508h
    int  21h

    mov  ax,3510h
    int  21h
    mov  i10_seg,es
    mov  i10_off,bx
    push ds
    pop  es

    mov  dx,offset new_i10

```

TABLE 2

```
mov ax,2510h
int 21h

mov ax,3516h
int 21h
mov i16_seg,es
mov i16_off,bx
push ds
pop es

mov dx,offset new_i16
mov ax,2516h
int 21h

mov dx,offset init_str+15
mov cl,4
shr dx,cl
mov ax,3100h
int 21h

code ends
end start
```

While the invention has been particularly shown and described with reference to preferred embodiments thereof, it will be understood by those skilled in the art that the foregoing and other changes in form and details may be made therein without departing from the spirit and scope of the invention.

What is claimed is:

1. A computer system comprising a power management system and a plurality of computer system circuits including a CPU circuit, a plurality of input/output circuits, a memory circuit, and a system bus which directly connects the CPU circuit with the input/output circuits, said computer system adapted to perform a plurality of activities, wherein said power management system comprises:

an activity monitor which monitors the activity of the computer system including:

means for identifying each of said plurality of activities as either an active activity or an idle activity and for associating each of said plurality of activities with a predetermined activity value and with either a first arithmetic sign for activities identified as active activities or with a second arithmetic to said first sign for activities identified as idle activities;

an activity count accumulator for accumulating an activity count upon the occurrence of each of said plurality of activities including: means for adding to a stored activity count, upon the occurrence of any one of said plurality of activities, a predetermined activity value associated with said particular activity; and

means for comparing the accumulated stored activity count with a conserve threshold and for causing a CONSERVE signal if the accumulated activity count has a predetermined algebraic relationship relative to the conserve threshold; and

a mode controller responsive to the activity monitor wherein the mode controller has a plurality of power modes of operation including a first mode and a second mode; and

a power control circuit coupled to said activity monitor which in response to the CONSERVE signal transitions from an ON state to a REDUCED state in which the power consumption of the computer is reduced relative to the power consumption in the ON state.

2. The computer system in claim 1, wherein said power control circuit further comprises: a plurality of power switching circuits wherein each power switching circuit controls the power supply to one of the computer system circuits, and wherein each power switching circuit comprises:

a switch which selectively couples a power supply to one of the computer system circuits; a plurality of memory cells associated with the switch including a first memory cell and a second memory cell; a multiplexer coupled to the switch and responsive to the mode controller; wherein the multiplexer couples the first memory cell to the switch in said first mode of the mode controller such that the state of the first memory cell controls whether the switch is open or closed; and wherein the multiplexer couples the second memory cell to the switch in said second mode of the mode controller such that the state of the second memory cell controls whether the switch is open or closed;

whereby the power supply is selectively coupled to the plurality of computer system circuits and the power consumption of the computer system is controlled in response to the activity of the computer system.

3. The computer system of claim 2 wherein the plurality of memory cells associated with the switch of each power switching circuit can be programmed by the CPU such that the status of the plurality of switches in each of the plurality of modes of operation of the mode controller is programmable.

4. The computer system of claim 3 further comprising a polarity circuit coupled between each plurality of memory cells and each switch wherein the polarity circuit selectively inverts the output of the plurality of memory cells associated with each switch.

5. The computer system of claim 2 wherein the mode controller has at least three modes of operation including a third mode;

wherein the switch of each power switching circuit is associated with a third memory cell; and

wherein the multiplexer of each power switching circuit couples the third memory cell to the switch of each power switching circuit in said third mode of the mode controller such that the state of the third memory cell controls whether each switch is open or closed.

6. The computer system of claim 5 wherein the plurality of memory cells associated with the switch of each power switching circuit can be programmed by the CPU such that the status of the plurality of switches in each of the plurality of modes of operation of the mode controller is programmable.

7. The computer system of claim 5 further comprising a polarity circuit coupled between each plurality of memory cells and each switch wherein the polarity circuit selectively inverts the output of the plurality of memory cells associated with each switch.

8. A power management system for use in a computer system comprising a power supply, a plurality of computer system circuits including a CPU circuit, an input/output circuit, and a memory circuit, a system bus which connects the CPU circuit with said input/output circuit and said memory circuit, and a plurality of power control switches which selectively couple the power supply to at least some of the plurality of computer system circuits, said computer system performing a plurality of activities, wherein said power management system comprises:

an activity monitor which monitors the activity of the computer system including monitoring said system bus which connects said CPU circuit with said input/output circuit and with said memory circuit and generates an activity indicator signal reflective of said monitored activity; said activity monitor including identification logic identifying each of said plurality of activities as either an active activity or an idle activity and for associating each of said plurality of activities with a predetermined activity value for each particular activity having magnitude and algebraic sign, an activity count accumulator for accumulating an activity count based on said magnitude and sign upon the occurrence of one of said activities, and a comparator for comparing the accumulated activity count with a threshold count and for causing said activity indicator signal if the accumulated activity count has a predetermined algebraic relationship relative to the threshold count;

a mode controller establishing the mode of operation of said computer and responsive to the activity indicator signal of said activity monitor and having a plurality of modes of operation; and

a power switching circuit comprising:

a plurality of power control lines each for controlling the open or closed state of one of the plurality of power control switches;

a memory cell associated with said plurality of control lines; and

power director means which in response to the mode of operation established by said mode controller selectively couples each of the plurality of power control lines to said memory cell such that a signal is generated on the power control line that is dependent upon the state of the memory cell;

said plurality of switches being controlled by the power switching circuit so that the power consumption of the computer system is controlled in response to the monitored activity of the computer system.

9. The power management system of claim 8 wherein the memory cell associated with each of the plurality of power control lines of the power switching circuit can be programmed by the CPU such that the status of the plurality of power control switches in each of the plurality of modes of operation of the mode controller is programmable.

10. The computer system of claim 9 further comprising a polarity circuit coupled between each memory cell and each power control line wherein the polarity circuit selectively inverts the output of the memory cell associated with each power control line.

11. The power management system of claim 8 wherein the mode controller has at least three modes of operation; wherein each of the plurality of power control lines is associated with a bit stored in said memory cell; wherein said bit in said memory cell is alterable depending upon said mode; and wherein the power director means alters said bit to change control data on that power control line in each of the three modes of operation.

12. A power management system for use in a computer system comprising a power supply, a plurality of computer system circuits including a CPU circuit, an input/output circuit, and a memory circuit, a system bus which directly connects the CPU circuit with said input/output circuit and said memory circuit, and a plurality of power control switches which couple the power supply to provide operating power including bias voltages to transistors within said computer system circuits to the plurality of computer system circuits, wherein said power management system comprises:

an activity monitor which monitors the activity of the computer system and generates an activity indicator signal reflective of said monitored activity;

a mode controller responsive to the activity indicator signal of said activity monitor and having a plurality of modes of operation;

a power switching circuit comprising:

a plurality of power control lines each for controlling one of the plurality of power control switches;

a memory cell associated with each of the plurality of control lines; and

power director means which in response to the mode of operation of the mode controller selectively couples each of the plurality of power control lines to said memory cell associated with that power control line such that a signal is generated on the power control line that is dependent upon the state of the memory cell to which it is coupled;

whereby the plurality of switches are controlled by the power switching circuit and the power consumption of the computer system is controlled in response to the activity of the computer system; and wherein the mode controller has at least three modes of operation; each of the plurality of power control lines is associated with a bit stored in said memory cell;

said bit in said memory cell is alterable depending upon said mode; and

the power director means alters said bit to change control data on that power control line in each of the three modes of operation;

said power director means includes a multiplexer circuit, and the power switching circuit further comprises a polarity circuit coupled to the output of the multiplexer and to a plurality of the plurality of power control lines; the polarity circuit comprises a plurality of polarity bits; each polarity bit has two states;

in a first state of each polarity bit the polarity circuit inverts the signal on a corresponding power control line relative to the state of a corresponding associated memory cell; and

wherein in the second state of each polarity bit the polarity circuit does not invert the signal on a corresponding power control line relative to the state of a corresponding associated memory cell.

13. A method for operating a computer system comprising a plurality of computer system circuits including a CPU circuit, a plurality of input/output circuits, and a memory circuit, a system bus which directly connects the CPU circuit with said plurality of input/output circuits and said memory circuit, a plurality of power control switches which selectively couple a power supply to the computer system circuits and having a plurality of functional power modes, wherein the method comprises the steps of:

programming a first power control bit associated with each power control switch;

programming a second power control bit associated with each power control switch;

monitoring the activity of the computer system including identifying at least some of said plurality of activities as either active class or idle class activities and associating said at least some activities with an activity value having a magnitude component and algebraic sign component wherein said idle class activities have a sign opposite to said active class activities, accumulating an activity count as the sum of said activity values for each activity occurring during a predetermined monitoring period, and comparing the accumulated activity count with a threshold count and generating an indicator signal if the accumulated activity count has a predetermined algebraic relationship relative to the threshold count;

switching the power mode of the computer system from a first mode to a second mode in response to said generated indicator signal indicating a first level of inactivity in the computer system;

providing a signal to each of the plurality of power control switches dependent upon the state of the associated first power control bit in said first mode of the mode controller such that the state of that bit controls whether the switch is open or closed in said first mode; and

providing a signal to each of the plurality of power control switches dependent upon the state of the associated second power control bit in said second mode of the mode controller such that the state of that bit controls whether the switch is open or closed in said second mode;

whereby the power consumption of the computer system is controlled in response to the activity of the computer system.

14. The method of claim 13 further comprising the step of:

programming a polarity control bit;

and wherein the step of providing a signal to each of the plurality of power control switches dependent upon the state of the associated first power control bit in said first mode of the mode controller comprises the step of selectively inverting the signal provided to each of the plurality of power control switches relative to the state of the associated power control bit depending upon the state of the polarity control bit;

and wherein the step of providing a signal to each of the plurality of power control switches dependent upon the state of the associated second power control bit in said second mode of the mode controller comprises the step of selectively inverting the signal provided to each of the plurality of power control switches relative to the state of the associated power control bit depending upon the state of the polarity control bit.

15. The method of claim 13 further comprising the steps of:

programming a third power control bit associated with each of the plurality of power control switches;

switching the power mode of the computer system from said second mode to a third mode in response to a second level of inactivity of the computer system;

and providing a signal to each of the plurality of power control switches dependent upon the state of the associated third power control bit in said third mode of the computer system such that the state of that bit controls whether the switch is open or closed in third mode.

16. A method for operating a computer system comprising a plurality of computer system circuits including a CPU circuit, a plurality of input/output circuits, and a memory circuit, a system bus which directly connects the CPU circuit with said plurality of input/output circuits and said memory circuit, a plurality of power control switches which selectively couple a power supply to the computer system circuits and having a plurality of functional power modes, wherein the method comprises the steps of:

programming a first power control bit associated with each power control switch;

programming a second power control bit associated with each power control switch;

monitoring the activity of the computer system and switching the power mode of the computer system from a first mode to a second mode in response to a first level of inactivity in the computer system;

providing a signal to each of the plurality of power control switches dependent upon the state of the associated first power control bit in said first mode of the mode controller such that the state of that bit controls whether the switch is open or closed in said first mode;

providing a signal to each of the plurality of power control switches dependent upon the state of the associated second power control bit in said second mode of the mode controller such that the state of that bit controls whether the switch is open or closed in said second mode;

programming a third power control bit associated with each of the plurality of power control switches;

switching the power mode of the computer system from said second mode to a third mode in response to a second level of inactivity of the computer system;

providing a signal to each of the plurality of power control switches dependent upon the state of the associated third power control bit in said third mode of the

computer system such that the state of that bit controls whether the switch is open or closed in third mode; and programming a polarity control bit;

said step of providing a signal to each of the plurality of power control switches dependent upon the state of the associated first power control bit in said first mode of the mode controller further comprises the step of selectively inverting the signal provided to each of the plurality of power control switches relative to the state of the associated power control bit depending upon the state of the polarity control bit;

said step of providing a signal to each of the plurality of power control switches dependent upon the state of the associated second power control bit in said second mode of the mode controller comprises the step of selectively inverting the signal provided to each of the plurality of power control switches relative to the state of the associated power control bit depending upon the state of the polarity control bit; and

said step of providing a signal to each of the plurality of power control switches dependent upon the state of the associated second power control bit in said third mode of the mode controller comprises the step of selectively inverting the signal provided to each of the plurality of power control switches relative to the state of the associated power control bit depending upon the state of the polarity control bit;

whereby the power consumption of the computer system is controlled in response to the activity of the computer system.

17. In a power consumption management system for a computer system having a plurality of computer system devices receiving operating power from a common computer power supply, said computer system devices including a CPU device, an input/output device, and a memory device, and a single common system bus which directly connects the CPU device with the input/output device and the memory device, and wherein said computer system is adapted to perform a plurality of activities and has an activity level and a power consumption level as a result of performance of at least one of said plurality of activities; an activity monitor comprising:

means for identifying each of said plurality of activities as either an active activity or an idle activity and for associating each of said plurality of activities with a predetermined activity value and with either a first arithmetic sign for activities identified as active activities or with a second arithmetic sign opposite to said first sign for activities identified as idle activities;

an activity count accumulator for accumulating an activity count during a first predetermined time interval upon the occurrence of each of said plurality of activities including means for adding to a stored activity count, upon the occurrence of any one of said plurality of activities, a predetermined activity value associated with said particular activity;

a comparator for comparing the accumulated stored activity count within said first predetermined time interval with a first threshold and for generating a first conserve power signal if the accumulated activity count is equal to the first threshold; and

means for withholding said operating power from any one or more selected ones of said plurality of computer system devices in response to said first conserve power signal.

18. The activity monitor in claim 17, wherein said activity count accumulator further accumulates said activity count

during a second predetermined time interval longer than said first interval; wherein said comparator compares said count accumulated during said second interval with a second threshold and generates a second conserve power signal if the count accumulated during said second interval is equal to a second threshold; and wherein said means for withholding said operating power withholds operating power from any one or more selected ones of said plurality of computer system devices in response to said second conserve power signal, a number of devices from which said power is withheld being greater than the number of devices from which said operating power is withheld in response to said first conserve signal.

19. The activity monitor in claim 18, wherein said activity count accumulator further accumulates said activity count during a third predetermined time interval longer than said second interval; wherein said comparator compares said count accumulated during said third interval with a third threshold and generates a third conserve power signal if the count accumulated during said third interval is equal to a third threshold; and wherein said means for withholding said operating power withholds operating power from any one or more selected ones of said plurality of computer system devices in response to said third conserve power signal, a number of devices from which said power is withheld being greater than the number of devices from which said operating power is withheld in response to said second conserve signal.

20. In a power consumption management system for a computer system having a plurality of computer system devices receiving operating power from a common computer power supply, said computer system devices including a CPU device, an input/output device, and a memory device, and a system bus which connects the CPU device with the input/output device and the memory device, and wherein said computer system is adapted to perform a plurality of activities and has an activity level and a power consumption level as a result of performance of at least one of said plurality of activities; a method for monitoring activity of said computer system comprising the steps of:

identifying each of said plurality of activities as either an active activity or an idle activity and associating each of said plurality of activities with a predetermined activity value and with either a first arithmetic sign for activities identified as active activities or with a second arithmetic sign opposite to said first sign for activities identified as idle activities;

accumulating an activity count during a first predetermined time interval upon the occurrence of each of said plurality of activities including adding to a stored activity count, upon the occurrence of any one of said plurality of activities, a predetermined activity value associated with said particular activity;

comparing the accumulated stored activity count within said first predetermined time interval with a first threshold and generating a first conserve power signal if the accumulated activity count is within a predetermined range of the first threshold; and

withholding said operating power from any one or more selected ones of said plurality of computer system devices in response to said first conserve power signal.

21. The activity monitor in claim 20, wherein step of accumulating an activity count further includes the step of accumulating said activity count during a second predetermined time interval longer than said first interval; and

said step of comparing further includes the step of comparing said count accumulated during said second

interval with a second threshold and generating a second conserve power signal if the count accumulated during said second interval is within a predetermined range of a second threshold; and

said step of withholding said operating power includes the step of withholding operating power from any one or more selected ones of said plurality of computer system devices in response to said generation of said second conserve power signal, a number of devices from which said power is withheld in response to generation of said second conserve signal being greater than the number of devices from which said operating power is withheld in response to said first conserve signal.

22. The activity monitor in claim 21, wherein step of accumulating an activity count further includes the step of accumulating said activity count during a third predetermined time interval longer than said second interval;

said step of comparing further includes the step of comparing said count accumulated during said third interval with a third threshold and generating a third conserve power signal if the count accumulated during said third interval is within a predetermined range of a third threshold; and

said step of withholding said operating power includes the step of withholding operating power from any one or more selected ones of said plurality of computer system devices in response to said generation of said third conserve power signal, a number of devices from which said power is withheld in response to generation of said third conserve signal being greater than the number of devices from which said operating power is withheld in response to said second conserve signal.

23. In a computer system having a power management system and a plurality of computer system circuits including a CPU circuit, a plurality of input/output circuits, a memory circuit, a power supply for providing electrical power to operate at least one of said computer system circuits, a clock circuit for generating a clock signal, and a system bus which connects the CPU circuit with the input/output circuits, and wherein said computer system is adapted to perform a plurality of activities, a method for managing power use by said computer system comprising the steps of:

monitoring the activity of the computer system including the steps of:

identifying each of said plurality of activities as either an active activity or an idle activity and associating each of said plurality of activities with a predetermined activity value and with either a first arithmetic sign for activities identified as active activities or with a second arithmetic sign opposite to said first sign for activities identified as idle activities;

accumulating an activity count upon the occurrence of each of said plurality of activities including adding to a stored activity count, upon the occurrence of any one of said plurality of activities, a predetermined activity value associated with said particular activity; and

comparing the accumulated stored activity count with a conserve threshold and for causing a conserve signal if the accumulated activity count has a predetermined algebraic relationship relative to the conserve threshold;

controlling a power mode of operation in response to said conserve signal to select a mode of operation from among at least a first mode and a second mode; and controlling power consumption of said computer by transitioning operation of at least one of said computer

system circuits from an on state to a reduced power state in response to the conserve signal in which the power consumption of the computer is reduced relative to the power consumption in the on state.

24. The method in claim 23, wherein said step of controlling power consumption of said computer further comprises the step of controlling distribution of electrical power from said power supply to one of said computer system circuits.

25. The method in claim 24, wherein said step of controlling distribution of electrical power further comprises the steps of:

associating at least some of said plurality of computer system circuits with a power control value for each of said on state and reduced state, wherein said on and reduced power control value identify whether power is to be provided to or withheld from said computer system circuits during operation in said on state and said reduced state; and

switchably controlling the connection of said power supply to said at least some of said computer system circuits based on said on and reduced power control values.

26. The method in claim 24, wherein said step of associating at least some of said plurality of computer system circuits with a power control value for each of said on state and said reduced state further comprises the steps of: providing a plurality of control bits for each of said on and reduced power control values in said memory; and associating each said control bit with a group of said devices, wherein each said control bit can have a first logical state or a second logical state; and wherein said step of switchably controlling the connection of said power supply to said at least some of said computer system circuits based on said on and said reduced power control values further comprises the step controlling the connection of said power supply to said devices based on the logic state of said associated control bit to close a switch and thereby connect said power supply to said device when only when said control bit has said first logic state.

27. The method in claim 23, wherein said step of controlling power consumption of said computer further comprises the step of controlling the frequency of said clock signal distributed to one of said computer system circuits.

28. A computer system comprising a power management system and a plurality of computer system circuits including a processor circuit, at least one input/output circuit, a

memory circuit, and a bus which connects the processor circuit with the input/output circuit, said computer system adapted to perform a plurality of processing activities, wherein said power management system comprises:

an activity monitor which monitors the processing activity of said computer system including:

identification logic identifying each of said plurality of activities as either an active class activity or an idle class activity and associating each of said plurality of activities with a predetermined activity value and with either a first arithmetic sign for activities identified as active class activities or with a second arithmetic sign opposite to said first sign for activities identified as idle class activities;

an activity count accumulator for accumulating an activity count upon the occurrence of each of said plurality of activities including and adder for adding to a previous activity count, upon the occurrence of any one of said plurality of activities, a predetermined activity value associated with said particular activity; and

a comparator coupled to said accumulator to receive said accumulated activity count and for comparing the accumulated activity count with a conserve threshold and for causing a conserve signal if the accumulated activity count has a predetermined algebraic relationship relative to the conserve threshold;

a mode controller responsive to the activity monitor wherein the mode controller has a plurality of power modes of operation including a first mode and a second mode; and

a control circuit coupled to said activity monitor and responsive to said activity monitor which in response to the conserve signal transitions said computer system from an on state to a reduced power consumption state in which the power consumption of the computer system is reduced relative to the power consumption in the on state by either: (i) removing a clock signal communicated to at least one of said computer system circuits, (ii) reducing the operating frequency of a clock signal communicated to at least one of said computer system circuits, (iii) reducing the electrical power delivered to at least one of said computer system circuits, or (iv) by a combination thereof.

\* \* \* \* \*