

# EXHIBIT A



US006360167B1

(12) **United States Patent**  
**Millington et al.**

(10) **Patent No.:** **US 6,360,167 B1**  
(45) **Date of Patent:** **Mar. 19, 2002**

(54) **VEHICLE NAVIGATION SYSTEM WITH LOCATION-BASED MULTI-MEDIA ANNOTATION**

|             |         |                    |                             |
|-------------|---------|--------------------|-----------------------------|
| 5,627,549 A | 5/1997  | Park               |                             |
| 5,664,948 A | 9/1997  | Dimitriadis et al. |                             |
| 5,682,525 A | 10/1997 | Bouve et al.       |                             |
| 5,802,492 A | 9/1998  | DeLorme et al.     |                             |
| 5,887,269 A | *       | 3/1999             | Brunts et al. .... 701/208  |
| 5,938,721 A | *       | 8/1999             | Dussell et al. .... 701/211 |

(75) Inventors: **Jeffrey Alan Millington**, Rochester Hills; **Larry E. Spencer, II**, Lake Orion; **Donald J. Long**, Sterling Heights; **Richard Eklund**, Rochester; **Michael G. Lambie**, Lake Orion, all of MI (US)

**FOREIGN PATENT DOCUMENTS**

(73) Assignee: **Magellan DIS, Inc.**, Rochester Hills, MI (US)

|    |            |   |         |
|----|------------|---|---------|
| DE | 4033326 A1 | * | 4/1991  |
| EP | 0875729    |   | 11/1998 |
| FR | 2691276    |   | 11/1993 |
| FR | 2743168    |   | 7/1997  |
| JP | 8-76706    | * | 3/1996  |
| JP | 8-138193   | * | 5/1996  |
| JP | 8-190574   | * | 7/1996  |
| JP | 9-288445   | * | 11/1997 |
| JP | 9-329449   | * | 12/1997 |

(\*) Notice: Subject to any disclaimer, the term of this patent is extended or adjusted under 35 U.S.C. 154(b) by 0 days.

\* cited by examiner

(21) Appl. No.: **09/239,692**

*Primary Examiner*—Bernarr E. Gregory

(22) Filed: **Jan. 29, 1999**

(74) *Attorney, Agent, or Firm*—Carlson, Gaskey & Olds

(51) **Int. Cl.**<sup>7</sup> ..... **G01C 21/00**; G01C 21/26

(57) **ABSTRACT**

(52) **U.S. Cl.** ..... **701/211**; 701/207; 701/208; 701/213; 342/357.06; 342/357.13

A navigation system provides multimedia annotations based upon the present location of the vehicle. These presentations may comprise advertising or text or other information entered by the user and associated with a specific location or locations. The navigation system also provides a removable media reader which obtains additional information based upon which the navigation system operates. This additional information may include multimedia annotations which are location-based. The navigation system further includes a wireless communication system which interacts with and provides further location-based multimedia annotations.

(58) **Field of Search** ..... 342/357.01–357.17; 701/207–216

(56) **References Cited**

**U.S. PATENT DOCUMENTS**

|             |         |                    |         |
|-------------|---------|--------------------|---------|
| 4,951,212 A | 8/1990  | Kurihara et al.    |         |
| 4,973,952 A | 11/1990 | Malec et al.       |         |
| 5,353,034 A | 10/1994 | Sato et al. ....   | 342/457 |
| 5,470,233 A | 11/1995 | Fruchterman et al. |         |
| 5,499,181 A | 3/1996  | Smith              |         |
| 5,559,707 A | 9/1996  | DeLorme et al.     |         |

**44 Claims, 3 Drawing Sheets**

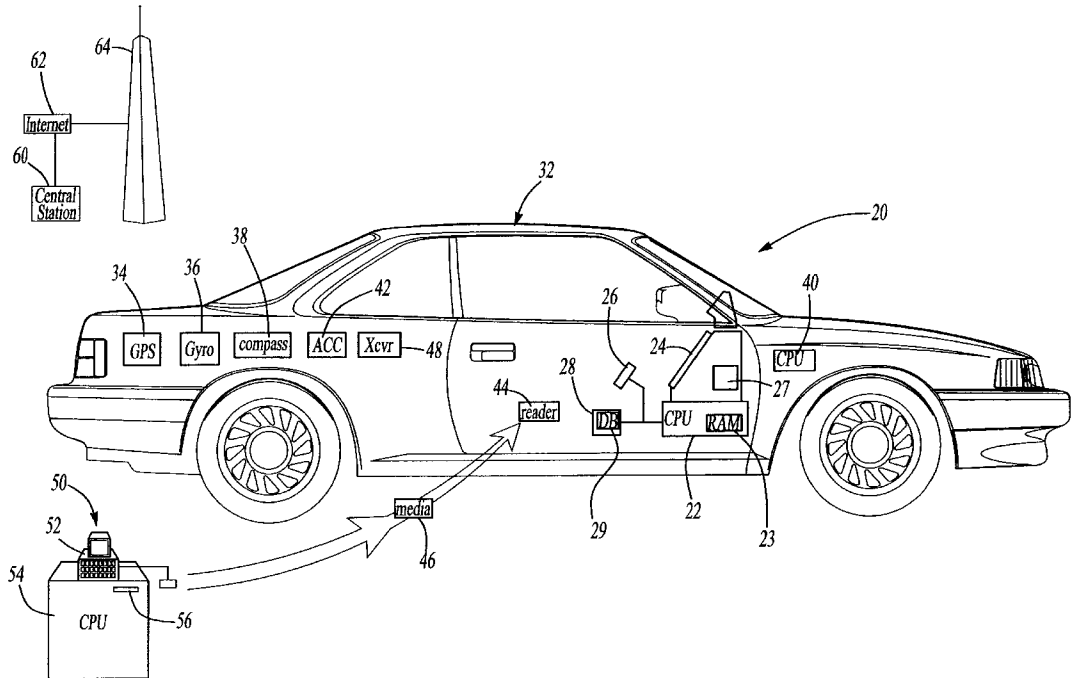

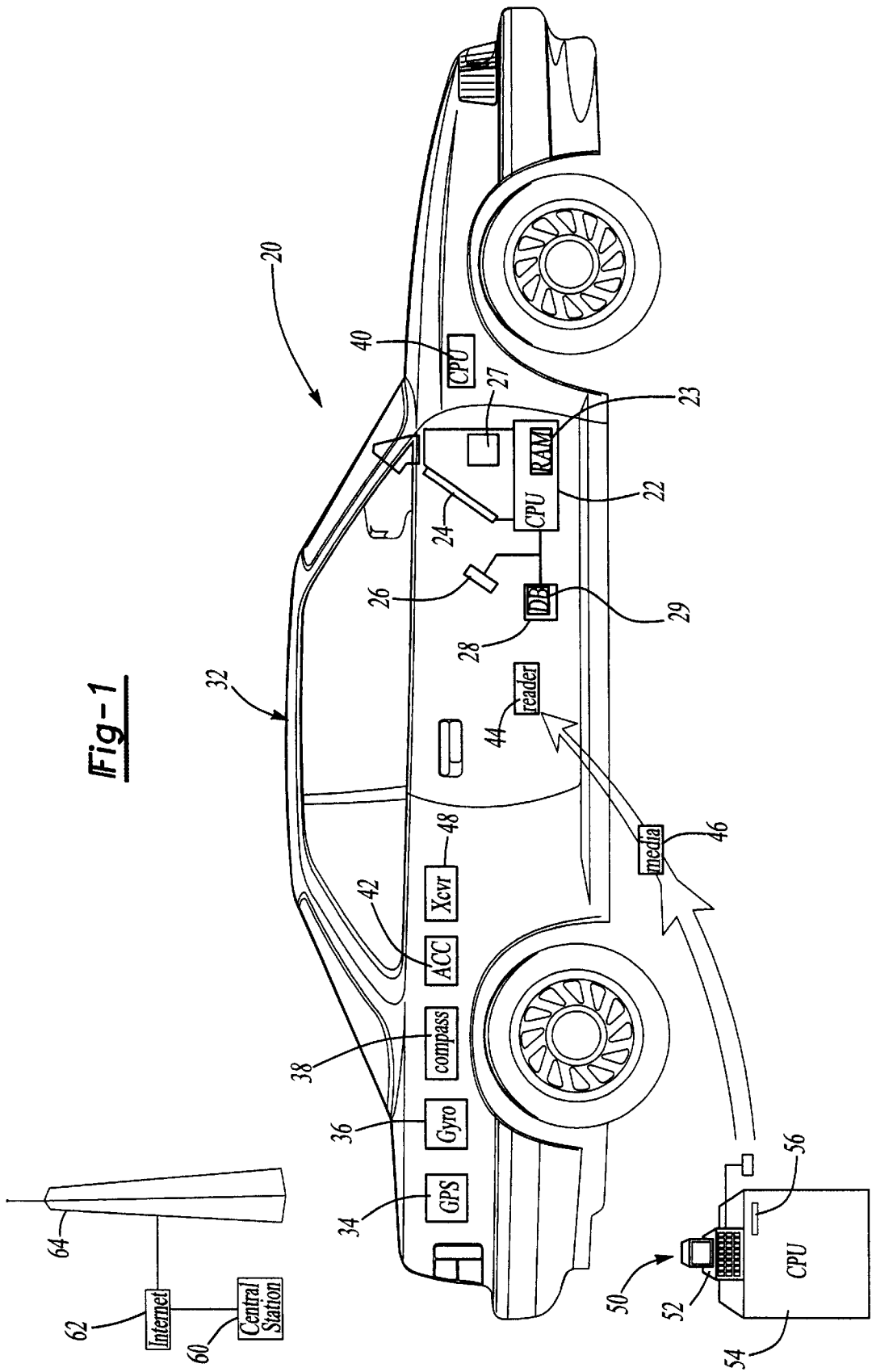

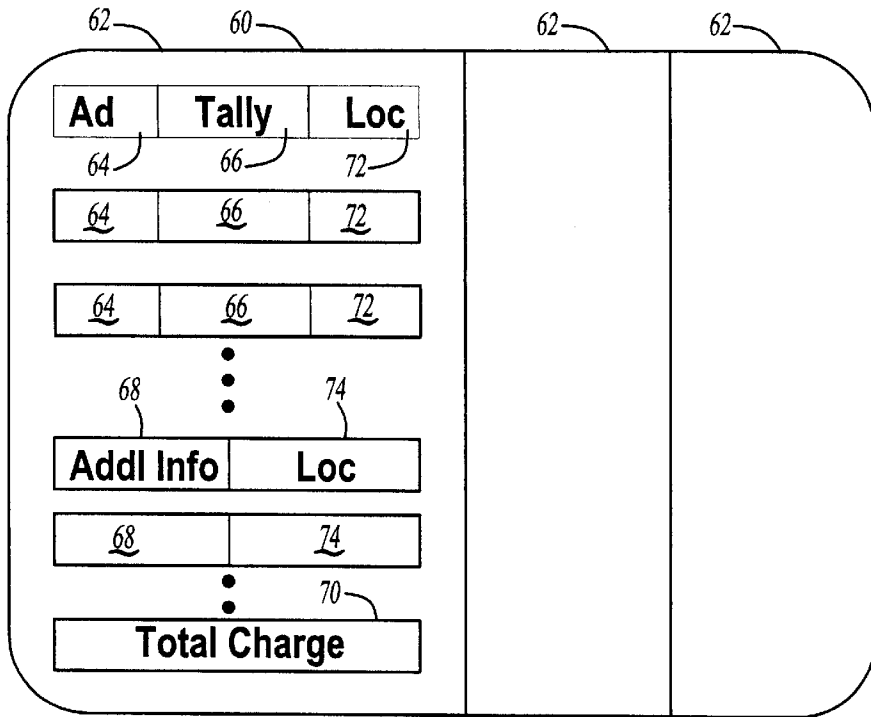

Fig-2

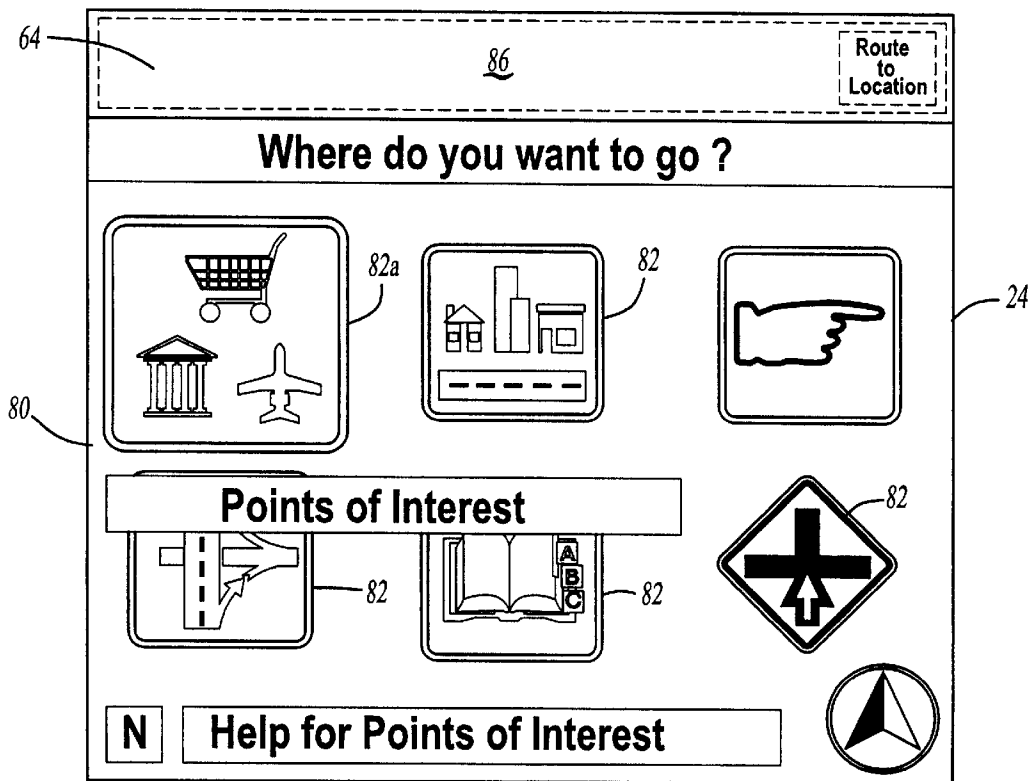

Fig-3

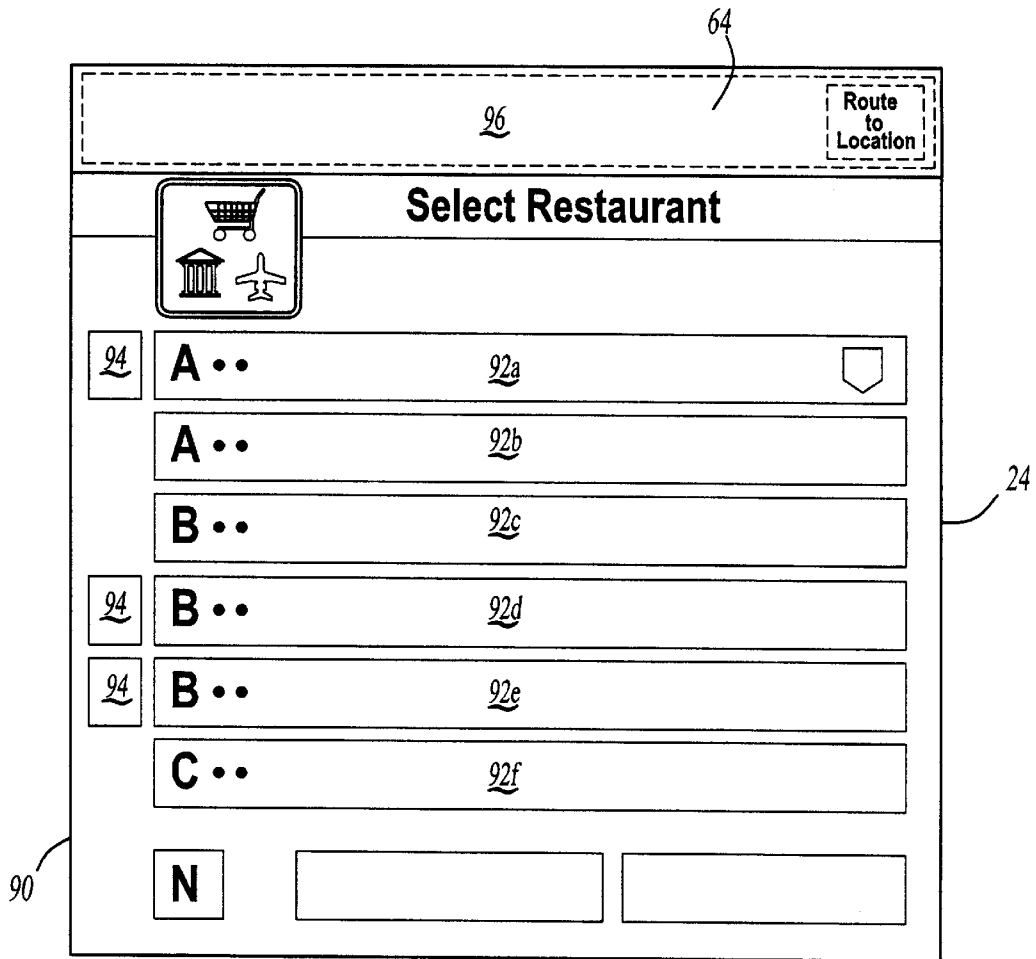

Fig-4

## VEHICLE NAVIGATION SYSTEM WITH LOCATION-BASED MULTI-MEDIA ANNOTATION

### BACKGROUND OF THE INVENTION

The present invention relates generally to vehicle navigation systems.

Current vehicle navigation systems may include a variety of position determining devices, such as GPS receivers, accelerometers, gyros, speedometers, compasses, etc. in order to determine the position of the vehicle relative to a database of roads. As is well-known, a user selects a destination in the database of roads and the navigation system guides the user along the roads to the destination. The known navigation systems permit the user to select a destination by category. For example, the user can select the category of "restaurants" at which point restaurants in a selected area or the closest restaurants will be displayed. Upon selection of the desired restaurant, the navigation system will guide the user via the roads in the database to the destination. Currently, only the name of the restaurant is displayed, without any additional information. Thus, the user's decision about which restaurant to select must be based completely on the name of the restaurant. This is particularly difficult for the user in an unknown area selecting among restaurants other than national franchises.

Some current navigation systems guide the user to the destination via turn-by-turn instructions. Many users of vehicle navigation systems are travelers from out of town (and sometimes from out of the country) who are renting a vehicle in an area where they are unfamiliar with the roads and surrounding points of interest. Travelers from out of the country may understand little or none of the audible instructions originally installed in the navigation system because they are in a language other than their own, thus diminishing the value of the audible instruction.

Currently, it is impractical for rental car agencies to remove or disable permanently installed vehicle navigation systems from vehicles for renters who did not request (and pay for) the vehicle navigation system. As a result, potential revenue from rental fees for navigation systems may be lost.

Similarly, some vehicle navigation systems include a database of roads for nine or more geographic areas in the United States; however, typically, only one or a few of these geographic areas are enabled on the system purchased by the consumer, depending upon where the consumer intends to use the system. Thus, although it would be particularly useful, the consumer may be unable to utilize the navigation system in geographic areas to which the consumer may travel only occasionally for vacation.

### SUMMARY OF THE INVENTION

These and other drawbacks of known navigation systems are overcome by the navigation system of the present invention. The present invention provides a vehicle navigation system with location-based multimedia annotations (text, graphics and/or audio) in several different ways. First, "ads" comprising location-based multimedia annotations are periodically presented. These ads are presented based upon the current location of the vehicle relative to a location with which the ad is associated. Some ads are displayed at power-up independent of vehicle location, as will be explained below. The user also has the ability to request additional information associated with the ad. The additional information may be stored on the database of the navigation system, read by a removable media reader connected to the

navigation system or received via a wireless communication system on the vehicle. This additional information may include text, graphics, audio and/or multimedia presentations which relate to the ad selected by the user.

The navigation system of the present invention further provides a removable media reader which reads information from a removable media and provides that information to the navigation system, which operates based upon that information. For example, the removable media may include prestored routes, destinations, and additional location-based multimedia annotations. The navigation system of the present invention also provides a wireless communication system which provides the ads and the additional information to the navigation system and its user. The ads may be utilized to help defray the cost of the navigation system to the purchaser or user.

The removable media may also include audio data, such as audible turn instructions in a language other than that previously stored on the navigation system. The removable media may also include a code or codes which enable the navigation system or at least some functions of the navigation system. The code may be time specific, such that it only enables the system for a predetermined time period, or it may be geographically specific, such that it enables the navigation system to access additional geographic areas in its database. Alternatively, the code may be entered via the user input device.

It should be noted that there are many inventive features described here, many of which could be practiced alone, or in different combinations with the others as described. Those of reasonable skill in the art could determine ways of practicing any one or any combination of these features, which would still be considered part of the present invention.

### BRIEF DESCRIPTION OF THE DRAWINGS

Other advantages of the present invention will be readily appreciated as the same becomes better understood by reference to the following detailed description when considered in connection with the accompanying drawings wherein:

FIG. 1 is a schematic of the navigation system of the present invention installed in a vehicle;

FIG. 2 is a schematic representation of the central station of FIG. 1;

FIG. 3 is a first screen which is displayed on the display of FIG. 1; and

FIG. 4 is a second screen which is displayed on the display of FIG. 1.

### DETAILED DESCRIPTION OF A PREFERRED EMBODIMENT

The navigation system **20** of the present invention is shown schematically in FIG. 1. The navigation system **20** includes a CPU **22** having RAM **23** and connected to a display **24**, such as a high resolution LCD or flat panel display. The CPU **22** is also connected to an input device **26** such as a mouse, keyboard, key pad, remote device or microphone.

The user input device **26** is preferably a keypad comprising a plurality (preferably eight) of direction arrows which operate together with the display **24** to enter text, numbers, symbols, etc. or other alphanumeric characters. Preferably, the characters are entered utilizing the character entry system disclosed in co-pending application U.S. Ser. No.

09/096,103 entitled "A NAVIGATION SYSTEM CHARACTER INPUT DEVICE" filed on Mar. 10, 1998, which is hereby incorporated by reference. Alternatively, the display 24 can be a touch screen display.

The CPU 22 also includes at least one audio speaker 27 outputting sound from the CPU 22. The navigation system 20 further includes a storage device 28, such as a hard drive 28 and/or CD ROM, connected to the CPU 22. The storage device 28 contains a database 29 including a map of all the roads in the area to be traveled by the vehicle 32 as well as the locations of potential destinations, such as addresses, hotels, restaurants, or previously stored locations. The software for the CPU 22, including the graphical user interface, route guidance, operating system, position-determining software, etc may also be stored in storage device 28 and/or in the RAM 23 or alternatively in ROM or flash memory.

The navigation system 20 preferably includes position determining devices, such as a GPS receiver 34, a gyroscope 36, a compass 38, a wheel speed sensor 40 and a multi-axis accelerometer 42, all connected to the CPU 22 (connections not shown for simplicity). Suitable position and motion determining devices are well known and are commercially available.

As is well known, the position determining devices determine the position of the vehicle 32 relative to the database of roads utilizing dead-reckoning, map-matching, GPS, etc. Further, as is known in navigation systems, the user can select a destination relative to the database 29 of roads utilizing the input device 26 and the display 24. The navigation system 20 then calculates and displays a recommended route directing the driver of the vehicle 32 to the desired destination. Preferably, the navigation system 20 displays turn-by-turn instructions on display 24 along with corresponding audible turn-by-turn instructions via speaker 27, guiding the driver to the desired destination. The navigation system 20 stores turn-by-turn and other instructions and phrases in several different languages in the storage 28 and/or RAM 23.

The navigation system 20 further includes a removable media reader 44 connected to the CPU 22 for reading a portable, removable storage media 46, such as a floppy disk, a CD ROM, a card with a magnetized strip or a bar code, a memory chip (such as RAM, ROM, EEPROM, etc), or any other magnetic, electronic, or optical or other storage media. The reader 44 sends data from media 46 to the CPU 22.

As will be described in more detail below, the programmed (or pre-programmed) removable storage media 46 includes data which is used by the navigation system 20 in its operation and/or a code or codes which enable one or more functions of the navigation system 20. The removable media 46 includes data utilized by the navigation system 20, such as pre-stored routes, destinations, guided multimedia tours (explained below) or additional information regarding the routes or destinations or points of interest along the route. The removable media 46 further includes an indicator of which of the previously stored languages the navigation system 20 should use to generate the audible turn-by-turn instructions or, if necessary, also include the audio data, for generating the audible route guidance and other instructions in a human language other than those previously stored on CPU 22, such as German, French, Spanish, Japanese, etc.

At a location remote from the vehicle 32 is a programming station 50 including an input device, such as a keyboard and/or mouse 52, but alternatively including a touch screen display, microphone, keypad, etc. The programming station 50 further includes a CPU 54 including or connected

to a removable storage media writer 56 for writing information to the removable storage media 46. The CPU 22 and CPU 54 include appropriate software programmed to perform the functions described herein. One of reasonable skill in the art would be able to create the necessary programming for the CPUs 22, 54 to operate and perform these functions.

The programming station 50 is capable of selectively writing (or enabling) all of the information described above on the removable media 46 as determined by the user input device 52 and CPU 54. Alternatively, some removable media 46 may be preprogrammed to incorporate some or all of the above information. The programming station 50 is preferably located at a rental car agency, at which the vehicle 32 is one of the rental cars available. Via a graphical interface at the programming station 50, the operator can selectively add data to the removable data 46 of the types described above. The operator can select via the input device 52 a language for the audible instruction data, the time period or dates for the navigation system 20 to be enabled, the geographic areas for which to enable the navigation system 20, predetermined routes, points of interest and/or destinations to be traveled by the driver of the vehicle 32. The data may include additional information, including audible and/or multimedia annotations regarding points of interest and/or destinations along an intended route. The data may further include routes and multimedia annotations for guided multimedia tours.

Similar or identical programming stations 50 may also be provided at selected locations convenient to consumers. Alternatively, programming stations 50 may be located at a central location accessible via the telephone or Internet in which case the removable media 46 could be shipped to the user's location. The programming station 50 could alternatively be a user's home computer in which case the additional data could be obtained via the Internet or via a remote connection.

The navigation system 20 further includes a transceiver 48, such as (or similar to) a cellular phone, PCS, satellite phone, RF, microwave or other wireless communication system. The transceiver 48 is connected to the CPU 22 which includes the appropriate communication software, such as Internet software. The transceiver 48 communicates with a plurality of complementary transceivers 64 (one shown) such as cell towers or a satellite. The transceiver 64 is connected via telephone lines, wireless links (such as cell towers or satellites), and/or the Internet to an Internet server 62 which in turn is connected via telephone lines, wireless link and/or the Internet to a central station 60, generally comprising a CPU, preferably with graphical user interface and mass storage (not shown). In general, information is exchanged between the central station 60 and the navigation system 20 via the transceivers 64, 48. Details of the information exchanged will be described below; however, one of ordinary skill in the art could provide the appropriate software to implement the functions described.

Referring to FIG. 2, central station 60 stores a plurality of accounts 62, each having a plurality of associated ads 64, which comprise multimedia annotations (such as text, graphics, audio, MPEG (or similar), or other multimedia files). Each of the ads 64 is associated with an account 62 corresponding to an advertiser. Each advertiser may be associated with a plurality of ads 64. Each ad 64 may be further linked to additional information 68 regarding the advertiser. For example, a restaurant may include as additional information 68 its menu, prices, etc.

Each ad 64 is associated with a tally 66 indicating the number of times the ad 64 was displayed and the number of

times the additional information 68 is accessed. Preferably, the central station 60 also tracks the average amount of time each ad is displayed, number of times the user was routed to the ad's associated destination after seeing the ad 64 and other statistical information. Each ad 64 (within an account) may be associated with the same, some of the same, or different additional information 68. There need not be an exclusive one-to-one association between the ads 64 and the additional information 68. Only a few ads 64 and additional information 68 are shown; however, many more would be used. Preferably, the ads 64 are associated only with information associated with the same account 62, i.e., preferably ads 64 in one account 62 are not associated with additional information 68 in a different account 62.

Each account 60 further includes a charge 70 indicating an amount to charge an advertiser associated with the account 62 based, at least in part, on the tallies 66. For example, there may be a fixed fee for each tally 66. The field 70 represents the total charge associated with that advertiser account 62 for providing the advertising service. Periodically, central station 60 transmits the field 70 to the associated advertiser for payment. Each ad 64 also includes location information 72, which may comprise a plurality of locations. Alternatively, or in addition, the additional information may include location information 74, which again could include multiple locations.

A first screen 80 to be displayed on the display 24 is shown in FIG. 3. The first screen 80 includes a plurality of icons 82 which may be selected by the user utilizing the input device 26 (FIG. 1). Each of the icons 82 is associated with a plurality of pre-stored destinations stored in database 29 or options for entering destinations. Icon 82a (shown selected) is associated with "points of interest." Screen 80 further includes an ad portion 86 in which ads stored on CPU 22 and/or storage 28 are displayed periodically. These are the ads 64 from the central station 60 (FIG. 2) or stored locally on the mass storage 28. The first screen 80 displays only ads 64 associated with a location 72 (FIG. 2) within a predetermined distance from the current location of the vehicle 32 as determined by the navigation system 20. A startup screen also displays ads 64 which are locally stored on the mass storage 28. Statistical usage information as described above may also be kept by the navigation system 20 and periodically sent to the central station 60. The user can also select to be routed (via turn-by-turn instructions) to the location associated with any ad 64, such as the location of the restaurant, etc.

Utilizing the input device 26, the user can select the currently displayed ad 64, (which is a multimedia annotation) to obtain additional information 68 associated with the ad 64. Preferably, the additional information 68 would occupy most or all of the screen 24. Upon request for additional information 68, the transceiver 48 indicates to the central station 60 (via 64, 62) that the additional information 68 has been requested. The central station 60 then increments the associated tally 66 and updates the total charge 70 associated with the account 62. If the additional information 68 associated with the ad 64 is not already stored on CPU 22 or storage 28, the transceiver 48 sends a request to the central station 60, which then transmits, via transceiver 48, the additional information 68.

The additional information 68 may comprise text, graphics and/or multimedia presentations associated with the ad 64. For example, for an ad 64 associated with a restaurant, the additional information 68 may comprise menu, prices or other additional information. The additional information 68 presented based upon a request in response to a selected ad

64 may also depend upon the current location of the vehicle 32 as determined by the vehicle navigation system 20. Different additional information 68 may be presented based upon the current location of the vehicle 32 by comparing the current location of the vehicle to the location information 74 associated with the additional information 68.

Alternatively, the CPU 22 and/or storage 28 may store additional information 68, particularly previously retrieved additional information 68. The CPU 22 and/or storage 28 may also temporarily keep usage information such as number of times the ads 64 are each displayed, number of accesses to the information 68, viewing time for each ad 64, average viewing time for ads 64, whether the user was actually routed to the location associated with the ad 64 after seeing the ad 64 and other statistical usage information. This information is periodically transmitted to the central station 60 via the wireless links, or via the removable media 46 (particularly in the context of a car rental agency).

Upon selection of the points of interest icon 82a in FIG. 3, the user would be presented with a list of selections for types of points of interest, such as airports, gas stations, restaurants, etc., as is known. Upon selecting a type of points of interest, such as "restaurant" a second screen 90 is displayed on display 24, as shown in FIG. 4. Names of specific points of interest (in this example, restaurants) are displayed in name fields 92a-f. More names can be selected by paging the display 24 down. Name fields 92 for which additional information 68 (FIG. 2) is available include such an indication, such as an icon 94 adjacent the name field 92. The second screen 90 also includes an ad field 96 in which the ads 64 are periodically displayed. In the second screen 90, since a type of points of interest has been selected (in this example, restaurants), only ads 64 which are associated with that type of points of interest are displayed in ad field 96. Additional information regarding the displayed ad 64 can be obtained in a manner identical to that described in ad field 86 of a first screen 80 (FIG. 3). The display of the ad 64 is also based upon the current location of the vehicle 32 as determined by the navigation system 20 identical to that described with respect to first screen 80 in FIG. 3. The user can also select to be routed to the location associated with the ad 64.

The navigation system 20 may normally be in a locked mode in which at least one function of the navigation system 20 is disabled. For example, in the locked mode, navigation system 20 may not provide any useful function at all, or the navigation system 20 may provide no indication of the position of the vehicle 32 via the display 24, or the CPU 22 may not determine the position of the system, or other ways in which the navigation system 20 may be rendered disabled or useless. It should be noted that the vehicle 32 itself is not disabled. The vehicle 32 and all of its other functions can be operated normally and safely, without the benefit of the navigation system 20 while the navigation system 20 is in a completely disabled locked mode.

Additionally, the navigation system 20 may include locked modes where only some functions are disabled, but the navigation system still calculates position and provides route guidance information in at least some geographic areas. For example, the database 28 may include a plurality of geographic areas (such as nine) only one or a few of which are normally enabled, such as when the system 20 is initially installed into the vehicle 32. The code in the removable media 46, after being received by CPU 22, enables selected additional geographic areas in the database 28. Alternatively, this code could be entered via the input device 26. Since the navigation system 20 includes its own



source for current time, from the GPS receiver **34**, the code may enable a geographic area or other function for a limited time. For example, based upon data in the CPU **22**, the code, whether received via the input device **26** or the removable media **46**, could indicate that the specified geographic area or other function be enabled for a predetermined time period, such as a few days or one week. Alternatively, the code could indicate that the geographic area or other function be enabled from a specified start time and date to a specified ending time and date. Preferably, if the code is entered via the input device **26**, the code is an alphanumeric code entered sequentially by the user. The code may indicate directly or indirectly via a look-up table or encrypted algorithm, a start time and/or ending time during which the navigation system **20** or at least one function of the navigation system **20** is enabled. Preferably, each the codes are unique to each navigation system **20**, such that a code will only work for a specific navigation system **20**, which may be identified by a serial number or other unique identifier.

The operation of the navigation system **20** as it may be utilized in a rental car agency will be described with respect to FIG. **1**. The programming station **50** is located at the rental car agency and the vehicle **32** is one of the associated rental vehicles. Preferably the rental car agent programs the removable media **46** at the programming station **50** based upon the renter's requests and needs. The programming station **50** programs the removable media **46** to include the code for enabling the navigation system **20** in any or all of the ways described above. Further, since the user most likely has at least one known intended destination, this destination, or even the entire route, can be stored on the removable media **46**. The user may also wish to travel to additional destinations, such as other points of interest, which may also be stored on the removable media **46**. For example, the user's hotel, several entertainment venues and the location of the rental car agency at which the programming station **50** is located are stored on removable media **46**.

The programming station **50** may also store "tours" on the removable media **46**. The tours comprise predetermined routes with a plurality of destinations along the route, such as points of interest. At least some of the points of interest are linked to text, graphic and/or multimedia files relating to that location which are also stored on the removable media **46**. The removable media **46** may further include audio data, such as audible route guidance and other instructions in a human language other than that previously stored on CPU **22**. It should be understood that the removable media **46** could include any one or any combination or all of this information.

The car rental agent (or user) then takes the removable media **46** to the vehicle **32** and loads it into the reader **44** in a manner appropriate to the specific technology (i.e., CD, DVD, magnetic, etc. as described above). The reader **44** retrieves the code from the removable media **46** and sends it to the CPU **22** for authentication. The CPU **22** evaluates the code and determines whether to enter the enabled mode and what features to enable (for example, which geographic areas). If the code is for a specific time period, the CPU **22** may determine the start time and ending time and verify that the enabled time has begun but has not passed.

If the CPU **22** determines that a valid current code is obtained, the navigation system **20** is enabled. A power up or start up screen is first displayed on the display **24**. The start up screen may include an ad **64**, which may or may not be based upon the current location of the vehicle **32**. Statistical, usage and billing information regarding this ad **64** on the start up screen would be kept by the CPU **22** and/or the central station **60** as described above.

The CPU **22** retrieves a first destination from the removable media **46**. If the route to the first destination was not previously stored on removable media **46**, the CPU **22** calculates its own route via the database **28** and appropriate route guidance software. The user is then guided to the first destination via turn by turn instructions on the display **24** and speaker **27**. The CPU **22** may also retrieve the audio data from the removable media **46** and generate audible turn by turn instructions based upon the audio data, in a language appropriate for the intended user, which may be a language different than that previously stored on the navigation system **20**. The user, via the user input device **26** and display **24**, may select other prestored routes and/or destinations from the removable media **46**. Of course, the user can always choose to utilize the navigation system **20** in the normal, known manner of selecting points of interest, entering addresses, intersections, etc.

When the user chooses to conduct one of the "tours" stored on the removable media **46**, the navigation system **20** retrieves the starting point location of the route and first guides the user to the starting point in the normal manner. Alternatively, the user can begin the tour at any point on the tour route. The navigation system **20** then guides the user along the tour route. As the navigation system **20** approaches, reaches or passes selected locations along the tour route, the CPU **22** retrieves text, graphics, audio or other multimedia annotations providing information regarding that location. For example, the tour may guide the user to historical points of interest in the area. The additional information stored on removable media **46** will be provided by the navigation system **20** on display **24** and via audio, information regarding that location, such as historical events or other facts about the location, etc. Each of the multimedia annotations are associated with a location. The CPU **22** presents each multimedia annotation when the current location of the vehicle **32** as determined by the navigation system **20** is the same as, or within a predetermined distance from, the associated location. Each tour route may actually comprise a series of sequentially displayed connected routes, i.e. each destination of one route is an origin for the next route and each destination (or origin) is linked to a multimedia annotation.

The user may also enter information, such as text or audio, via the user input device **26** and associate that information with specific locations. The information and the location or locations with which the information is associated is stored on CPU **22** and/or storage **28**. For example, the user may store several "to do" lists and associate these lists each with a location, locations or type of location (e.g., grocery store, customer location, vehicle service station, etc.). Other information entered by the user via the input device **26** could also be associated with a location or locations, for example, contact names, account information, or other information each associated with a customer or account of the user. When the user travels to a location associated with such information, that information is presented to the user. For example, when the user arrives at the customer's location, the display **24** will display the information associated with that customer.

In view of the above descriptions, many variations of the present inventions should be apparent. For example, information from the programming station **50** may also be transmitted to the navigation system **20** via the transceivers **64**, **48**, or could alternatively be transmitted via a temporarily connected hard wire connection. The programming station **50** and central station **60** could be the same computer. All communication between the CPU **22** and programming

station/control station **50,60** could take place via the removable media **46**.

In accordance with the provisions of the patent statutes and jurisprudence, exemplary configurations described above are considered to represent a preferred embodiment of the invention. However, it should be noted that the invention can be practiced otherwise than as specifically illustrated and described without departing from its spirit or scope.

What is claimed is:

**1.** A method for communication information in a vehicle navigation system including the steps of:

- (a) determining a vehicle position relative to a database of roads;
  - (b) selecting an ad based upon the vehicle position;
  - (c) displaying the selected ad in a first portion of a screen; and
  - (d) displaying route guidance information in a second portion of the screen.
- 2.** The method of claim **1**, further including the steps of:
- (e) associating each of a plurality of ads, including said selected ad, with at least one of a plurality of categories;
  - (f) selecting one of the plurality of categories, wherein said step (b) limits the selection to ads associated with said selected category.

**3.** The method of claim **1**, further including the step of:

- (e) requesting route guidance instructions to a destination associated with said selected ad in response to said step (c); and
- (f) displaying route guidance instructions to said destination in response to said step (e).

**4.** The method of claim **1**, further including the steps of:

- (e) requesting additional information in response to said step (c); and
- (j) displaying additional information associated with the ad displayed on the first portion of the screen in response to said step (e).

**5.** The method of claim **4**, wherein said additional information includes a restaurant menu.

**6.** The method of claim **4**, wherein said additional information is transmitted via a wireless signal.

**7.** A vehicle navigation system comprising:

- at least one position determining device;
- a processor determining a position of the system based upon data received from said at least one position determining device;
- an output device for indicating the position of the system as determined by the processor;
- an input device connected to the processor, said navigation system including a locked mode in which at least one function of the navigation system is disabled, said navigation system enabling said at least one function upon entry of a code via the input device.

**8.** The navigation system of claim **7**, wherein said input device is a user input device.

**9.** The navigation system of claim **8**, wherein the code is an alphanumeric code entered sequentially by the user input device.

**10.** The navigation system of claim **7**, wherein said at least one function includes a database of roads in a selected first geographic area.

**11.** The navigation system of claim **10**, wherein said navigation system is enabled to access a database of roads in a second geographic area but not said first geographic area when in said locked state.

**12.** The vehicle navigation system of claim **7**, wherein said vehicle navigation system provides no indication of the position of the system via the output device when in said locked mode.

**13.** The vehicle navigation system of claim **7**, wherein said processor does not determine the position of the system when in said locked mode.

**14.** The vehicle navigation system of claim **13**, wherein the vehicle is not disabled in said locked mode.

**15.** The vehicle navigation system of claim **7**, wherein said code enables said vehicle navigation system for a predetermined time period.

**16.** The vehicle navigation system of claim **15**, wherein said code indicates a starting time and an ending time to the navigation system for the enabled state.

**17.** The vehicle navigation system of claim **7**, wherein said code indicates a selected geographic area to be enabled.

**18.** The vehicle navigation system of claim **7**, further including a key which is physically portable relative to the processor, said key communicating said code to said navigation system via the input device.

**19.** The vehicle navigation system of claim **18**, wherein said key indicates specific geographic areas to be enabled.

**20.** The vehicle navigation system of claim **18**, wherein said key indicates a selected time period for the navigation system to be enabled.

**21.** The vehicle navigation system of claim **18**, wherein said key is programmable.

**22.** The vehicle navigation system of claim **18**, wherein said key includes route guidance information.

**23.** The vehicle navigation system of claim **18**, wherein said output device includes a speaker generating audible route guidance instructions, said key further including language data, said language data enabling said navigation system to generate said audible route guidance instructions in an additional language.

**24.** A vehicle navigation system comprising:

- at least one position determining device;
- a processor determining a position of the system based upon data received from said at least one position determining device and indicating said position of the system;
- removable media storing data; and
- said navigation system operating based upon said data from said removable media.

**25.** The vehicle navigation system of claim **24** wherein said data includes a plurality of geographic locations.

**26.** The vehicle navigation system of claim **24** further including a database of roads, said data including a plurality of geographic locations relative to said database.

**27.** The vehicle navigation system of claim **24** further including a programming computer including a user input device at a location remote from said navigation system, said programming computer storing said data on said removable media based upon input from said user input device.

**28.** The vehicle navigation system of claim **24** wherein said data includes a code for enabling at least one function of said vehicle navigation system.

**29.** The vehicle navigation system of claim **28** wherein said at least one function includes a database of roads in a selected first geographic area.

**30.** The navigation of system claim **28** wherein said vehicle navigation system provides no indication of the position of the system if not enabled.

**31.** The vehicle navigation system of claim **24** wherein said data includes audible instruction data, wherein said output device provides audible route guidance instructions based upon said audible instruction data.

11

32. A method for communicating information in a vehicle navigation system including the steps of:

- (a) determining a position of the system relative to a database of roads;
- (b) associating each of a plurality of ads with at least one of a plurality of categories;
- (c) selecting one of the plurality of categories;
- (d) selecting one of said ads associated with said selected category based upon said position; and
- (e) displaying the selected ad.

33. The method of claim 32 further including the step of: sending a signal to a remote location remote from the position indicating the selection made in said step (d).

34. The method of claim 33 further including the step of tallying the selections of each of the plurality of ads at the remote location.

35. The method of claim 34 further including the step of calculating a charge based upon said step of tallying.

36. The method of claim 32 further including the step of determining the time that the ad is displayed.

37. The method of claim 36 further including the step of sending a signal from the remote location to the system altering the display of the ad.

38. The method of claim 37 wherein said step (a) is performed utilizing a user input device associated with the vehicle navigation system.

39. The method of claim 32 further including the step of sending a signal from a remote location to the system indicating that at least one of said ads should not be displayed.

40. A method for operating a vehicle navigation system including the steps of:

- (a) entering information into the vehicle navigation system;

12

(b) storing said information on the vehicle navigation system;

(c) associating the information with at least one geographic location;

(d) determining a position of the navigation system; and

(e) recalling the information based upon said steps (d) and (c).

41. A method for communicating information in a vehicle navigation system including the steps of:

(a) associating each of a plurality of annotations with each of a plurality of locations along a route;

(b) moving a vehicle along said route;

(c) determining a position of the vehicle relative to the route and the plurality of locations during said step (b);

(d) comparing the position of the vehicle as determined in step (c) with the plurality of locations; and

(e) displaying each of the plurality of annotations based upon said step (d).

42. The method of claim 41 further including the step of:

(f) storing the route in the navigation system prior to said step (b); and

(g) guiding the vehicle along the route based upon the determined position of the vehicle as determined in said step (c).

43. The method of claim 42 wherein the route is a tour including at least three of the locations each having an associated one of the annotations.

44. The method of claim 43 wherein the annotations are multimedia annotations.

\* \* \* \* \*

# **EXHIBIT B**



US006163269A

**United States Patent** [19]  
**Millington et al.**

[11] **Patent Number:** **6,163,269**  
[45] **Date of Patent:** **Dec. 19, 2000**

[54] **NAVIGATION SYSTEM WITH ANTI-ALIAS MAP DISPLAY**

|           |         |                     |         |
|-----------|---------|---------------------|---------|
| 5,065,144 | 11/1991 | Edelson et al. .... | 340/703 |
| 5,140,315 | 8/1992  | Edelson et al. .... | 345/136 |
| 5,365,251 | 11/1994 | Denber .....        | 345/136 |
| 5,742,277 | 4/1998  | Gossett et al. .... | 345/136 |

[75] Inventors: **Jeffrey Alan Millington**, Rochester Hills; **Anthony Albert Slominski**, Harrison Township, both of Mich.

**FOREIGN PATENT DOCUMENTS**

[73] Assignee: **Magellan DIS, Inc.**, Rochester Hills, Mich.

|         |         |           |
|---------|---------|-----------|
| 4013851 | 11/1991 | Germany . |
| 3211591 | 9/1991  | Japan .   |
| 6034382 | 2/1994  | Japan .   |

[21] Appl. No.: **09/160,068**  
[22] Filed: **Sep. 24, 1998**

*Primary Examiner*—Jeffery A. Hofsass  
*Assistant Examiner*—John Tweel, Jr.  
*Attorney, Agent, or Firm*—Carlson, Gaskey & Olds

**Related U.S. Application Data**

|      |                                                          |
|------|----------------------------------------------------------|
| [60] | Provisional application No. 60/084,231, May 5, 1998.     |
| [51] | <b>Int. Cl.<sup>7</sup></b> ..... <b>G08B 5/00</b>       |
| [52] | <b>U.S. Cl.</b> ..... <b>340/815.4</b> ; 345/136         |
| [58] | <b>Field of Search</b> ..... 340/815.4; 345/136, 345/147 |

[57] **ABSTRACT**

A navigation system includes a display displaying a map of roads from a road database. The navigation system utilizes a palette of colors to display the road and background on the display. The palette preferably includes a plurality of shades for each of a plurality of colors to be displayed including the background color and the road color. The roads on the display are preferably anti-aliased by indexing a different intensity of the shade of the object based upon the relative position of the pixel and an ideal object area.

[56] **References Cited**

**U.S. PATENT DOCUMENTS**

|           |        |                    |         |
|-----------|--------|--------------------|---------|
| 4,591,844 | 5/1986 | Hickin et al. .... | 340/728 |
|-----------|--------|--------------------|---------|

**11 Claims, 1 Drawing Sheet**

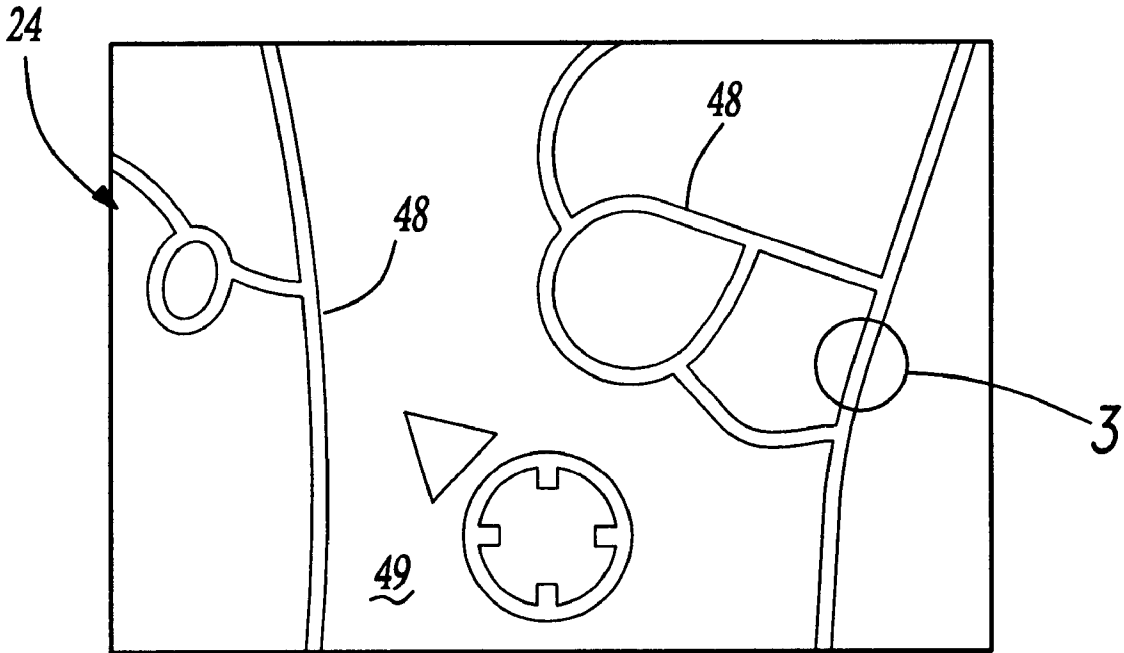

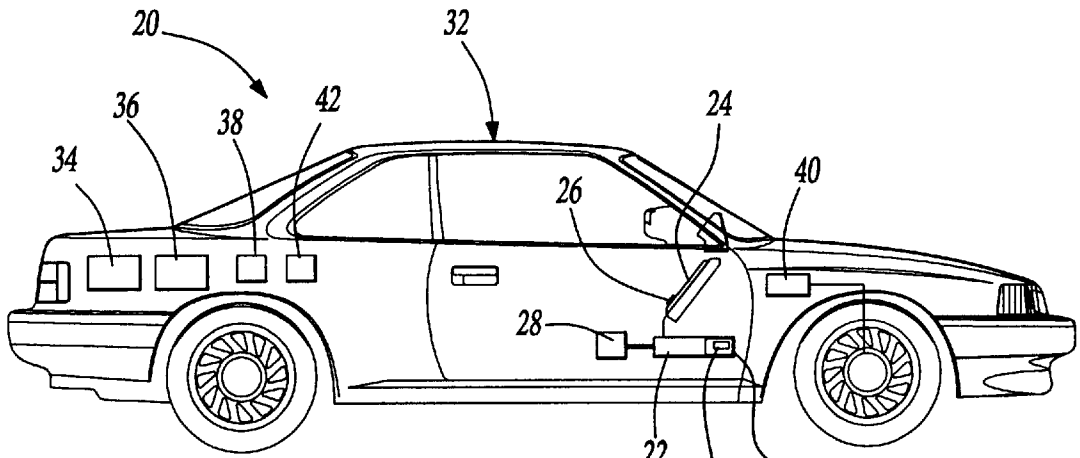

Fig-1

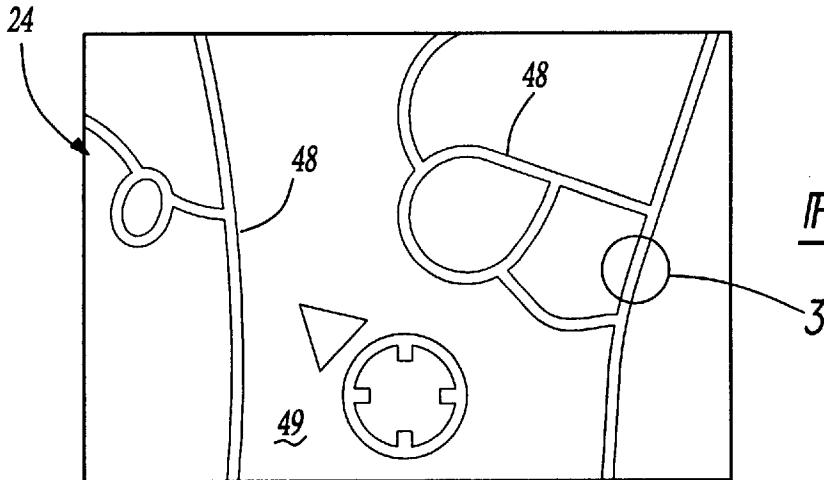

Fig-2

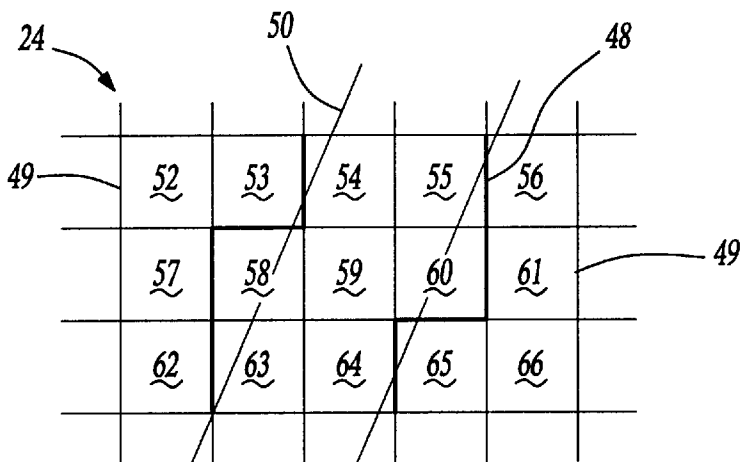

Fig-3

## NAVIGATION SYSTEM WITH ANTI-ALIAS MAP DISPLAY

This application claims priority to U.S. provisional application Serial No. 60/084,231, filed May 5, 1998.

### BACKGROUND OF THE INVENTION

The present invention relates generally to in vehicle navigation or route guidance systems, and more particularly to an improved display for such a system.

Navigation systems include a graphical user interface having a display which displays the current position of a vehicle on a map. The display of the roads on the map in particular may include curved or diagonal lines which may appear jagged, due to the limited resolution of the display. Although increasing the resolution of the display would alleviate this problem, this would also increase the cost of the display and the power required for the processor handling the display.

It is known to use anti-aliasing on home computer displays to reduce the jagged appearance of lines which are not perfectly vertical or horizontal, i.e. perfectly aligned with the columns or rows on the display. In the known anti-aliasing technique for computer displays each pixel includes a red, green and blue numerical value which precisely defines the color of that pixel. A displayed line formed as a plurality of discrete pixels is compared mathematically to the ideal desired line. Pixels which are not completely on the ideal line are evaluated mathematically relative to the ideal. For example, one pixel on a line may be half inside and half outside the ideal line. Half of that pixel would ideally be the color of the line or object and the other half of that pixel would ideally be the color of the background. The color of that pixel is altered to a color which is a weighted average of the color of the line and the color of the background. The weighting of the color is proportional to the amount that the pixel is inside versus outside the ideal. For example, if the pixel were 80 percent in the ideal line, the red, green and blue values for that pixel would each be 80 percent of the values for the line plus 20 percent of the values for the background color.

In order to reduce computation time and power, the navigation system may use paletted colors, in which there are only a limited number of colors available at any one time. Each of the palette's colors can be any color. Each pixel in the display includes an index to the color palette indicating the color that the pixel is to be displayed. The color that is the weighted average of the line or object in background is probably not available. As a result, the bordering pixels in a line or object on a navigation system display cannot be anti-aliased according to the known technique.

### SUMMARY OF THE INVENTION

The navigation system of the present invention provides a map display which utilizes anti-aliasing with paletted colors. The palette includes a plurality of colors, each having a plurality of shades or intensities. The road lines are displayed in one color against a background of a different color.

Each pixel in a road line is mathematically compared to the shape of the ideal road line and then displayed at an appropriate shade of the color. If the pixel is completely within the ideal road line the pixel is displayed at the highest intensity of the road line color. The intensity of that color is reduced proportionally for pixels which are not completely

within the ideal. Preferably, a color which is mathematically determined to be less than a predetermined threshold would be switched to the background color rather than reduced further in intensity.

### BRIEF DESCRIPTION OF THE DRAWING

The above, as well as other advantages of the present invention, will become readily apparent to those skilled in the art from the following detailed description of a preferred embodiment when considered in the light of the accompanying drawing in which:

FIG. 1 is a schematic of the navigation system of the present invention;

FIG. 2 is a map displayed by the display of FIG. 1; and  
FIG. 3 is an enlarged view of a area 3 of FIG. 2.

### DETAILED DESCRIPTION OF THE PREFERRED EMBODIMENT

The navigation system 20 of the present invention is shown schematically in FIG. 1. The navigation system 20 includes a CPU 22 connected to a display 24, such as a high resolution LCD or flat panel display. The CPU 22 is also connected to an input device 26 such as a mouse, keyboard, key pad, microphone or remote device. Alternatively, the display 24 can be a touch screen display. The navigation system 20 further includes a storage device 28, such as a hard drive 28 or CD ROM, connected to the CPU 22. The storage device 28 contains a database including a map of all the roads in the area to be traveled by the vehicle 32 and may contain the software for the CPU 22, including the graphical user interface, route guidance, operating system, position-determining software, etc.

The navigation system 20 preferably includes position and motion determining devices, such as a GPS receiver 34, a gyroscope 36, a compass 38, a wheel speed sensor 40 and an orthogonal multiple axis accelerometer 42 all connected to the CPU 22 (connections not shown for simplicity). Such position and motion determining devices are well known and are commercially available.

The navigation system 20 determines the position of the vehicle 32 relative to the database of roads utilizing the position and motion determining devices. The driver selects a destination relative to the database of roads utilizing the user input device 26 and the display 24. The navigation system 20 then displays turn-by-turn instructions to the driver to guide the driver to the desired destination from the present position.

In the present invention, the CPU 22 includes memory 44, preferably RAM or flash RAM, storing the necessary software and data as well as a palette 46 of colors which can be displayed on the display 24 at one time. The color palette 46 is generally a known technique for displaying colors in computers and in navigation systems. Preferably, the palette 46 contains 256 colors including 5 colors of 16 shades each.

The operation of the display 24 will be described with respect to displaying maps, as shown in FIG. 2, for illustration purposes. It should be recognized that the same technique could be used for displaying icons, menus and other objects on the display 24. FIG. 2 shows the display 24 of FIG. 1 displaying a map of roads 48 displayed against a background 49.

FIG. 3 illustrates a portion of a road 48 on display 24 from FIG. 2, compared to the ideal road 50. The road 48 shown in FIG. 3 could be alternatively be a portion of text, icon or other displayed object from FIG. 2. In a manner similar to

3

a well known anti-aliasing algorithm, the pixels in the road 48 are compared with ideal road 50. In the present invention using paletted colors the road 48 is displayed in a first color adjacent a background 49 of a second color. Each pixel 53-55, 58-60 and 63-65 is mathematically compared to the ideal road 50 and then displayed at an appropriate shade of the color. Each of the 5 colors has 16 shades available, 0-15, with 15 having the highest intensity and 0 having the lowest intensity. If the pixel is completely within the ideal road 50, the pixel is displayed at shade level 15, the highest intensity of the first color. The intensity of that color is reduced proportionally for pixels which are not completely within the ideal road 50. Preferably, a pixel for which it is mathematically determined should be less than level 4 would be simply switched to the color of the background 49 rather than reduced in intensity further.

Referring specifically to FIG. 3, pixels 52, 56, 57, 61, 62 and 66 are 0% in the ideal object 50 and are therefore 100% the color of the background 49. Similarly, pixel 59 is 100% within the ideal and therefore has level 15 intensity for the first color of the road 48. Pixels 54 and 64 are approximately 95% within the ideal object and therefore preferably have a level 14 intensity of the first color of the road 48. Pixels 55 and 63 are approximately 75% within the ideal object 50 and are therefore preferably assigned level 13 intensity for the color of the road 48. Pixels 53, 58, 60 and 65 are less than 50% within the ideal object 50 and are therefore assigned the color of the background 49.

The navigation system 20 of the present invention provides a simple and efficient technique which improves the display of the roads. The overall appearance of the display 24 is improved without the need to increase the resolution of the display 24 or the power requirement of the CPU 22.

In accordance with the provisions of the patent statutes and jurisprudence, exemplary configurations described above are considered to represent a preferred embodiment of the invention. However, it should be noted that the invention can be practiced otherwise than as specifically illustrated and described without departing from its spirit or scope.

What is claimed is:

1. A method for displaying a map in a navigation system including the steps of:
  - a. providing a palette having a plurality of shades of each of a plurality of colors;
  - b. displaying each of a plurality of pixels at one of the plurality of colors;
  - c. displaying the map including a plurality of road lines; and
  - d. anti-aliasing the road lines utilizing the plurality of colors.
2. The method of claim 1 further including the steps of:
  - e. utilizing the plurality of shades in the palette to anti-alias the road lines; and
  - f. displaying the road lines as a first color of the plurality of colors against a background of a second color of the plurality of colors.

4

3. The method of claim 2 further including the steps of:
  - g. comparing each of the pixels to an ideal road line; and
  - h. varying an intensity of the color of the pixels based upon said step g.

4. The method of claim 3 wherein said intensity of the color is varied in said step h by selecting one of the shades of the first color and displaying different pixels in the road lines as different shades of the first color.

5. The method of claim 4 further including the step of reducing the intensity of the first color of the pixel proportionally to a portion of the pixel not lying within the ideal road line.

6. The method of claim 5 further including the steps of: displaying at least one of the pixels at the background color based upon a threshold portion of one of said pixels not being within the ideal road line.

7. A display system for a navigation system comprising: a palette of a plurality of intensities of each of a plurality of colors;

an array of pixels, each selectively illuminated at one of said intensities of said colors;

said pixels selectively illuminated to display a road line of a first color of said plurality of colors against a background of a second color of said plurality of colors, said pixels comprising said road line being displayed at different intensities of said first color from said palette.

8. The display system of claim 7 wherein pixels comprising said road line are compared to an ideal road line, said intensities of said pixels being varied based upon said comparison.

9. The display system of claim 8 wherein said pixels comprising said road line are displayed at varying intensities from said palette proportionally to the overlap of said pixels with said ideal road line.

10. The display system of claim 9 wherein pixels having overlap of said ideal line less than a predetermined threshold greater than zero are displayed at the color of the background.

11. A display system for a navigation system comprising: a palette of a plurality of intensities of each of a plurality of colors;

an array of pixels, each selectively illuminated at one of said intensities of said colors;

said pixels selectively illuminated to display a road line of a road color of said plurality of colors against a background color of said plurality of colors, said pixels comprising said road line being compared to an ideal road line, said pixels displayed at varying intensities of said road color from said palette based upon said comparison proportionally to the overlap of said pixels with said ideal road line and pixels having overlap of said ideal line less than a predetermined threshold greater than zero are displayed at the color of the background.

\* \* \* \* \*



# **EXHIBIT C**



US005878368A

**United States Patent** [19]  
**DeGraaf**

[11] **Patent Number:** **5,878,368**  
[45] **Date of Patent:** **\*Mar. 2, 1999**

- [54] **NAVIGATION SYSTEM WITH USER DEFINABLE COST VALUES**
- [75] Inventor: **Brent L. DeGraaf**, Canton, Mich.
- [73] Assignee: **Magellan DIS, Inc.**, Rochester Hills, Mich.
- [\*] Notice: This patent issued on a continued prosecution application filed under 37 CFR 1.53(d), and is subject to the twenty year patent term provisions of 35 U.S.C. 154(a)(2).

|           |         |                       |         |
|-----------|---------|-----------------------|---------|
| 5,465,088 | 11/1995 | Braegas .....         | 340/905 |
| 5,475,387 | 12/1995 | Matsumoto .....       | 701/25  |
| 5,513,110 | 4/1996  | Fujiita et al. ....   | 701/207 |
| 5,521,826 | 5/1996  | Matsumoto .....       | 701/208 |
| 5,568,390 | 10/1996 | Hirota et al. ....    | 701/209 |
| 5,612,882 | 3/1997  | LeFebvre et al. ....  | 701/209 |
| 5,638,280 | 6/1997  | Nishimura et al. .... | 701/209 |
| 5,684,704 | 11/1997 | Okazaki .....         | 701/201 |
| 5,712,788 | 1/1998  | Liaw et al. ....      | 701/209 |
| 5,717,593 | 2/1998  | Gvili .....           | 701/207 |
| 5,729,458 | 3/1998  | Poppen .....          | 701/25  |
| 5,731,978 | 3/1998  | Tamai et al. ....     | 701/201 |

*Primary Examiner*—Jacques H. Louis-Jacques  
*Attorney, Agent, or Firm*—Howard & Howard

- [21] Appl. No.: **713,627**
- [22] Filed: **Sep. 13, 1996**
- [51] **Int. Cl.**<sup>6</sup> ..... **G06G 7/78**
- [52] **U.S. Cl.** ..... **701/209; 701/201; 701/210; 73/178 R; 340/990; 340/988**
- [58] **Field of Search** ..... 701/200, 201, 701/202, 208, 209, 210, 212, 215, 216, 213, 211, 25, 26; 340/988, 990, 995; 73/178 R

[57] **ABSTRACT**

A navigation system permits the user to designate certain roads or areas to avoid when planning a route. The navigation system generally includes a database of road segments and a cost associated with the road segments, such as estimated time of travel across that road segment and estimated length of travel across that road segment. The navigation system determines a route from a selected beginning point to a desired destination by evaluating the cost of the road segments to be traveled in several potential routes and recommends the potential route having the lowest total cost. The user can selectively modify the cost of selected road segments to indicate a preference or avoidance of such roads. By increasing the cost of a road segment, the navigation system is less likely to recommend a potential route which includes that road segment. Similarly, by decreasing the cost of a selected road segment, the navigation system is more likely to recommend a potential route which includes that road segment.

- [56] **References Cited**
- U.S. PATENT DOCUMENTS**
- 4,086,632 4/1978 Lions ..... 701/210
- 5,031,104 7/1991 Ikeda et al. .... 701/209
- 5,220,507 6/1993 Kirson ..... 701/202
- 5,289,195 2/1994 Inoue ..... 701/208
- 5,311,173 5/1994 Komura et al. .... 701/208
- 5,369,588 11/1994 Hayami et al. .... 701/209
- 5,371,678 12/1994 Nomura ..... 701/210
- 5,406,490 4/1995 Braegas ..... 701/209
- 5,428,545 6/1995 Maegawa et al. .... 701/201

**26 Claims, 3 Drawing Sheets**

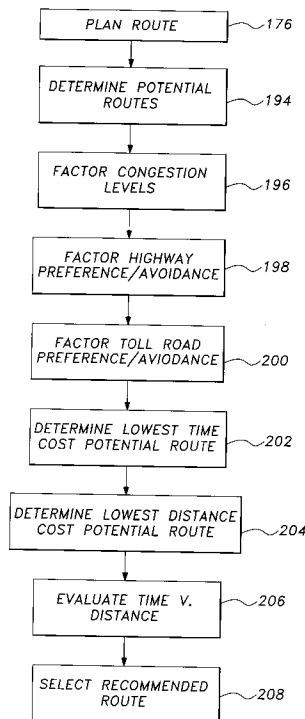

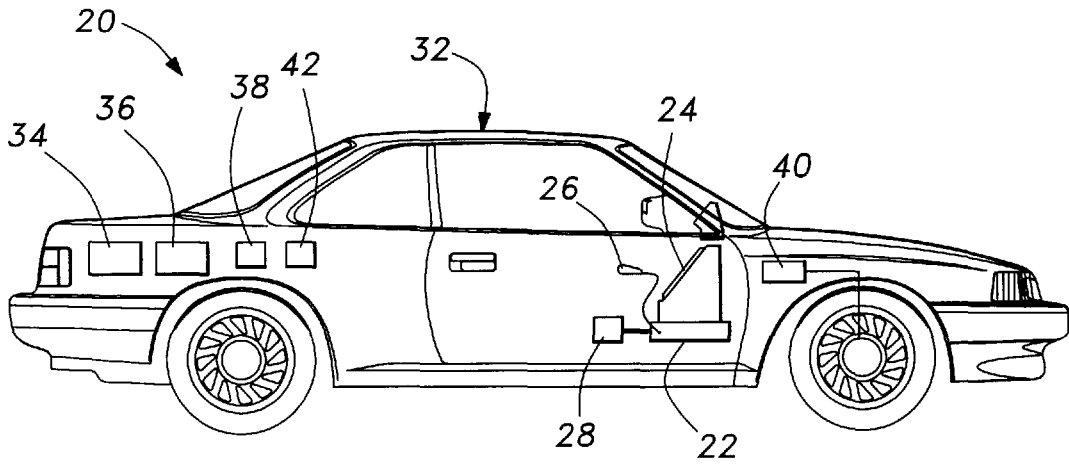

Fig-1

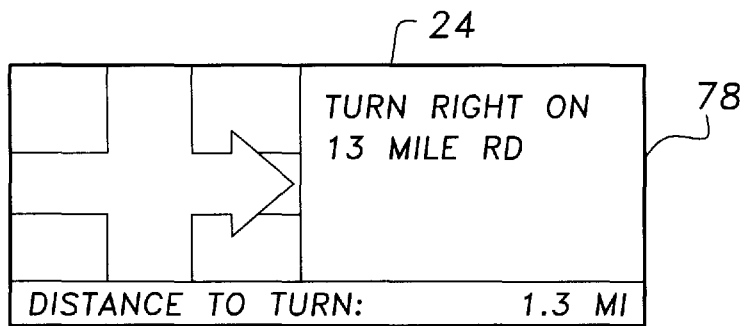

Fig-3

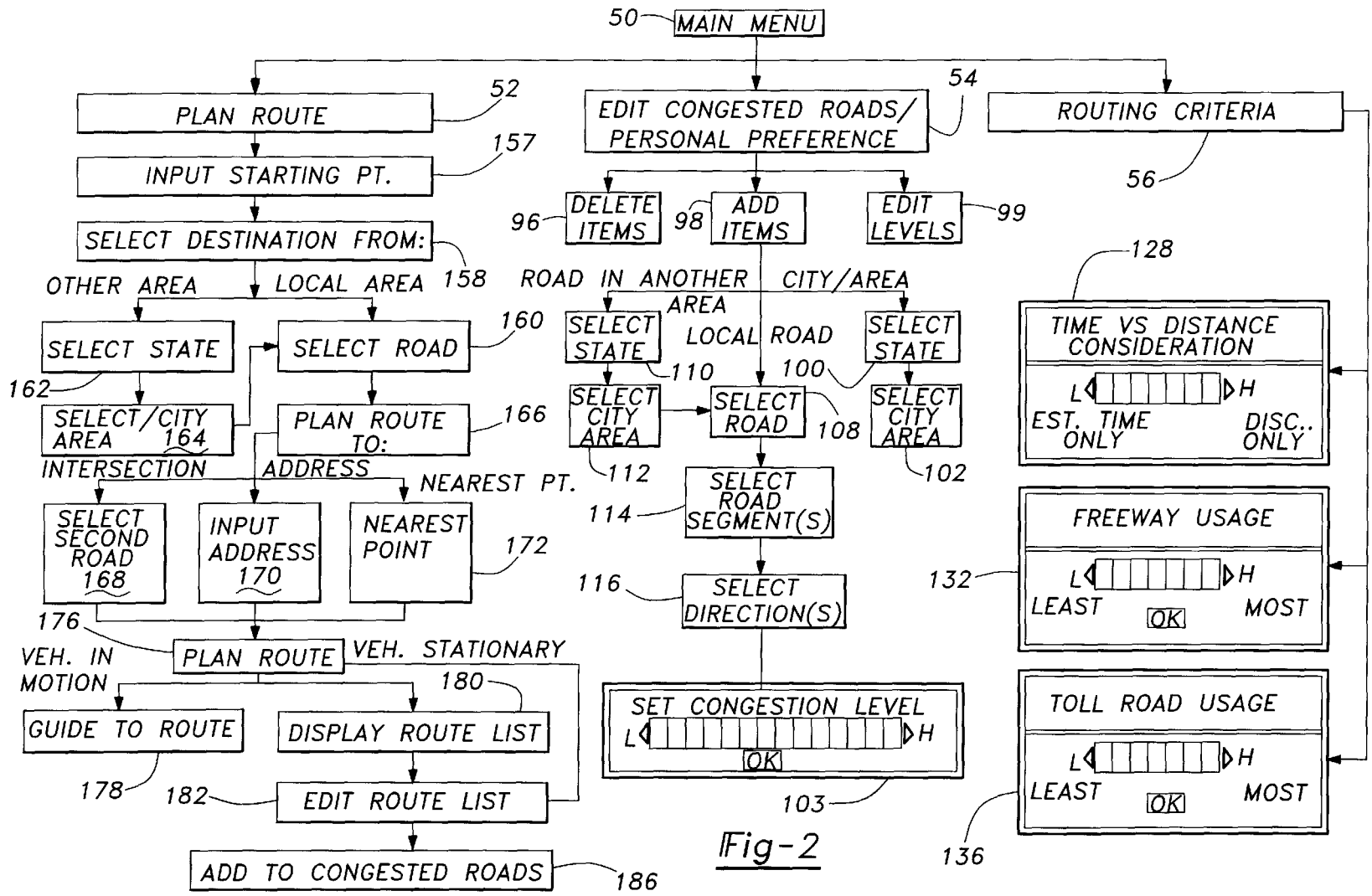

Fig-2

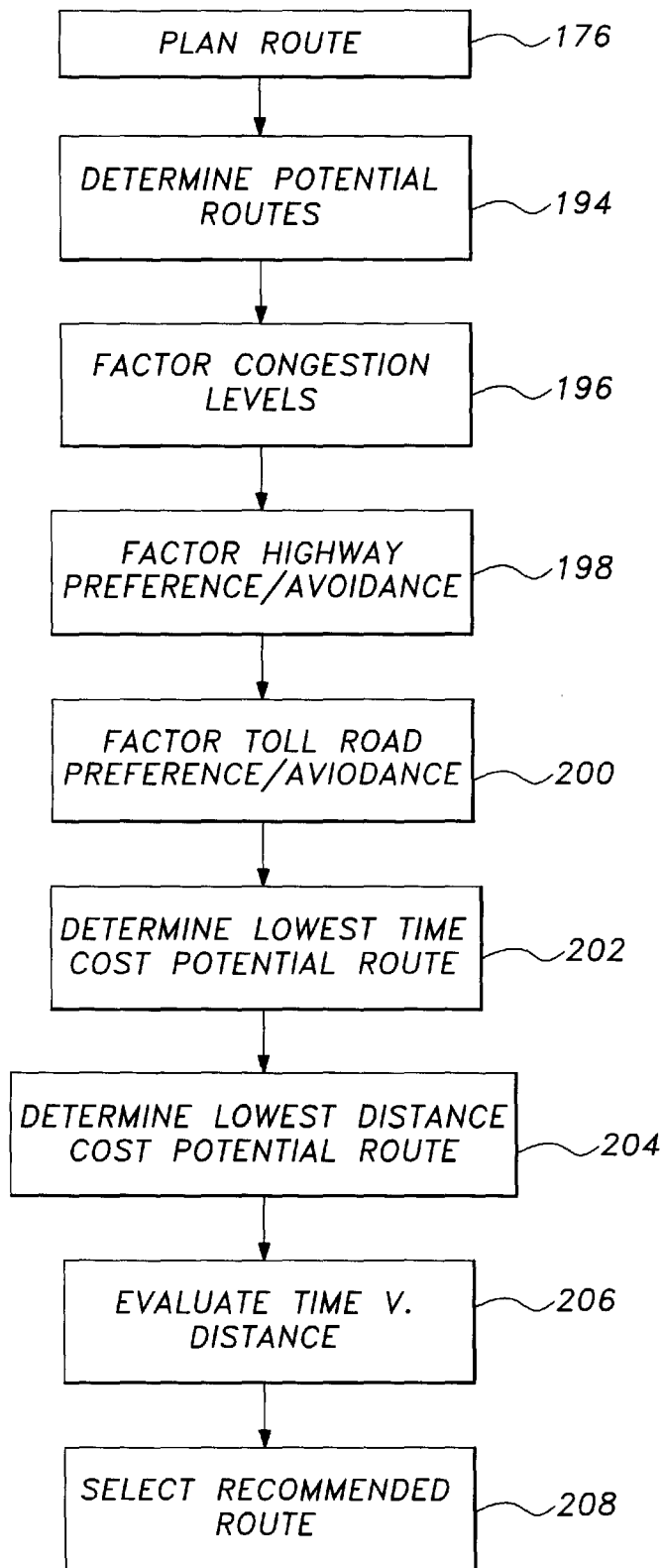

Fig-4

## NAVIGATION SYSTEM WITH USER DEFINABLE COST VALUES

### BACKGROUND OF THE INVENTION

This invention generally relates to navigation or route guidance systems that can be tailored to a user's particular wishes.

Navigation systems generally provide a recommended route from a starting point to a desired destination. Generally the starting point and desired destination are selected from a large database of roads stored in a mass media storage, such as a CD ROM, which includes the roads in the area to be traveled by the user. The navigation system can be located in a personal computer or can be installed in a vehicle. If the navigation system is installed in a vehicle, the starting point is typically the current position of the vehicle, which can be input from an associated positioning determining device, such as a GPS (Global Positioning System) receiver.

The navigation system determines a route from the starting point to the destination utilizing an algorithm well-known to those in the art and currently in use in many navigation systems. Usually there are many potential routes between the selected starting point and the desired destination. The navigation system selects a recommended route based upon certain "cost" values associated with each segment of road in the road database. These cost values include the length of the road segment and the estimated time of travel through the road segment. The navigation system selects the potential route with the lowest total cost to be the recommended route. Depending upon the predetermined algorithm of the navigation system, the navigation system will recommend the route with the shortest total length, the lowest total time, or some weighted average of length and time.

The recommended route is then displayed to the user as a map showing the starting point and desired destination and highlighting the recommended route. Preferably, if the navigation system is installed in a vehicle, the navigation system displays the current position of the vehicle and turn-by-turn instructions to the driver, guiding the driver to the selected destination.

Some drivers prefer to avoid certain roads that they believe to be congested or certain areas that they believe to be unsafe. Some drivers may have a preference or aversion for particular types of roads such as highways or toll roads. Further, a route which is the shortest distance is sometimes preferred, while a route which is the lowest total time of travel is preferred at other times.

Current navigation systems have several limitations in how they select a potential route as the recommended route. The known navigation systems permit the driver to select one of the following preferences: fastest route; shortest route; use highways; avoid highways. However, the known systems do not permit the driver to adjust a weighting factor to be given to these preferences; nor can the driver adjust a balance between the fastest and shortest routes. Further, the known navigation systems do not permit the user to designate selected areas or roads to avoid or to adjust a preference/aversion factor of the road or area.

### SUMMARY OF THE INVENTION

The present invention provides a navigation system which permits the user to modify the cost of roads when planning a route. The navigation system generally includes a database of roads to be traveled by a user. Each road in the database

includes a "cost" for each road segment, such as estimated time of travel across that road segment and estimated length of travel across that road segment. A beginning point relative to the database of roads is input from a position determining device, such as a GPS system, or is input by the user, utilizing a mouse, keyboard or joystick. The user then selects a desired destination relative to the database of roads. The user selectively adjusts the cost for selected road segments or groups of road segments. When the navigation system determines a route from the selected beginning point to the desired destination, the navigation system evaluates the cost of the road segments to be traveled in several potential routes and recommends the potential route having the lowest total cost.

Because the user can selectively modify the cost of selected road segments, the user can indicate a preference or avoidance of such roads which will be considered by the navigation system when planning a route. For example, if the cost of a road segment is increased, the navigation system is less likely to recommend a potential route which includes that road segment. Similarly, if the cost of a selected road segment is decreased, the navigation system is more likely to recommend a potential route which includes that road segment.

Adjusting the cost of selected road segments can have many potential applications. First, by increasing the cost of certain road segments selected by the user, the user can indicate the road segments that the user desires to avoid, because the user believes these road segments to be congested or in an unsafe area. Alternatively, the navigation system can include a data receiving device which receives information regarding congested road segments and automatically updates congestion level values associated with each road segment.

By categorizing each road segment into a road type, such as highway, toll road, etc., the user can modify the cost of selected types of roads, thereby indicating a preference for highways or toll roads or an aversion to highways or toll roads. Further, by modifying the estimated time of travel of road segments differently than the estimated length of travel of road segments, the user can adjust the preference for a route having a low estimated time of travel or a low estimated distance of travel.

### BRIEF DESCRIPTION OF THE DRAWINGS

The above, as well as other advantages of the present invention, will become readily apparent to those skilled in the art from the following detailed description of a preferred embodiment when considered in the light of the accompanying drawings in which:

FIG. 1 is a schematic of the navigation system of the present invention installed in a vehicle having a position determining device;

FIG. 2 is a flow chart of the navigation system of FIG. 1;

FIG. 3 is a screen of the display of the navigation system of FIG. 1 illustrating a route guidance instruction;

FIG. 4 is a flow chart of the Route Planning routine in FIG. 2.

### DETAILED DESCRIPTION OF A PREFERRED EMBODIMENT

The navigation system **20** of the present invention is shown schematically in FIG. 1. The navigation system **20** includes a CPU **22** connected to a display **24**, such as a high resolution LCD or flat panel display. The CPU **22** is also

connected to an input device 26, such as a mouse or keyboard. Alternatively, the display 24 can be a touch screen display. The navigation system 20 further includes a database 28 connected to the CPU 22. The database 28 is a mass media storage device, such as a CD ROM which includes a map of all of the roads in the area to be traveled by the user. Each road in the database is divided into road segments, each having an associated set of cost values, which indicate the "cost" of traveling that road segment. For example, the cost values include the length of the road segment, the estimated time to travel the road segment, the type of road (i.e. highway, secondary road, toll road, one way, etc.), and congestion level.

The navigation system 20 can, but need not, be installed in a vehicle 32. The navigation system 20 can be used in conjunction with position-determining devices, such as a GPS system 34, a gyroscope 36, a compass 38, and a wheel speed sensor 40, all connected to the CPU 22 [connections not shown for simplicity]. Such position determining devices are well known and are commercially available. Preferably, a combination of these position determining devices is utilized. The navigation system 20 further includes a data receiver 42, such as a radio receiver for receiving up-to-date broadcast information regarding the congestion levels of area road segments. Congestion-monitoring devices are known and currently used to automatically monitor the congestion levels of certain road segments, typically near intersections. Preferably, information regarding congestion from the congestion-monitoring devices is broadcast to the surrounding area and received by the data receiver 42. The data receiver 42 sends the congestion information to the CPU 22, which stores the updated congestion information. Alternatively, many radio stations broadcast information regarding the congestion levels of area road segments. This congestion information can be added manually by the user to the CPU 22.

The operation of the navigation system 20 is shown in FIG. 2. For purposes of illustration, the navigation system 20 of the present invention will be described as installed in a vehicle 32 having position determining devices. At power-up, the navigation system 20 preferably begins in the main menu 50, which informs the user that he may elect to plan a route 52, edit congested roads 54, or edit routing criteria 56.

By selecting to edit congested roads in step 54, the user can delete items from the congested road list in step 96, add items to the congested road list in step 98, or edit the congestion levels in step 99. If the user elects to add items in step 98, the display 24 prompts the user to select a road segment from a local area, a road segment in another area, or all road segments in an area. Utilizing the mouse 26, if the user wishes to add all road segments in an area to the congested road list, the user selects a state in step 100 and a city or area in step 102. The user then sets the congestion level in step 103. Preferably, the congestion level is selected from at least 3 levels and most preferably 14 levels. Preferably, the lowest congestion level assigns a congestion value of 1.0, signifying no known congestion. Level 14, the highest level, would assign a congestion level on the order of 10,000, indicating an almost absolute avoidance, unless there is no alternate route, such as if the destination or beginning point is located on that road segment. Preferably, the congestion value for each level increases approximately by a factor of 1.7, such that the congestion value is assigned by level 2 is 1.7, level 3 is 2.89, level 4 is 4.9 and level 5 is 8.35, etc.

If the user elects to add a road segment in the immediate area surrounding the present vehicle location, the user

selects a road in step 108 by entering the first few letters of the road name and then selecting the road from an alphabetized list. If the user elects to add a road in another area, the user must first select a state in step 110 and a city or area in step 112.

After selecting a road in step 108, the user selects a particular road segment or segments in step 114 such that the congested area includes a road segment between selected exits, a single exit, a single intersection, the entire road within a city, the entire road within an area, etc. If the user has not selected a road segment which is a one way street, the user can select to edit the congestion level in a single direction or in both directions in step 116. The congestion level is then set in step 103.

If the user elects to delete items from the congested road list in step 96, a list of all roads, cities, areas, or road segments for which a congestion level has been set, is displayed. Utilizing the mouse 26, the user selects an item or items to be deleted from the congested road list. The user can utilize this adjustment to select or not select roads, geographic areas, etc. that the user wishes to avoid or use for purely personal reasons. The display at step 96 may include the legend "Edit Personal Preference", or a separate election can be added to the system for personal preference. The user would increase the congestion value for an area or road that he wishes to avoid. Also, the system could include a display or "Personal Preference" that can be adjusted and then used similarly to the congestion value.

The user can also elect to edit the congestion levels in step 99, in which case the entire list of roads, road segments, cities, and areas is displayed. The user selects an item from the list utilizing the mouse 26, and sets the congestion level for that item in step 103.

If the user elects to edit the routing criteria 56 from the main menu 50, the user can modify the time/distance factor in step 128 utilizing the mouse 26. Preferably, the user selects one of at least 7 levels for the time/distance factor. The time/distance factor is a value to be multiplied by an estimated time of travel to weight it for comparison against an estimated length of travel. The lowest level, level 1, would preferably have a time/distance factor of zero miles per hour, indicating an absolute preference for the route having the lowest estimated time of travel, rather than shortest length of travel. The highest level, level 7, would preferably have a time/distance factor of 1000 miles per hour, indicating an almost absolute preference for the lowest length of travel route, rather than the lowest estimated time of travel route. The middle level, level 4, would preferably have a time/distance factor of 45 miles per hour, indicating a medium preference between the route having the lowest estimated time of travel and the road having the lowest estimated length of travel. The other levels would have intermediate time/distance factors.

From the routing criteria menu 56, the user can elect to modify the highway preference/avoidance factor in step 132. The highway preference/avoidance factor multiplies the cost of any highways in potential routes. Preferably, the display 24 displays at least 7 levels to the user, which can be selected using the mouse 26. The middle level, level 4, would have a highway preference/avoidance factor of 1.0, indicating no preference or avoidance of highways. Level 1, avoidance, would preferably have a highway preference/avoidance factor of 1000, indicating an almost absolute total avoidance of highways. Level 7, preference, would preferably have a highway preference/avoidance factor of 0.2, indicating a preference for highways, by effectively decreasing the cost

of highways by a factor of 5. Preferably, the navigation system **20** further includes the data receiver **42** which receives information regarding congested road segments in the surrounding area and sends the congestion information to the CPU **22**, where the congestion levels of the appropriate road segments are updated. Alternatively, or in addition, the data receiver **42** can be a standard radio which receives local broadcasts regarding the congestion levels of area road segments, in which case the user could manually update the congestion levels for the appropriate road segments.

From the routing criteria menu **56**, the user can also elect to modify the toll roads preference/avoidance factor in step **136**. Preferably, the display **24** displays to the user at least 7 levels for the toll road preference/avoidance factor, which can be selected utilizing the mouse **26**. The middle level, level **4**, would have a toll road preference/avoidance factor of 1.0, indicating no preference or avoidance of toll roads. Level **1**, avoidance, would preferably have a toll road/avoidance factor of 10, indicating an avoidance of toll roads so long as the cost is otherwise increased by less than a factor of 10. Level **7**, preference, would preferably have a toll road preference/avoidance factor of 0.2, indicating a preference for toll roads so long as the cost is not otherwise increased by a factor of 5. The remaining levels would have appropriately scaled intermediate factors.

If the user elects to plan a route **52**, the navigation system **20** inputs a starting point relative to the database **28** in step **157**. If the navigation system **20** includes a position determining devices, the current position of the vehicle **32** is input as the starting point for the route to be planned. Otherwise the user selects a starting point utilizing the display **24** and mouse **26**. Preferably the user types in the first few letters of the name of the road and then selects the starting point road from a list of roads. The user then selects an intersection or address as a beginning point.

The navigation system **20** then inputs the destination. In step **158**, the user selects a destination from the local area surrounding the current vehicle position or from all areas. If the user wishes to select a destination from a local area, the user selects a road as the destination to which the route will be guided in step **160**. Otherwise the user must first select a state in step **162** and a city or area in step **164**. In step **166**, the navigation system **20** requests whether to plan the route to a specific intersection of the selected road in step **168**, a specific address on the selected road in step **170** or the nearest point on the selected road in step **172**.

In step **176**, the navigation system **20** plans a route from the starting point to the selected destination utilizing the roads in the database **28**. The navigation system **20** evaluates the total cost of a plurality of potential routes between the starting point and selected destination. The navigation system **20** selects the potential route from the starting point to the selected destination which has the lowest total cost as modified by the user in the Route Planning routine **176**, described more fully below.

If the vehicle **32** is moving when the route planning routine **176** is completed, the display **24** of the navigation system **20** displays route guidance information in step **178**. Preferably, the navigation system **20** displays "turn-by-turn" information to the driver, i.e., the display **24** displays a map of the immediate area showing the present position of the vehicle and the next maneuver in the recommended route. If the vehicle **32** is stationary at the time the route planning routine **176** is complete, the display **24** preferably displays a list of the road segments in the recommended route in step

**180**. As the user scrolls up and down through the road segments in the recommended route list, a graphical image of the recommended maneuver (i.e., turn right or turn left) is displayed adjacent the route list. In step **182**, the user can edit the route list by selecting one of the segments in the recommended route list. In step **186**, the user adds the selected road segment from the recommended route list to the congested roads list. In step **190**, the user sets the congestion level for the selected road segment. Preferably, if the item was not previously on a congested road list, the congestion value is set to 1.7. If the road segment was already on the congested road list, the congestion value is multiplied by 1.7 in step **190**. If the user edits the route list, the navigation system **20** must replan the route in step **176**, utilizing the new cost values. If the vehicle **32** is moving, the navigation system **20** will then proceed to step **178**, where the display **24** will display turn-by-turn route guidance instructions to the driver. As shown in FIG. **3** the display **24** preferably displays a map of the immediate area showing the present position of the vehicle and the next maneuver in the recommended route.

The Route Planning routine **176** is shown in detail in FIG. **4**. First, the CPU **22** determines potential routes from the beginning point to the desired destination in the road database **28** in step **194**. In step **196**, the CPU **22** multiplies the cost of each road segment by the congestion level for that road segment if the congestion level has been set. For example, if one of the road segments in one of the potential routes from the starting point to the selected destination includes a congestion value of 1.7, the length and estimated time of travel for that road segment are multiplied by 1.7.

In step **198**, the CPU **22** multiplies the cost of each road segment which is a highway by the highway preference/avoidance factor. If the user has defined a preference/avoidance value for highways, the cost (time and length) of the highway road segments in the potential routes are multiplied by the highway preference/avoidance value. If highways are preferred, the highway preference/avoidance value is less than 1, thereby reducing the length and estimated time of travel for purposes of estimating the "cost" of travelling highways. If the highway preference/avoidance value is greater than 1, the length and estimated time of travel of highway road segments will be increased, thereby increasing the "cost" of highway road segments.

In step **200**, the CPU **22** multiplies the cost of any potential road segments which are toll roads by the toll road preference/avoidance factor. Again, a value less than one would reduce the effective cost of travelling toll roads, thereby indicating a preference for toll roads. A value greater than one would increase the effective cost of toll roads, thereby indicating an aversion to toll roads.

In step **202**, the CPU **22** selects the potential route which has the lowest total time cost, after factoring in the aforementioned user preferences. Similarly, in step **204**, the CPU **22** selects the potential route which has the lowest distance cost, after factoring in the afore-mentioned user preferences.

In step **206**, the CPU **22** compares the lowest time cost potential route with the lowest distance cost potential route. The time cost of the lowest time cost route is multiplied by the time/distance factor to convert it to a distance to be compared to the distance cost in the lowest distance cost potential route.

In step **208**, the CPU **22** selects the route with the lower distance cost, after converting the time of the lowest time cost route to distance utilizing the time/distance factor. For example, at level **1**, the time/distance factor would be set to



zero, in which case the lowest time cost potential route would always be selected over the lowest distance cost route. At level 4, each hour in the lowest time cost route would be converted to 45 miles, indicating a medium balance between the shortest route and the quickest route. At level 7, each hour in the lowest time cost route would be converted to 1000 miles, which would effectively ensure that the lowest distance route would have a lower cost than the lowest time cost route, indicating a strong preference for the shortest route rather than the quickest route.

Preferably, the settings selected by the user are stored and are utilized when the user plans the next route to a new destination. Optionally, the navigation system 20 can reset the congestion levels, highway preference/avoidance, toll road preference/avoidance and time v cost factor when the navigation system 20 is turned off, or when the destination is reached.

In accordance with the provisions of the patent statutes, the present invention has been described in what is considered to represent its preferred embodiment. However, it should be noted that the invention can be practiced otherwise than as specifically illustrated and described without departing from its spirit or scope.

What is claimed is:

1. A navigation system comprising:

a database of road segments to be travelled by a user, said database including a cost associated with each said road segment;

a system for selecting a beginning point relative to said database of roads;

a user input device for selecting a desired destination relative to said database of roads, said user input device manually selecting at least one of said road segments and adjusting said cost of said at least one selected road segment; and

a system for determining a route from said database of roads between said beginning point and said desired destination based upon said adjusted cost of said selected at least one road segment.

2. The navigation system of claim 1 wherein said user input device enters the first few letters of said selected road segment, said user input device selecting said selected road segment from a list of road segments including said first few letters.

3. The navigation system of claim 1 wherein said user input device selects a city and adjusts the cost for a plurality of road segments in said selected city.

4. The navigation system of claim 1 wherein said user input device selects from at least three values in order to adjust said cost of said at least one selected road segment.

5. The navigation system of claim 1 wherein said system for adjusting said cost includes a system for receiving congestion information, said congestion information including identification of a congested area.

6. The navigation system of claim 1 wherein said user input device selects a road segment to avoid, said system for adjusting said cost increasing the cost for said selected road segment to avoid.

7. The navigation system of claim 1 wherein said system for determining a route recommends a plurality of recommended road segments in said route, said user input device selecting at least one, but not all, of said plurality of recommended road segments, said user input device selectively editing the cost of said selected at least one of said recommended road segments, said system for determining a route determining a second route including said plurality of

recommended road segments other than said selected at least one road segment.

8. The navigation system of claim 1 further including a memory storing each selected road segment for which the cost has been adjusted and the associated adjusted cost of said selected road segment, wherein said beginning point is a first beginning point, said destination is a first destination and said route is a first route, said system for determining a route determining a second route from said database of roads between a second beginning point different from said first beginning point and a second desired destination based upon said adjusted cost of each said selected road segment as stored in said memory.

9. The navigation system of claim 8 wherein each said selected road segment and its associated adjusted cost is further associated with a user.

10. The navigation system of claim 1 wherein said road segments each have an associated road type, said user input device selecting a road type and adjusting the cost for all road segments of said selected type.

11. The navigation system of claim 10 wherein said road type includes freeways.

12. The navigation system of claim 1 wherein said user input device selects between decreasing and increasing the cost of said selected road segment.

13. A navigation system comprising:

a database of road segments to be travelled by a user, said database including a cost associated with each said road segment, said road segments each having a time cost and a distance cost;

a system for selecting a beginning point relative to said database of roads;

a user input device for selecting a desired destination relative to said database of roads;

a system for adjusting said cost of at least one selected road segment of said plurality of road segments utilizing said user-input device; and

a system for determining a route from said database of roads between said beginning point and said desired destination based upon said adjusted cost of said selected road segment, said system for determining a route comparing the time cost of a first road segment with a distance cost of a second road segment and recommending a route based upon a time/distance weighting factor, said user input device adjusting said time/distance weighting factor.

14. The navigation system of claim 13 wherein said road segments each have an associated road type, said system for adjusting said cost adjusting the cost for all road segments of a selected type.

15. A method for planning a route including the steps of:

a) selecting a beginning point relative to a database of roads;

b) selecting a destination relative to said database of roads;

c) manually selecting a road segment from said database of roads;

d) adjusting a cost associated with said selected road segment; and

e) determining a route from said database of roads from said beginning point to said destination based upon said adjusted cost of said selected road segment.

16. The method for planning a route according to claim 15 wherein said step c) further includes the steps of:

entering the first few letters of the name of said selected road segment;

selecting said road segment from a list of road segments having said first few letters.

**17.** The method for planning a route according to claim **15** further including the steps of:

associating an estimated time of travel with said road segment;

associating a length of travel with said road segment; and

adjusting the cost of a road segment proportionally to its estimated time of travel or estimated length of travel.

**18.** The method for planning a route according to claim **15** further including the steps of:

selecting a time/distance factor for evaluating the cost of potential routes between said beginning point and said desired destination;

selectively adjusting said time/distance factor; and

determining a route from said database of roads from said beginning point to said desired destination based upon said time/distance factor, said estimated time of travel and said length of travel.

**19.** The method for planning a route according to claim **15** further including the steps of:

determining a present position relative to said database of roads; and

selecting said present position relative to said database of roads as said beginning point.

**20.** The method for planning a route according to claim **15** further including the steps of:

displaying a list of road segments for which the cost has been adjusted;

selecting said selected road segment from said list of road segments; and

adjusting the cost of said selected road segment.

**21.** The method for planning a route according to claim **15** wherein said step d) includes the step of decreasing the cost of said selected road segment.

**22.** The method for planning a route according to claim **15** wherein said step d) includes the step of selecting between increasing or decreasing the cost of said selected road segment.

**23.** A method for planning a route including the steps of:

- a) selecting a beginning point relative to a database of roads;
- b) selecting a destination relative to said database of roads;
- c) adjusting a cost associated with a selected road segment in said database of roads; and
- d) selecting a time/distance factor for evaluating the cost of potential routes between said beginning point and said desired destination;
- e) comparing the estimated time of travel of a first potential route with the length of travel of a second potential route utilizing said time/distance factor;

- f) determining a route from said database of roads from said beginning point to said desired destination based upon said time/distance factor, said estimated time of travel and said length of travel.

**24.** A method for planning a route including the steps of:

- a) selecting a beginning point relative to a database of roads;
- b) selecting a destination relative to said database of roads;
- c) selecting a road segment to avoid;
- d) increasing the cost of said road segment;
- e) comparing said increased cost for said road segment to avoid with a cost of an alternative route not including said road segment; and
- f) determining a route from said database of roads from said beginning point to said destination based upon said increased cost.

**25.** The method for planning a route according to claim **24** further including the steps of:

displaying a first route comprising a plurality of road segments from said beginning point to said destination;

selecting one of said plurality of road segments as a road segment to avoid; and

determining a second route to said destination from said position of said vehicle, said second route not including said road segment to avoid.

**26.** A method for planning a route including the steps of:

- a) selecting a beginning point relative to a database of roads, said database of roads having a plurality of road segments;
- b) selecting a destination relative to said database of roads;
- c) associating a time cost with each said road segment;
- d) associating a distance cost with each said road segment;
- e) selecting a first time/distance factor;
- f) selecting a first recommended route from said beginning point to said destination based upon said time cost of said road segments, said distance cost of said road segments and said first time/distance factor;
- g) changing said first time/distance factor after said step f) to a second time/distance factor; and
- h) selecting a second recommended route from said beginning point to said destination based upon said time cost of said road segments, said distance cost of said road segments and said second time/distance factor, said second recommended route including at least one road segment not included in said first recommended route.

\* \* \* \* \*