

EXHIBIT F



- [54] **KEY MANAGEMENT FOR NETWORK COMMUNICATION**
- [75] Inventors: **Roger H. Levesque**, Tewksbury;
Jeffrey A. Kraemer, Northboro; **Ashok P. Nadkarni**, Shrewbury, all of Mass.
- [73] Assignee: **Raptor Systems, Inc.**, Waltham, Mass.
- [21] Appl. No.: **959,919**
- [22] Filed: **Oct. 29, 1997**

Related U.S. Application Data

- [63] Continuation of Ser. No. 586,231, Jan. 16, 1996, abandoned.
- [51] **Int. Cl.**⁶ **H04L 9/00**
- [52] **U.S. Cl.** **380/49**
- [58] **Field of Search** 380/23, 49; 370/406, 370/466

References Cited

U.S. PATENT DOCUMENTS

5,099,517	3/1992	Gupta et al.	380/49
5,161,193	11/1992	Lampson et al.	380/49
5,235,644	8/1993	Gupta et al.	380/49
5,325,362	6/1994	Aziz	370/96.3
5,416,842	5/1995	Aziz	380/49
5,442,708	8/1995	Adams, Jr. et al.	380/49
5,444,782	8/1995	Adams, Jr. et al.	380/49
5,548,646	8/1996	Aziz et al.	380/23
5,550,984	8/1996	Gelb	370/94.1

OTHER PUBLICATIONS

- "Internet Portal, Version 1.1", pp. 1-16, Digital Equipment Corp., May 18, 1990.
- "Digital Internet Tunnel V 1.0" pp. 1-3 Digital Equipment Corp., Nov. 15, 1995.
- "Internet Security: Screening External Access Link Seal", Digital Equipment Corp pp. 1-2, May 1, 1994.
- World Wide Web document of Digital Equipment Corporation's tunneling product, Jan. 1996.
- Kerberos Network Authentication Service (V5), Digital Equipment Corporation, pp. 1-106, Sep. 1993.

swIPe IP Security Protocol, Columbia University and AT&T, John Ioannidis and Matt Blaze, Dec. 1993.

Security Architecture for the Internet Protocol, R. Atkinson, Naval Research Laboratory, pp. 1-44, Aug. 1995.

IP Authentication Header, R. Atkinson, Naval Research Laboratory, pp. 1-26, Aug. 1995.

IP Encapsulating Security Payload (ESP), R. Atkinson, Naval Research Laboratory, pp. 1-24, Aug. 1995.

The Photuris Session Key Management Protocol, P. Karn, Qualcomm, W.A. Simpson, DayDreamer, pp. 1-106, Nov. 1995.

Simple Key-Management For Internet Protocols (SKIP), Ashar Aziz, et al. Sun Microsystems, Inc., pp. 1-72, Dec. 1995.

Internet Security Association and Key Management Protocol (ISAKMP), Douglas Maughan and Mark Schertler, National Security Agency, pp. 1-117, Nov. 1995.

U.S. Patent Application Serial No. 08/561,790, filed Nov. 22, 1995, Kirby et al.—Controlling Passage Of Packets Or Messages.

U.S. Patent Application Serial No. 08/585,765, filed Jan. 12, 1996, Kirby et al.—Data Encryption/Decryption For Network Communication.

U.S. Patent Application Serial No. 08/586,230, filed Jan. 12, 1996, Kirby et al.—Transferring Encrypted Packets Over A Public Network.

Primary Examiner—Salvatore Cangialosi
Attorney, Agent, or Firm—Fish & Richardson P.C.

[57] **ABSTRACT**

The invention features a method for enabling computers to communicate using encrypted network packets. A configuration request is sent over a network from a first computer to a second computer, and tunnel record information is sent over the network from the second computer to the first computer. The tunnel record information is encrypted in accordance with a temporary configuration password.

The invention also features a method for updating a tunnel record. A connection request is sent from a first computer to a second computer, and the first computer is authorized. A tunnel record corresponding to the connection request with the first computer's network address is then updated.

9 Claims, 10 Drawing Sheets

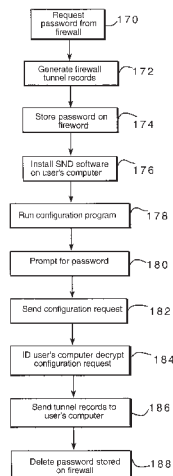

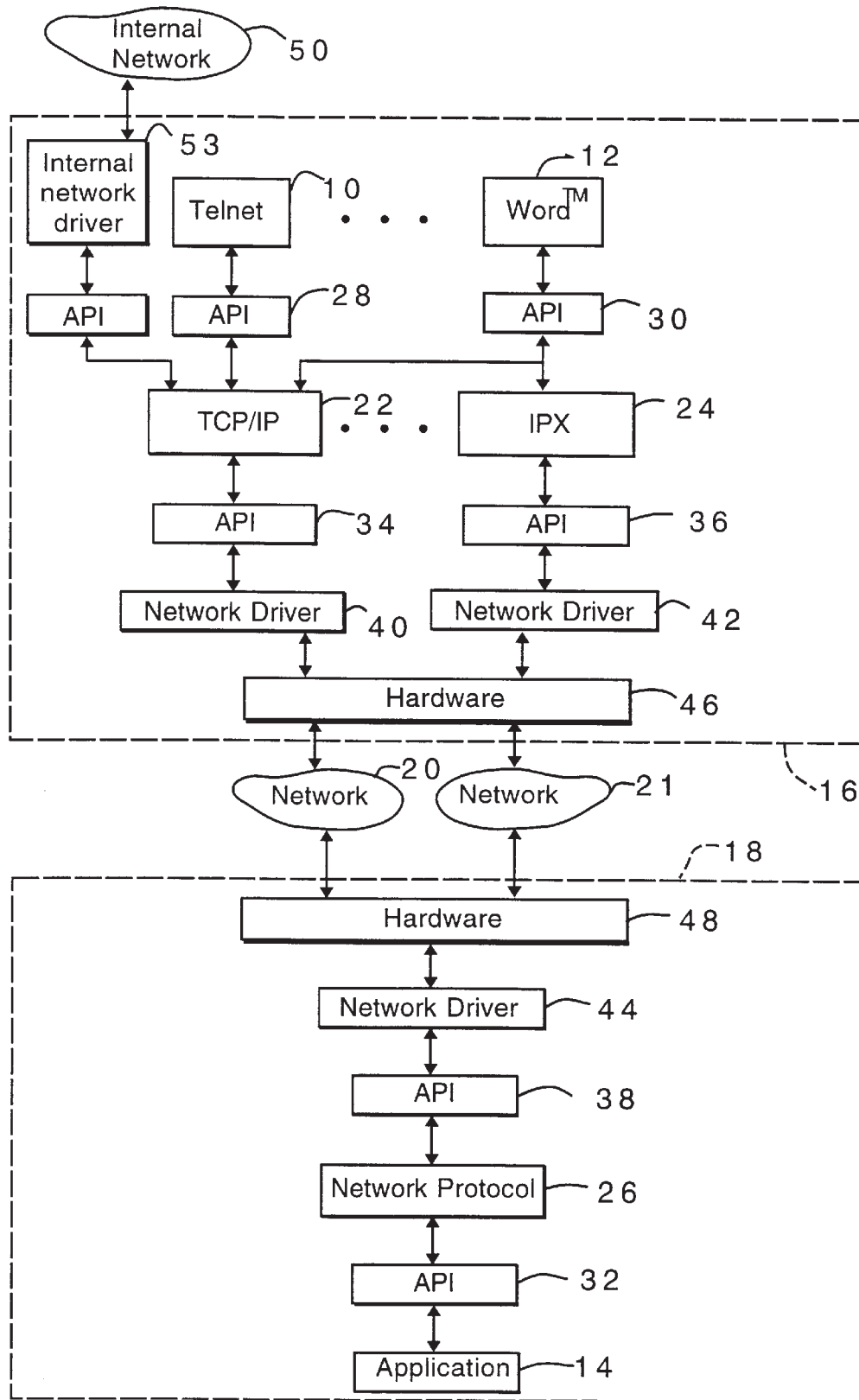

FIG. 1

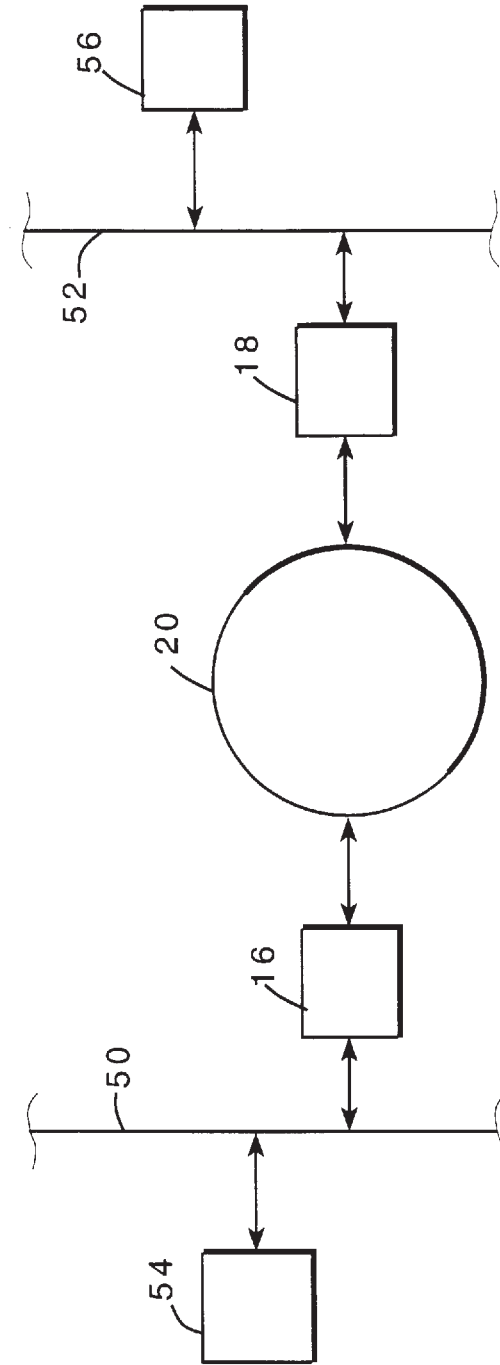

FIG. 2

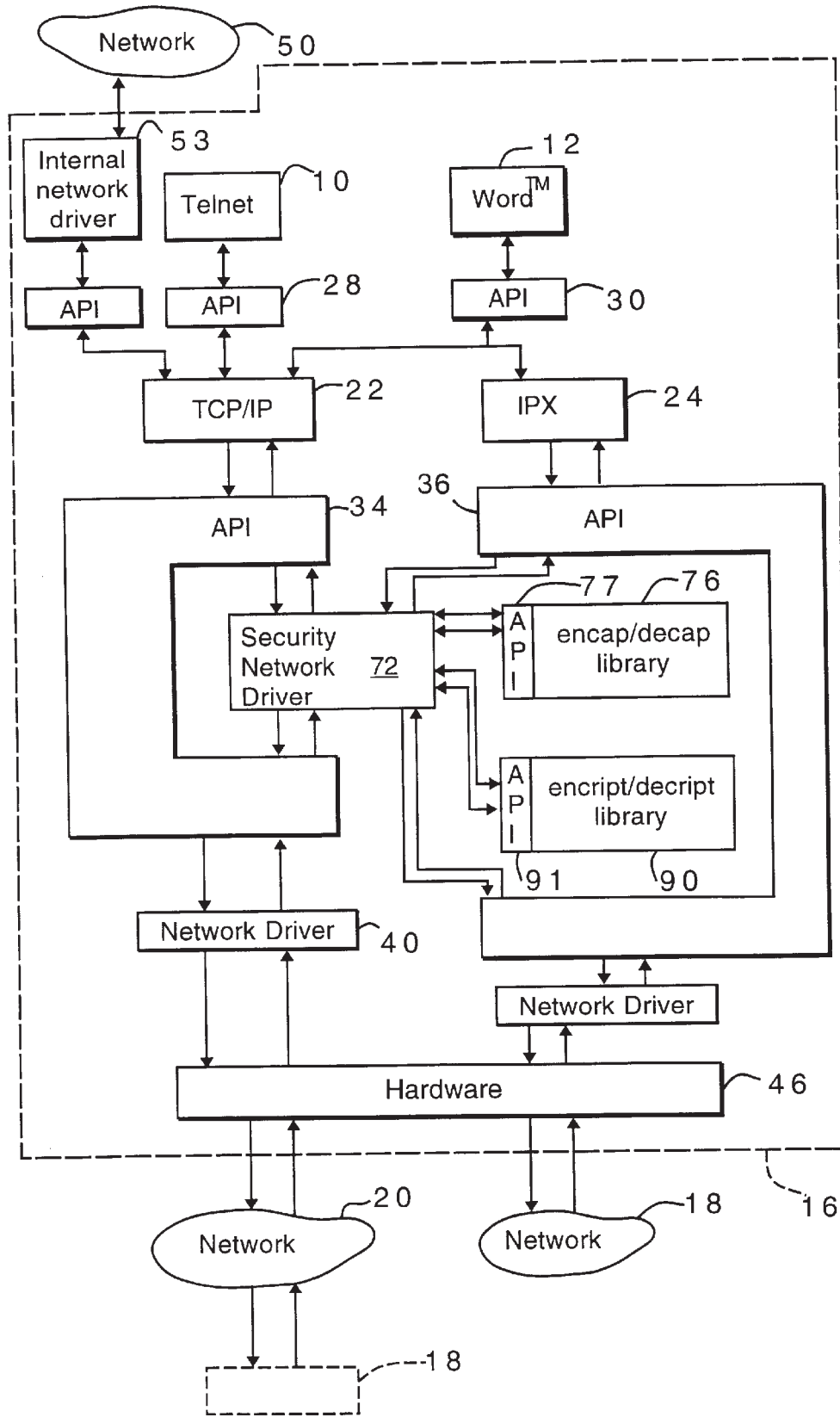

FIG. 3

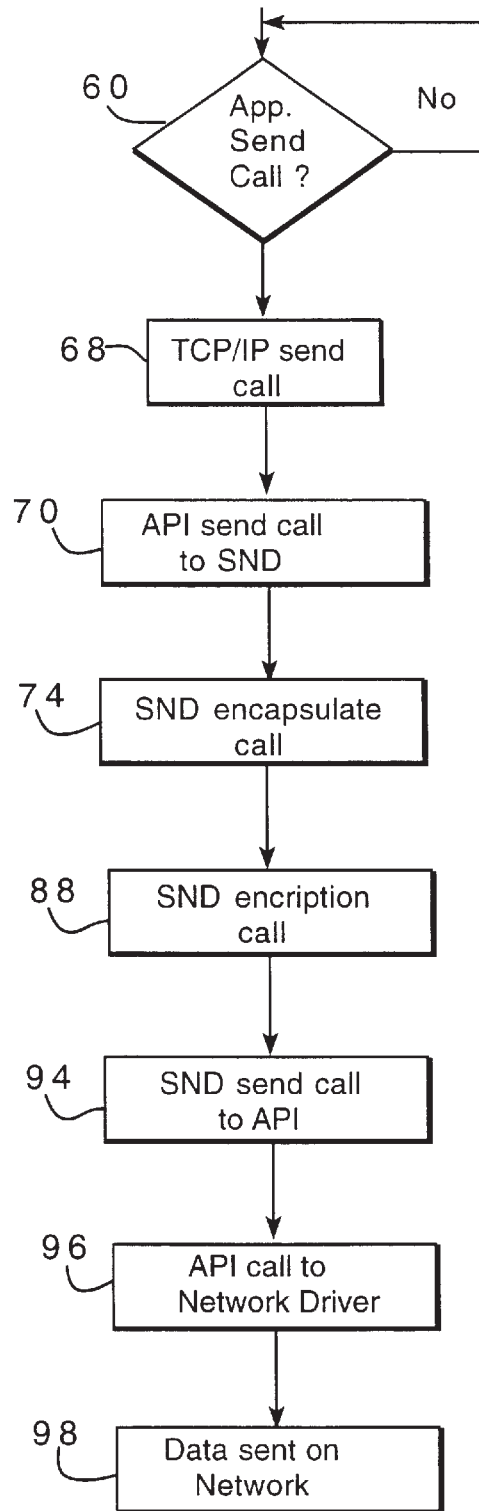

FIG. 4

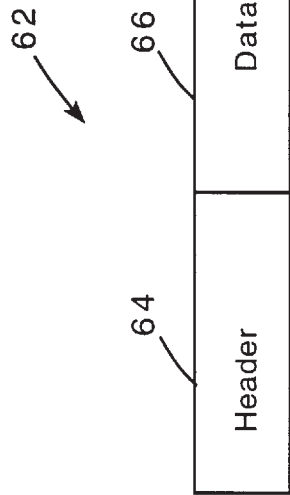

FIG. 5

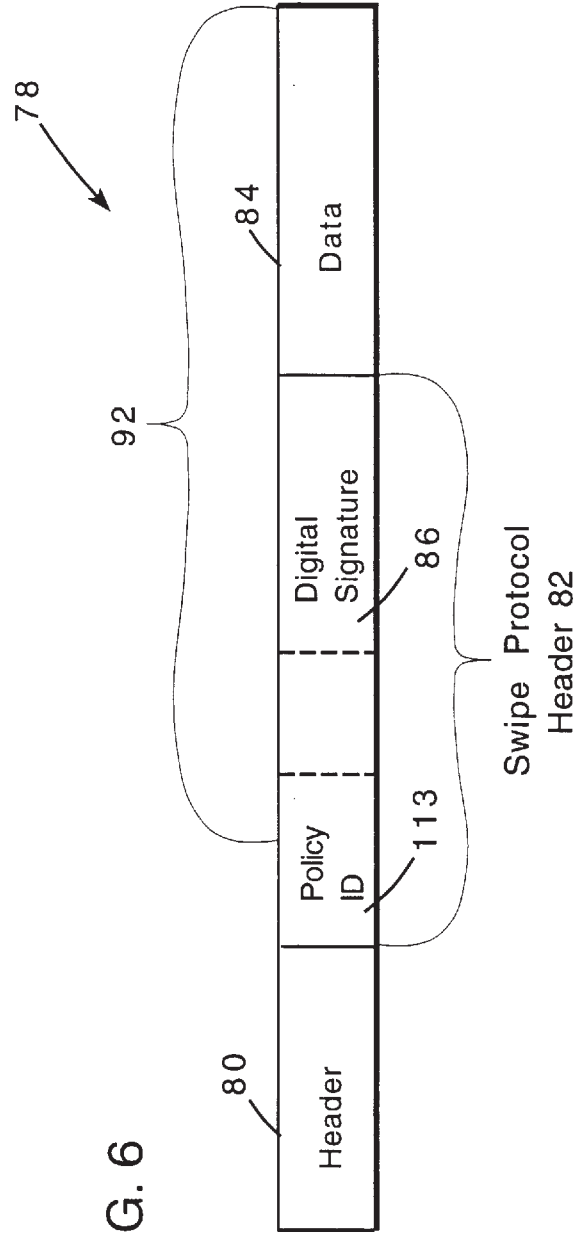

FIG. 6

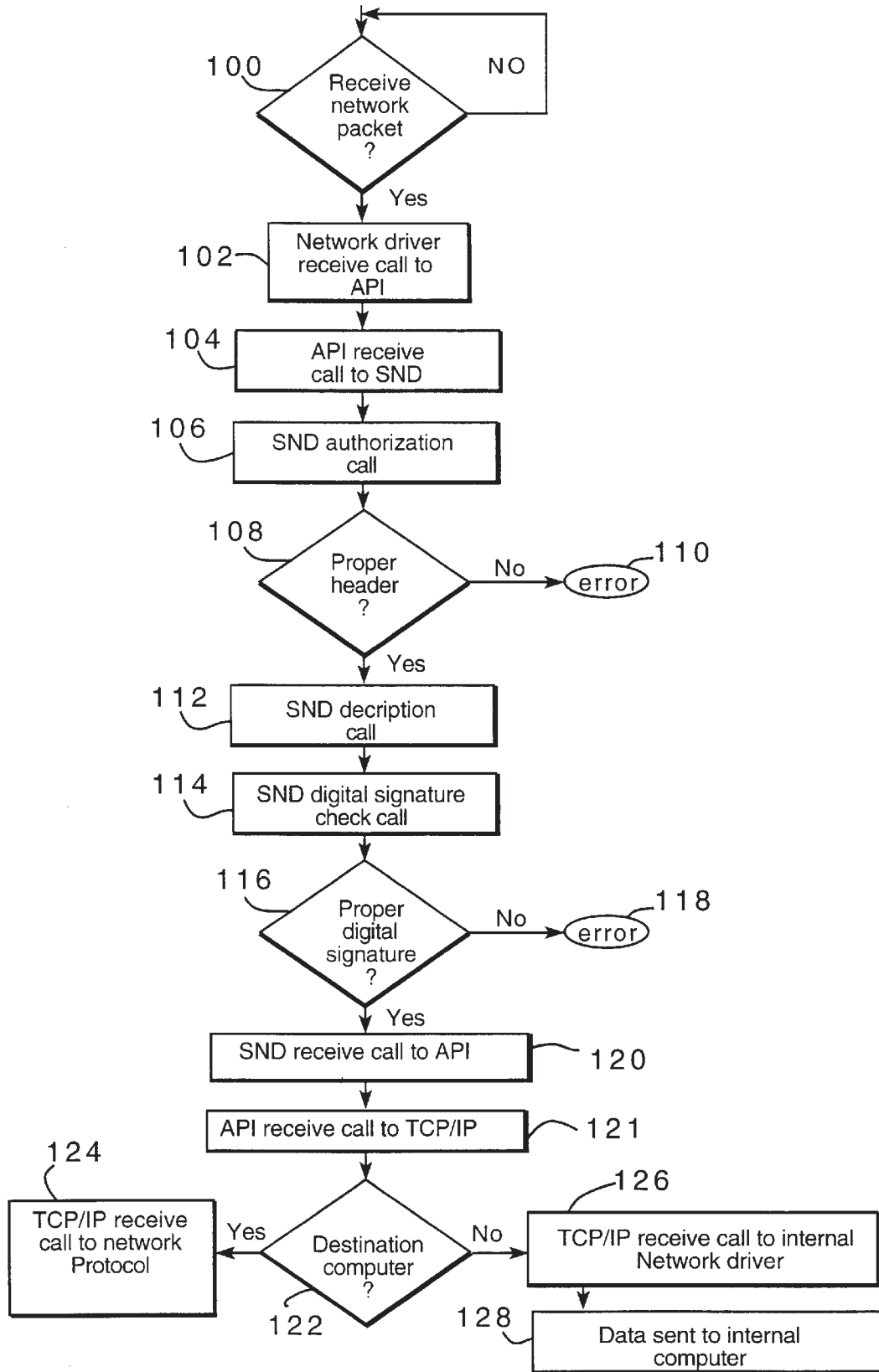

FIG. 7

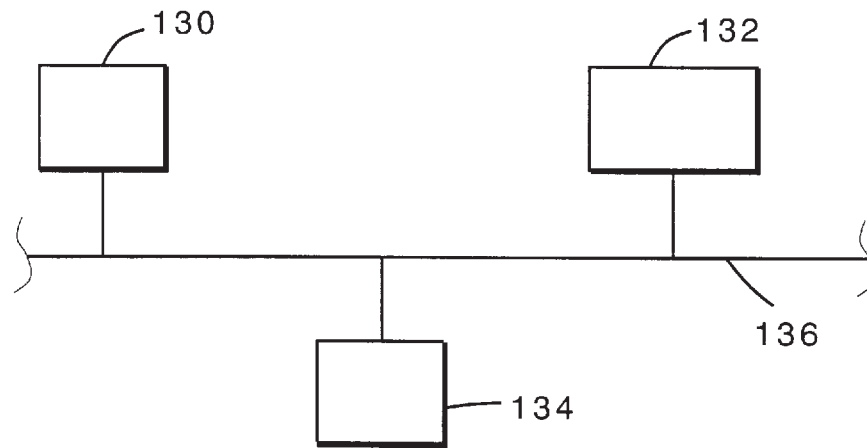

FIG. 9

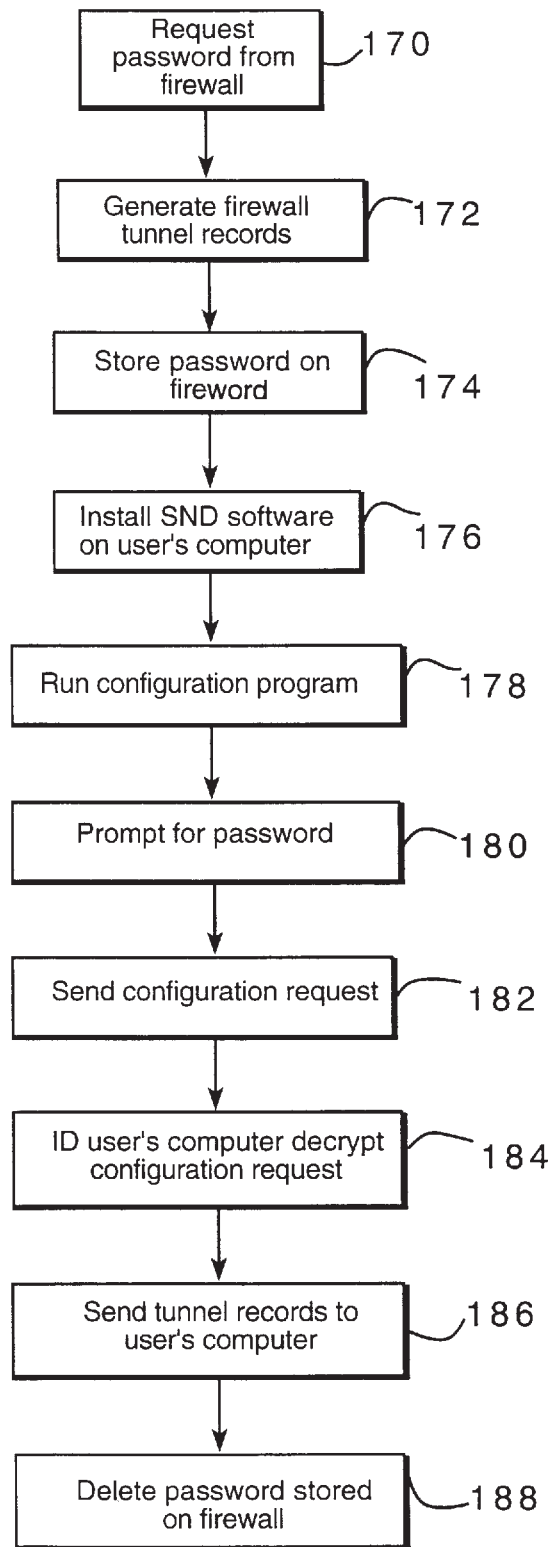

FIG.10

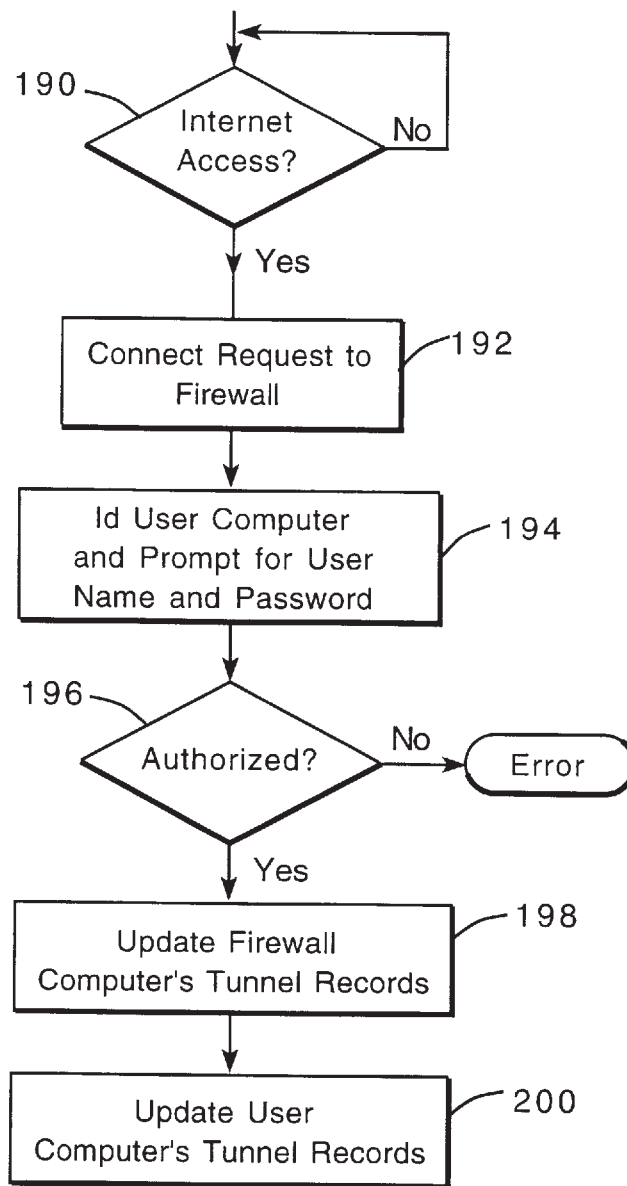

FIG. 11

KEY MANAGEMENT FOR NETWORK COMMUNICATION

This is a continuation of application Ser. No. 08/586,231, filed Jan. 16, 1996, now abandoned.

BACKGROUND

This invention relates to key management for network communication.

Referring to FIG. 1, while executing a variety of software applications, 10, 12, 14, for example, Telnet 10 or Microsoft™, Inc. Word™, computers 16 and 18 may exchange data over networks 20, 21, for example, a telephone company network, a private network, or a public network such as the internet or X.25. The applications communicate using network protocols 22, 24, 26, for example, transmission control protocol/internet protocol (TCP/IP) 22 or internet packet exchange (IPX) 24, through application programming interfaces 28, 30, 32. Through application programming interfaces 34, 36, 38, the network protocols communicate with network drivers 40, 42, 44 to direct network interface hardware 46, 48 to transfer data over the networks.

While on a network, data being transmitted, including the addresses of the source and destination computers 16, 18, is accessible to others who may be monitoring the network. For security, the data is often encrypted before being sent on the network.

Referring also to FIG. 2, for additional security, firewall computers 16, 18, which have direct access to a network 20 may be used to prevent unauthorized access to internal/private networks 50, 52. For example, when an internal network driver 53 within firewall computer 16 receives data from an internal computer 54 that is destined for a computer 56 on a public network, it encrypts the data and the addresses of source computer 54 and destination computer 56. Computer 16 then prepends to the encrypted data a new IP header including its own address as well as the address of a destination computer, which may also be a firewall computer, e.g., computer 18.

When a firewall computer receives a network packet from the network, it determines whether the transmission is authorized. If so, the computer examines the header within the packet to determine what encryption algorithm was used to encrypt the packet. Using this algorithm and a secret key, the computer decrypts the data and addresses of the source and destination computers 54, 56 and sends the data to the destination computer. If both the source and destination computers are firewall computers, the only addresses visible (i.e., unencrypted) on the network are those of the firewall computers. The addresses of computers on the internal networks, and, hence, the internal network topology, are hidden. This has been termed "virtual private networking" (VPN).

Encrypting/decrypting data has been performed by complex security software within applications or, to simplify the applications, encrypting/decrypting has been performed within the protocol stack of network protocols.

SUMMARY

In general, in one aspect, the invention features a method for enabling computers to communicate using encrypted network packets. A configuration request is sent over a network from a first computer to a second computer, and tunnel record information is sent over the network from the

second computer to the first computer. The tunnel record information is encrypted in accordance with a temporary configuration password.

Implementations of the invention may include one or more of the following features. Before sending a configuration request over a network, the method may include generating, on the second computer, the tunnel record information. A network packet may be sent over the network through a virtual tunnel between the first and second computers, where the network packet is encrypted in accordance with a secret key in the tunnel record information corresponding to the virtual tunnel. The second computer may be a firewall computer, and the network may be a public network.

In general, in another aspect, the invention features a method for updating a tunnel record. A connection request is sent from a first computer to a second computer, and the first computer is authorized. A tunnel record corresponding to the connection request with the first computer's network address is then updated.

Implementations of the invention may include one or more of the following features. Authorizing may include identifying the first computer. Authorizing may also include prompting the first computer for an authorization code.

Advantages of the invention may include one or more of the following. Having a firewall computer provide tunnel records, including secret keys, eliminates the need for a separate "trusted computer". Additionally, a user is not required to generate tunnel records in order to communicate with a firewall computer.

Other advantages and features will become apparent from the following description and from the claims.

DESCRIPTION

FIG. 1 is a block diagram of two computers connected together through two networks.

FIG. 2 is a block diagram of two firewall computers and networks.

FIG. 3 is a block diagram of a computer including a security network driver.

FIG. 4 is a flow chart of encapsulation and encryption.

FIGS. 5 and 6 are block diagrams of network packets.

FIG. 7 is a flow chart of decryption and decapsulation.

FIG. 8 is a block diagram of virtual tunnels.

FIG. 9 is a block diagram of a computer network.

FIG. 10 is a flow chart of tunnel record generation.

FIG. 11 is a flow chart of tunnel record updating.

As seen in FIG. 3, security network driver software 72 is inserted between network protocol TCP/IP 22 and corresponding network driver 40. The security network driver encrypts information before it is sent on the network by the network driver and decrypts information received from the network by the network driver before the information is sent to the network protocol. As a result, after choosing a security network driver with the required security features, users may freely choose among available applications and network protocols regardless of the required level of security and regardless of the available encryption/decryption libraries and without having to compromise their security needs. Moreover, the chosen applications and network protocols need not be modified. To change the level of security, the user may simply choose another security network driver or modify the current security network driver.

Generally, a computer's operating system software defines a "road map" indicating which applications may

communicate with each other. To insert a security network driver between a network protocol and a network driver, the road map is altered. The vendor of the operating system software may make the road map available or the road map may be determined through observation and testing. Once the road map is altered, functions such as send and receive, between the network protocol and the network driver are diverted to the network security driver to encrypt data before it is sent on the network and to decrypt data when it is received from the network.

Referring to FIGS. 3 and 4, as an example, to send data from computer 16 to computer 18 on the internet, Telnet 10 issues (step 60) a send call to TCP/IP 22 through network protocol API 28. The send call includes a network packet 62 (FIG. 5) having a header 64 and data 66. The header includes information such as the addresses of the source and destination computers and the type of application that sent the data. The network protocol then issues (step 68) a send call to the network driver API which, in accordance with the altered road map, issues (step 70) a send call to a security network driver (SND) 72.

The security network driver issues (step 74) an encapsulate call to an encapsulate/decapsulate library 76 through an API 77. In one example, the encapsulate/decapsulate library uses the swIPe IP Security Protocol created by J. Ioannidis of Columbia University and M. Blaze of AT&T™, Inc. which is described in an Internet Draft dated Dec. 3, 1993 and incorporated by reference. Referring also to FIG. 6, the encapsulate call generates a new network packet 78 in accordance with the swIPe protocol. The new packet includes a header 80, a swIPe protocol header 82, and data 84. According to options within the swIPe protocol, header 80 may be the original header 64 (FIG. 5), in which case, data 84 is the original data 66, or header 80 may be a new header including the address of a source firewall computer, e.g., computer 16 (FIG. 2), and a destination computer which may also be a firewall computer, e.g., 18. Where header 80 is a new header, data 84 includes the entire original network packet 62 (FIG. 5).

After encapsulating the network packet, the security network driver issues (step 88, FIG. 4) an encryption call to an encryption/decryption library 90 (FIG. 3) through an API 91. Library 90 encrypts a portion 92 of the encapsulated network packet including data 84 and part of swIPe protocol header 82. Header 80 (FIG. 6) is not encrypted. Thus, if, according to options within the swIPe protocol, header 80 is the original header 64 (FIG. 5), then the addresses of the source and destination computers are visible on the internet. On the other hand, if header 80 is a new header including the addresses of firewall computers, then the addresses of internal source and destination computers are encrypted and not visible on the internet.

Library 90 may be of the type sold by RSA Data Security™, Inc. of Redwood City, Calif. and may encrypt the data according to an RSA algorithm such as RC2 or RC4 or according to a federal information processing standard (FIPS) such as data encryption standard (DES).

The security network driver then issues (step 94) a send call, including the encapsulated/encrypted network packet, to the API, and the API, in accordance with the altered road map, issues (step 96) a send call to a network driver, e.g., network driver 40. The network driver then causes hardware 46 to transmit (step 98) the encapsulated/encrypted network packet on the network.

Referring to FIGS. 3 and 7, the network drivers of each computer 16, 18 (FIGS. 2 and 3) maintain a database of

addresses to which they will respond. For example, when network driver 40 receives (step 100) a properly addressed network packet from network 20, the network driver issues (step 102) a receive call to corresponding network protocol API 34. In accordance with the altered road map, the API issues (step 104) a receive call to security network driver (SND) 72 which issues (step 106) an authorization call to encapsulate/decapsulate library 76 through API 77. Library 76 examines the unencrypted portion of swIPe header 82 (FIG. 6) to determine (step 108) whether it is proper. If it is not proper, an error (step 110) is flagged.

If the header 82 is not a swIPe header, then the security network driver issues a receive call to the API including the unaltered packet.

If the swIPe header is proper, the security network driver issues (step 112) a decryption call to encryption/decryption library 90 through API 91. A portion of the unencrypted swIPe protocol header includes a policy identification (id) field 113. The policy id field indicates the encryption algorithm used to encrypt the data. Library 90 uses a secret key that was previously exchanged between the computers and the encryption algorithm to decrypt data 84.

After decryption, the security network driver issues (step 114, FIG. 7) a digital signature check call to encapsulate/decapsulate library 76. The swIPe protocol header includes a digital signature 86. The digital signature is a unique number calculated using the data in the network packet, the secret key, and a digital signature algorithm. Library 76 recalculates the digital signature and compares (step 116) it to digital signature 86 in the network packet. If the network packet is tampered with during transmission and any data within the packet is changed, then the digital signature in the packet will not match the digital signature generated by the receiving computer and an error (step 118) will be flagged.

If the signatures match, then the security network driver issues (step 120) a receive call to the API which issues (step 121) a receive call to the TCP/IP network protocol including only the original network packet 62 (FIG. 5, data 66 and addresses of the source and destination computers 64). If (step 122) the network packet is destined for computer 16, then TCP/IP issues (step 124) a receive call to an application 10, 12 and if the network packet is destined for a computer on an internal network, e.g., computer 54 (FIG. 2) on network 50, then TCP/IP issues (step 126) a receive call to internal network driver 53 which then sends (step 128) the data to the internal computer.

Referring to FIG. 8, the policy id field may be used to create virtual tunnels 140, 142 between firewall computers 146, 148 on internet 152. When computer 146 receives a network packet, it checks the policy id to determine which "tunnel" the packet came through. The tunnel indicates the type of encryption algorithm used to encrypt the packet.

Multiple tunnels 140, 142 may connect two computers 146, 148 and each tunnel may use a different encryption algorithm. For example, tunnel 140 may use the RC2 encryption algorithm from RSA Data Security™, Inc. while tunnel 142 uses the FIPS DES encryption algorithm. Because the RC2 encryption algorithm is less secure and requires less computer processing time than the FIPS DES standard, users may send a larger number of network packets requiring less security over tunnel 140 as opposed to tunnel 142. Similarly, predetermined groups of users or computers may be restricted to sending their packets over particular tunnels (effectively attaching a packet filter to each tunnel).

The tunnel may also indicate where the packet is to be sent. Primary firewall computers 16, 18 store information

about the internal path of each tunnel in a tunnel database. When computer 146 receives a packet whose policy id indicates that the packet came through a tunnel that ends at computer 146, e.g., tunnel 142, computer 146 decapsulates and decrypts the packet and sends the decrypted packet over internal network 154 to the proper destination computer in accordance with the decrypted destination address. When computer 146 receives a packet whose policy id indicates that it came through a tunnel that does not end with computer 146, e.g., tunnel 140, computer 146 does not decapsulate and decrypt the packet. Instead, computer 146 sends the encrypted packet to internal firewall computer 158 in accordance with the tunnel database.

Internal firewall computer 158 also has a tunnel database in which the internal path of any tunnels connected to computer 158 are stored. As a result, when computer 158 receives a packet whose policy id indicates that it came through a tunnel that ends with computer 158, e.g., tunnel 140, it decapsulates and decrypts the packet according to the policy id and sends the decrypted packet over internal network 160 to computer 162 in accordance with the decrypted destination address.

The only addresses visible on the internet and on internal network 154 are the addresses of the firewall computers 146, 148, and 158. The address of internal computer 162 and, hence, the network topology of network 160 are protected on both the internet and internal network 154.

The tunnel databases provide the firewall computers 146, 148, and 158 with information as to the internal path of the tunnels. Thus, if computer 162 was another firewall computer, computer 146 may modify the destination address of packets received on tunnel 140 to be the address of computer 162 to cause computer 158 to send the packet directly to computer 162 without checking the policy id field.

Encapsulating/decapsulating and encrypting/decrypting network packets may require a large portion of a computer's processing power. Creating virtual tunnels using the policy id field allows the encapsulating/decapsulating and encrypting/decrypting of network packets to be spread across several computers. For example, computer 146 may decapsulate and decrypt network packets destined for computers connected to internal network 154 while computer 158 may decapsulate and decrypt network packets destined for computers connected to internal networks 154 and 160. Similarly, computer 146 may encapsulate and encrypt network packets sent from computers connected to internal network 154 while computer 158 may encapsulate and encrypt network packets sent from computers connected to internal networks 154 and 160.

The Kerberos Key Distribution Center components of Kerberos Network Authentication System created under project Athena at Massachusetts Institute of Technology, defines one method of providing computers with secret keys. Referring to FIG. 9, computer 130 is termed the "trusted" computer, and before computers 132 and 134 may transfer encrypted data to each other over network 136, both computers send a request to trusted computer 130 for a secret key. For a more detailed description of the Kerberos Key Distribution Center, see RFC1510 (request for comment) "Kerberos Network Authentication Service" by J. Kohl & B. Neuman, Sep. 10, 1993, which is incorporated by reference.

Referring back to FIG. 2, to transfer secure (i.e., encapsulated and/or encrypted) network packets between two computers, operators of the two computers may verbally exchange a secret key for each tunnel between the comput-

ers and then manually initialize the computers to transfer data by generating a tunnel record including a secret key for each tunnel between the two computers. Firewall computers are typically managed by skilled technicians capable of generating tunnel records. Typical users have non-firewall computers and may wish to transfer encapsulated/encrypted data with a firewall computer. To avoid requiring that a typical user generate tunnel records and instead of having a separate trusted computer provide secret keys to two computers, a firewall computer 16, 18 may provide secret keys to other computers.

Referring also to FIG. 10, when a user wishes to transfer packets between his/her computer and a firewall computer, the user requests (step 170) a password (a onetime pad) from the firewall operator. The operator then generates (step 172) tunnel records for each tunnel over which the user's computer and the firewall computer may transfer network packets. The operator also stores (step 174) the password given to the user on the firewall computer. The user installs (step 176) the security network driver (SND) software on his/her computer and runs (step 178) a configuration program. The configuration program prompts (step 180) the user for the password and sends (step 182) a configuration request to the firewall computer.

The firewall computer identifies (step 184) the user's computer as the sender of the request and notifies the user's computer of the available tunnels by sending (step 186) the complete tunnel records, including secret keys, associated with each tunnel to the user's computer. The tunnel records are sent through network packets that are encrypted using the password and the encryption algorithm. Afterwards, the firewall deletes (step 188) the password, and further network packets are transmitted between the two computers through the available tunnels and encrypted according to the secret key associated with each tunnel.

Referring to FIG. 11, generally, each time the user's computer accesses (step 190) the internet, a new internet address is assigned. The firewall computer needs to know the new address in order to update the tunnel records. To notify the firewall computer of the new internet address, each time the user's computer accesses the internet, the configuration software issues (step 192) a connect request to the firewall computer. The firewall computer identifies (step 194) the computer and may prompt the user for a user name and a user password. If the user name and password are authorized (step 196), the firewall updates (step 198) the tunnel records with the internet address sent as part of the connect request. The configuration software also updates (step 200) the non-firewall computer's tunnel records with the computer's new internet address.

Other embodiments are within the scope of the following claims.

For example, instead of encapsulating the network packets using the swIPe protocol header, other internet security algorithms may be used.

Although the security network driver was described with respect to send and receive functions, APIs from different manufacturers, for example, Sun™, Inc. and Microsoft™, Inc., include a variety functions, and the security network driver is designed to respond to each possible function.

The security network driver may also be simultaneously connected to multiple network protocols, e.g., both TCP/IP 22 and IPX 24, as shown in FIG. 3.

7

What is claimed is:

1. A method for enabling computers to communicate using encrypted network packets, comprising:
 - 5 sending a configuration request over a network from a first computer to a second computer;
 - providing a temporary configuration password to the first computer;
 - 10 encrypting, in accordance with the temporary configuration password, tunnel record information that includes a secret tunnel encryption key assigned to a tunnel between the first computer and the second computer; and
 - 15 sending the tunnel record information over the network from the second computer to the first computer.
2. The method of claim 1, further comprising, before sending a configuration request over a network:
 - generating, on the second computer, the tunnel record information.
3. The method of claim 1, further comprising:
 - 20 after receiving the tunnel record information from the second computer, sending a network packet over the network through a virtual tunnel, the network packet being encrypted in accordance with the secret tunnel encryption key in the tunnel record information corresponding to the virtual tunnel.
 - 25
4. The method of claim 1, wherein the second computer comprises a firewall computer.
5. The method of claim 1, wherein the network comprises a public network.

8

6. A method for updating a tunnel record, comprising:
 - sending a connection request from a first computer to a second computer;
 - 5 authenticating the first computer; and
 - updating a tunnel record corresponding to the connection request with the first computer's network address.
7. The method of claim 6, wherein authenticating includes:
 - 10 identifying the first computer.
8. The method of claim 7, wherein authenticating further includes:
 - 15 prompting the first computer for an authorization code.
9. A method for enabling computers to communicate using encrypted network packets, comprising:
 - generating a temporary configuration password on a firewall computer;
 - 20 sending a configuration request over a public network from a second computer to the firewall computer;
 - 25 sending tunnel record information that includes a tunnel encryption key over the public network from the firewall computer to the second computer, the tunnel record information being encrypted in accordance with the temporary configuration password; and
 - deleting the temporary configuration password on the firewall computer.

* * * * *