

# **EXHIBIT D**



US006488390B1

(12) **United States Patent**  
**Lebens et al.**

(10) **Patent No.:** **US 6,488,390 B1**  
(45) **Date of Patent:** **\*Dec. 3, 2002**

(54) **COLOR-ADJUSTED CAMERA LIGHT AND METHOD**

(75) Inventors: **Gary A. Lebens**, Chaska, MN (US);  
**Charles T. Bourn**, Minnetonka, MN (US);  
**Charles A. Lemaire**, Apple Valley, MN (US)

(73) Assignee: **PPT Vision, Inc.**, Eden Prairie, MN (US)

(\*) Notice: Subject to any disclaimer, the term of this patent is extended or adjusted under 35 U.S.C. 154(b) by 0 days.

This patent is subject to a terminal disclaimer.

(21) Appl. No.: **09/978,760**

(22) Filed: **Oct. 16, 2001**

**Related U.S. Application Data**

(60) Continuation of application No. 09/627,268, filed on Jul. 28, 2000, now Pat. No. 6,305,818, which is a division of application No. 09/044,559, filed on Mar. 19, 1998, now Pat. No. 6,095,661.

(51) **Int. Cl.**<sup>7</sup> ..... **F21V 9/00**

(52) **U.S. Cl.** ..... **362/231**; 362/184; 362/185;  
362/208; 362/183; 362/800; 362/234; 362/11;  
362/13

(58) **Field of Search** ..... 362/157, 183,  
362/159, 184, 208, 800, 249, 11, 13, 234;  
315/224, 307, 291, 312, 360, 362

(56) **References Cited**

**U.S. PATENT DOCUMENTS**

3,069,654 A	12/1962	Hough	340/146.3
3,663,752 A	5/1972	Froschle	
4,208,579 A	6/1980	Scervo et al.	250/227
4,212,073 A	7/1980	Balasubramanian	364/562
4,290,095 A	9/1981	Schmidt	362/191
4,346,329 A	8/1982	Schmidt	315/51

(List continued on next page.)

**FOREIGN PATENT DOCUMENTS**

EP	0356680	3/1990	
EP	0638801	2/1995	..... G01N/21/88
WO	91/06846	5/1991	
WO	98/02716	1/1998	..... G01B/11/03

**OTHER PUBLICATIONS**

“Copy of U.S. application Ser. No. 08/825,774 entitled High Speed Digital Video Serial Link”, 33 pgs., (Apr. 2, 1997).

(List continued on next page.)

*Primary Examiner*—Stephen Husar

*Assistant Examiner*—Bertrand Zeade

(74) *Attorney, Agent, or Firm*—Schwegman, Lundberg, Woessner & Kluth, P.A.

(57) **ABSTRACT**

Improved method and apparatus for hand-held portable illumination. A flashlight and corresponding method are described. The flashlight includes a housing, a plurality of LEDs, and an electrical circuit that selectively applies power from the DC voltage source to the LED units, wherein the flashlight is suitable for handheld portable operation by a user. In one embodiment, the first electrical circuit further includes a control circuit for maintaining a predetermined light output level of the LED units as a charge on a battery varies. In another embodiment, the control circuit maintains an average predetermined light output level of the LED units as the charge on the battery cell varies by changing a pulse width or frequency as the charge on the battery cell varies to maintain a given average light output. Another aspect provides an illumination source that includes a light-emitting diode (LED) housing including one or more LEDs, and a control circuit that selectively applies power from a source of electric power to the LEDs, the control circuit substantially maintaining a light output characteristic of the LEDs as a voltage of the voltage source varies over a range that would otherwise vary the light output characteristic. Still another aspect provides an illumination source including a light-emitting diode (LED) housing including one or more LEDs; and a control circuit that selectively applies power from a source of electric power to the LEDs, thus maintaining or controlling a light output color spectrum of the LEDs.

**40 Claims, 11 Drawing Sheets**

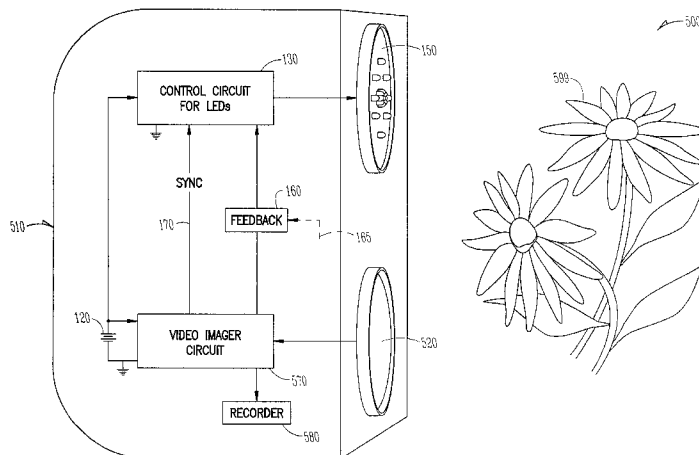

## U.S. PATENT DOCUMENTS

4,509,266 A	4/1985	Cusack .....	33/174 L	5,636,025 A	6/1997	Bieman et al. ....	356/374
4,592,147 A	6/1986	Herman .....	33/366	5,646,733 A	7/1997	Bieman .....	356/376
4,639,139 A	1/1987	Wyant et al. ....	356/359	5,680,215 A	10/1997	Huber et al. ....	356/371
4,641,972 A	2/1987	Halioua et al. ....	356/376	5,745,176 A	4/1998	Lebens .....	348/370
4,743,773 A	5/1988	Katana et al. ....	250/566	5,825,495 A	10/1998	Huber .....	356/371
4,820,229 A	4/1989	Spraggins .....	446/26	5,828,449 A	10/1998	King et al. ....	356/237
4,831,504 A	5/1989	Nishizawa et al. ....	362/100	5,838,247 A	11/1998	Bladowski .....	340/815.45
4,877,326 A	10/1989	Chadwick et al. ....	356/394	5,890,794 A	4/1999	Abtahi et al. ....	362/294
4,882,498 A	11/1989	Cochran et al. ....	250/571	6,084,631 A	7/2000	Tonkin et al. ....	248/212
4,893,815 A	1/1990	Rowan .....	273/84	6,095,661 A	8/2000	Lebens et al. ....	362/184
4,914,289 A	4/1990	Nguyen et al. ....	250/223 B	6,305,818 B1 *	10/2001	Lebens et al. ....	362/184
4,962,347 A	10/1990	Burroughs et al. ....	320/48				
4,964,023 A	10/1990	Nishizawa et al. ....	362/100				
4,965,665 A	10/1990	Amir .....	358/101				
4,967,284 A	10/1990	Yoshida et al. ....	358/300				
4,972,093 A	11/1990	Cochran et al. ....	250/572				
4,974,138 A	11/1990	Negishi .....	362/347				
4,978,857 A	12/1990	Juengel .....	250/551				
5,010,412 A	* 4/1991	Garriss .....	348/371				
5,015,918 A	5/1991	Copeland .....	315/76				
5,051,825 A	9/1991	Cochran et al. ....	358/106				
5,058,982 A	10/1991	Katzir .....	385/33				
5,059,013 A	10/1991	Jain .....	359/503				
5,060,065 A	10/1991	Wasserman .....	358/106				
5,065,035 A	11/1991	Juengel .....	250/551				
5,072,127 A	12/1991	Cochran et al. ....	250/572				
5,085,502 A	2/1992	Womack et al. ....	356/376				
5,172,005 A	12/1992	Cochran et al. ....	250/57				
5,179,335 A	1/1993	Nor .....	320/21				
5,179,474 A	1/1993	Bailey et al. ....	359/798				
5,279,513 A	1/1994	Connelly .....	446/219				
5,299,227 A	3/1994	Rose .....	375/1				
5,354,977 A	10/1994	Roustaeci .....	235/472				
5,355,221 A	10/1994	Cohen et al. ....	356/359				
5,398,113 A	3/1995	de Groot .....	356/360				
5,424,927 A	6/1995	Schaller et al. ....	362/157				
5,457,492 A	10/1995	Sasaki et al. ....	348/126				
5,465,152 A	11/1995	Bilodeau et al. ....	356/371				
5,468,950 A	11/1995	Hanson .....	235/472				
5,546,189 A	8/1996	Svetkoff et al. ....	356/376				
5,561,525 A	10/1996	Toyonaga et al. ....	356/360				
5,604,550 A	2/1997	White .....	396/429				

## OTHER PUBLICATIONS

“Edmund Scientific Company 1993 Annual Referencing Catalog, Cylinder Lenses (CYL)”, *catalog pg. 47*.

“Hewlett Packard Optotronics Designer’s Catalog, Technical Data entitled High power AlInGaP Amber and Reddish-Orange Lamps”, *pgs. 3–24 through 3–29, 1993*.

Ballard, D.H., “Generalizing the Hough Transform to Detect Arbitrary Shapes”, *Pattern Recognition, 13 (2)*, Pergamon Press, pp. 183–194, (1981).

Davies, E.R., *Machine Vision: Theory, Algorithms, Practicalities, 2nd Edition*, Academic Press, San Diego, pp. 195–210, (1997).

Gennert, M.A., et al., “Uniform Fontal Illumination of Planar Surfaces: where to place the lamps”, *Optical Engineering*, vol. 32, No. 6, pp. 1261–1271, (Jun. 1993).

Novini, A., “Fundamentals of machine Vision Lighting”, *Electro Conference Record, New York, NY*, pp. 435–443, (1993).

Uber, G.T., “Illumination Methods for Machine Vision”, *SPIE vol. 728 Optics, Illumination, and Image Sensing for Machine Vision*, pp. 93–102, (1986).

Yang, H.S., et al., “Determination of the Identity, Position and Orientation of the Topmost Object in a Pile: Some Further Experiments”, *IEEE International Conference on Robotics and Automation, 1*, San Francisco, CA, 293–298, (1986).

\* cited by examiner

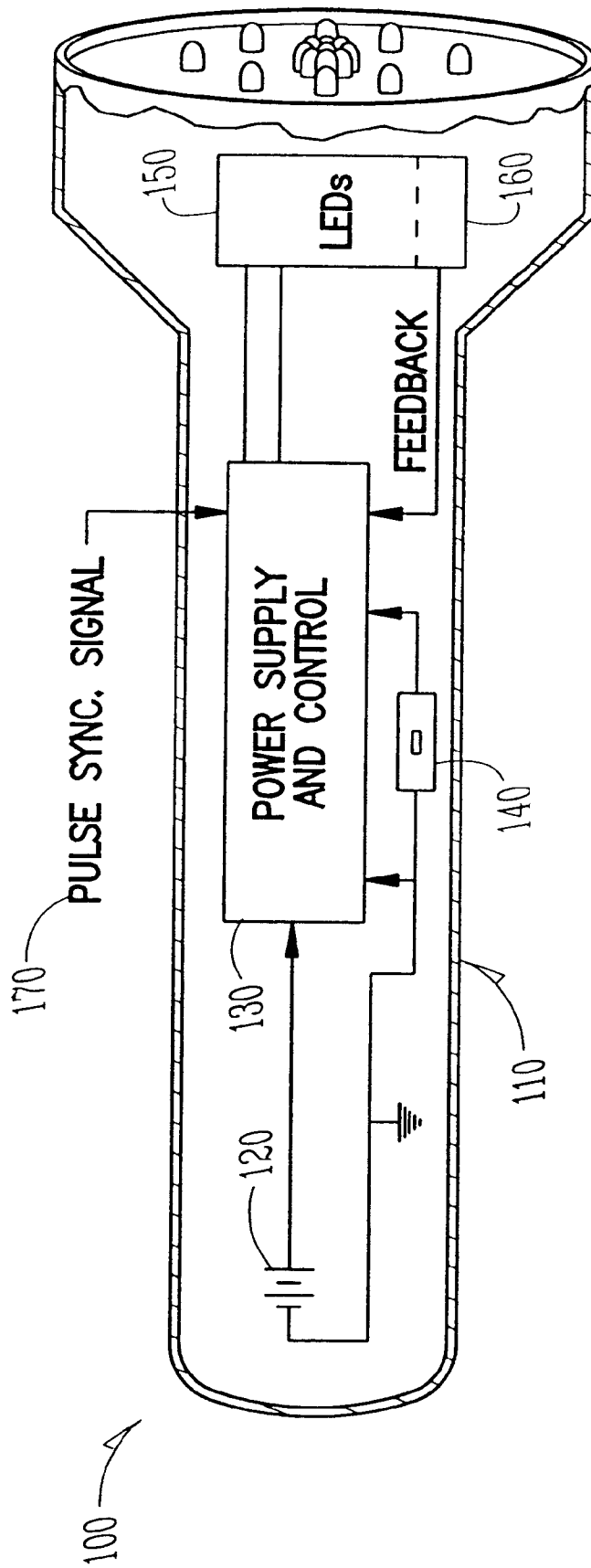

Fig. 1

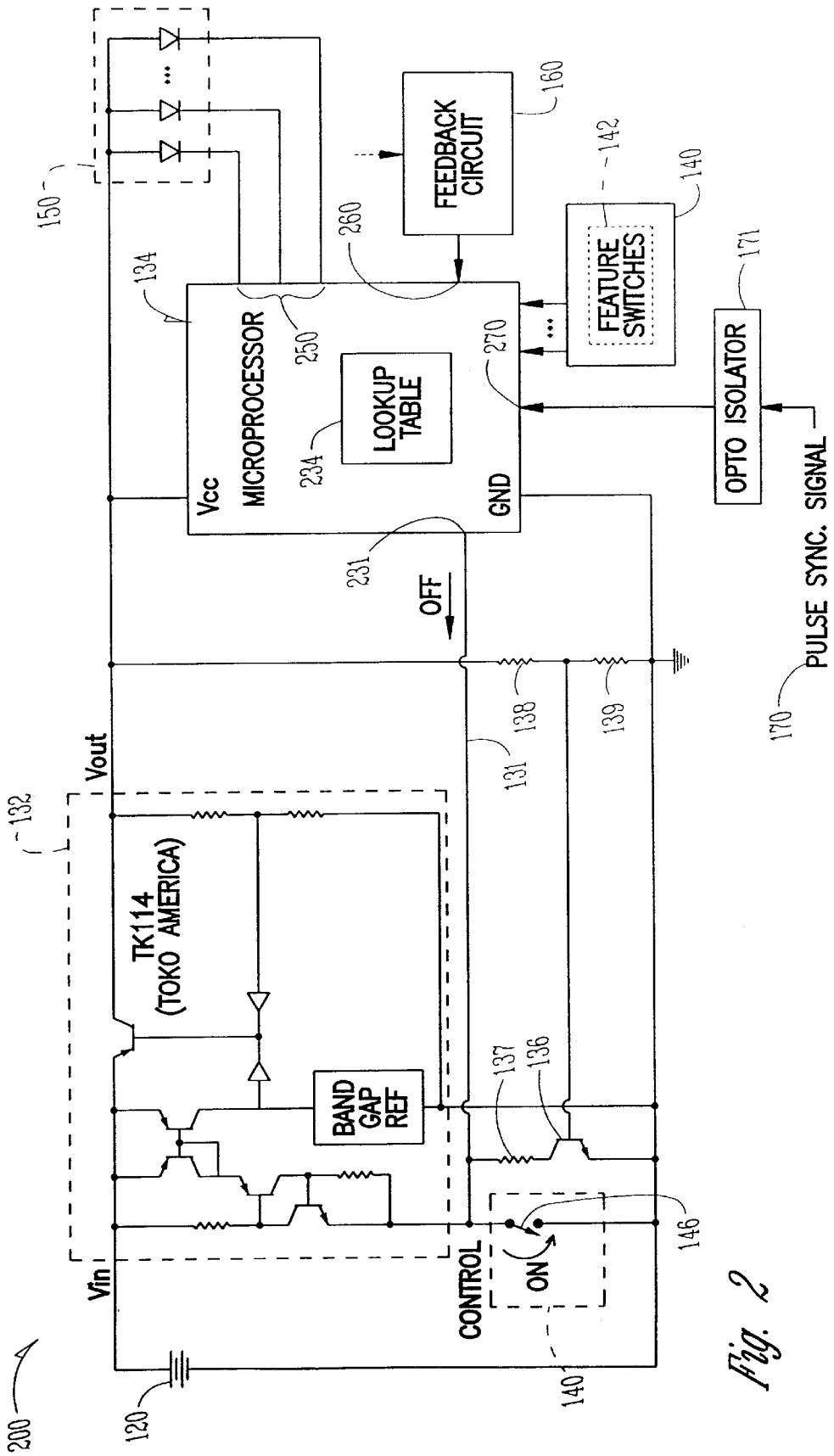

Fig. 2



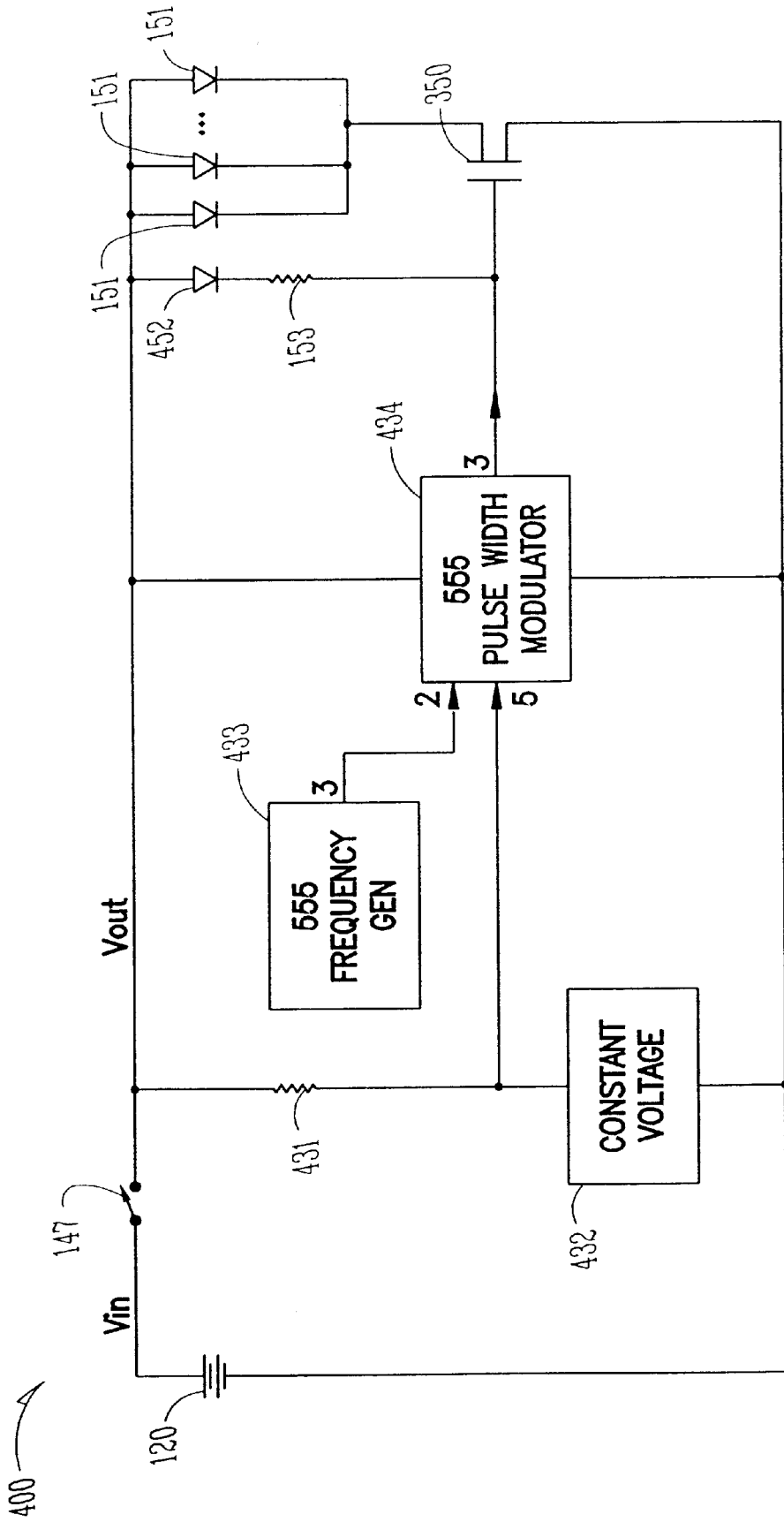

Fig. 4

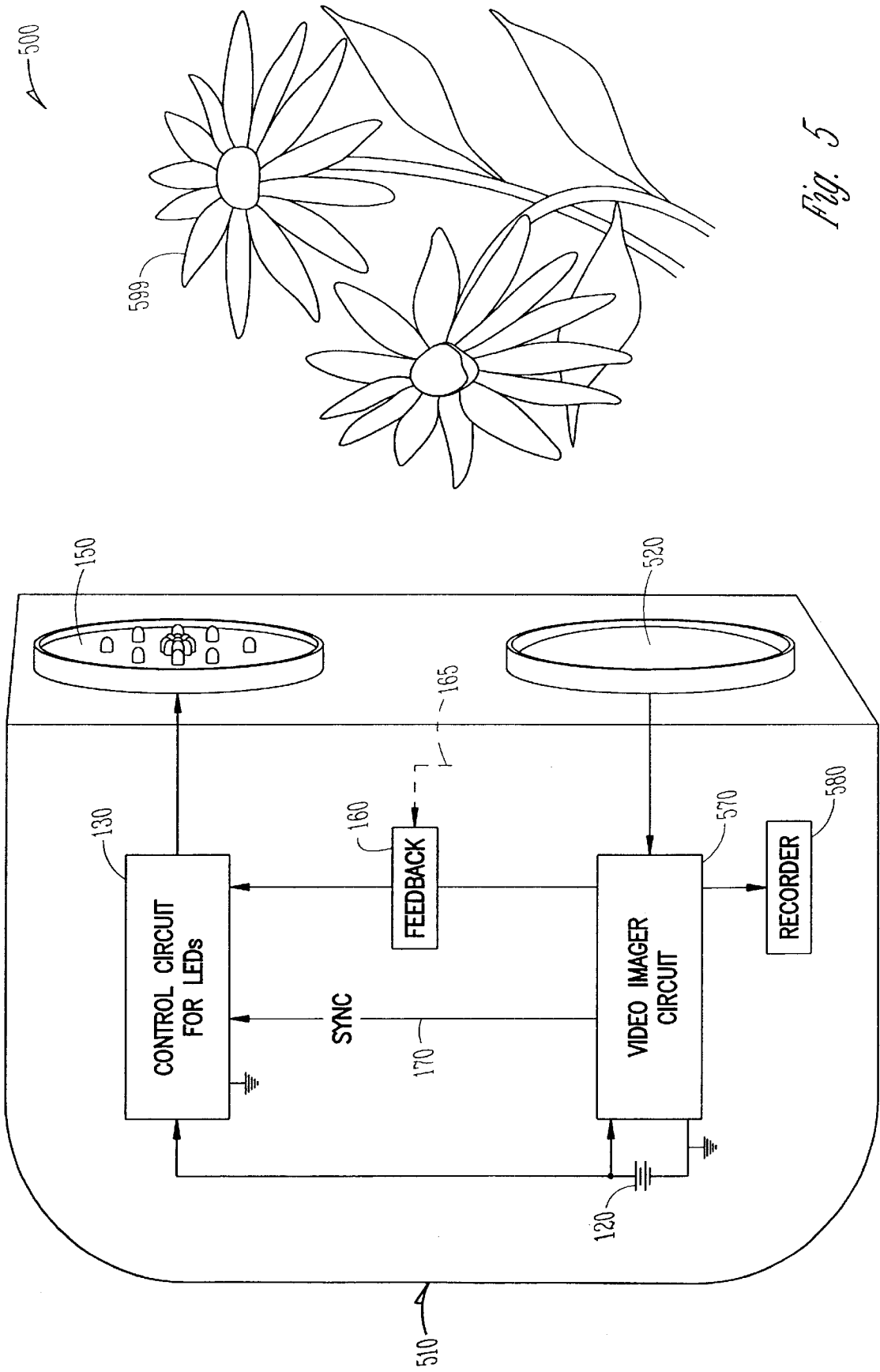
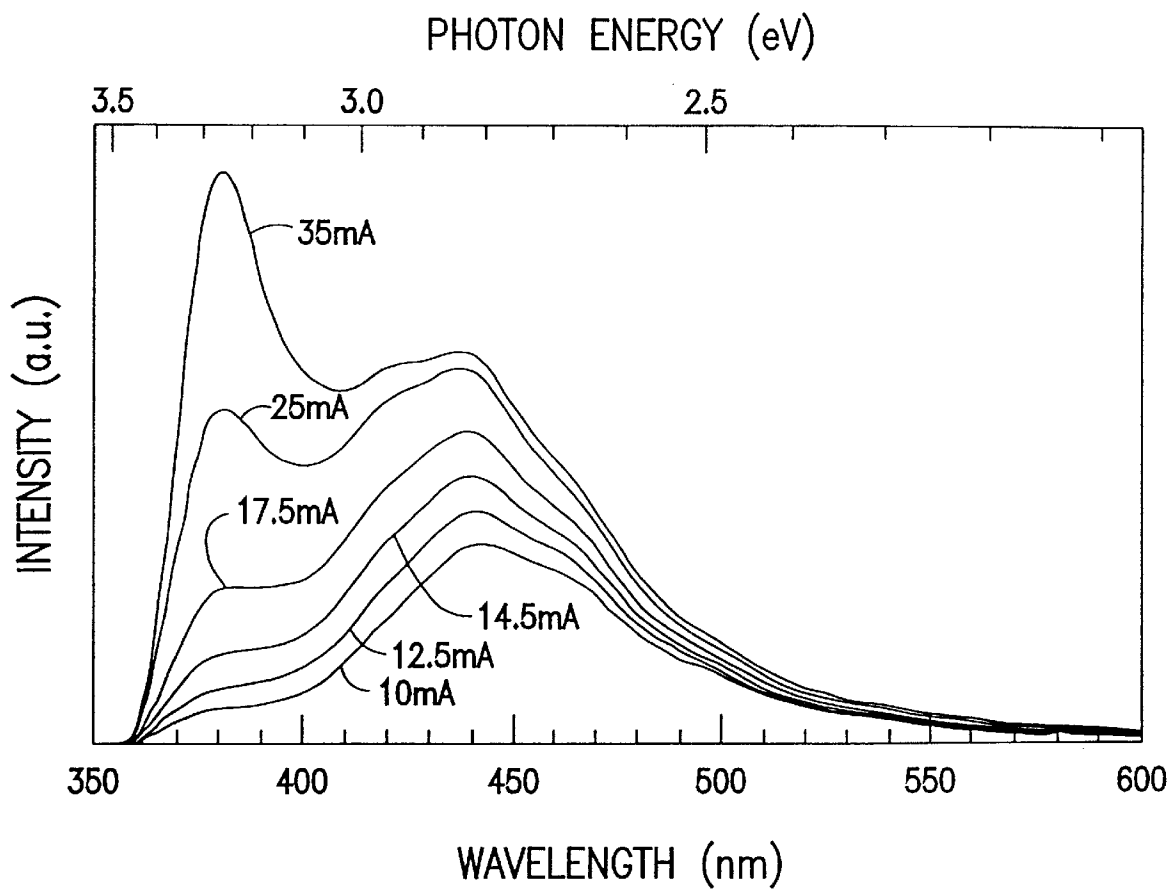

Fig. 5





*Fig. 6*

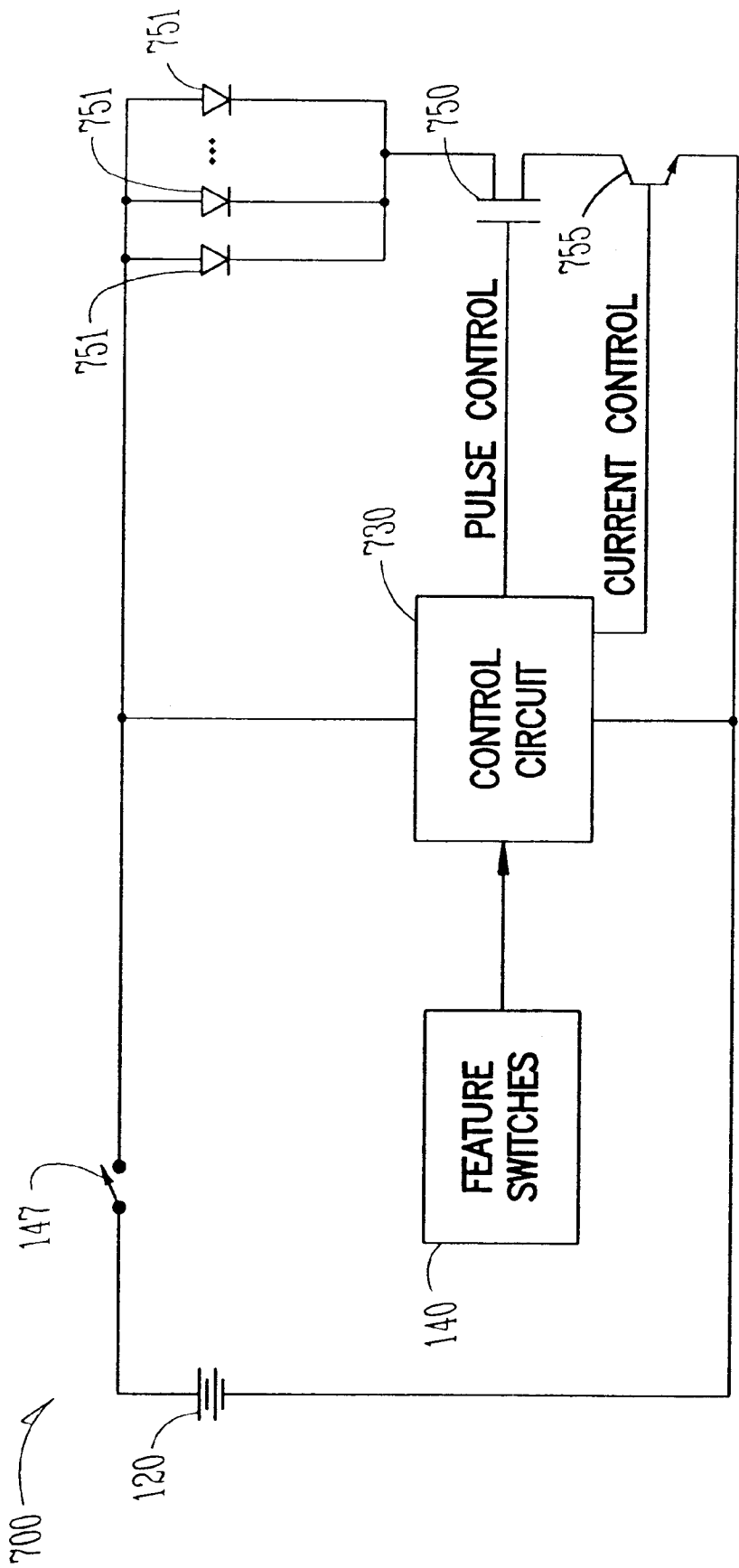

Fig. 7

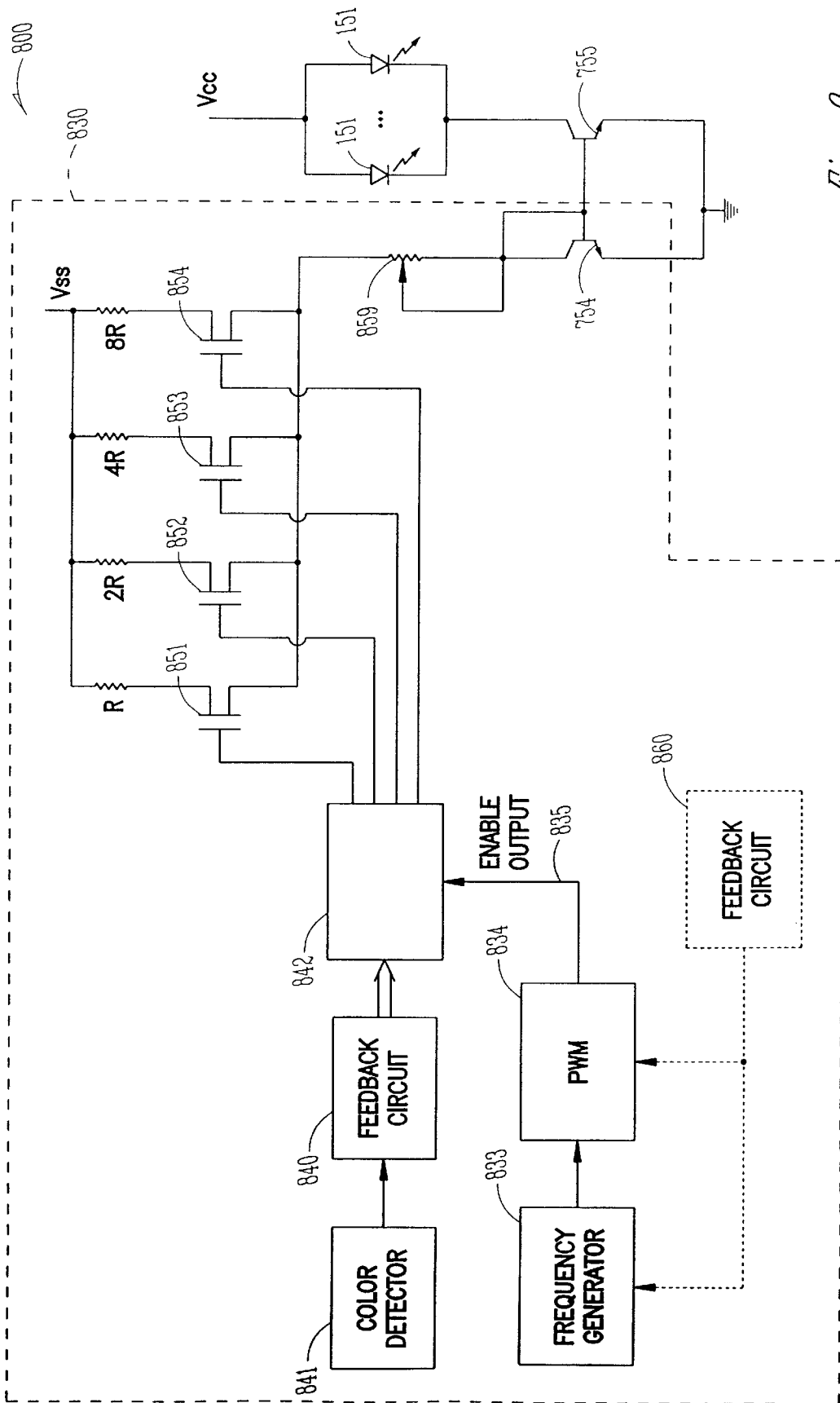
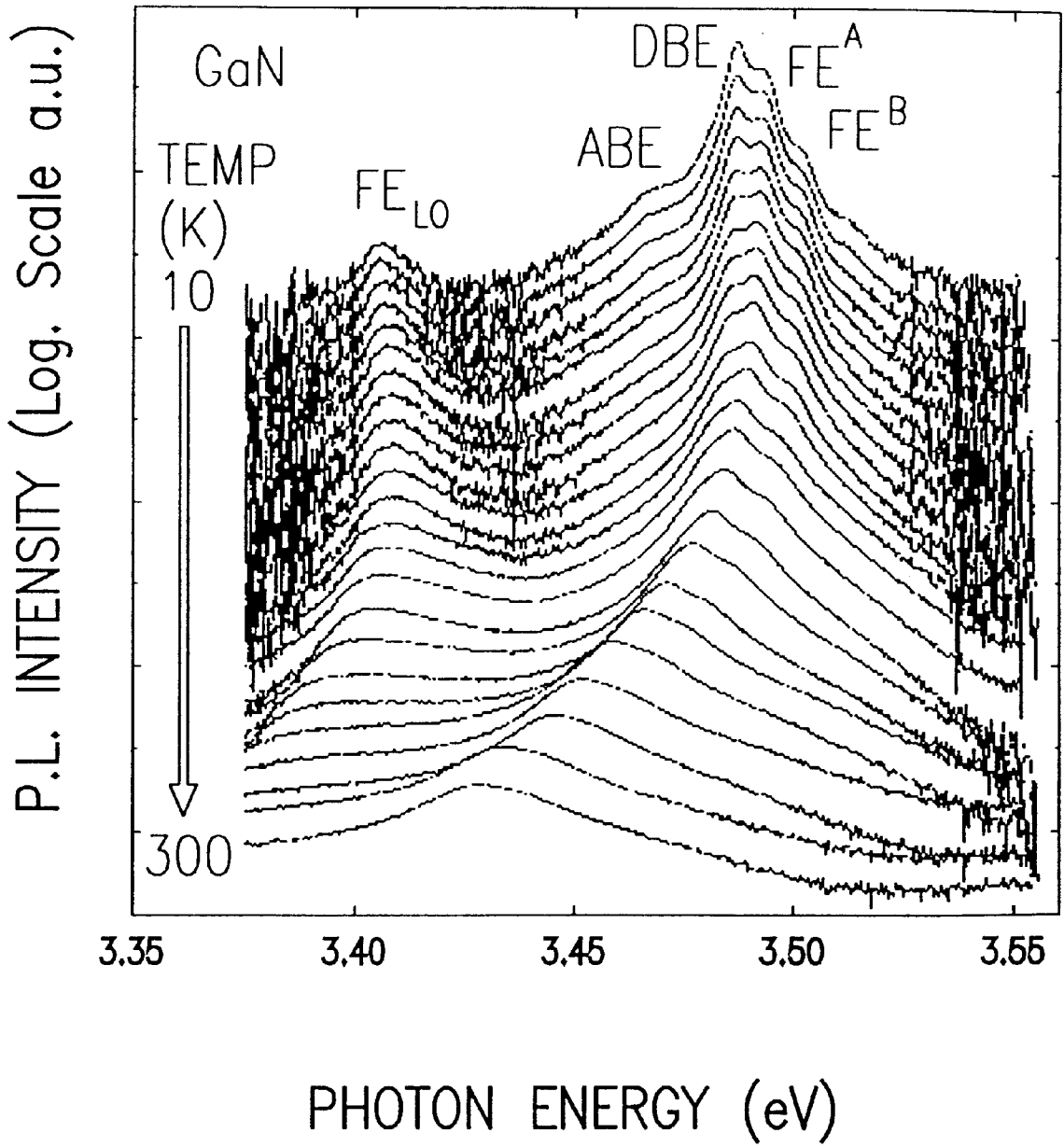

Fig. 8



*Fig. 9*

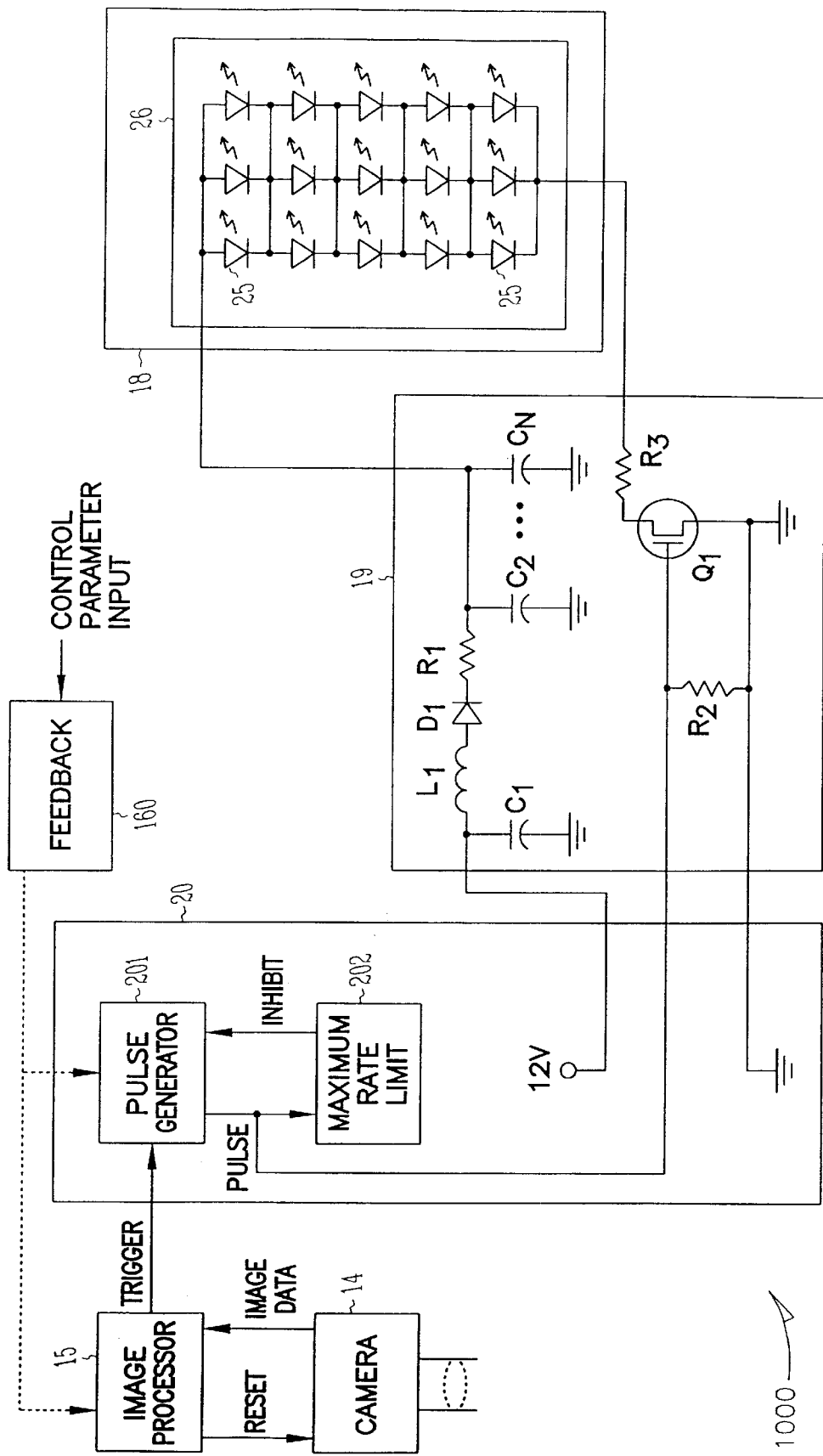

Fig. 10

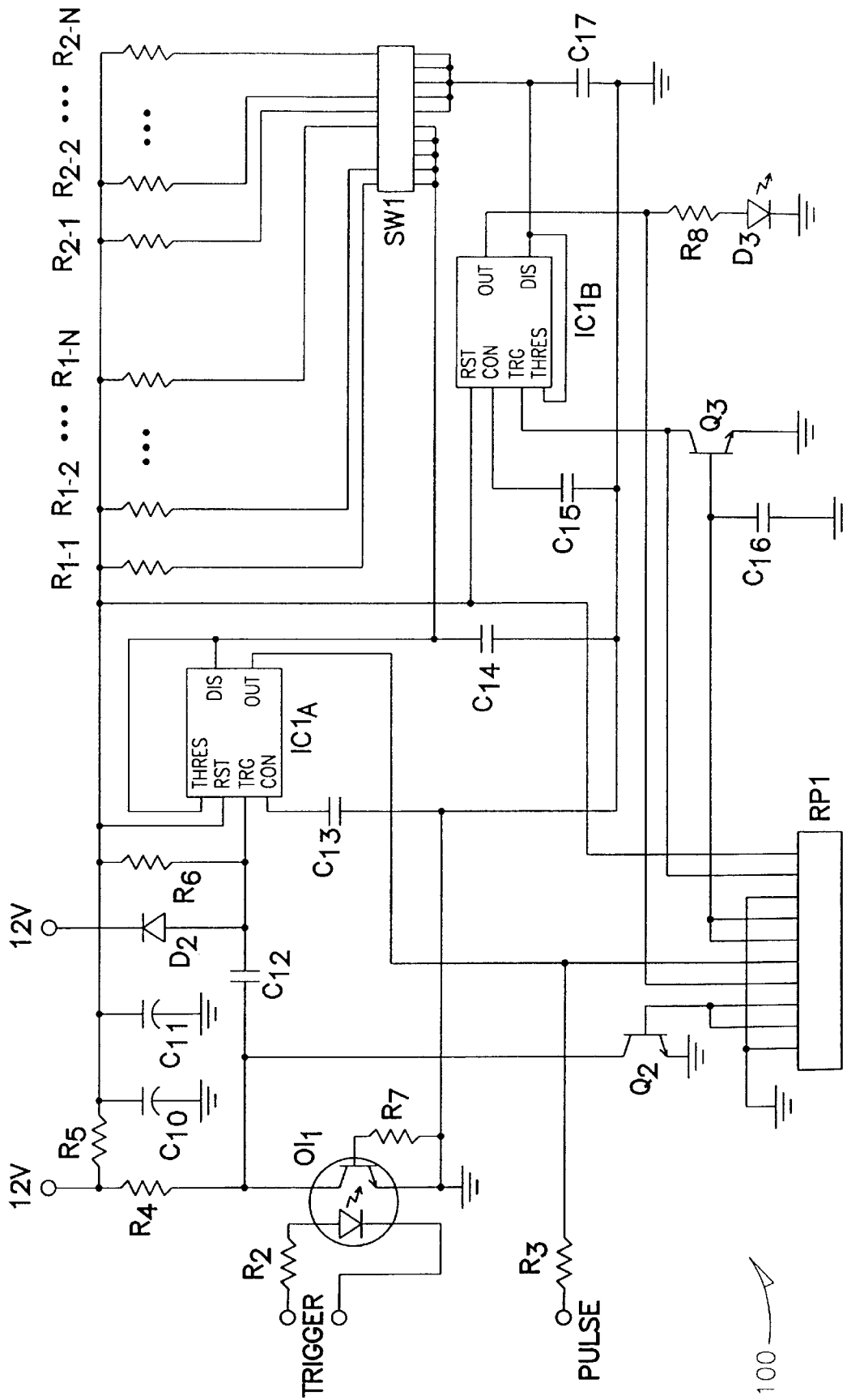

Fig. 11

## COLOR-ADJUSTED CAMERA LIGHT AND METHOD

This application is a continuation of U.S. application Ser. No. 09/627,268, filed Jul. 28, 2000 (U.S. Pat. No. 6,305, 818), which is a divisional of U.S. application Ser. No. 09/044,559, filed Mar. 19, 1998 (U.S. Pat. No. 6,095,661), which applications are incorporated herein by reference.

### FIELD OF THE INVENTION

This invention relates to the field of lighting, and more specifically to a method and apparatus of controlling and powering a solid-state light source such as a light-emitting diode or LED, for a portable battery-powered flashlight.

### BACKGROUND OF THE INVENTION

There is a widespread need for hand-held flashlights and lanterns. One common flashlight includes a two-cell battery for power, an incandescent lamp to emit light, and a simple single-pole switch to connect and disconnect the battery to the lamp. Other flashlights use other numbers of battery cells in order to provide a voltage suitable for various particular conditions. Lanterns often use a fluorescent tube to emit light. Certain keychain fobs use a pair of hearing-aid cells and a red-light light-emitting diode (LED) in order to provide short-range lighting such as might be needed to find a keyhole in the dark.

Battery technology is such that as electrical power is withdrawn from a battery cell, the voltage available across a given current load will decrease. This decreased available voltage across the given load causes reduced light output, gradually dimming the light as the battery charge depletes.

Further, LEDs have voltage, current, and power parameters that must be controlled in order to maximize device life. Commonly, a current-limiting resistor is placed in series with an LED in order that only a portion of the voltage drop from the battery is across the LED and the rest of the voltage drop is across the resistor. This voltage drop and corresponding power loss in the resistor is dissipated as waste heat, which is inefficient for a flashlight which should be designed to emit light.

In addition, it is awkward or difficult to determine the amount of remaining charge in a battery cell, generally requiring removal of the battery from the flashlight in order to measure the remaining charge. In addition, the cost of a separate measurement device can be a negative for this market. Some battery cells today include a built-in liquid-crystal indicator for the charge in the cell, but such a solution requires a separate measurement device/indicator for each battery, and requires removal of the battery from the flashlight in order to perform the measurement and observe the indication of remaining power.

### SUMMARY OF THE INVENTION

The present invention provides a method and apparatus for an L.E.D. flashlight or other LED illumination source. In one embodiment, a flashlight is described. The flashlight includes a flashlight housing suitable for receiving therein and/or mounting thereon at least one DC voltage source such as a battery. The flashlight also includes a light-emitting diode (LED) housing connected to the flashlight housing, the LED housing including a first plurality of LED units that each emit light and have a reflector for collimating the emitted light forwardly therefrom generally along an LED optical axis, the first plurality of LED units including at least

seven individual LED units. The flashlight also includes a first electrical circuit that selectively applies power from the DC voltage source to the LED units, wherein the flashlight is of such compact size and low weight as to be suitable for single-handed portable operation by a user, the flashlight further having a purpose of providing general-purpose illumination.

In one embodiment, the LED optical axes of the first plurality of LED units in the flashlight are substantially parallel to one another. In one such embodiment, the flashlight further includes a second plurality of LED units that each emit light and have a reflector for collimating the emitted light forwardly therefrom generally along an LED optical axis, wherein the LED optical axes of the second plurality of LED units converge or diverge from one another forwardly from the housing.

In another embodiment, an optical spread angle of the first plurality of LED units in the flashlight are substantially equal to one another. In one such embodiment, the flashlight further includes a second plurality of LED units that each emit light and have a reflector for collimating the emitted light forwardly therefrom generally along an LED optical axis, wherein an optical spread angle of the second plurality of LED units are substantially equal to one another, and different than the optical spread angle of the first plurality of LED units.

In yet another embodiment, the LED units are connected in a parallel-series configuration with at least two LED units coupled in parallel to one another and in series with at least one other LED unit, and the DC voltage source includes at least three battery cells connected in series.

In still another embodiment, the first electrical circuit further includes a control circuit for maintaining a predetermined light output level of the LED units as a charge on the battery cell varies. In one such embodiment, the control circuit maintains an average predetermined light output level of the LED units as the charge on the battery cell varies by increasing a pulse width or a pulse frequency as the charge on the battery cell decreases. In another such embodiment, the control circuit maintains an average predetermined light output level of the LED units by measuring a battery voltage and adjusting a pulse width or a pulse frequency or both to maintain the average light output at the predetermined level. In still another such embodiment, the control circuit maintains an average predetermined light output level of the LED units by measuring an average light output and adjusting a pulse width or a pulse frequency or both to maintain the measured average light output at the predetermined level.

Another aspect of the present invention provides a flashlight including: (a) a flashlight housing, the housing being suitable for at least one of receiving therein and mounting thereon at least one DC voltage source that includes at least one battery cell; (b) a light-emitting diode (LED) housing connected to the flashlight housing, the LED housing including one or more first LED units that each emit light and have a reflector for collimating the emitted light forwardly therefrom generally along an LED optical axis; and (c) a first electrical circuit that selectively applies power from the DC voltage source to the LED units, the first electrical circuit further including a control circuit for maintaining a predetermined light output level of the LED units as a charge on the battery cell varies; wherein the flashlight is of such compact size and low weight as to be suitable for single-handed portable operation by a user, the flashlight further having a purpose of providing general-purpose illumination.

In one such embodiment, the first LED units being a first plurality of LED units, wherein the LED optical axes of the

first plurality of LED units are substantially parallel to one another. In another such embodiment, the flashlight-further includes a second plurality of LED units that each emit light and have a reflector for collimating the emitted light forwardly therefrom generally along an LED optical axis, wherein the LED optical axes of the second plurality of LED units converge or diverge from one another forwardly from the housing.

In another such embodiment, the first LED units are a first plurality of LED units, wherein an optical spread angle of the first plurality of LED units are substantially equal to one another. In yet another such embodiment, the flashlight further includes a second plurality of LED units that each emit light and have a reflector for collimating the emitted light forwardly therefrom generally along an LED optical axis, wherein an optical spread angle of the second plurality of LED units are substantially equal to one another, and different than the optical spread angle of the first plurality of LED units.

Another aspect of the present invention provides a method of providing general-purpose illumination of such compact size and low weight as to be suitable for single-handed portable operation by a user, including the steps of: (a) providing one or more first LED units that each emit light and have a reflector for collimating the emitted light forwardly therefrom generally along an LED optical axis; (b) selectively applying power from a DC voltage source to the LED units; and (c) maintaining a predetermined light output level of the LED units as a charge on the battery cell varies by controlling the step (b).

In one embodiment, the step of maintaining maintains an average predetermined light output level of the LED units as the charge on the battery cell varies by increasing a pulse energy or a pulse frequency as the charge on the battery cell decreases. In another embodiment, the step of maintaining maintains an average predetermined light output level of the LED units by measuring a battery voltage and adjusting a pulse width or a pulse frequency or both to maintain the average light output at the predetermined level. In still another embodiment, the step of maintaining maintains an average predetermined light output level of the LED units by measuring a light output and adjusting a pulse energy or a pulse frequency or both to maintain an average light output at the predetermined level.

Yet another aspect of the present invention provides an illumination source, that includes (a) a light-emitting diode (LED) housing including one or more LEDs; and (b) a control circuit that selectively applies power from a source of electric power to the LEDs, the control circuit substantially maintaining a light output characteristic of the LEDs as a voltage of the voltage source varies over a range that would otherwise vary the light output characteristic. In one such embodiment, the light output characteristic that is maintained is light output intensity. In another such embodiment, the control circuit maintains the light output intensity of the LED units as the voltage of the DC voltage source varies by increasing a pulse width, a pulse energy, or a pulse frequency as the voltage of the DC voltage source decreases. In another such embodiment, the control circuit maintains an average predetermined light output level of the LED units by measuring a voltage and adjusting a pulse energy or a pulse frequency or both to maintain the average light output at the predetermined level. In yet another such embodiment, the control circuit maintains an average predetermined light output level of the LED units by measuring an average light output and adjusting a pulse width or a pulse frequency or both to maintain the measured average light output at the predetermined level.

Another aspect of the present invention provides a battery-powered portable flashlight (100) including: a casing (110) suitable to hold a battery; one or more light-emitting devices (LEDs) (150) mounted to the casing; a switch (140) mounted to the casing; and a control circuit (130) coupled to the battery, the LEDs, and the switch, wherein the control circuit drives the LEDs with electrical pulses at a frequency high enough that light produced by the LEDs has an appearance to a human user of being continuous rather than pulsed, and wherein the LEDs have proportion of on-time that increases as remaining battery power decreases. One such embodiment further includes a feedback circuit that controls the pulses so that light intensity produced by the LEDs, as perceived by the human user, is substantially constant across a greater range of battery power or voltage than a corresponding range for which light intensity is equally constant without the feedback circuit. In one such embodiment, the feedback circuit measures a light output of the LEDs. Another such embodiment further includes a battery-voltage-measuring circuit coupled to the control circuit.

Yet another aspect of the present invention provides a method for driving battery-powered portable flashlight (100) having a casing (110), a DC power source mounted to the casing, one or more solid-state light-emitting device (LEDs) (150) mounted to the casing, the method including the steps of: receiving input from a user; and based on the received input, generating a series of pulses to drive the LEDs such that the LEDs have proportion of on-time that increases as remaining battery power decreases.

Still another aspect of the present invention provides an illumination source including (a) a light-emitting diode (LED) housing including one or more LEDs; and (b) a control circuit that selectively applies power from a source of electric power to the one or more LEDs, the control circuit maintaining a predetermined light output color spectrum of the one or more LEDs as a voltage of the source of electric power varies. In one such embodiment, the one or more LEDs comprise one or more LEDs having a first characteristic color spectrum output and one or more LEDs having a second characteristic color spectrum output, the first characteristic color spectrum output different from the second characteristic color spectrum output, and the control circuit controls a pulse characteristic in order to control the proportion of light output having the first characteristic color spectrum output to that having the second characteristic color spectrum output. In another such embodiment, the one or more LEDs comprise one or more LEDs having a characteristic color spectrum output that varies based on applied current, and the control circuit controls a pulse current in order to control the characteristic color spectrum output.

Yet another aspect of the present invention provides an illumination source that includes (a) a light-emitting diode (LED) housing including one or more LEDs; and (b) a control circuit that selectively applies power from a source of electric power to the LEDs to adjust a light output color spectrum of the one or more LEDs.

#### BRIEF DESCRIPTION OF THE DRAWINGS

FIG. 1 shows one embodiment of the present invention, a schematic representation of a handheld LED flashlight 100.

FIG. 2 is a circuit block diagram of an LED flashlight circuit 200, which circuit is used in some embodiments of LED flashlight 100 of FIG. 1 or LED light source in camcorder 500 of FIG. 5 or other devices such as machine-vision systems.



FIG. 3 a circuit block diagram of an LED flashlight circuit 300, which circuit is used in some embodiments of LED flashlight 100 of FIG. 1 or LED light source in camcorder 500 of FIG. 5 or other devices such as machine-vision systems.

FIG. 4 a circuit block diagram of an LED flashlight circuit 400, which circuit is used in some embodiments of LED flashlight 100 of FIG. 1 or LED light source in camcorder 500 of FIG. 5 or other devices such as machine-vision systems.

FIG. 5 is a diagram showing a controlled LED light source is integrated into a handheld camcorder 500.

FIG. 6 is a graph of color spectrum versus current for an LED to be used in one embodiment of the present invention.

FIG. 7 is circuit block diagram of an LED illumination device circuit 700, which circuit is used in some embodiments of LED flashlight 100 of FIG. 1 or LED light source in camcorder 500 of FIG. 5 or other devices such as machine-vision systems.

FIG. 8 is circuit block diagram of an LED illumination device circuit 700 that uses a current mirror.

FIG. 9 is a graph of color spectrum (photoluminescence) versus temperature for an LED to be used in one embodiment of the present invention.

FIG. 10 is circuit block diagram of a machine vision system using an LED illumination device according to the present invention.

FIG. 11 is circuit block diagram of an LED illumination device according to the present invention.

#### DESCRIPTION OF THE PREFERRED EMBODIMENT

In the following detailed description of the preferred embodiments, reference is made to the accompanying drawings that form a part hereof, and in which are shown by way of illustration specific embodiments in which the invention may be practiced. It is understood that other embodiments may be utilized and structural changes may be made without departing from the scope of the present invention.

The present invention takes advantage of the efficiency of high-intensity, light-emitting diodes (LEDs) in the visible spectrum and/or infra-red (IR) or ultra-violet (UV), arranged in various patterns, the low-voltage properties of CMOS integrated circuits and components, and the efficiency derived from switching the current to and limiting the duration of current to the LEDs to project light efficiently and with constant brightness even as the battery supply voltage decays over time. The invention takes advantage of the dynamic impedance of the LEDs which causes the voltage across the LED to rise rapidly relative to the current flow through the LED to limit the initial current flow to the LED, when battery voltage is highest, to prevent wire bond heating from causing premature failure of the LEDs. The present invention controls the current flow duration (pulse width) to limit power dissipation in the LEDs during the LEDs' on state, and increasing the pulse width as the battery voltage decreases over time to maintain substantially constant perceived or average LED intensity over the course of the battery's life. The invention controls the switching frequency of the pulse width to further control the LED intensity and power dissipation while maintaining a constant light output from the LEDs as perceived or visible to the human eye, or a light-sensing device, e.g., camera, night-vision scope, CMOS and CCD sensor and pixel arrays. The present invention provides a compact, portable light source,

preferably sized to be readily hand-held, for illuminating an object, several objects, or areas for human use and/or machine operation. In one embodiment, the invention measures battery voltage and in turn regulates the LED intensity. In another embodiment, the present invention uses a light-sensing device such as a light-sensing transistor or light-detecting diode (LDD) in proximity to the output LED(s) to measure the average brightness and further regulate the LEDs' output.

Another embodiment of the present invention provides operator-selectable control of the pulse frequency and/or the pulse width to provide a reduced apparent brightness in order to increase battery life in situations when maximum brightness is not required. In one such pulse-frequency embodiment, the apparent (visible) pulse frequency would provide a stroboscope effect for safety or entertainment. In this embodiment, the visibly interrupted or pulsed pulse train may include repetitive pulses or a coded sequence as in Morse code "SOS" or a predetermined password or security string of pulses that may then be used as a key or identifier. A further refinement of this embodiment would provide the user with a method for strobing out a message. It is understood that what appears to be a single visible pulse may actually include a high-frequency series of pulses in order to increase the apparent brightness of a single pulse while also protecting the LEDs from excessive power dissipation. In yet another pulse-frequency embodiment of the invention, a variable or adjustable constant sequence pulse train is established for the accurate measurement of the velocity or frequency of an object in motion or vibration.

Another embodiment of the present invention uses various colored LEDs for specialized purposes. In one such embodiment, long-wavelength LEDs, 660 nm or longer, are used to provide underwater divers or aquarium enthusiasts a light source for observing undersea life at night without adversely affecting the nocturnal activities of such wildlife. This functionality is also useful for tropical aquarium owners who also wish to observe the nocturnal activities of the occupants of their aquariums. In another such embodiment, short-wavelength blue LEDs are used with a UV filter to view fluorescing materials, including but not limited to: taggants, stamps, security codes and security seals. As UV LEDs become readily available (such as those announced as made by IBM Corporation in the Mar. 9, 1998 issue of Electronic Engineering Times, page 39), these could be used in place of the blue LEDs. In other embodiments, a suitable LED normally emitting in the blue spectrum, for example made from GaN (gallium nitride) or InGaN (indium gallium nitride), is pulsed by pulses of sufficiently high current to blue-shift the output and sufficiently short duration to not destroy the LED in order to maintain a constant light intensity while shifting the color spectrum from blue to ultraviolet. Other embodiments include IR LEDs for military or police use to enhance the usefulness of night-vision equipment and for friend-or-foe identification, multiple color LEDs to produce a white light source, and combinations of colored LEDs to enhance the ability of color-blind individuals to perceive colors. Other uses include LEDs chosen for use in photographic darkrooms wherein the LED wavelength is chosen to prevent undesired exposure of light-sensitive materials.

Another embodiment of the present invention uses LEDs of various "viewing" angles to achieve wide-angle viewing versus narrow-angle, long-range viewing and combinations thereof. A further refinement of this embodiment utilizes a Fresnel lens (or other lens or reflector arrangement) to provide a focusable light source. Another embodiment uses

polarizers to reduce specular reflections for enhanced viewing or for use in machine-vision applications. Another embodiment utilizes quickly and easily pluggable/replaceable LED arrays or heads of various shapes, colors, and/or viewing angles for different applications.

In yet another embodiment, the light output is momentarily interrupted repetitively, or strobed, to indicate low battery condition with some estimation of time to battery failure, e.g., the number of pulses could indicate the estimated number of minutes of battery time. As the estimation of time to battery failure changes, the repetition rate is varied to indicate impending battery failure. It is understood that this operational mode is easily distinguished from other operational modes by the duration of on time versus off time. In strobe mode, low battery condition is indicated by dropping pulses; e.g., every fourth output pulse is dropped, or three of four pulses is dropped creating an easily distinguishable variance in visible output of the invention.

In another embodiment of the invention, a switch is utilized to control the functions (and/or brightness) of the invention. A variance of this embodiment uses a thumb-wheel, or rotary switch to vary the switching characteristics to produce a variable light output.

In another embodiment, a programmable microprocessor is utilized to provide control functionality.

FIG. 1 shows one embodiment of the present invention (a schematic representation of a LED flashlight **100**) having a case **110**, a battery **120** or other portable DC power supply, a power supply and control circuit **130**, a switch circuit **140**, a plurality of LEDs **150**, and optionally a feedback circuit **160**.

In various embodiments of the present invention, feedback circuit **160** (and similarly the other feedback circuits described herein) controls pulse width and/or frequency as a function of parameters such as battery voltage, LED light output intensity, power dissipation or device temperature, or LED color spectrum output.

Case **110** is any convenient size and shape, and is typically designed to hold the battery, provide a suitable grip to be handheld, and provide a housing for the circuitry and LEDs. In one embodiment, battery **120** includes one or more cells which can be any suitable technology such as alkaline dry cells or rechargeable cells. Alternatively, other portable DC electrical power sources can be used as desired in place of battery **120**. Power supply and control circuit (PSCC) **130** responds to switch circuit to apply electrical power from battery **120** to LEDs **150**, controlled in order to prevent overloading and premature destruction of LEDs **150** while minimizing power dissipation with PSCC **130**, thus maximizing battery life, providing the desired accuracy or level of the amount of light emitted at different battery voltages or other environmental conditions that would otherwise vary the light output. Switch circuit **140** allows the user to control various flashlight functions such as, for example, on/off, setting light level, setting light color, setting pulse or strobe frequency, and checking battery voltage or remaining power. In one embodiment, PSCC **130** provides a pulse train, in which pulse frequency, pulse width, or pulse shape/height, and/or the number of LEDs that are driven, is controlled in order to provide a relatively constant light output level even as battery voltage declines and power is drained. In one embodiment, feedback **160** measures the light output of LEDs **150** (e.g., using a photo diode or other suitable light detecting device) and provides a signal that allows PSCC **130** to adjust the light output to a desired level (typically providing a constant light output even as battery

voltage declines as power is drained). In one such embodiment, the width of each pulse is adjusted to keep a constant average light output (widening each pulse as the intensity of light decreases, in order to obtain a constant light output). In one such embodiment, flashlight **100** is used in conjunction with a portable video camcorder or other video camera, and feedback **160** measures the overall ambient light and provides a signal that allows generation of flashlight pulses to compensate for lack of light, in order to provide optimal lighting for the video camera. In one such embodiment, the pulses to the LEDs are synchronized to the video camera frame rate using optional pulse synchronization (sync) signal **170** in order that the light pulse from LEDs **150** is only on when the video camera shutter is collecting light (avoiding light output when the camera will not benefit from it). In another embodiment, feedback **160** measures battery voltage, and increases pulse width, frequency, or height as battery voltage or power declines. In yet another embodiment, feedback **160** measures the current going through LEDs **150**, and makes the appropriate adjustment to pulse width or frequency in order to maintain constant or desired light output.

FIG. 2 is a schematic of one embodiment of a circuit used for flashlight **100**.

In this embodiment, normally open, momentary contact switch **146** is momentarily closed by a user to activate light output. Power-switch circuit **132** (in one embodiment, a TK114 circuit by Toko America available from Digikey Corporation of Thief River Falls, Minn.) is turned on as its control input **131** is shorted to ground by switch **146**, thus applying voltage to Vout, which is applied through resistor divider **138-138** to transistor **136**. In other embodiments, circuit **132** is replaced by a simple slide switch as is used in conventional flashlights, and which, when closed, connects Vin to Vout (eliminating the need for resistors **137**, **138**, and **139**, switch **146**, and transistor **136**). Transistor **136** and resistor **137** then maintain the control voltage low enough to keep power circuit **132** turned on even after switch **146** is released by the user to its open position (transistor **136** is "on" as long as circuit **132** is on and applying battery voltage to Vout). Thus power is applied to Vout until an OFF signal is set high on line **131** by microprocessor (MP) **134** (resistor **137** has a resistance that is set to a value that is small enough to keep the control pin of circuit **132** low unless overridden by the OFF signal from MP **134** going high). Microprocessor **134** is any suitable microprocessor, such as a PIC16C62X microcontroller by Microchip and available from Digikey Corp. of Thief River Falls, Minn., 56701. The PIC16C62X includes two analog comparators with a programmable on-chip voltage reference, a timer, and 13 input/output (I/O) pins each capable of direct LED driving of 25 mA source or sink. In one embodiment, MP **134** is programmed to receive a feedback signal **260** from feedback circuit **160**, and on the basis of the feedback signal, adjust the drive signal(s) **250** to LEDs **150**, thus adjusting the light output. In one such embodiment, a lookup table **234** is used to convert a digital value derived from feedback signal **260** into a digital value used to control drive signal **250**. In one embodiment, optional feature switches **142** are provided to control various parameters of light output such as, for example, intensity, color, duration (i.e., time until automatic power down), frequency-(i.e., a strobe control), etc. In one embodiment, an external pulse sync signal **170** is provided, isolated through a standard opto-isolator circuit **171**, and provided as an input to pulse sync input pin **270** of MP **134**. In one such embodiment, pulse sync signal **170** is driven from a video camera (such as a camcorder or a machine-

vision video camera), in order to synchronize light output with the light gathering/shutter open times of the camera. In another such embodiment, pulse sync signal **170** is driven from a spark-plug-wire pickup in order to provide a timing strobe of light pulses for tuning an internal combustion engine.

In one embodiment, feature switches **142** include momentary contact switches in pairs, one switch of the pair used to increase a particular parameter, and the other switch of the pair used to decrease the particular parameter (such as is done commonly in television remote control devices). In one such embodiment, a pair of switches increases/decreases overall light output intensity. In another such embodiment, color is adjusted, e.g., using one pair of buttons for blue LED output, another pair for green LED output, and a third pair for red LED output; or using one pair to control the X-coordinate and another pair to control the Y-coordinate of chromaticity (such as a CIE chromaticity diagram's X and Y coordinates). In yet another such embodiment, a pair of switch buttons increases/decreases the remaining timeout value. In one embodiment, as a feature switch is pressed to increase or decrease a parameter, the number of LEDs that are "on" are varied to provide a visual indication to the user of the value of that parameter, for example the timeout value could be varied from one to ten minutes until power off, and as the button to increase that parameter is held down, the timeout parameter is increased successively from one to ten, and a corresponding number of LEDs (one to ten) are turned on to provide this visual indication. In other embodiments, audible indications of such parameters are provided, e.g., by providing variable pitch or numbers of clicks to give the user feedback as to the value of the parameters being adjusted or measured.

A primary feature of some embodiments of the present invention is to provide a large number of individual LEDs in order to provide sufficient generalized and/or focussed illumination to be useful as a handheld flashlight, or in particular, as an illumination source for a scene or object to be imaged by a video camera (e.g., in a camcorder or machine-vision system). With current low-cost, high intensity LEDs having a luminous intensity of, say 2 cd, twenty to fifty LEDs are typically needed to provide a good flashlight, although in some applications as few as seven LEDs provide desirable results. In one such embodiment, each individual LED is separately packaged in a transparent encapsulant (e.g., a T 13/4 package) that provides manufacturing efficiencies and provides better heat dissipation by spreading the active light emitting chips apart from one another. In some embodiments, white LEDs are used (such as white LEDs that utilize a blue LED chip and a YAG phosphor that converts a portion of the blue light to yellow, thus yielding a white-appearing light output, such as part number NSPW 310AS available from Nichia Chemical Industries Ltd. of Japan and Nichia America Corp., 3775 Hempland Road, Mountville Pa., 17554). In other embodiments, standard high-efficiency colored LEDs of red, yellow, green, and/or blue are used to provide light of the desired intensity and color. In one such embodiment, LEDs of each color are controlled separately in order to provide the desired overall hue or whiteness of the combined light output.

In an application such as providing illumination for a video camera, feedback circuit **160** measures the video output signal from the camera and provides a feedback signal **260** that allows adjustment of the light output of LEDs **150** in order to optimize the video signal. In one such embodiment, as shown in FIG. 5, the controlled LED light

source is integrated into a handheld camcorder **500**. In one such embodiment, the video camera circuit also provides pulse sync signal **170** in order to synchronize the light output to the video light gathering time windows. In another such embodiment, feedback circuit **160** measures the color balance of the video output signal, and provides separate feedback intensity control for each of a plurality of (e.g., two or three) separate groups of color LEDs, for example, red, green, and blue. In one embodiment, green LEDs such as part number NSPG 500S and blue LEDs such as part number NSPB 500S, both available from Nichia Chemical Industries Ltd. of Japan and Nichia America Corp., 3775 Hempland Road, Mountville Pa., 17554 are used, and red LEDs such as part number HLMP-C115 available from Hewlett Packard Company.

FIG. 3 a circuit block diagram of an LED flashlight circuit **300**, which circuit is used in some embodiments of LED flashlight **100** of FIG. 1 or LED light source in video camera **500** of FIG. 5. Circuit **331** replaces circuit **132** and **134** of FIG. 2 using similar circuit concepts (however, in one embodiment, the entire circuitry of circuit **331** is integrated onto a single integrated circuit chip). When switch **146** is momentarily closed, circuit **331** draws output pin **332** low, turning on PNP transistor **133**, which remains turned on until circuit **331** again detects that switch **146** is momentarily closed, at which time pin **332** is allowed to float high, turning off the flashlight circuit **300**. One or more output pins **336** drive one or more low-threshold high-power MOSFETs **350** (e.g., a plurality of MOSFETs **350** are used to drive groups of LEDs of different colors, as described above). In some embodiments, pin **336** provides a variable pulse control signal to vary pulse width, pulse frequency, or both in order to control light output as described above. In the embodiment shown, output pin **333** is driven low to turn on LED **152**, and in one such embodiment, pulses LED **152** in a manner that the pulses are perceptible to the human eye, and varying the pulse pattern or timing in order to indicate the estimated remaining battery power. For example, in one embodiment, from one to ten short, individually perceptible pulses closely spaced (e.g., one-third of a second apart) pulses are driven each time the flashlight is initially turned on, that is, ten pulses closely spaced indicate that 100% of the battery power remains, 9 pulses indicate that 90% of the battery power remains, . . . and 1 pulse indicates that 10% of the battery power remains. In another such embodiment, LED **152** is repeated pulsed in this manner, e.g., ten pulses spaced at 1/3 second, then a 3 second period of time when LED **152** is off, ten pulses spaced at 1/3 second, then a 3 second period of time when LED **152** is off, in a repeating pattern as long as the flashlight is on. In one such embodiment, this provides the user with the only indication of remaining battery life, since LEDs **151** are driven to provide constant illumination, regardless of battery voltage variations or other factors that would otherwise vary light output. In other embodiments, feedback circuit **160** is omitted, and such factors do affect light output. Feedback circuit **160** is as described above, and measures light emitted by the LEDs, battery voltage, LED current, and/or other parameters in order to provide circuit **331** with information to be used to control output pin **336**, and thus light output. In one embodiment that measures light output in feedback circuit **160**, the width of the pulse needed to obtain a certain level of light output provides indirect information regarding remaining battery power, and is measured and converted into the visual indication of remaining power to be displayed by LED **152**. In another embodiment, the amount of remaining battery power is visually indicated by turning on a

proportional number of the LEDs **151** as power is initially applied, so the user, by seeing how many LEDs are lit during this initial power-indication mode, can determine the remaining battery power. Thus, by varying the number of perceptible flashes or the number of lit LEDs, or other visual indication, the remaining battery power can be conveyed to the user.

FIG. 4 is a circuit block diagram of an LED flashlight circuit **400**, which circuit is used in some embodiments of LED flashlight **100** of FIG. 1 or LED light source in video camera **500** of FIG. 5. In this circuit **400**, switch **147** applies (and removes) power to the circuit **400**. In this embodiment, circuit **433** provides a continuous series of very short pulses (e.g., 10 microseconds wide each) at a frequency much higher than the flicker rate of the human eye (e.g., between 100 Hz to 50 KHz) that drive the trigger input of circuit **434** (in this embodiment, circuits **433** and **434** are each 555-type timer circuits, or each are one-half of a 556 dual timer). Resistor **431** and constant voltage circuit **432** provide a fixed voltage to control pin **5** of circuit **555**. Since circuit **434** will operate over a wide range of voltage, as the voltage of  $V_{out}$  decreases, the constant voltage at pin **5** (from circuit **432**) will be relatively higher, thus increasing the pulse width generated by circuit **434** and output on its pin **3**. As in FIG. 3, MOSFET **350** shorts the anodes of LEDs **151** to ground for the duration that pulse from circuit **434** is high. This can provide 100 milliamps or more through each LED **151** when the battery is fully charged, but only for a very short pulse. While the 100 mA, if constant, would overload the LEDs, the short pulses are tolerated. As the battery power is drained, the voltage of  $V_{out}$  decreases, and the pulse width increases. In this way, pulse width increases as battery voltage decreases, thus compensating at least partially for the reduced peak intensity of the LEDs at lower voltage. On the other hand, LED **452** is driven directly from output pin **3** of circuit **434** though current limiting resistor **153**. LEDs **151** are "on" for proportionally longer as the pulse width increases, however, LED **452** is on proportionally shorter as pulse width increases, thus LED **452** becomes dimmer as voltage decreases, providing a visual indication of remaining battery power.

FIG. 5 is a diagram showing a controlled LED light source is integrated into a handheld camcorder **500**. In this embodiment, camcorder **500** includes lens **520**, case **510**, video circuit **570**, recorder apparatus **580**, battery **120**, control circuit **130**, feedback circuit **160**, and LEDs **150**. Typically, lens **520** forms an image of object **599** onto a CCD imaging array that is part of video circuit **570** (i.e., lens **520** and video circuit **570** form a video camera), and the corresponding video signal is recorded onto media (such as video tape or recordable digital video disk (DyD)) in recorder **580**. In other applications such as machine vision, the video signal is coupled to an image processor that in turn controls some manufacturing process, for example, and part inspection or robot arm control is accomplished. In one embodiment, feedback circuit **160** takes input from the video signal only in order to control the amount of light emitted from LEDs **150**. In other embodiments, feedback circuit **160**, instead of or in addition to input from the video signal, takes feedback input **165** from a photosensor in order to control LED light output.

FIG. 6 is a graph of color spectrum versus current for an LED to be used in one embodiment of the present invention. As is seen in the graph, as the LED current increases from 10 mA to 35 mA, the color spectrum of this exemplary LED shifts from centered at approximately 440 nanometers (blue) to centered at approximately 380 nanometers (ultraviolet),

and the overall intensity increases with increasing current. Such an LED is described by M Schauler et al, GaN based LED's with different recombination zones, MSR Internet Journal of Nitride Research, Volume 2 Article 44, Oct. 8, 1997 (internet address <http://nsr.mij.mrs.org/2/44/complete.html>). In one such embodiment, the above described pulse-width control or frequency control circuits (such as feedback circuit **160** and control circuit **134**) are used to maintain a desired illumination intensity as the color spectrum is changed by changing the current through the LED. In one such embodiment, color balance as measured by feedback circuit **160** is used to change the current of each pulse and thus the color spectrum in order to control or maintain color balance.

By controlling the amount of current (the height of each pulse), the color spectrum of the output light can be adjusted (i.e., for the above described LED, the color spectrum center wavelength is adjustable from 440 nm blue to 380 nm ultraviolet), and by simultaneously controlling pulse width and/or pulse frequency, the intensity can also be controlled (i.e., one can vary the intensity, or even keep a constant intensity as the pulse height is adjusted to change color output), e.g., by varying pulse width to provide a constant perceived or average intensity even as the color changes. FIG. 7 shows one circuit **700** to accomplish such control. The user controls the color desired via switches **140** coupled to control circuit **730**. Circuit **730** then controls the current of transistor **755** by well-known techniques such as a current mirror, and the pulse width or frequency to transistor **750** as described above (in one embodiment, a lookup table is used to choose a predetermined pulse width based on the user-selected or set color, and the current is determined by another corresponding lookup table is used to choose an appropriate current).

FIG. 8 shows another circuit **800** to accomplish such control. Feedback circuit **840** is adjusted to controls the color desired based on a detected color signal from color detector **841** in control circuit **830**. Control circuit **830** then controls the current of transistor **755** by a current mirror with transistor **754**. In addition, the pulse width or frequency to gated register **842** is optionally controlled by one or more feedback circuits **860** (which is controlled by a signal indicating supply voltage, the temperature of LEDs **151**, measured light output intensity or any other parameter over which control is desired) as described above (in one embodiment, a lookup table is used to choose a predetermined pulse width based on the user-selected or set color, and the current is determined by another corresponding lookup table is used to choose an appropriate current). In one embodiment, gated register **842** receives and stores a binary number value from feedback circuit **840**, and receives a variable-frequency and/or variable-width output-enable pulse **835** from pulse-width modulator (PWM) circuit **834**. PWM circuit **834** is driven by frequency generator **833**. In one embodiment, both PWM circuit **834** and frequency generator **833** are set to provide fixed frequency and fixed width pulses (i.e., no feedback used). In other embodiments, one or both of frequency and pulse width are variable, and in some embodiments, the variability is controlled by feedback, and in other embodiments these parameters are set-able to values chosen by a user. In some embodiments, a maximum frequency for a given pulse width, or a maximum pulse width for a given frequency is predetermined in order to prevent destruction of LEDs **151** from excessive power. In other embodiments, a temperature feedback signal indicating the temperature of LEDs **151** is coupled to feedback circuit **860** to prevent overheating of LEDs **151**. In

some embodiments, feedback circuit **860** simply inhibits and/or shortens pulses based on temperature feedback or on a predetermined maximum rate limit or pulse-width limit. FET transistors **851**, **852**, **853**, and **854**, and their respective resistors R, **2R**, **4R**, and **8R**, along with trimming resistor **859** form a controllable variable current source, which is multiplied by approximately the factor  $\beta/(\beta+2)$  by the current mirror of transistors **754** and **755** to get the sum of the current through LEDs **151**. For optimal results, transistors **754** and **755** are formed as a single integrated three-terminal device on a single substrate, in order to achieve matched betas and temperature dependence. In one such embodiment, transistor **755** is formed of multiple individual transistors wired in parallel in order to achieve higher output current (at the collector of transistor **755**) for a given input current (at the collector of transistor **754** and the bases of the two transistors). In the embodiment shown, this current mirror allows circuit **830** to determine the current through transistor **755** substantially independent of the voltage of  $V_{cc}$  and the voltage-current relationships of LEDs **151**. In the embodiment shown, LEDs **151** are wired in parallel, however, in other embodiments a single LED device is used, or a plurality of LEDs **151** are instead wired in series, or in a series-parallel arrangement as is shown in FIG. **10**.

FIG. **9** is a graph of color spectrum (photoluminescence) versus temperature for an LED to be used in one embodiment of the present invention. Such an LED is described by B. Monemar et al, Free Excitons in GaN, MSR Internet Journal of Nitride Research, Volume 1 Article 2, Jul. 8, 1996 (internet address <http://nsr.mij.mrs.org/1/2/complete.html>). In one embodiment of the present invention, a GaN or InGaN LED that exhibits a temperature-dependent color spectrum light output (i.e., electroluminescence, or light output due to a current flowing through the LED which also exhibits color-temperature dependence, as opposed to the photoluminescence graphed in FIG. **9**) has its color spectrum controlled by one of the circuits described for FIG. **1**, **2**, **3**, **4**, **5**, **7**, or **8**. In one such embodiment, feedback reduces or eliminates color changes that would otherwise occur as temperature of the LED changed. In another such embodiment, color changes are purposely induced by changing the temperature of the LED, either by heating or cooling the LED with an external temperature-change device such as a resistor, or by inducing internal temperature changes by changing the average driving current to effect a change in junction temperature in the LED. In some such embodiments, a color detector such as are well known in the art is used to provide a signal to provide feedback to control temperature.

FIG. **10** is a block diagram of the control circuit **130** for one embodiment of illumination system **100**. An Oscillator **15** (in the embodiment shown, oscillator **15** is part of an image processor as shown which is coupled to an electronic camera **14**, e.g., a charge-coupled device (CCD)), controlled by pulse-frequency circuit (such as circuit **833** of FIG. **8** or frequency generator **433** of FIG. **4**), sends a trigger signal to power supply **20**. In one embodiment, the image processor **15** generates one pulse or a plurality of pulses for each CCD frame, wherein the number of pulses generated is sufficient to provide a desired accumulation of light received by camera **14** for each frame. Within power supply **20**, the trigger signal activates pulse generator **201** to generate a control pulse of a length determined by pulse-length circuit (such as PWM circuit **834** of FIG. **8** or PWM **434** of FIG. **4**) The control pulse is used to turn on transistor Q1 to generate a flash on LEDs **25**, which is current-limited by resistor R3. The control pulse also activates the maximum-

rate-limit circuit **202**, which inhibits any further control pulses from pulse generator **201** for a predetermined amount of time. The 12 volt signal from power supply **20** is filtered by the low-pass filter comprising C1, L1, D1, and R1, and charges capacitors C2 through  $C_N$  (in one embodiment, N is **12**). In one such embodiment, C1 through C12 are each 2200  $\mu$ F, L1 is 40  $\mu$ H iron-core, D1 as a 1N4001 diode, and R1 is a 0 ohm conductor. C2 through  $C_N$  re discharged through fifteen series-wired LEDs **25**, which in this embodiment are wired in a parallel-series manner as shown, and R3 and Q1, as activated by the above-described control pulse. In one such embodiment, R3 is replaced by a zero-ohm conductor, and the voltage drop across the LEDs and Q1 is used to self-limit the current through the LEDs. The control pulse is fed across resistor R2, which in one embodiment is 100 K $\Omega$ , to develop the necessary voltage for driving transistor Q1, which in this embodiment is a MTP75N05HD MOSFET.

FIG. **11** is a more-detailed schematic diagram of power supply **20**. The input trigger is fed through resistor R2 to drive the input of opto-isolator OII. The output of opto-isolator OII is coupled through capacitor C12 (and the associated circuit R4, R6 and D2) to the TRG input of timer circuit 1C1A. (In one embodiment, timers 1C1A and 1C1B are each  $\frac{1}{2}$  of a 556-type dual timer.) The timing constant of timer 1C1A is set by C14 and R1-x, (where x is selected from 1 through N), and determines the pulse width of the control pulse driving Q1, and thus the LEDs. In one embodiment, five selectable pulse widths are predetermined and selected by SW1, which is a five-way exclusive dual-pole-single-throw switch, wherein one resistor of the set R1-1 through R1-N is selected for connection to the DIS input pin of 1C1A, and a corresponding one resistor of the set R2-1 through R2-N is selected for connection to the DIS input pin of 1C1B. The timing constant of timer 1C1B is set by C17 and R2-x, (where x is selected from 1 through N), and determines the minimum time between control pulses driving Q1, and thus the LEDs. In one embodiment, the five selectable predetermined pulse widths are 25 microseconds ( $\mu$ s), 50  $\mu$ s, 100  $\mu$ s, 200  $\mu$ s and 500  $\mu$ s; the corresponding maximum pulse rates controlled by maximum rate limit circuit **202** are 200 Hz, 120 Hz, 60 Hz, 30 Hz, and 10 Hz, respectively, and are predetermined and selected by SW1. Thus, in the embodiment which uses a 60 Hz camera image rate, 100  $\mu$ s-long control pulses are used to activate LEDs **25**. In one embodiment, it is desired to have an average LED illumination intensity of at least ten times the ambient light; thus, when imaging device **14** is taking one frame every 16.7 milliseconds, a 100 microsecond pulse should be at least 1670 times as intense as the ambient light. In one such an embodiment, a shroud is used to reduce the ambient light, and a red filter (substantially transparent to the peak wavelength of illumination source **18**) is placed over the lens of imaging device **14** in order to reduce ambient light and pass the light of illumination source **18**. The control pulse output signal is driven through resistor R3.

In one embodiment, opto-isolator OII is a 4N37-type part, resistor R2 is 100  $\Omega$ , resistor R3 is 100  $\Omega$ , resistor R7 is 1 M $\Omega$ , resistor R8 is 1K $\Omega$  and visible-color LED D3 indicates when the circuit is active, resistor R4 is 4700  $\Omega$ , resistor R5 is 10  $\Omega$ , resistor R6 is 10K  $\Omega$ , diode D2 is a 1N914, resistor R1-1 is 2.26 K $\Omega$ , resistor R1-2 is 4.53 K $\Omega$ , resistor R1-3 is 9.1 K $\Omega$ , resistor R1-4 is 18.2 K $\Omega$ , resistor R1-5 is 45.3 K $\Omega$ , resistor R2-1 is 37.4 K $\Omega$ , resistor R2-2 is 75K $\Omega$ , resistor R2-3 is 150 K $\Omega$ , resistor R2-4 is 301 K $\Omega$ , resistor R2-5 is 909 K $\Omega$ , C14 is 0.01  $\mu$ F, C17 is 0.1  $\mu$ F, C12 is 0.001  $\mu$ LF, C10 is 100  $\mu$ F, C11 is 0.1  $\mu$ F, C13, C15, and C16 are each 0.01  $\mu$ F, Q2 and Q3 are each 2N3904 NPN transistors, and RP1 is a 10 K $\Omega$  resistor pack.

## 15

It is to be understood that the above description is intended to be illustrative, and not restrictive. Many other embodiments will be apparent to those of skill in the art upon reviewing the above description. The scope of the invention should, therefore, be determined with reference to the appended claims, along with the full scope of equivalents to which such claims are entitled.

What is claimed is:

1. A portable video camera and illumination source system, comprising:

a housing;

one or more light-emitting diodes (LEDs) attached to the housing;

a video camera imaging device attached to the housing;

a control circuit that selectively applies a plurality of pulses from a source of electric power to the one or more LEDs; and

a feedback signal coupled to the control circuit, wherein the control circuit changes a characteristic of each one of the plurality of pulses to control a light output characteristic of the LEDs based on the feedback signal.

2. The system of claim 1, wherein the feedback signal is based, at least in part, on an amount of overall ambient light.

3. The system of claim 1, wherein the feedback signal changes to compensate for a change of a voltage of the source of electric power.

4. The system of claim 1, wherein the feedback signal is based on battery voltage, and the control circuit increases pulse width as battery voltage declines.

5. The system of claim 1, wherein the feedback signal is based on battery voltage, and the control circuit increases pulse frequency as battery voltage declines.

6. The system of claim 1, wherein the control circuit synchronizes pulses to a light-collection period of the imaging device in order that the light pulses from the LEDs are only on when the imaging device is collecting light.

7. The system of claim 1, wherein the feedback signal is based on a video output signal from the imaging device and the control circuit adjusts the light output characteristic in order to improve the video signal.

8. The system of claim 1, wherein the feedback signal is based on a color balance of a output signal from the imaging device and the control circuit separately adjusts the light output characteristic of each of a plurality of different color LEDs.

9. The system of claim 1, wherein the control circuit adjusts a height of a pulse to control a color spectrum of the output light and adjusts a width of the pulse frequency to control an amount of the output light.

10. The system of claim 1, wherein the control circuit adjusts a height of a pulse to control a color spectrum of the output light and adjusts a pulse frequency to control an amount of the output light.

11. A method for illuminating a scene and obtaining a video image comprising:

controlling one or more light output pulses, directed towards the scene, of one or more light-emitting diodes (LEDs);

obtaining a video image of the scene; and

generating feedback, wherein the controlling changes a characteristic of the light output pulses of the LEDs based on the feedback.

12. The method of claim 1, wherein the feedback is based, at least in part, on an amount of overall ambient light.

13. The method of claim 1, wherein the feedback changes to compensate for a change of a voltage of the source of electric power.

## 16

14. The method of claim 1, wherein the feedback is based on battery voltage, and the control circuit increases pulse width as battery voltage declines.

15. The method of claim 1, wherein the feedback is based on battery voltage, and the control circuit increases pulse frequency as battery voltage declines.

16. The method of claim 1, wherein the controlling synchronizes the pulses to a light-collection period of the obtaining the video image.

17. The method of claim 1, wherein the feedback is based on a video image and the controlling adjusts the light output characteristic in order to improve the video image.

18. The method of claim 1, wherein the feedback is based on a color balance of the video image and the controlling separately adjusts the light output characteristic of each of a plurality of different color LEDs.

19. An illumination source comprising:

a housing;

one or more light-emitting diodes (LEDs) attached to the housing;

a control circuit operatively coupled to supply electrical pulses to the one or more LEDs that adjusts a height of the pulses to control a color spectrum of the LED output light and adjusts an LED on-time proportion to control an amount of the output light.

20. The illumination source of claim 19, further comprising:

a video camera imaging device attached to the housing; wherein the control circuit adjusts pulse width in order to control the LED on-time proportion.

21. The illumination source of claim 19, further comprising:

a video camera imaging device attached to the housing, wherein the control circuit adjusts a pulse frequency in order to control the LED on-time proportion.

22. The illumination source of claim 19, wherein the control circuit adjusts a pulse width in order to control the LED on-time proportion.

23. The illumination source of claim 19, wherein the control circuit adjusts a pulse frequency in order to control the LED on-time proportion.

24. An illumination source comprising:

a housing;

one or more light-emitting diodes (LEDs) attached to the housing;

a control circuit operatively coupled to supply electrical pulses to the one or more LEDs that, corresponding to a change in a height of the pulses to the one or more LEDs, adjusts an LED on-time proportion to control an amount of output light.

25. The illumination source of claim 24, wherein the control circuit adjusts a pulse width to control the LED on-time proportion, in order to maintain a substantially constant average light output.

26. The illumination source of claim 24, wherein the control circuit adjusts a pulse frequency to control the LED on-time proportion, in order to maintain a substantially constant average light output.

27. The illumination source of claim 24, further comprising:

a video camera imaging device attached to the housing, wherein the control circuit adjusts a pulse width in order to control the LED on-time proportion.

28. The illumination source of claim 24, further comprising:

a video camera imaging device attached to the housing, wherein the control circuit adjusts a pulse frequency in order to control the LED on-time proportion.

**29.** An illumination source system, comprising:

a housing;

one or more light-emitting diodes (LEDs) attached to the housing; and

a control circuit that selectively applies a plurality of pulses from a source of electric power to the one or more LEDs;

wherein the control circuit has a feedback signal input, wherein the control circuit changes a characteristic of each one of the plurality of pulses to control a light output characteristic of the LEDs based on the feedback signal.

**30.** The system of claim **29**, wherein the feedback signal is based, at least in part, on an amount of overall ambient light.

**31.** The system of claim **29**, wherein the feedback signal changes to compensate for a change of a voltage of the source of electric power.

**32.** The system of claim **29**, wherein the feedback signal is based on battery voltage, and the control circuit increases a pulse width as a voltage of the source of electric power declines.

**33.** The system of claim **29**, wherein the feedback signal is based on battery voltage, and the control circuit increases a pulse frequency as a voltage of the source of electric power declines.

**34.** The system of claim **29**, further comprising a video camera imaging device, wherein the control circuit synchronizes pulses to a light-collection period of the imaging device in order that the light pulses from the LEDs are only on when the imaging device is collecting light.

**35.** A method for illuminating a scene comprising:

controlling one or more light output pulses, directed towards the scene, of one or more light-emitting diodes (LEDs);

obtaining a video image of the scene; and

generating feedback, wherein the controlling maintains a characteristic of the illumination on the scene by varying the pulses of the LEDs based on the feedback.

**36.** The method of claim **35**, wherein the feedback is based, at least in part, on an amount of overall ambient light.

**37.** The method of claim **35**, wherein the feedback changes to compensate for a change of a voltage of the source of electric power.

**38.** The method of claim **35**, wherein the feedback is based on battery voltage, and the control circuit increases pulse width as battery voltage declines.

**39.** The method of claim **35**, wherein the feedback is based on battery voltage, and the control circuit increases pulse frequency as battery voltage declines.

**40.** The method of claim **35**, wherein the feedback is based at least in part on a measurement of color.

\* \* \* \* \*