

In the United States Court of Federal Claims

No. 11-201C

(Filed: April 29, 2016)

ROSS-HIME DESIGNS, INC.,

Plaintiff,

v.

THE UNITED STATES,

Defendant.

*
*
*
*
*
*
*
*
*
*
*
*
*
*

Patent Infringement; 28 U.S.C. § 1498; Claim Construction; Ordinary and Customary Meaning; Prosecution History Disclaimer.

Vytas M. Rimas, Rimas Law Firm, PLLC, 5101 Thimsen Ave., Suite 204, Minnetonka, MN, 55345, for Plaintiff.

Benjamin Mizer, John Fargo, and Conrad J. DeWitte, Jr., U.S. Department of Justice, Civil Division, Commercial Litigation Branch, P.O. Box 480, Ben Franklin Station, Washington, D.C. 20044, for Defendant. Kurt G. Hammerle, Office of the Chief Counsel, NASA Johnson Space Center, Of Counsel.

CLAIM CONSTRUCTION OPINION AND ORDER

WILLIAMS, Judge.

In this action, Plaintiff, Ross-Hime Designs, Inc. (“Ross-Hime”), claims that the National Aeronautics and Space Administration (“NASA”) infringed two patents - - U.S. Patent Nos. 5,967,580 (“the ’580 Patent”) and 6,658,962 (“the ’962 Patent”) (collectively “patents-in-suit”) through NASA’s use and manufacture of the robotic hand-like manipulators in Robonaut 1 and Robonaut 2, two anthropomorphic robotics systems. This matter comes before the Court for claim construction following a technology tutorial and claim construction hearing held on May 27 through May 29, 2015, in Minneapolis, Minnesota. Following the claim construction hearing, the parties modified their proposed constructions, and briefing concluded on January 29, 2016.

Background¹

Overview of the Inventions

The inventions of the '580 and '962 Patents relate to anthropomorphic “master-slave” robotic manipulators. A “master-slave” system refers to a robotic assembly in which the robot acts as a “slave” to mimic movements performed by a human “master.” The asserted claims of the '580 Patent aim to robotically simulate a gripping mechanism. Independent Claim 1 of the '580 Patent is illustrative of its invention:

1. An articulated manipulating system for mounting on a base in a robotic manipulator and capable of engaging selected objects, and said system comprising:

a support frame having a base support for mounting on said base with said base support having a first frame extension so as to extend therefrom in a first direction and a second frame extension rotatable connected to said base support and extending therefrom in a second direction at an angle to said first direction;

a first effector base rotatably connected to said first frame extension so as to be rotatable with respect thereto in plural different directions;

a second effector base rotatable connected to said second frame extension so as to be rotatable with respect thereto in plural different directions;

first pair of base linear actuators each having an end thereof rotatably connected to said first frame extension at corresponding extension connection locations thereon, and each having that opposite end thereof rotatably connected to said first effector base at corresponding effector connection locations thereon so that any substantial differentials in movement of these actuators cause corresponding substantial motions of said first effector base towards a corresponding one of said extension connection locations and so that substantial common movements of these actuators causes substantial motions of said first said effector toward or away from both of said extension connection locations; and

a second pair of base linear actuators each having an end thereof rotatable connected to said second frame extension at corresponding extension connection locations thereon, and each having that opposite end thereof rotatably connected to said second effector base at corresponding effector connections locations thereon.

'580 Patent 27:42 - 28:9.

The hand-like manipulator of Claim 1 is depicted in Figure 11 of the '580 Patent containing “linear actuators” at 180, 181, 182, and 183:

¹ This background is derived from the record developed at the claim construction hearing. The Court has not corrected grammatical errors in quotations from the record.

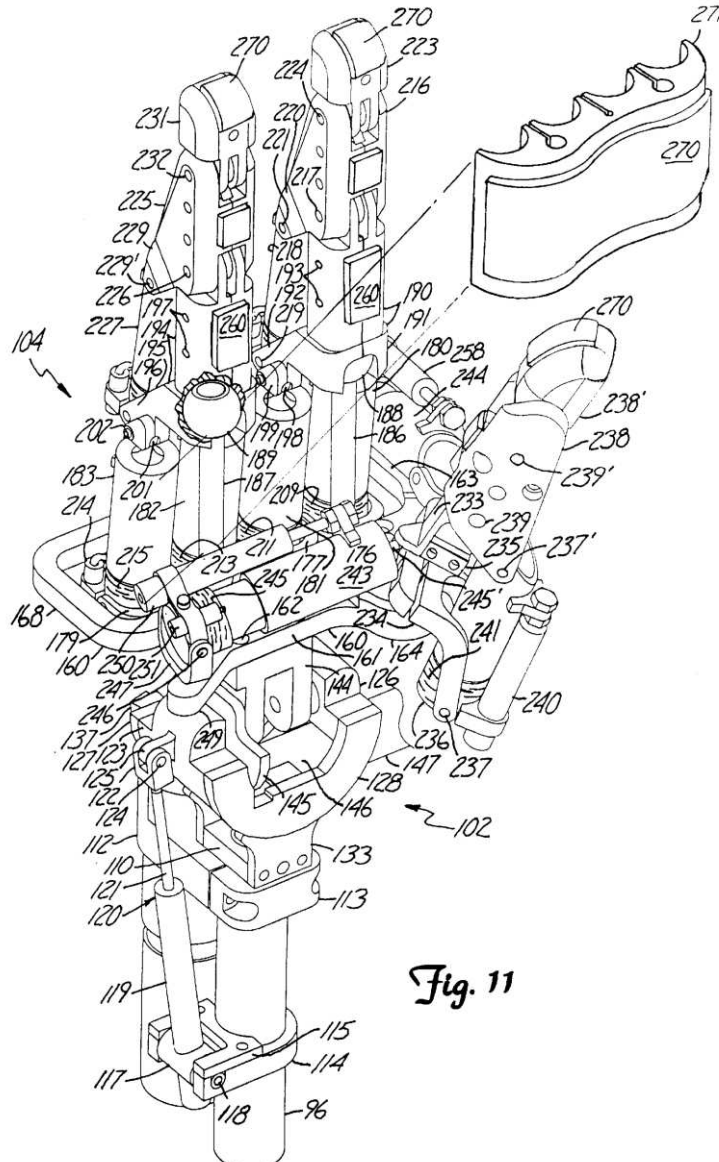

Fig. 11

'580 Patent Fig. 11.

The asserted claims of the '962 Patent also relate to hand-like manipulators "capable of engaging selected objects" '962 Patent 27:9-10. Independent Claims 11 and 14 are exemplary of the hand-like manipulators in the '962 Patent.

Claim 11 teaches:

11. An articulated manipulating system for mounting on a base in a robotic manipulator and capable of engaging selected objects, said system comprising:

a subbase rotatably mounted on said base to have a single subbase rotation axis therethrough;

a first linear actuator coupled at one end thereof to said base and coupled at an opposite end thereof to said subbase to be capable of rotating said subbase about said subbase rotation axis;

a first effector base rotatably connected to said subbase to have a first effector rotation axis

a second linear actuator coupled at one end thereof to said subbase and coupled at an opposite end thereof to said first effector base to be capable of rotating said first effector base about said first effector rotation axis.

'962 Patent 27:9-23.

Claim 14 teaches:

14. An articulated manipulating system for mounting on a base in a robotic manipulator and capable of engaging selected objects, said system comprising:

a plurality of shackles each having a pair of arms spaced apart by a recess space with said arms being joined in a joining structure on one side of said recess space;

a plurality of effector bases each rotatably mounted at a pivot location thereof to and between said separate arms of a corresponding shackle so as to leave a recess space between an end of that said effector base rotatably mounted to said shackle and said joining structure thereof;

a fixed pedestal affixed to said base and having said joining structure of a corresponding one of said plurality of shackles rotatably coupled thereto;

a moveable pedestal rotatably connected to said base and having said joining structure of a corresponding one of said plurality of shackles rotatably coupled thereto;

a pedestal linear actuator coupled at one end thereof to said base and coupled at an opposite end thereof to said moveable pedestal to be capable of rotating said moveable pedestal with respect to said base.

'962 Patent 27:56 - 28:10.

Figure 5 depicts the palm side of the hand-like manipulator of Claim 14 of the '962 Patent that contains the "shackle" system supported on a "fixed pedestal." The "shackles" are labeled as 106'A, 106'B, and 106'C in Figure 5.

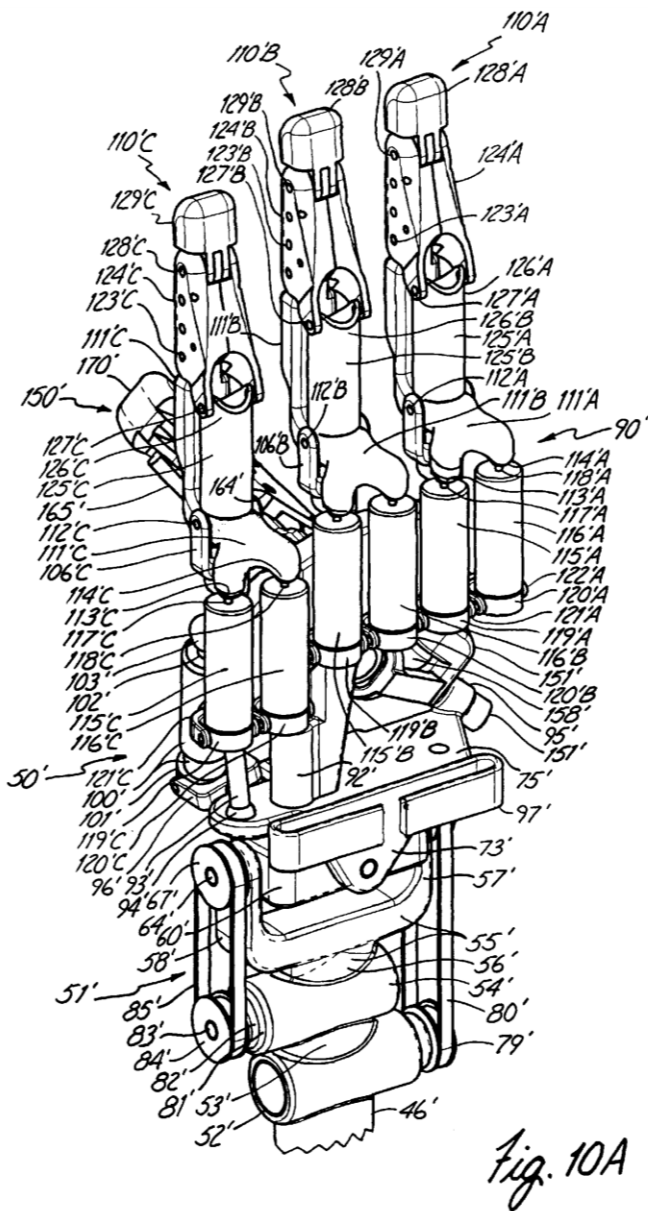

'962 Patent Fig. 10A.

Prosecution History of the '580 Patent

The '580 Patent issued on October 19, 1999, from United States Patent Application No. 08/978,192 ("the '192 Application"), filed on November 25, 1997. The '192 Application was a continuation of Application No. 08/525,395 ("the '395 Application") filed September 8, 1995, which in turn was a continuation-in-part of Application No. 08/497,199, filed June 30, 1995, both now abandoned. The '580 Patent lists Mark E. Rosheim as the inventor, and Plaintiff, Ross-Hime Designs, Incorporated, as the assignee.

On February 25, 1997, during prosecution of the '580 Patent's parent application - - the '395 Application - - Plaintiff amended Claim 1 in pertinent part, as follows:

a first pair of base linear actuators each having an end thereof rotatably connected to said first frame extension [on either side of where said first effector base is rotatably connected thereto], and each having that opposite end thereof rotatably connected to said effector base on [either side of] opposite sides thereof where said first frame extension is rotatably connected thereto so that substantial differentials in movement of these actuators causes substantial motions of said first effector base towards a corresponding one of them.²

DCX 20 at NASA-1301-02. According to the amendment, the Examiner had rejected Claim 1 of the '395 Patent as anticipated by another Ross-Hime Patent - - U.S. No. 4,821,594 (“the '594 Patent”). Id. at NASA-1305. Plaintiff explained that the linear actuators in the '395 Application were distinct from the prior art because the linear actuators in the instant invention were required to move in a “push-pull” motion for the “fingers” - - the so-called “effectors” - - to move in a side-to-side motion. In the Patentee’s own words:

The Examiner then goes on to reject claims 1 through 3, 5, 7 and 11 under 35 U.S.C. § 102 as being anticipated by U.S. Patent 4,821,594 to Rosheim et al. Apparently, the Examiner contends that the connections of the linear actuators to the driven members depicted in the ['594 reference] meet the claims of the present invention. With this contention, the applicant must respectfully disagree.

Claim 1 of the present invention requires that the linear actuators be rotatably connected to the effector base on opposite sides of where the effector base is rotatably connected to the frame extension. There is no such connection with [the '594 reference] as the rotary connections of the linear actuators are made on the bottom of the comparable effector and one side thereof, rather than on opposite sides thereof. As a result, [the '594 reference] driven members need not operate with the actuators in a push-pull mode to accomplish motions toward an actuator therein in contrast to the present invention requiring such push-pull operation for side-to-side movements of the base effector.

The applicant has amended claims 1 and 4 to make clear that opposite sides was meant where the former recitation was “on either side” and to make clear the differential movement need.

Id. at NASA-1305-06. Figure 1 of the '594 reference is depicted below and shows how individual linear actuators - - labeled as number 26 - - move individually rather than in unison as base pairs, to effect forward/backward and side-to-side motions of the robotic manipulator:

² Underlining in claim amendments depicts where new claim language is added. Deleted claim language from prior claims is bracketed.

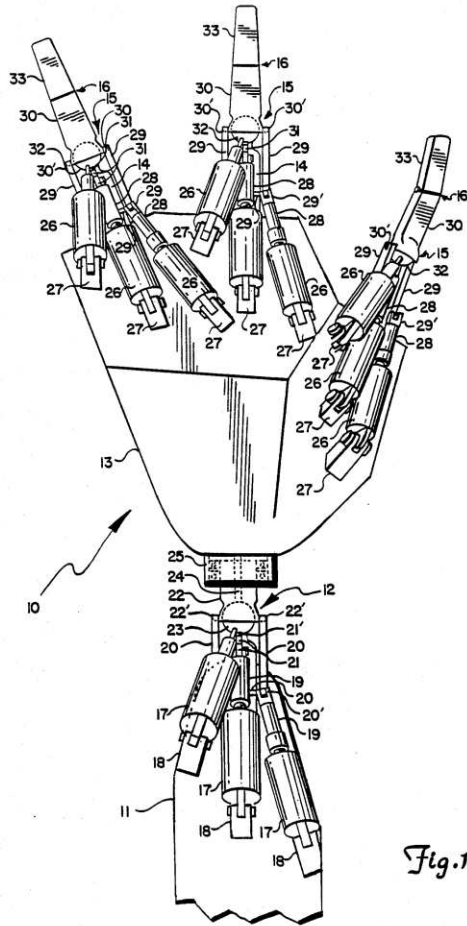

Fig. 1

DCX 05 Fig. 1.

On June 2, 1997, the Patent Examiner issued a final rejection of Claims 1-3, 5, 7, 8, 11, 13, 14, 20, and 21, and deemed Plaintiff's argument unpersuasive, "since the left most and right most actuator [both labeled as number 26] for each digit in [the '594 reference] Figure 1 are connected on opposite sides as are the actuators in figure 14." DCX 06 at NASA-1330.

On February 24, 1998, following the Examiner's rejection, Plaintiff amended Application Claim 1, stating in pertinent part:

a first pair of base linear actuators each having an end thereof rotatably connected to said first frame extension, and each having that opposite end thereof rotatably connected to said first effector base [on opposite sides thereof where said first frame extension is rotatably connected thereto] so that differentials in movement of these actuators causes substantial motions of said first effector base towards a corresponding one of them and so that substantial common movements of these actuators causes substantial motions of said first said effector toward or away from both of them.

DCX 07 at NASA-1346-47.

On April 22, 1998, the Examiner issued a final Office Action, rejecting Claims 1-3, 5, 7, 8, 11, 13, 14, 20, and 21 as anticipated by the '594 Patent under 35 U.S.C. § 102, as well as corresponding dependent claims, 4, 6, 9, 10, and 12. DCX 23 at NASA-1352.

On June 18, 1998, Plaintiff responded to the Examiner's final rejection by submitting a "Letter After Final," requesting the Examiner reconsider the final rejection of all claims. Id. at NASA-1354. Plaintiff argued:

Claim 1, however, does require that the connections of the base linear actuators recited therein to the first effector base and the first frame extension be such that substantial differentials in movements of the two actuators cause substantial motions of the effector base towards one of them, and that common movements of the two actuators results in substantial movements of the effector base toward or away from both of them. This effectively states that the first effector base cannot move in response to movement of just one of the actuators, but instead requires motion of both of the actuators if the base effector is to move at all. This statement represents that the actuators are connected to the first base effector so as to be dependent on one another, i.e. coupled to one another with respect to motion of the base effector. This arrangement in the present invention is in contrast to the devices shown in Figures 1 and 14 of the Rosheim reference where the leftmost and rightmost linear actuators can each, independently of the other, cause the digit member to which they are connected to move even if the other actuator is not acting to move that digit member. That is, the actuators in [the '594 reference] figures cited by the Examiner are connected to a digit member so as to be decoupled from one another since either one can independently drive the digit about a corresponding axis without regard to the activity of the other.

Thus, a differential motion between the leftmost and rightmost actuators connected to a digit in the Rosheim reference does not necessarily result in the digit member to which they are connected moving closer to one of those actuators. As an example, a contraction motion by a leftmost actuator, for instance, which by itself would tend to move the digit member to which it is connected toward the rear and toward that actuator, can be overridden so as to not have such a result. An accompanying, independent expansion motion of the rightmost actuator connected to that digit member can force that member away therefrom sufficiently to result instead in the digit member moving away from both of the actuators. Such a result cannot occur in the present invention because such differential motion between the actuators connected to an effector base necessarily results in that base moving closer to one of the actuators.

Thus, the rightmost and leftmost actuators in the Rosheim reference can be operated and controlled independently of one another in causing motion of the digit member to which they are connected because of being decoupled. This is certainly an advantage in simplicity of operation and in simplicity of control of such operation. On the other hand, the actuators in the present invention must be jointly controlled to obtain any usable motion of the base effector which is a disadvantage in that added complexity is required in control of those actuators to operate the base

effector. This disadvantage of being coupled is in many situations more than balanced by the advantage also obtained which is having the joint force of two actuators applied in connection with each motion of the base effector to impart thereto considerably more force than provided in the independent or decoupled actuator situation. Nothing in the Rosheim reference provides any suggestion of having the cumulative force of two actuators available to operate the digits therein.

Id. at NASA-1353-54 (emphasis added).

On July 1, 1998, the Examiner responded to Plaintiff's "Final Action Letter," affirming his earlier rejection of all claims because "claim 1 does not preclude movement of the effector base by one actuator as argued." DCX 08 at NASA-1355. The Examiner, however, decided to hold a telephonic interview with Plaintiff's counsel following this denial of reconsideration on July 16, 1998. DCX 09 at NASA-1356. The Interview Summary noted that:

Final rejection was discussed. Examiner reiterated the position in the final. Applicant's representative indicated a response would be filed.

Id.

On September 21, 1998, Plaintiff amended Application Claim 1 with respect to the linear actuators:

a first pair of base linear actuators each having an end thereof rotatably connected to said first frame extension at corresponding extension connection locations thereon, and each having that opposite end thereof rotatably connected to said first effector base at corresponding effector connection locations thereon so that any substantial differentials in movement of these actuators [causes] cause corresponding substantial motions of said first effector base towards a corresponding one of [them] said extension connection locations and so that substantial common movements of these actuators causes substantial motions of said first said effector toward or away from both of [them] said extension connection locations.

DCX 10 at NASA-1361-62. But on November 6, 1998, the Examiner again rejected the proposed claims, holding to his prior decision that Application Claims 1-3, 5, 7, 11, 20, and 21 were anticipated by the prior art '594 Patent, or otherwise rendered obvious by the '594 Patent in view of U.S. Patent No. 3,722,706 ("Blonsky") and another reference called "Walters."³ DCX 11 at NASA-1366-67. The Examiner, however, noted that Application Claims 4, 6, 9, 10, and 12 would be allowable if rewritten in independent form including all limitations of the claims on which they depend. Id. at NASA-1367.

Taking into account the Examiner's guidance, Plaintiff filed another amendment on May 6, 1999, incorporating Application Claim 4 into Claim 1. DCX 12 at NASA-1381-82. Amended Claim 1 read:

³ "Walters" is not in the Court's record.

1. (Twice Amended) An articulated manipulating system for mounting on a base in a robotic manipulator and capable of engaging selected objects, said system comprising:

a support frame having a base support for mounting on said base with said base support having a first frame extension so as to extend therefrom in a first direction and a second frame extension rotatably connected to said base support and extending therefrom in a second direction at an angle to said first direction;

a first effector base rotatably connected to said first frame extension so as to be rotatable with respect thereto in plural different directions; [and]

a second effector base rotatably connected to said second frame extension so as to be rotatable with respect thereto in plural different directions;

a first pair of base linear actuators each having an end thereof rotatably connected to said first frame extension at corresponding extension connection locations thereon, and each having that opposite end thereof rotatably connected to said first effector base at corresponding effector connection locations thereon so that any substantial differentials in movement of these actuators cause corresponding substantial motions of said first effector base towards a corresponding one of said extension connection locations and so that substantial common movements of these actuators causes substantial motions of said first said effector toward or away from both of said extension connection locations; and

a second pair of base linear actuators each having an end thereof rotatably connected to said second frame extension at corresponding extension connection locations thereon, and each having that opposite end thereof rotatably connected to said second effector base at corresponding effector connections locations thereon.

DCX 12 at NASA-1381-82.

Additionally, the Applicant amended what had been application Claim 6 to be Claim 5. The new Claim 5 read the following with respect to common and differential movements of the linear actuators:

a first pair of base linear actuators each having an end thereof rotatably connected to said first frame extension at corresponding extension connection locations thereon, and each having that opposite end thereof rotatably connected to said first effector base at corresponding effector connection locations thereon so that any substantial differentials in movement of these actuators cause corresponding substantial motions of said first effector base towards a corresponding one of said extension connection locations and so that substantial common movements of these actuators causes substantial motions of said first said effector toward or away from both of said extension connection locations.

Id. at NASA-1383. With these changes, the Examiner allowed Claims 1, 2, 3, 5-14, 20 and 21, and the '580 Patent issued on October 19, 1999. In sum, the Examiner allowed the claims with

the understanding that both linear actuators in a base pair move to effect forward/backward and side-to-side movement of the effector.

Prosecution History of the '962 Patent

The '962 Patent issued on December 9, 2003, from U.S. Patent Application No. 10/284,926 (“the '926 Application”), filed on October 31, 2002, from provisional application no. 60/336,477, filed October 31, 2001. The '962 Patent lists Mark E. Rosheim as the inventor and is assigned to Ross-Hime Designs, Incorporated.

Unlike the '580 Patent, the '962 Patent was not subject to any Examiner rejections. DCX 14 at NASA-1834. Rather, the claims were allowed within nine months of the filing date with the Examiner⁴ stating that “[n]one of the prior art of record shows or renders obvious the systems of the claims 1, 11, 14, and 20, specifically.” *Id.*⁵ The Examiner explained why, in his view, Claims 11 and 14 of the '962 Patent overcame the considered prior art references, stating:

Claim 11 requires a subbase rotatably mounted on the base to give a single subbase rotation axis, a first linear actuator coupled at one end thereof to the base and coupled at an opposite end thereof to the subbase to be capable of rotating the subbase about the subbase rotation axis; a first effector base rotatably connected to the subbase; and a second linear actuator.

Claim 14 requires a movable pedestal rotatably connected to the base and having the joining structure of a corresponding one of the plurality of shackles rotatably coupled thereto; and a pedestal linear actuator coupled at one end thereof to the base and coupled at an opposite end thereof to the movable pedestal to be capable of rotating the movable pedestal with respect to the base.

Id. Accordingly, the '962 Patent was allowed and issued on December 9, 2003.

Discussion

Jurisdiction

The Court has subject-matter jurisdiction over this action pursuant to 28 U.S.C. § 1498(a), which provides in relevant part:

Whenever an invention described in and covered by a patent of the United States is used or manufactured by or for the United States without license of the owner

⁴ The Examiner of the '962 Patent was a different person than the Examiner of the '580 Patent. Notably, the '962 Examiner only considered prior patents listing Mr. Rosheim as the inventor and did not appear to consult any other prior art references.

⁵ Although the Examiner did not elaborate on what constituted the “prior art of record,” and the Court does not have all prior art of the '962 Patent’s prosecution history in the record, the face of the '962 Patent indicates that the Examiner considered the following United States Patents, all listing Mr. Rosheim as the inventor: U.S. Patent Nos. 4,821,594, 5,692,412, 5,845,540, 5,967,580, 5,979,264, 6,105,455, and 6,418,811.

thereof or lawful right to use or manufacture the same, the owner's remedy shall be by action against the United States in the United States Court of Federal Claims for the recovery of his reasonable and entire compensation for such use and manufacture.

28 U.S.C. § 1498(a) (2012). Because NASA has made and used robotic manipulators such as the Robonaut 1 and Robonaut 2, which Plaintiff accuses infringe its '580 and '962 Patents, this Court has jurisdiction.

Stipulated Claim Terms

Following the claim construction hearing, the parties narrowed the disputed claim language. ECF No. 160. The parties agreed to the following construction of the terms below:

'580 Patent Claims	Term	Agreed Construction
5	a pair of housing sectorial frames	no construction necessary
1, 5	effector connection locations thereon	locations on the first effector base or locations on the second effector base
15	either side	plain and ordinary meaning
1, 5	Extension connection locations thereon	locations on the first frame extension or locations on the second frame extension
14	on a further common side	on a common side
1, 5	rotatable	rotatably
1, 3, 4, 5, 7, 10, 14, 15	rotatably connected and rotatable connected	plain and ordinary meaning
5	rotatably mounted	plain and ordinary meaning
1, 5	rotatably connected to said . . . frame extension so as to be	plain and ordinary meaning

	rotatable with respect thereto in plural differential directions and rotatable connected to said . . . frame extension so as to be rotatable with respect thereto in plural different directions	
4	rotatably connected to said subextension so as to be rotatable with respect thereto in orthogonal directions	plain and ordinary meaning

'962 Patent Claims	Term	Agreed Construction
14	joining structure	the structural portion joining the spaced apart shackle arms
11	rotation axis	plain and ordinary meaning
14	said base	said base in a robotic manipulator

Id.

Claim Terms at Issue

The parties identified four claims terms to be construed:

Patent Claims	Term to be Construed
'580 Patent : 1, 3, 4, 5, 8, 10, 14, 15 '962 Patent: 11, 14, 16	linear actuator
'580 Patent: 1, 5 '962 Patent: 16	differentials in movement
'580 Patent: 1, 5 '962 Patent: 16	common movements
'962 Patent: 14	shackle

Legal Standards for Claim Construction

The “bedrock principle” of patent law is that “the claims of a patent define the invention to which the patentee is entitled the right to exclude.” Phillips v. AWH Corp., 415 F.3d 1303, 1312 (Fed. Cir. 2005) (en banc) (quoting Innova/Pure Water, Inc. v. Safari Water Filtration Sys. Inc., 381 F.3d 1111, 1115 (Fed. Cir. 2004)). The meaning of claim language is often apparent on its face, but can be complicated by the human failings of the written word and the inclusion of highly technical terminology. Id. The Supreme Court recently clarified that claim construction involves a mixed question of law and fact, with a Court interpreting, as a matter of law, the intrinsic record of the patent - - the claims, specification and patent prosecution history, and interpreting as a matter of fact, the extrinsic record - - including expert testimony, analogous case law, and dictionaries. Teva Pharm. USA, Inc. v. Sandoz, Inc., 135 S.Ct. 831, 840-41 (2015) (abrogating Lighting Ballast Control LLC v. Philips Elecs. North Am. Corp., 744 F.3d 1272 (Fed. Cir. 2014) (en banc)).

Claim terms should be given their ordinary and customary meaning as used in the field of invention. Phillips, 415 F.3d at 1312-13; Vitronics Corp. v. Conceptoronic, Inc., 90 F.3d 1576, 1582 (Fed. Cir. 1996). The ordinary and customary meaning is the meaning a claim term would have to a skilled artisan at the time of invention - - the effective filing date of the patent application. Phillips, 415 F.3d at 1313 (citing Innova, 381 F.3d at 1116). A person of ordinary skill in the art is “deemed to read the claim term not only in the context of the particular claim in which the disputed term appears, but in the context of the entire patent, including the specification.” Id. “In some cases, the ordinary meaning of claim language . . . may be readily apparent even to lay judges, and claim construction in such cases involves little more than the application of widely accepted meaning of commonly understood words.” Id. at 1314. A claim can depart from its ordinary meaning only if the inventor has explicitly assigned it a separate meaning. Id. at 1316.

To construe claims, a court objectively looks at public sources, such as the patent itself, its prosecution history, or technical dictionaries available at the time, that show what a skilled artisan would have understood the disputed claim language to mean. Innova, 318 F.3d at 1116. In Phillips, the Federal Circuit clarified that courts should first review the “intrinsic” record of the patent. 415 F.3d at 1314-17. Intrinsic evidence consists of the patent claims, specification, and the patent’s prosecution history. Id. at 1314; IMS Tech., Inc. v. Haas Automation Inc., 206 F.3d 1422, 1433 (Fed. Cir. 2000). As the claims define the invention, the claim language is the most important source for a Court to consider in construing the claim terms. Phillips, 415 F.3d at 1312.

The second most critical source of intrinsic evidence is the patent specification, which “contain[s] a written description of the invention and of the manner and process of making and using it” 35 U.S.C. § 112 ¶ 1 (2006). The “specification ‘is always highly relevant to the claim construction analysis. Usually it is dispositive; it is the single best guide to the meaning of a disputed term.’” Phillips, 413 F.3d at 1315 (quoting Vitronics, 90 F.3d at 1582)). The third source of intrinsic evidence is the prosecution history, which consists of “the complete record of the proceedings before the PTO and includes the prior art cited during examination of the patent.” Id.

at 1317. The prosecution history is less useful in claim construction, however, because it can itself be ambiguous as it represents ongoing negotiations between the patent applicant and the PTO. *Id.*; see Inverness Med. Switz. GmbH v. Warner Lambert Co., 309 F.3d 1373, 1380-82 (Fed. Cir. 2002).

After consideration of the intrinsic evidence, if a court still finds the claim term to be ambiguous, it can look to extrinsic evidence which “consists of all evidence external to the patent and prosecution history, including expert and inventor testimony, dictionaries, and learned treatises.” Markman v. Westview Instruments, Inc., 52 F.3d 967, 980 (Fed. Cir. 1995). However, such external evidence is “less significant than the intrinsic record in determining the ‘legally operative meaning of claim language.’” C.R. Bard, Inc. v. U.S. Surgical Corp., 388 F.3d 858, 862 (Fed. Cir. 2004) (quoting Vanderlande Indus. Nederland BV v. Int’l Trade Comm’n, 366 F.3d 1311, 1318 (Fed. Cir. 2004)).

Person of Ordinary Skill in the Art

The parties largely agree on the definition of a person of ordinary skill in the art (“POSITA”) for the purposes of assessing the patents-in-suit. Plaintiff asserts that a POSITA would be a person with a Bachelor of Science Degree (or equivalent) in either mechanical engineering or electrical engineering with an additional “one or two years of experience in electromechanical manipulator device engineering.” Pl.’s Post-Hr’g Br. 8. Plaintiff’s expert, Mr. Theodore F. Neils,⁶ testified that “I think one of ordinary skill in the art derived from mechanical engineering courses and working with mechanical devices over the years gives you ordinary skill in many mechanical arts, including these.” Tr. 375.⁷ Defendant, relying on the testimony of its

⁶ Mr. Neils is a retired patent attorney and former practicing engineer. He holds a Bachelor of Science degree in electrical engineering from the University of Minnesota. Tr. 363; ECF No. 110 Ex. 1. Following graduation in 1963, Mr. Neils worked as an engineer at Honeywell, Inc. for eight years where he worked in “gunfire controls,” which “involved sensing and control directions, [and] control of mechanical device directions.” Tr. 363-64. Mr. Neils also worked on electrical and hydraulic motors used in military tanks that included actuators. He switched careers in 1969, and enrolled in the University of Minnesota Law School, where he received his Juris Doctor in 1972. *Id.* at 366. He continued to work in Honeywell, Inc.’s legal department until 1986, when he joined a patent law firm, Kinney & Lange, in Minneapolis, Minnesota. *Id.* at 368. The Court accepted Mr. Neils as an expert in “robotic and mechanical manipulators and technology for the time frame 1998 and 2002.” *Id.* at 391.

Mr. Neils both filed and prosecuted the patents-in-suit and is being paid on a contingent basis in this matter. Tr. 370, 379. These facts led Defendant to file a motion in limine to exclude Mr. Neils as an expert outright. The Court denied Defendant’s motion.

⁷ Plaintiff relies on Mr. Neils’ first, second, and third expert reports. Pl.’s Post Hr’g Br. 8. During supplemental briefing, the parties contested whether the Court could consider Mr. Neils’ expert reports because the reports had not been admitted as evidence during the claim construction hearing and are otherwise inadmissible hearsay under Federal Rule of Evidence (“FRE”) 801.

Here, the circumstances are unusual in that Mr. Neils’ third amended expert report was filed the night before the claim construction hearing, and Defendant did not have the opportunity

expert, Dr. Kenneth Salisbury,⁸ defined a POSITA as “someone who has a bachelor’s degree in mechanical engineering, plus two years of experience following that, and in mechanical engineering, that specifically should include some work with mechanisms.” Def.’s Post-Hr’g Br. 6; Tr. 462.

The Court adopts the parties’ substantively similar definitions of a POSITA to be someone with a Bachelor’s degree, or equivalent, in mechanical engineering with a minimum of two years of experience following graduation, including work with mechanisms. Tr. 375, 462.

The parties also agree on the effective filing date of the patents for the purposes of claim construction - - November, 25, 1997, for the ’580 Patent and 2002 for the ’962 Patent. Def.’s Post-Hr’g Br. 6; Pl.’s Post-Hr’g Br. 8, 23.

Claim Construction

Plaintiff asserts that NASA infringes independent Claims 1 and 5 of the ’580 Patent, and dependent Claims 3, 4, 7, 8, 10, 14, and 15, all of which depend on Claim 1. Independent Claim 1 is substantially similar to Independent Claim 5 for claim construction purposes. Plaintiff further alleges that NASA infringes independent Claims 11 and 14 of the ’962 Patent, as well as Claim 16 that depends on Claim 14. As the parties propose the same construction for the same three disputed terms found in both the ’580 and ’962 Patents - - “linear actuator,” “differentials in movement,” and “common movements” - - and both patents list Mr. Rosheim as the inventor, the Court applies the same construction to each common term for both patents. Cf. Laryngeal Mask Co. Ltd. v. Ambu, 618 F.3d 1367, 1373 (Fed. Cir. 2010) (recognizing that the same term appearing

to review Mr. Neils’ third amended expert report before the hearing. Tr. 584. The Court therefore allowed Plaintiff to use Mr. Neils’ second amended expert report as a roadmap during the Claim Construction hearing to facilitate Mr. Neils’ testimony. Tr. 655. The Court will thus only consider the content from Mr. Neils’ second amended expert report referenced during the hearing. To the extent that Plaintiff cites information from Mr. Neils’ second or third amended expert report that was not referenced at this hearing, that information is inadmissible hearsay under FRE 801. Bianco v. Globus Med. Inc., 30 F. Supp. 3d 565, 570 (E.D. Tex. 2014) (citing Engebresten v. Fairchild Aircraft Corp., 21 F.3d 721, 729 (6th Cir. 1994); Mahnke v. Wash. Metro. Area Transit Auth., 821 F.Supp. 2d 125, 154 (D.D.C. 2011); Skyline Potato Co. v. Hi-Land Potato Co., 2013 WL 311846, at *15 (D.N.M. Jan. 18, 2013)).

⁸ Dr. Salisbury is a Professor at Stanford University’s Department of Computer Science & Surgery in the Schools of Engineering and Medicine. Tr. 169-70; DCX 18. He holds a Bachelor of Science degree in electrical engineering and a Master of Science degree and Ph.D. in mechanical engineering from Stanford University. Tr. at 166. Dr. Salisbury has worked as a research and development engineer, and a technical advisor for approximately 40 years at companies including Hewlett-Packard, APD, SRI International, and at the NASA/Ames Research Center and the Robotic Ventures Fund. DCX 18. He also was the President and founder of his own company, Salisbury Robotics, Inc., where he designed and sold robotic hands. Tr. 168. Dr. Salisbury has an extensive consulting record, is a named inventor in 35 United States Patents and Patent Applications, and has co-authored five books on robotics and 34 papers on various electrical and mechanical engineering topics. DCX 18. The Court accepted Dr. Salisbury as an expert in the construction of robotic manipulators and hands. Tr. 174.

in two prior art patents listing the same inventor should be construed the same way). The fourth disputed term, “shackle,” only appears in the ’962 patent.

“Linear Actuator”

The parties propose the following constructions of “linear actuator” for both the ’580 and ’962 Patents:

Term	Plaintiff’s Proposed Construction	Defendant’s Proposed Construction
“linear actuator”	a device with an output structure selectively forced into motion by a motor and connectable to allow forcing, and following the motion of that to which it is connected.	a device, with ends defined by a base piece and an extending piece, that converts some kind of power into bi-directional linear motion relative to the base piece and the extending piece, the device being able to connect rotatably at its ends to other components of a larger structure.

Plaintiff argues that the term “linear actuator” should be broadly construed to include the arcing movements of the extending piece of the actuator, the so-called “output structure,” based upon movements of structures rotatably connected to the actuator. Pl.’s Post-Hr’g Br. 9 (“Plaintiff’s construction of linear actuator covers the possible movements of the output structure of the linear actuator with respect to the hand thereof and the corresponding movements of the members of the rotational joint to which it is rotatably connected.”) (second emphasis added). Plaintiff also argues that the ’580 Patent “teaches different kinds of linear actuators, including garden variety linear actuators and garden variety linear actuators converted to special linear actuators.” Pl.’s Post-Hr’g Br. 13.

Defendant argues that “linear actuator” should be construed solely to refer to the movement of the extending piece of the actuator relative to the actuator’s base piece, and not expansively to include the resulting movement of structures rotatably connected to the linear actuator’s ends. Def.’s Post-Hr’g Br. 7-8.

As such, the issues before the Court are whether the ’580 and ’962 Patents limit the meaning of “linear actuator” to linear back-and-forth motion of the actuator alone, or broadly include circular motions of structures rotatably connected to the linear actuators. Also at issue is whether the term “linear actuator” is meant to encompass what Plaintiff calls “converted end linear actuators.” Pl.’s Post-Hr’g Br. 16-17.

Ordinary and Customary Meaning

The parties do not dispute the term “actuator” itself, both recognizing an actuator is a device that converts power into motion. Pl.’s Post-Hr’g Br. 9 (proposing an actuator to be “a device with an output structure selectively forced into motion by a motor”); Def.’s Post-Hr’g Br. 7 (proposing that an actuator be a device that converts some kind of power into motion).

The parties also appear to agree that linear means in a straight line. Plaintiff states that “[r]elative to its base, the linear actuator manipulable member will move in a straight line” and “the controlled movable output structure end of a linear actuator assembled in the hand moves in a straight line only relative to the base structure of the linear actuator.” Pl.’s Post-Hr’g Br. 12, 26 (emphasis added). Defendant agrees that the linear actuator “converts some kind of power into bi-directional linear motion relative to the base piece and the extending piece,” and that “the linear actuator, in fact, only produces linear motion.” Def.’s Post-Hr’g Br. 7, 11 (emphasis added).

The Court too recognizes that according to its ordinary and customary meaning, “linear” is an adjective meaning “in a straight line” - - not a curved line. See Phillips, 415 F.3d at 1314 (noting that “[i]n some cases, the ordinary meaning of claim language as understood by a person of skill in the art may be readily apparent even to lay judges” and that claim construction may involve “little more than the application of the widely accepted meaning of commonly understood words.”

However, Plaintiff strays from the widely accepted meaning of “linear” asking the Court to add a gloss contradictory to the straight-line notion that “linear” implies. Plaintiff posits that linear actuator here should be construed to encompass a partially circular or arc-like movement, arguing that when the manipulator member is extended, the structures attached to the linear actuator’s rotatable connections cause the actuator ends’ “path in space” to move in an arc. Pl.’s Post-Hr’g Br. 12. Hence Plaintiff asks the Court to characterize the linear actuator to encompass the structures rotatably connected to the linear actuator. Id. In so arguing, Plaintiff attempts to include in the definition of linear actuator the movement of a wholly different structure - - the member of the rotational joint to which the linear actuator is rotatably connected.⁹ This broadening of the term is unwarranted by the term’s language in the context of the claim. Plaintiff further urges the Court to construe this term to encompass linear actuators that have additional features attached to its ends - - such as flexible tape - - that Plaintiff calls “converted end linear actuators” or “special linear actuators.” Pl.’s Post-Hr’g Br. 11-12.

Defendant agrees that the linear actuator’s ends are capable of moving in arcs in three-dimensional space but disputes that the construction of “linear actuator” should encompass the movement of other structures rotatably connected to the actuator. Def.’s Post-Hr’g Br. 8

⁹ Plaintiff’s original proposed construction for “linear actuator” was an “output structure selectively forced into motion by a motor to follow a curved or straight line path.” Following the Markman hearing, Plaintiff removed the term “curved” from its proposed construction and instead expressly recognized that the linear actuator itself only moves in a “straight line.” Pl.’s Post-Hr’g Br. 12 (“Relative to its base, the linear actuator manipulable member will move in a straight line . . .”). Now, Plaintiff has walked back its construction adding within the meaning of linear actuator itself, that the structures rotatably connected to the linear actuator’s ends are capable of arcing movements.

("[D]efendant's revised claim construction describes the function of the linear actuator as a bi-directional linear motion generator, and also describes the possibility for structure that Plaintiff argued during claim construction was necessary to allow for the linear actuator being rotatably connected at both ends to other structures.").

Because the extending piece of the linear actuator only moves back and forth in a straight line relative to the base piece, but the rotational connections allow the actuator to twist and turn, causing circular movements in space, the Court is inclined to adopt Defendant's plain-meaning construction. When the plain meaning of a claim is immediately apparent, the Court should refrain from "elaborate interpretation." See Brown v. 3M, 265 F.3d 1349, 1352 (Fed. Cir. 2001). Thus, in the Court's view, the plain meaning construction of "linear actuator" would be:

a device, with ends defined by a base piece and an extending piece, that converts some kind of power into linear motion such that the extending piece moves in a straight line relative to the base piece.

However, given Plaintiff's arguments here, it is appropriate for the Court to look to the patent and prosecution history to determine whether Plaintiff can show any convincing reason for the Court to depart from the ordinary and customary meaning of linear actuator. See DSW, Inc. v. Shoe Pavilion, Inc., 537 F.3d 1342, 1347 (Fed. Cir. 2008) ("[A]bsent contravening evidence from the specification or prosecution history, plain and unambiguous claim language controls the construction analysis.").

The Claim Language Does Not Expand the Construction of Linear Actuator Beyond its Ordinary and Customary Meaning

Claim 1 of the '580 Patent states the following with respect to the structure of linear actuators:

first pair of base linear actuators each having an end thereof rotatably connected to said first frame extension at corresponding extension locations thereon . . . ;

a second pair of base linear actuators each having an end thereof rotatable connected to said second frame extension at corresponding extension locations thereon

'580 Patent 27:57 - 28:7. The '580 Patent only includes language to suggest that structures "rotatably connected" to the ends of the linear actuator are capable of rotating around the end of the linear actuator. Thus there is no need for the Court to add additional structural features to the claimed linear actuators themselves. The claims do not include any language to suggest that the linear actuators extend or retract in any direction except in a straight line. Indeed, were the Court to add language in its construction to include circular movement of the structures rotatably attached to the actuator, the "rotatably connected" language of Claim 1 of the '580 Patent and Claim and the "capable of rotating" language of Claim 14 of the '962 Patent would be redundant.

The '962 Patent Claim 11 similarly expresses the structure of the linear actuator as:

a subbase rotatably mounted on said base to have a single subbase rotation axis therethrough;

a first linear actuator coupled at one end thereof to said base and coupled at an opposite end thereof to said subbase to be capable of rotating subbase about said subbase rotation axis.

'962 Patent 27:12-17, 20-24 (same for second linear actuator). According to Claim 11, the subbase in the '962 Patent rotates around the "subbase rotation axis," with the subbase coupled to one end of the linear actuator - - with the linear actuator being a distinct stand-alone structure. As such, the Court declines to import external structures, such as the "rotatably mounted" subbase, into its construction of linear actuator.

Further, the claims do not support finding that the term "linear actuator" should encompass separate structures attached to the linear actuator ends, what Plaintiff calls "converted end linear actuators" or "specialized linear actuators." By "converted end linear actuator," Plaintiff means a linear actuator that has an additional structure attached, such as the flexible tape 82 in Figure 10 of the '580 Patent. Pl.'s Post-Hr'g Br. 12. Figure 10 is depicted below:

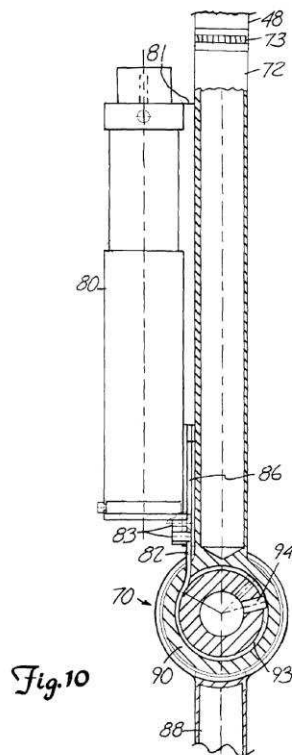

Plaintiff's position is undercut by Figure 10 itself. The linear actuator in Figure 10 is depicted as structure 80, and the flexible tape is considered a separate structure 82. Accordingly, what Plaintiff calls a "converted end linear actuator" is comprised of two separate structures - - the actuator and the tape, not one integrated structure. See '580 Patent 10:32-36 ("Thus, movement of linear actuator **80** in FIG. 10, thereby forcing upward the end of the tape **82** connected to it, will lead to clockwise motion of joint extension **88**, and downward motion of linear actuator **80** will lead to counterclockwise motion of joint extension **88**."). The linear actuator of Figure 10 is only

capable of linear motion - - straight upward and downward, while the flexible tape is a separate structure capable of curved motion.¹⁰

Although Plaintiff attempts to shoehorn these additional structures into the category of linear actuators by labeling them “specialized linear actuators,” these structures are distinct. When additional structures are to be affixed to the ends of the linear actuators, the claims explicitly say so. For example, Claim 14 of the ’962 Patent incorporates the modifier “pedestal” to “linear actuator” such that the term reads a “pedestal linear actuator.” Claim 14 reads in relevant part:

a pedestal linear actuator coupled at one end thereof to said base and coupled at an opposite end thereof to said moveable pedestal to be capable of rotating said movable pedestal with respect to said base.

’962 Patent 28:7-10 (emphasis added). Because the Claim adds the modifier “pedestal” to “linear actuator,” a POSITA would understand that the ’962 Patent would expressly delineate in the claims between a “linear actuator” and a modified linear actuator. See Pl.’s Post-Hr’g Br. 13. A POSITA would understand that if the patentee meant anything but a typical linear actuator it would have added a modifier - - such as “pedestal,” and he did not do so here. Accordingly, the Court will not construe linear actuator in an overly broad manner to include connected structures.

Specification

Like the claim language, the ’580 and ’962 specifications demonstrate that a linear actuator is only capable of moving in a linear motion - - i.e., in a straight line - - but has ends capable of rotatably connecting to additional structures. For example, in the “yoke” end of the extending piece 264 of the actuator, number 265 in Figure 15 below, the holes enable the actuator to be rotatably connected to a structure, so the connected structure is capable of rotating around that end:

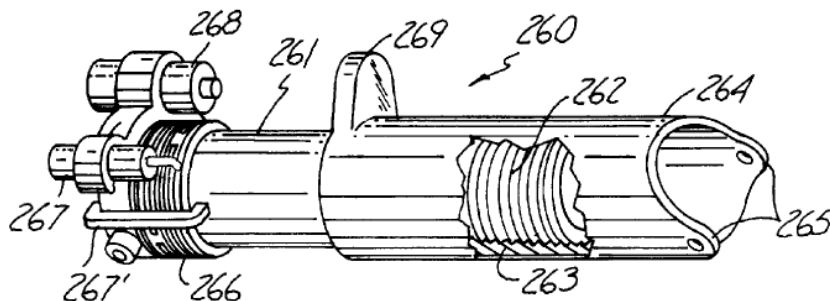

Fig. 15

’580 Patent Fig. 15.

Figure 15 of the ’580 Patent is illustrative of all linear actuators used in the ’580 Patent. ’580 Patent 18:32-34. It depicts a rigid structure with a base piece 261 and an extending piece 264, with the extending piece 264 only capable of moving back-and-forth linearly along interior

¹⁰ Plaintiff additionally fails to clarify what a “specialized linear actuator” means as compared to an unmodified “linear actuator,” stating “garden variety linear actuators” are converted to “special linear actuators.” Pl.’s Post-Hr’g Br. 13.

screw thread arrangement 263. *Id.* at 18:34-40. As such, the extending piece only moves in a straight line relative to the base piece.

Similarly, Figure 12 depicts the back of the robotic “hand” in which three linear actuators can be seen connecting to each of two “fingers” of the ’580 Patent. Figure 12 illustrates the construction of a “linear actuator” (number 227) on the back of the farthest right “finger” of the following drawing:

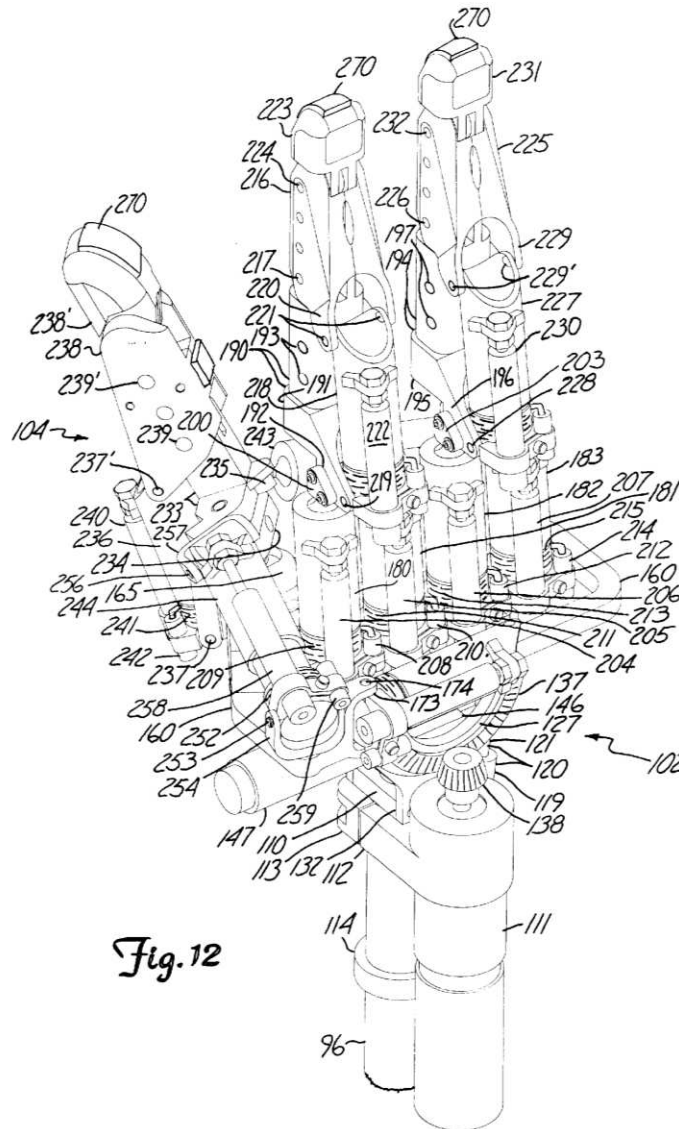

Fig. 12

'580 Patent Fig. 12.

Two of the three linear actuators - - 182 and 183 - - connect to the lower portions of the “finger” farthest from the thumb and replicate the movement of the lower segment of the “finger” - - the “effector base.” The third linear actuator, 227, sits above the two linear actuators, 182 and

183, and controls the upper portion of the “finger” described in the ’580 Patent as the “first gripping extension.” The specification describes linear actuator 227, controlling the “first gripping extension” in Figure 12, as:

A linear actuator, **227**, has a base end thereof rotatably connected by a pivot pin, **228**, between the extensions of yoke **196**. The moveable end of actuator **227** is rotatably connected between a pair of extensions forming a yoke, **229**, in first gripping extension **225** by a pair of pivot pins **229'**. Extensions and retractions of linear actuator **227** forces gripping extension **225** to rotate forward and backward about pins **229'** with respect to effector base **194**.

’580 Patent 17:7-14 (emphasis added). In other words, the moveable end of the linear actuator extends and retracts in a straight line relative to the base piece.

Figure 14 depicts the linear actuator representative of the ’962 Patent, which also has a yoke at the end of the extending piece 132:

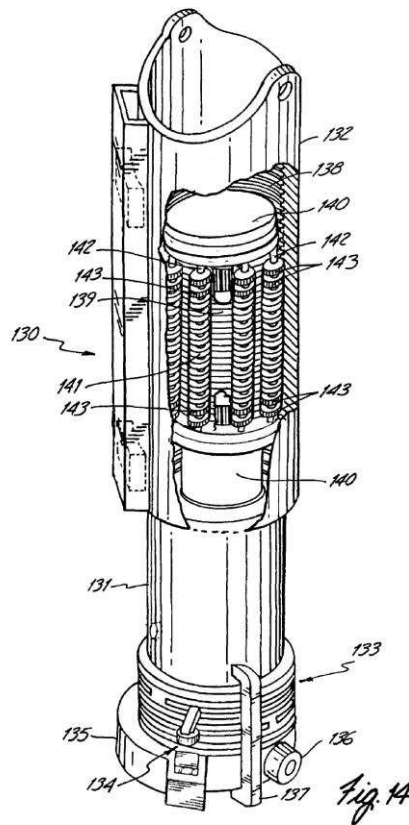

The ’962 Patent specification describes the linear actuator in Figure 14:

FIG **14** shows a perspective view of a linear actuator, **130**, of the kind used in both joint and manipulator structure **50** and joint and manipulator structure **50'** in FIGS. **5, 10A, 11, 12** and **13** [the robotic hand-like figures]. Actuator **130** has a base, **131**, more or less radially symmetric about a long axis of actuator **130** in the form approximately of a truncated cylindrical shell, and an outer body, **132**, partially

thereabout also in the form approximately of a truncated cylindrical shell more or less radially symmetric about the actuator long axis but of a larger interior diameter than the outer diameter of the base **131**. (Alternatively, outer body can additionally have an output shaft centered about the actuator long axis thereon, and affixed to, the end thereof rather than the openings across from one another at the end thereof as shown.) Base **131** has an unseen electric motor provided in its shell, and outer body **132** is driven by this motor to linearly extend or retract under the direction of the unseen control system, connected to the motor by unseen wiring, which determines when current is to be supplied to this motor to cause rotation in one direction or the other of its rotor.

Base **131** has a force sensor, **133**, formed of a multiple slitted side truncated cylindrical resulting in partially separated rings that effectively become a spring that can be expanded or compressed by axial forces on actuator **130** that can be measured by measuring the resulting distances of expansion or compression.

'962 Patent 18:3-28 (emphasis added).

Like the '580 Patent, the '962 Patent specification describes the linear actuator as having a base piece containing an internal motor that drives the movable extending piece to linearly extend and retract relative to the base piece. A POSITA would thus understand the linear actuators in the patents-in-suit to have the extending piece moving in a straight line relative to the base piece.

The Prosecution History Does Not Alter the Ordinary and Customary Meaning of Linear Actuator

The prosecution history similarly supports applying the ordinary and customary meaning of "linear" meaning in a straight line. As discussed above, in distinguishing the linear actuators used in the '580 Patent from the prior art - - the '594 reference that contained a hand with rotatable actuators - - the Applicant stated:

Claim 1 of the present invention requires that the linear actuators be rotatably connected to the effector base on opposite sides of where the effector base is rotatably connected to the frame extension. There is no such connection with [the '594 reference] as the rotary connections of the linear actuators are made on the bottom of the comparable effector and one side thereof, rather than on opposite sides thereof. As a result, [the '594 reference] driven members need not operate with the actuators in a push-pull mode to accomplish motions toward an actuator therein in contrast to the present invention requiring such push-pull operation for side-to-side movements of the base effector.

DCX 20 at NASA-1305-06. The Applicant similarly described the linear actuators as only functional in the '580 Patent when they operate in a push-pull mode. This would indicate to a POSITA that the linear actuator would move back and forth - - pushing and pulling - - in a straight line to effect movement of the "base effector." A POSITA would therefore understand that a linear actuator should be defined based on the straight-line movement of the extending piece relative to the base piece.

The Court’s Construction of “Linear Actuator”

Because Defendant’s construction comports with the ordinary and customary meaning of the term “linear actuator,” and Plaintiff has not shown why the Court should depart from that plain meaning, the Court largely adopts Defendant’s construction. The Court thus construes the term “linear actuator,” as it would be understood by a POSITA, to mean “a device, with ends defined by a base piece and an extending piece, that converts some kind of power into linear motion such that the extending piece moves in a straight line relative to the base piece.”

In so construing “linear actuator,” the Court recognizes that these linear actuators are able to move in arcs in three-dimensional space. The capability of the linear actuator to turn in arcing movements in space, however, is expressed in the claims by the rotatable connections on either end of the linear actuator not the linear actuator itself. To define linear actuator to itself possess the feature of rotational movement would be redundant. In addition, the Court does not construe “linear actuator” to include an amorphous notion of “specialized” or “converted end” linear actuators because these “specialized” features are also separate structures, such as the flexible tape in Figure 10 of the ’580 Patent attached to the linear actuator ends. Moreover, the claims already express when modifications are required, such as the “pedestal linear actuator” in Claim 14 of the ’962 Patent, so it would be inappropriate to add Plaintiff’s suggested modifier, “converted end,” to expand the meaning of linear actuator.

“Differentials in Movement”

The parties propose the following constructions for “differentials in movement”:

Term	Plaintiff’s Proposed Construction	Defendant’s Proposed Construction
“differentials in movement”	differences in movement	synchronized movement of two linear actuators in opposite directions

The parties agree that the “differentials in movement” of the linear actuators cause the individual “fingers” of the robotic hand-like manipulator to wag in a side-to-side fashion at the “knuckle” joint located at the bottom of the finger-like “effector base.” Pl.’s Post-Hr’g Br. 18; Def.’s Post-Hr’g Br. 21. The parties dispute whether “differentials in movement” would be understood by a POSITA to mean that only one of the linear actuators in the base pair extends and retracts individually for the “finger” to move in a side-to-side manner. Plaintiff’s position is that only one actuator needs to extend and retract to cause side-to-side movement. Defendant counters that both base pair linear actuators must move to effect side-to-side movement based on the Applicant’s statements to that effect during prosecution history.

The doctrine of prosecution disclaimer governs the construction here. The Applicant made a clear and unmistakable disclaimer during prosecution history that both base linear actuators forming the base pair must move for the effector - - the finger of the hand - - to move at all. See Purdue Pharma L.P. v. Endo Pharm., Inc., 438 F.3d 1123, 1136 (Fed. Cir. 2006) (“Under the doctrine of prosecution disclaimer, a patentee may limit the meaning of a claim term by making a clear and unmistakable disavowal of scope during prosecution . . . for example, when the patentee explicitly characterizes an aspect of his invention in a specific manner to overcome prior art.”).

Prosecution History Disclaimer

During prosecution, the Applicant articulated how the base pair of linear actuators effected movement of the “effector bases” to overcome an Examiner rejection. The Applicant amended Claim 1 of the ’580 Patent’s application on February 24, 1998, stating:

a first pair of base linear actuators each having an end thereof rotatably connected to said first frame extension, and each having that opposite end thereof rotatably connected to said first effector base [on opposite sides thereof where said first frame extension is rotatably connected thereto] so that substantial differentials in movement of these actuators causes substantial motions of said first effector base towards a corresponding one of them and so that substantial common movements of these actuators causes substantial motions of said first said effector toward or away from both of them.

DCX 07 at NASA-1346-47.

On April 22, 1998, the PTO issued a final Office Action, rejecting Claim 1. DCX 23 at NASA-1352. On June 18, 1998, the Applicant responded to this rejection by submitting a “Letter After Final,” requesting the Examiner reconsider its final rejection of all claims. Id. at NASA-1354. The Applicant argued that the ’580 Patent’s application overcame the prior art, stating:

Claim 1, however, does require that the connections of the base linear actuators recited therein to the first effector base and the first frame extension be such that substantial differentials in movements of the two actuators cause substantial motions of the effector base towards one of them, and that common movements of the two actuators results in substantial movements of the effector base toward or away from both of them. This effectively states that the first effector base cannot move in response to movement of just one of the actuators, but instead requires motion of both of the actuators if the base effector is to move at all. This statement represents that the actuators are connected to the first base effector so as to be dependent on one another, i.e., coupled to one another with respect to motion of the base effector. This arrangement in the present invention is in contrast to the devices shown in Figures 1 and 14 of the Rosheim reference [the ’594 Patent pictured above] where the leftmost and rightmost linear actuators can each, independently of the other, cause the digit member to which they are connected to move even if the other actuator is not acting to move that digit member. That is, the actuators in [the ’594 Patent] figures cited by the Examiner are connected to a digit member so as to be decoupled from one another since either one can independently drive the digit about a corresponding axis without regard to the activity of the other.

* * *

On the other hand, the actuators in the present invention must be jointly controlled to obtain any usable motion of the base effector which is a disadvantage in that added complexity is required in control of those actuators to operate the base effector. This disadvantage of being coupled is in many situations more than balanced by the advantage also obtained which is having the joint force of two

actuators applied in connection with each motion of the base effector to impart thereto considerably more force than provided in the independent or decoupled actuator situation. Nothing in the Rosheim reference provides any suggestion of having the cumulative force of two actuators available to operate the digits therein.

Id. at NASA-1353-54 (emphasis added).

The Applicant’s statement that “the first effector base cannot move in response to movement of just one of the actuators, but instead requires motion of both of the actuators if the base effector is to move at all” and that the actuators “must be jointly controlled to obtain any useable motion of the base effector” is a clear and unmistakable disavowal of the scope of Claim 1, removing from the invention the notion that just one actuator can move the base effector side-to-side. See Golden Bridge Tech., Inc. v. Apple Inc., 758 F.3d 1362, 1365 (Fed. Cir. 2014) (citing Omega Eng’g, Inc. v. Raytek Corp., 334 F.3d 1314, 1325-26 (Fed. Cir. 2003)); see also Am. Innotek, Inc. v. United States, No. 11-223C, 2016 WL 1454661, at *10 (Fed. Cl. Apr. 12, 2016). The statement was made in an effort to overcome the ’594 Patent prior art, and unequivocally limits Claim 1 such that “the movement of just one of the actuators” cannot move the effector base on its own, “but instead requires the motion of both the actuators if the base effector is to move at all.” DCX 23 at NASA-1353. As such, the Court finds that both linear actuators in the base pair must move for the effector base to wag side-to-side.

The Court further finds that the language the Applicant used in the disclaimer unequivocally connotes synchronized movements of the base pair of linear actuators. The Applicant’s statements that “the actuators are connected to the first base effector so as to be dependent on one another, i.e., coupled to one another with respect to motion of the base effector” and that the base pair of linear actuators “must be jointly controlled to obtain any usable motion of the base effector” necessitate synchronicity of movement of the base pair to effect any movement of the base effector. DCX 23 at 1353-54 (emphasis added). A POSITA would thus understand that the base pair of linear actuators must extend and retract in a synchronized fashion for the base effector to move.

Plaintiff’s expert, Mr. Neils, attempted to relegate this disclaimer to the status of a mere scrivener’s error, stating that the Letter After Final is “quirky” and “[l]ooks like it has a couple of words dropped.” Tr. 674. Mr. Neils did not explain how he came to that conclusion. Indeed, during the claim construction hearing, Mr. Neils reviewed the “Letter After Final” quoted above and testified as follows on cross examination:

MR. NEILS: I’m sorry. Okay. Dr. Salisbury is right.¹¹ There is a quirky sentence in there. Looks like it has a couple of words dropped.

THE COURT: It looks like it has a couple of words – I didn’t hear you.

¹¹ Dr. Salisbury testified that the sentence in the Letter After Final, stating that the first effector base “cannot move in response to movement of just one of the actuators, but instead requires motion of both actuators,” was “strange” because it limited the operation of the robotic hand to “a subset of the potential of all operations” Tr. 632-34.

MR. NEILS: Dr. Salisbury pointed out that the sentence was kind of quirky. I think a couple of words were dropped somehow when this was composed and sent in to the patent office.

QUESTION: So Mr. Neils, is that your expert opinion or your opinion as the patent attorney who prosecuted this application?

MR. NEILS: Well, the sentence is quirky.

Id. Mr. Neils further testified it “appear[ed] [the statement] would have been in response” to the office action summary that rejected the ’580 Patent claims over the prior art. Id. at 675.

The Court recognizes that disavowal would not apply when a “person of reasonable intelligence would not be misled into relying on the erroneous statement.” See Biotec Biologische Naturverpackungen GmbH & Co. v. Biocorp, Inc., 249 F.3d 1341, 1348 (Fed. Cir. 2001). Here, however, the statement does not appear to be erroneous. Rather, the Applicant’s statement that Claim 1 “requires motion of both of the actuators if the base effector is to move at all,” was clear cut and repeated in the “Letter After Final.” See Springs Window Fashions LP v. Novo Indus., L.P., 323 F.3d 989, 994-96 (Fed. Cir. 2003) (recognizing statements in prosecution history to constitute a disclaimer when such statements are “detailed, consistent, and repeated.”); cf. Tektel, Inc. v. United States, 116 Fed. Cl. 612, 624 (2013) (holding where there is “a dearth of evidence” suggesting that the Government made a scrivener’s error, the Court had no basis to conclude a scrivener’s error occurred).

Contrary to Plaintiff’s suggestion of a scrivener’s error here, the record indicates that Plaintiff wholeheartedly embraced its position that both actuators had to move for the effector base to move. First, the Applicant states that “the first effector base cannot move in response to movement of just one of the actuators, but instead requires motion of both of the actuators if the base effector is to move at all.” DCX 23 at NASA-1353. The Applicant repeats this understanding later in the Letter After Final, stating “the actuators in the present invention must be jointly controlled to obtain any usable motion of the base effector.” Id. at NASA-1354. In a clear attempt to overcome the prior art - - the Rosheim ’594 Patent that only required one actuator to effect side-to-side movement - - the Applicant explains that the requirement that both actuators move is a disadvantage to the current invention, stating “[n]othing in the Rosheim reference [’594 Patent] provides any suggestion of having the cumulative force of two actuators available to operate the digits therein.” DCX 23 at NASA-1353-54. Based on these consistent and repeated statements, the Court relies on the prosecution history disclaimer in construing “differentials in movement” to mean both actuators in the base pair must move for the effector base to wag side-to-side.

The Court Applies the Same Construction of “Differentials in Movement” for the ’962 Patent as the ’580 Patent

Passages in the ’962 specification support applying the same understanding of synchronized movement of the paired linear actuators to effect side-to-side movement of the effector base:

Extending or retracting the moveable ends of actuators **115'A** and **116'A** in unison forces effector base **111'A** toward one side or the other of palm-like structure **91'**

with the combined forces supplied by each actuator, while differentials in motions between output shafts **117'A** and **118'A** of these actuators result in side-to-side motions of effector base **111'A** plus shackle **106'A**.

'962 Patent 16:39-45 (emphasis added). The discussion of the motion of the base pair of linear actuators in the plural connotes that both actuators must extend and retract to effect differentials in motion. So too, the '962 specification's detail that the extending and retracting of both actuators would be done "in unison" reaffirms that the actuators would move in a synchronized fashion.

Moreover, although the disclaimer appears in the prosecution history of the '580 Patent and not the prosecution history of the '962 Patent, Defendant asserts that the disclaimer in the '580 Patent Application should operate as extrinsic evidence to the '962 Patent. Plaintiff does not contest this assertion. Defendant argues that "statements made in the '580 prosecution history are indicative of how one skilled in the art would understand identical claim language that is contained in the '962 Patent claims." Def.'s Post-Hr'g Br. 30. Defendant reasons that the '580 Patent prosecution history is persuasive to the interpretation of the '962 Patent because the "[l]anguage discussing the movement of paired linear actuators moving a finger from the '962 specification is very similar to the '580 specification" and because the '580 Patent is related to the '962 Patent as "they share the same sole inventor and use the same claim language." *Id.* at 29-30.

The Court agrees with Defendant. Indeed, Defendant's position is further supported by the fact that the '580 Patent is expressly listed as a prior art reference in the '962 Patent specification and the '580 Patent itself uses the term "differentials in movement." See Arthur A. Collins, Inc. v. N. Telecom Ltd., 216 F.3d 1042, 1045 (Fed. Cir. 2000) ("When prior art that sheds light on the meaning of a term is cited by the patentee, it can have particular value as a guide to the proper construction of the term, because it may indicate not only the meaning of the term to persons skilled in the art, but also that the patentee intended to adopt that meaning."). As such, the Court concludes that its understanding of "differentials in movement" based on the disclaimer in the '580 Patent also bears on the Court's construction of "differentials in movement" for the '962 Patent.

The Court's Construction of "Differentials in Movement"

Based on the unambiguous language of the prosecution history disclaimer, the Court finds that a POSITA would understand the term "differentials in movement" to mean that both linear actuators in a base pair must move in a synchronized fashion to effect the side-to-side movement of the effector base. The Court therefore adopts Defendant's construction of "differentials in movement" to mean "synchronized movement of two linear actuators in opposite directions."

"Common Movements"

The parties propose the following construction for "common movements":

Term	Plaintiff's Proposed Construction	Defendant's Proposed Construction
"common movements"	common or joint movements of two linear actuators in a similar direction	synchronized movement of two linear actuators in a similar direction

The parties' proposed constructions are nearly identical. Both parties agree that "common movements" of the linear actuator cause the individual "fingers" to move towards or away from the "palm" of the robotic hand and that such movement requires both of the two linear actuators in the base pair to move in a similar direction. The main dispute between the parties is whether the term "synchronized" in Defendant's proposed construction is applicable. Plaintiff argues that the word "synchronized" does not appear in the language of either patent-in-suit, and that synchronicity connotes "coordinating time movements" that fails to account for types of "computerized controls" described in the specifications of both patents-in-suit that pulse current to each actuator at differing times. Pl.'s Post-Hr'g Br. 22-23, 32.

The '580 and '962 Specifications

While the claim language is unclear on whether the term "common movements" means both linear actuators in a base pair must move in a synchronized fashion, the specification states that the pair of linear actuators connected to the effector bases move "in unison." The '580 specification provides with respect to the first base pair of linear actuators 180 and 181:

Linear actuators **180** and **181** are capable of forcing effector base **190** to any angle with respect to vertical within a limited angular range about the vertical in FIGS **11** and **12** [both shown above] substantially followed by the length axis of effector base **190** in the straight-up position thereof in those figures. Extending or retracting the movable ends of actuators **180** and **181** in unison forces effector base **190** forward and backward in the views of these figures with the combined forces supplied by each actuator, while differentials in the motions between the moveable ends of these actuators result in side-to-side motions of effector base **190**. As a result, combinations of such motions allow choosing any desired angle for effector base **190** within the limited range. The angular range possible for effector base **190** is clearly limited mechanically by interference between ball capture lip structure **191** and pedestal **186**, by the maximum excursion of the moveable ends of actuators **180** and **181** from the base ends thereof, and by the location of effector base **194** and the location of an opposing effector base not yet described.

'580 Patent 15:15-33 (emphasis added). The specification is dispositive that the linear actuators must extend and retract "in unison" to effect "common movements" – the motion of the effector toward and away from the palm-like structure of the hand.

With respect to the second pair of base actuators, 182 and 183, the '580 specification continues:

Here again, extending or retracting the moveable ends of actuators **182** and **183** in unison forces effector base **194** forward and backward with the combined forces of each actuator in views of these figures [**11** and **12**], while differentials in the motions between the moveable ends of these actuators result in side-to-side motions of effector base **194**.

'580 Patent 15:64 - 16:3 (emphasis added). Again, the '580 specification inserts the phrase "in unison" in reference to "common movements."

With respect to the '962 Patent, the specification provides:

[L]inear actuators **115'A** and **116'A** are capable of forcing effector base **111'A** to any angle with respect to vertical within a limited angular range about the vertical in FIGS. **5**, **10A**, **11**, **12**, and **13** [the robotic hand-like manipulator drawings] substantially followed by the extension support structure of effector base **111'A** in the straight-up position thereof in those fingers. Extending or retracting the moveable ends of actuators **115'A** and **116'A** in unison forces effector base **111'A** toward one side or the other of palm-like structure **91'** with the combined forces supplied by each actuator, while differentials in motions between output shafts **117'A** and **118'A** of these actuators result in side-to-side motions of effector base **111'A** plus shackle **106'A**. As a result, combinations of such motions allow choosing any desired angle for effector base **111'A** with respect to the above described vertical within a limited range.

'962 Patent 16:33-48. Like the '580 specification, the '962 specification only references forces operating “in unison” when moving the “effector base” or “finger” forward and backward, toward or away from the “palm-like structure.”

As detailed above, the specifications of both the '580 Patent and '962 Patent indicate that “common movements” require the base pair of linear actuators to move “in unison.” The term “in unison” is synonymous with synchronized in this context. Accordingly, the specification is dispositive that “common movements” of the linear actuators extending and retracting “in unison” or in a synchronized fashion are required to move the finger “effector bases” back and forth. See Phillips, 415 F.3d at 1315 (“[T]he specification ‘is always highly relevant to the claim construction analysis. Usually, it is dispositive; it is the single best guide to the meaning of a disputed term.’” (quoting Vitronics, 90 F.3d at 1582)).

Plaintiff’s position that computerized controls could pulse currents and activate movement of each linear actuator in its base pair at different times lacks support in the intrinsic Patents. While the '580 specification does state that the robotic manipulator is “operated at the direction of a computer,” no notion of a “pulse current” control system appears in either the claims or specification. '580 Patent 3:18-19. Further, the extrinsic testimony from Mr. Neils that it is “possible” for a computer control system to control the linear actuators with pulse currents cannot override the explicit language in the specification describing the base pair of linear actuators as extending and retracting “in unison.” Tr. 407.

The Court’s Construction of “Common Movements”

Based on the specifications, the Court finds that both linear actuators must be extending and retracting in length “in unison” to move the effector bases toward and away from the palm-like structure of the robotic hand. Defendant’s proposed modifier, “synchronized” is synonymous with “in unison” as both suggest that the base pair of linear actuators would move in identical time and rhythm. Moreover, the prosecution history disclaimer explicitly applies to both “differentials in movement” and “common movements.” Therefore, the Court considers both types of movements to require synchronicity.

The Court thus construes “common movements” to mean “synchronized movements of two linear actuators in a similar direction.”

“Shackle”

The parties request the following constructions of the term “shackle” located in Claim 14 of the ’962 Patent:

Claim term	Plaintiff’s Proposed Construction	Defendant’s Proposed Construction
“shackle”	a pair of arms spaced apart by a recess space with said arms being joined in a joining structure on one side of said recess space; <u>e.g.</u> , a U-shaped structure	a link with extended legs; each leg has a transverse hole to accommodate a pin or the like

Plaintiff argues that the term “shackle” requires no construction as the term speaks for itself, but then argues that the “shackle” should be generally construed to be a “U-shaped structure.” Pl.’s Post-Hr’g Br. 33. Defendant argues that “shackle” is a distinct structure in the patent and is required to have a connection that allows for rotational movement. Def.’s Post-Hr’g Br. 38.

The only asserted claim of the ’962 Patent involving the term “shackle” is Claim 14. It provides:

14. An articulated manipulating system for mounting on a base in a robotic manipulator and capable of engaging selected objects, said system comprising:

a plurality of shackles each having a pair of arms spaced apart by a recess space with said arms being joined in a joining structure on one side of said recess space;

a plurality of effector bases each rotatably mounted at a pivot location thereof to and between said separated arms of a corresponding shackle so as to leave a recess space between an end of that said effector base rotatably mounted to said shackle and said joining structure thereof;

a fixed pedestal affixed to said base and having said joining structure of a corresponding one of said plurality of shackles rotatably coupled thereto;

a moveable pedestal rotatably connected to said base and having said joining structure of a corresponding one of said plurality of shackles rotatably coupled thereto; and

a pedestal linear actuator coupled at one end thereof to said base and coupled at an opposite end thereof to said moveable pedestal to be capable of rotating said moveable pedestal with respect to said base.

'962 Patent 27:56 - 28:10 (emphasis added).

Claim 14 itself defines the term “shackle” as a “pair of arms spaced apart by a recess space with said arms being joined in a joining structure on one side of said recess space,” and provides for it to have rotatable connections. Because the term is already unambiguously defined in this claim, the Court need not construe the term “shackle” at all. Cent. Admixture Pharm. Servs., Inc. v. Adv. Cardiac Sols., P.C., 482 F.3d 1347, 1355 (Fed. Cir. 2007) (“Claims mean precisely what they say.”), cert. denied, 552 U.S. 1038 (2007). The language of the claim here is clear, and neither party points to any language in the specification or prosecution history that should operate to color the meaning of “shackle” to diverge from the claim language itself. As such, construction is unnecessary.

The Court’s Construction

The Court declines to construe the term “shackle” because it is already defined in Claim 14 to be “a pair of arms spaced apart by a recess space with said arms being joined in a joining structure on one side of said recess space” and also having said “arms” capable of “rotatably mount[ing]” or “rotatably coupl[ing with]” other structures.

Conclusion

For the above reasons, the Court construes the claims of the '580 and the '962 patent as follows:

“Linear actuator” means “a device, with ends defined by a base piece and an extending piece, that converts some kind of power into linear motion such that the extending piece moves in a straight line relative to the base piece.”

“Differentials in movement” means “synchronized movements of two linear actuators in opposite directions.”

“Common movements” means “synchronized movements of two linear actuators in a similar direction.”

The Court declines to construe shackle as its meaning is defined in the asserted claims.

The parties shall file a joint proposed schedule for further proceedings in this matter by **May 13, 2016**.

/s/ Mary Ellen Coster Williams
MARY ELLEN COSTER WILLIAMS
Judge