

In the United States Court of Federal Claims

No. 11-223C

Filed: May 24, 2013

AMERICAN INNOTEK, INC.,

Plaintiff,

v.

THE UNITED STATES,

Defendant.

* Patent Infringement; 28 U.S.C.
* § 1498; 35 U.S.C. § 112; Claim
* Construction; Prior Art;
* Prosecution History; Prosecution
* Disclaimer; Means-Plus-Function
* Limitation; Doctrine of
* Equivalents; Indefiniteness.
*
*

Daniel W. Ernsberger, Behrend & Ernsberger, P.C., 355 Fifth Ave., Pittsburgh, PA 15222, for Plaintiff.

Stuart F. Delery and John J. Fargo, U.S. Department of Justice, Commercial Litigation Branch, Civil Division, Washington, D.C. 20530, for Defendant. Corey R. Anthony, U.S. Department of Justice, Washington, D.C. 20530, Of Counsel.

CLAIM CONSTRUCTION OPINION AND ORDER

WILLIAMS, Judge.

This patent infringement case involves bags for the containment and disposal of bodily fluids. Plaintiff, American Innotek, Inc., the owner of U.S. Patent No. 5,116,139 (“the ’139 Patent”) entitled “Fluid Containment Bag,” manufactures a product called The Flight Extender™ according to the ’139 Patent and sold this product to the United States military from 1991 to 2001. Plaintiff claims that the United States infringed its patent by purchasing a containment bag called the “Piddle Pak” from the New York City Industries for the Blind (“NYCIB”), a non-profit entity that provides products to the Government on a noncompetitive basis pursuant to the Javits Wagner O’Day Act, 41 U.S.C. §§ 46-48c (2006). According to Plaintiff, the Piddle Pak has infringed at least some of the claims of the ’139 Patent. This matter comes before the Court following a claim construction hearing held on March 7, 2013.

Background

AbilityOne Procurements from Qualified Nonprofit Agencies Such As NYCIB

The Javits Wagner O’Day (“JWOD”) Act, now known as the “AbilityOne Program,” provides employment opportunities for people who are blind or have other significant disabilities by promoting their access to and participation in federal contracts for goods and services. See Pub. L. No. 92-28, 85 Stat. 77 (1971) (codified as amended at 41 U.S.C. §§ 46-48c (2006)).¹ Under JWOD, acquisitions for specified supplies or services can be carried out on a noncompetitive basis. See 48 C.F.R. § 6.302-5(b)(2) (2011). JWOD established the Committee for Purchase from People Who Are Blind or Severely Disabled (“the Committee”), an independent federal agency, to facilitate the Government’s “purchase of commodities and services from qualified nonprofit agencies.” 41 C.F.R. § 51-1.1(a) (2011); see 41 U.S.C. § 46(a) (2006). The Committee determines which supplies and services government entities will purchase from participating nonprofit agencies. 41 U.S.C. § 47(a)(1) (2006); see FAR 8.702. The Committee maintains a procurement list of supplies and services that must be purchased from “any qualified nonprofit agency for the blind or by any qualified nonprofit agency for other severely handicapped.” 41 U.S.C. §§ 47(a), 48 (2006); see FAR 8.703. A “qualified nonprofit agency” is an agency -- such as NYCIB -- that “employs blind or other severely handicapped individuals for not less than 75 per centum of the man-hours of direct labor required for the production or provision of the commodities or services.” 41 U.S.C. § 48b(4)(C) (2006). Once an item has been placed on the procurement list, contracting agencies are required to procure the item directly from a qualified nonprofit agency, unless the item is unavailable at the time. 41 U.S.C. § 48 (2006). The Government has purchased the Piddle Pak from NYCIB using this procurement list.

Overview of the Invention

The fluid containment bags at issue are mainly used by pilots during long-distance flights to hold urine. The military is one of the largest purchasers of these containment bags. The bags generally consist of a plastic bag fitted with a funnel to direct the bodily fluid into the bag, and a hydrophilic powder to absorb bodily fluid and turn it into a gel to prevent spillage.

The military specification for the bag required the following test:

4.4.2 Inverted leakage test.

The bag shall be filled with a minimum of 550 cm³ of water and, without closing, quickly inverted. There shall be no more than 30 cm³ of liquid spilled from the opening during a one-minute period.

Pl.’s Claim Construction Br. (“Pl.’s Br.”) 1.

¹ In 2011, the United States Code was renumbered pursuant to Pub. L. No. 111-350, 124 Stat. 3835 (2011) such that JWOD is now codified at Chapter 85 of Title 41. The Court uses the 2006 version of the Code, the version in effect when Plaintiff filed its complaint.

Patent Prosecution History

The application for the '139 Patent was filed on February 15, 1991, as a continuation-in-part of application No. 07/404,734, filed on September 8, 1989. Application No. 07/404,734 was itself a continuation-in-part of application No. 07/003,848, filed on January 14, 1987. Def.'s Claim Construction Br. ("Def.'s Br."), Ex. 1 at A2. The January 1987 application disclosed:

A waste disposal bag for human waste, particularly for body fluids such as urine, comprises an impermeable flexible bag having an enlarged inlet at the top and a funnel extending from the top into the interior of the bag with an elongated slit tube clamp that slideably engages the top of the bag around the opening to clamp the bag in the closed position. A quantity of hydrophilic material for absorbing and bonding the liquid waste deposited in the bag is contained in the bag.

Def.'s Br., Ex. 5 at A160. The application listed Ruth E. Young as the inventor, and asserted 20 claims. Id. at A168-75. The patent examiner determined that all 20 claims were unpatentable over prior art because of obviousness. Id. at A178-79. The patent examiner noted that it was obvious to use a container with a funnel, that a tear-drop configuration with a tube was an obvious extension of a previous invention, and that binder powders were "well-known in the art." Id.²

Application No. 07/404,734 was filed on September 8, 1989. Def.'s Br., Ex. 4 at A32-60. The application listed Ruth E. Young, Daniel L. Young, Richard E. Warrick, and Clarence A. Cassidy as the inventors. Id. at A32. The application contained 13 drawings and asserted 36 claims. Id. at A32-60. On March 5, 1990, the patent examiner rejected claims 1-33, and objected to claims 34-36. Id. at A61-64. The patent examiner found that use of hydrophilic material, the use of a cooperating rib closure, the use of a tube, and providing a closure to allow one-handed use were obvious based on prior art. Id. at A62-64. An amendment to application No. 07/404,734 was filed on June 5, 1990, in response to the patent examiner's decision. Id. at A65-72. The amendment stated that the funnel was spaced apart from the sides of the bag, and was adapted to prevent backflow of fluid through the funnel. Id. at A66.

In distinguishing the invention covered by the '139 Patent from another earlier urine collection bag invention, U.S. Patent No. 3,403,715 (filed October 1, 1968) referred to as "Trudel," the amendment stated:

It will be seen that Trudel has a bag structure in which the passages 38 for the fluid into the container portion 10 of Trudel's bag are formed as an integral part of the sides of the container itself. Thus, if the bag is inverted, liquid can

² Plaintiff filed an amendment to application No. 07/003,848 on July 17, 1987. Def.'s Br., Ex. 5 at A180-92. The patent examiner rejected the revised claims for obviousness. Id. at A194-97. Plaintiff appealed the patent examiner's decision, id. at A202-03, but later abandoned application No. 07/003,848 in favor of continuation-in-part application No. 07/404,734. Id. at A236.

return back through the passages 38 since there is no physical separation between the passages and the container 10 of the bag. This deficiency is recognized by Trudel, and he tries to compensate by provision of flaps 17 to catch the return liquid which flows back through passages 38 rather than being trapped by pockets 39 or 40.

...

In Applicants' bag, however (as is made clear and emphasized by the amendments to the claims), the internal funnel means is a completely separate structure which is spaced apart from the container and the bag sides Thus, liquid which may not be absorbed by the internal absorbent and which may flow back toward the top of the bag is diverted away from the funnel and passes along the sides of the bag to be entrapped between the funnel and the bag.

Thus, where Applicants' funnel opening 30 is spaced apart from the bag itself and therefore not reachable by any back flowing liquid, Trudel's passages 38 are integral with the sides of the bag and offer no barrier to reverse flow of the liquid.

Applicants' claimed bag with its separate funnel structure, therefore, is clearly a different and far superior structure to Trudel's one piece bag.

...

In summary, therefore, Applicants respectfully submit that while the intended end use of the two bags is similar, it is evident that the specific bag structure claimed in Applicants' amended claims is substantially different from and far superior to the structure shown in the Trudel reference. . . .

Def.'s Br., Ex. 4 at A69-71 (emphasis in original). A distinction from Trudel is that Trudel is constructed from two pieces of plastic, not four, such that the walls of the funnel are also the walls of the fluid containment bag. Therefore, the funnel in Trudel is not a separate structure as it is in the '139 Patent. In Trudel, closure of the funnel is achieved through tension created by filling pockets alongside the funnel with fluid. By comparison, the funnel in the '139 Patent is closed by pressure applied from the fluid coming between the side of the bag and the funnel.

The patent examiner once again denied the September 1989 patent application for obviousness. Def.'s Br., Ex. 4 at A73-77. The patent examiner determined that this version of the invention was not distinguishable from both Trudel and another prior invention "Corella et al.," stating:

The claims are considered to be met by Trudel except that Trudel does not disclose placing a hydrophilic material within the bag to sequester bodily fluids. Trudel also does not disclose making the funnel means [a] completely separate structure.

...

Corella et al. teaches a funnel structure where the open bottom is spaced apart from the side of an analogous bag in order to alleviate the leaking problems associated with bags whose funnel structures rely on side tensioning of a filled bag to close it. It would have been obvious to one having ordinary skill in the art to replace the funnel structure of Trudel with the non-integral funnel structure of Corella et al. in order to prevent the backflow of fluid entering the bag through the funnel structure, taught to be desirable by Corella et al.

Def.'s Br., Ex. 4 at A74-75.

The examiner also rejected some claims as obvious in view of another invention referred to as "Benzel et al.," where the only difference between the '139 Patent and Benzel et al. was that the '139 Patent used a hydrophilic powder, and Benzel used a sponge. The structure of the fluid containment bag, including the funnel, was substantially the same. Id. at A121.

On July 25, 1991, Plaintiff had an interview with the Patent and Trademark Office ("PTO") to try to reach an agreement on allowable claims. Id. at A122. During the meeting with the assigned Patent Examiner and the Supervisory Patent Examiner, Plaintiff demonstrated the technology, and Plaintiff discussed ways to reword the claims with the PTO. Id. The patent examiners advised Plaintiff that claim 39, which disclosed the funnel, would be allowed if it was rewritten "to recite that liquid can get behind at least a portion of the walls of the funnel to close funnel." Id. Further, the patent examiners advised that a claim reciting specific particle size appeared to be allowable because it achieved a faster gel time than another prior invention, referred to as "Barthell et al." Id.

On September 11, 1991, Plaintiff submitted an amendment and a response to the pending rejection. Plaintiff added claim 62, which provided:

62. A containment bag for bodily fluids which comprises:

a bag having a hollow interior defined by two sides meeting at opposite edges, a bottom and a top, with said edges and bottom sealed and said top at least partially open to receive said bodily fluids;

a gellable hydrophilic material within said bag, said material becoming fully gelled within thirty seconds of said contact with said bodily fluids when said bodily fluids are deposited in said bag, said gellation serving to essentially completely sequester said bodily fluids and prevent said bodily fluids from thereafter being expelled from said bag;

funnel means within said interior and having an open top, said funnel means being secured to said bag at said top of said bag, and extending downwardly within said interior to a narrower open bottom for conduction of fluid entering said open top through said funnel means and into said bag, with the open bottom of said funnel being disposed intermediate between said top and bottom of said bag, said open bottom being free from attachment to said sides of said bag such that flow of any unsequestered fluid within said bag back toward

said funnel means acts to close said funnel means to prevent escape of said unsequestered fluid from said bag; and

closure means for closing the top of said bag after introduction of said bodily fluids into said bag.

Def.'s Br., Ex. 4 at A124. In the application to amend, Plaintiff wrote:

1. Amendments to the Claims:

As part of the amendments herein, Applicants have replaced Claim 39 with new Claim 62, which incorporates the limitations of Claim 39 plus a clarification of the structure of the bag relating to its ability to prevent escape of non-sequestered fluid by means of such fluid itself acting to close the funnel means. . . .

Applicants have also herein amended Claims 28 and 57, the two other independent claims previously in the application, to characterize and distinguish the novel structure of the bag itself. Applicants have incorporated language which defines the funnel as being closed by the back flow of fluid, which effectively seals the funnel and prevents escape of the fluid from the interior of the bag, regardless of the orientation of the bag. . . .

2. Distinctions over Prior Art:

Claims 62 and 65 and their dependent claims define a structure which is not made obvious by the combination of Trudell in view of Barthell et al. and Corella et al. . . . Clearly this combination of references does not teach or suggest Applicants' self-closing bag with its rapid-gelling material and ability to prevent escape of liquid either by sequestration or by entrapment.

. . .

Applicants also respectfully submit that the other aspects of the invention involving the bag structure itself as claimed in amended Claims 38 and 57, new independent Claims 72 and 82, and their dependent claims are also patentable over the prior art. None of the cited references or the prior art products shows a one-way valve bag structure which prevents release of fluid by having the fluid itself serve to prevent its own leakage by closing the channel or funnel into the bag. . . .

Def.'s Br., Ex. 4 at A131-34; Pl.'s Br., Ex. 1 at 316-19.

The PTO issued a Notice of Allowability on December 19, 1991, finding that claim 62, and dependent claims 41-56 were allowable with an examiner's amendment. Def.'s Br., Ex. 4 at A137-40. The examiner's amendment deleted the words "bodily fluids" from claims 38-41, replaced "human bodily fluids" with "a fluid comprising water or water-based liquids such as human bodily fluids" in the first line of claim 62, and replaced "bodily fluids" with "fluid"

throughout the rest of claim 62. Id. at A138-39. Claim 62, as amended by the examiner's amendment, became claim 1 of the '139 Patent.

Discussion

Jurisdiction

The Court has subject-matter jurisdiction over this action pursuant to 28 U.S.C. § 1498(a), which provides in relevant part:

Whenever an invention described in and covered by a patent of the United States is used or manufactured by or for the United States without license of the owner thereof or lawful right to use or manufacture the same, the owner's remedy shall be by action against the United States in the United States Court of Federal Claims for the recovery of his reasonable and entire compensation for such use and manufacture.

28 U.S.C. § 1498(a) (2006). Because the Government purchased the accused device, the Piddle Pak, from NYCIB, the Court has jurisdiction over this action.

Legal Standards for Claim Construction

The Court's determination of patent infringement follows a two-step process. "[T]he court first interprets the claims to determine their scope and meaning." Presidio Components, Inc. v. Am. Technical Ceramics Corp., 702 F.3d 1351, 1358 (Fed. Cir. 2012) (citing Cybor Corp. v. FAS Techs., Inc., 138 F.3d 1448, 1454 (Fed. Cir. 1998) (en banc)). Next, the court in a § 1498(a) action compares the properly construed claims to the allegedly infringing device.³ Cybor Corp., 138 F.3d at 1454.

A "bedrock principle" of patent law is that "the claims of a patent define the invention to which the patentee is entitled the right to exclude." Phillips v. AWH Corp., 415 F.3d 1303, 1312 (Fed. Cir. 2005) (en banc) (quoting Innova/Pure Water, Inc. v. Safari Water Filtration Sys. Inc., 381 F.3d 1111, 1115 (Fed. Cir. 2004)). The language of these claims is often apparent on its face, but can be complicated by the human failings of the written word and the inclusion of highly technical terminology. As the Federal Circuit ruled, it is up to the Court to construe such claims as a matter of law. See Cybor Corp., 138 F.3d at 1454. "Claim construction is a matter of resolution of disputed meanings and technical scope, to clarify and when necessary to explain what the patentee covered by the claims, for use in the determination of infringement." U.S. Surgical Corp. v. Ethicon, Inc., 103 F.3d 1554, 1568 (Fed. Cir. 1997). When construing claims, this Court must furnish "sufficient findings and reasoning to permit meaningful appellate scrutiny." OSRAM Sylvania, Inc. v. Am. Induction Techs., Inc., 701 F.3d 698, 707 (Fed. Cir. 2012) (quoting Nazomi Commc'ns, Inc. v. Arm Holdings, PLC, 403 F.3d 1364, 1371 (Fed. Cir. 2005)).

³ Unlike in patent infringement litigation between private parties, there are no juries in § 1498(a) actions where the federal government is the defendant.

The first step in construing a claim is to “look to the words of the claims themselves . . . to define the scope of the patented invention.” Vitronics Corp. v. Conceptor, Inc., 90 F.3d 1576, 1582 (Fed. Cir. 1996). The words are not read from the perspective of the average, uninformed person, but from the perspective of “a person of ordinary skill in the art.” Phillips, 415 F.3d at 1313. Here, the Court endeavors to construe these claims as a hypothetical person who is presumed to have ordinary skill in the designing and making of disposable fluid containment devices.

The legal formulation of a claim’s construction is not performed in a vacuum. It requires examining evidence of the claim’s meaning. Intrinsic evidence consists of the patent and its file history, including any reexaminations and reissues, as well as any related patents and their prosecution histories. See IMS Tech., Inc. v. Haas Automation Inc., 206 F.3d 1422, 1433 (Fed. Cir. 2000); see generally, Phillips, 415 F.3d at 1314-1317. A patent is comprised of several components. Two key components of a patent are the claims and the specification. The claims “define the invention to which the patentee is entitled the right to exclude.” Phillips, 415 F.3d at 1312 (quoting Innova, 381 F.3d at 1115). The specification “contain[s] a written description of the invention, and of the manner and process of making and using it.” 35 U.S.C. § 112, ¶ 1.⁴ The “specification ‘is always highly relevant to the claim construction analysis. Usually, it is dispositive; it is the single best guide to the meaning of a disputed term.’” Phillips, 415 F.3d at 1315 (quoting Vitronics, 90 F.3d at 1582). In addition, the specification provides insight into how the inventor and patent examiner understood the patent. Id. at 1315-16.

Another important source of intrinsic evidence for purposes of claim construction is the prosecution history, which consists of “the complete record of the proceedings before the PTO and includes the prior art cited during the examination of the patent.” Id. at 1317. At the same time, the Federal Circuit has acknowledged that a patent’s prosecution history can be ambiguous, and thus less useful in claim construction. See id.; Inverness Med. Switz. GmbH v. Warner Lambert Co., 309 F.3d 1373, 1380-82 (Fed. Cir. 2002).

Extrinsic evidence refers to all other types of evidence, and includes inventor testimony, expert testimony, dictionaries and learned treatises. Phillips, 415 F.3d at 1317. “[W]hile extrinsic evidence can shed useful light on the relevant art,” the Federal Circuit has established “that it is less significant than the intrinsic record in determining the legally operative meaning of claim language.” Id. (internal quotations omitted).

⁴ Section 112 of Title 35 of the United States Code was revised as of September 16, 2011, to designate each of the previously undesignated paragraphs, and to conform terminology with changes made in other parts of Title 35. Leahy-Smith America Invents Act, Pub. L. No. 112-29, § 4(c), 125 Stat. 284, 296 (2011). These changes do not otherwise alter 35 U.S.C. § 112 with respect to the issues addressed in this case. Nevertheless, the pre-September 16, 2012 version of § 112 applies here because the ’139 Patent issued prior to that date and the Leahy-Smith Act provides that the amendments apply only to new patent applications. See § 4(e), 125 Stat. at 297 (“The amendments made by this section shall take effect upon the expiration of the 1-year period beginning on the date of the enactment of this Act and shall apply to any patent application that is filed on or after the effective date.”).

Independent Claim 1

There are four claims in the '139 patent requiring construction by the Court, with the principal claim at issue being independent claim 1. Within independent claim 1, there are three specific phrases the parties have requested the Court interpret, “free from attachment to said sides of said bag,” “unsequestered fluid,” and “closure means for closing the top of said bag.” The complete independent claim 1, with the language at issue highlighted, reads:

A containment bag for a fluid comprising water or water-based liquid such as bodily fluids which comprises:

a bag having a hollow interior defined by two sides meeting at opposite edges, a bottom and a top, with said edges and bottom sealed and said top at least partially open to receiving said;

a gellable hydrophilic material within said bag, said material becoming fully gelled within thirty seconds of said contact with said fluid when said is deposited in said bag, said gellation serving to essentially completely sequester said and prevent said fluid from thereafter being expelled from said bag;

funnel means within said interior and having an open top, said funnel means being secured to said bag at said top of said bag, and extending downwardly within said interior to a narrower open bottom for conduction of fluid entering said open top through said funnel means and into said bag, with the open bottom of said funnel being disposed intermediate between said top and bottom of said bag, ***said open bottom being free from attachment to said sides of said bag*** such that flow of any ***unsequestered fluid*** within said bag back toward said funnel means acts to close said funnel means to prevent escape of said ***unsequestered fluid*** from said bag; and

closure means for closing the top of said bag after introduction of said fluid into said bag.

'139 Patent, Def.'s Br., Ex. 1 at A9, col. 8, ll. 39-66 (emphasis added).

“Free From Attachment to Said Sides of Said Bag”

The parties request the following constructions:

Patent Language	Plaintiff’s Proposed Construction	Defendant’s Proposed Construction
Independent claim 1: “said open bottom being free from attachment to said sides of said bag” '139 Patent, Def. Ex. 1 at A9, col. 8, ll. 59-61.	““Being free from attachment to said sides’ means free from attachment to the ‘sides’ not ‘edges.’” Pl.’s Reply to Def.’s Claim Construction Chart, Ex. 1 at 1.	“The open bottom of the funnel means is not attached to the sides of the bag at any point, including the edges, so that the internal funnel means is a completely separate structure, which is spaced apart from the bag sides, except where it is attached at the top of the bag[.]” Def.’s Br. 22.

Prosecution History

Defendant relies on the prosecution history for the '139 Patent for its position that the funnel is a completely separate structure and not attached to the bag at any point except the top. Defendant contends that Plaintiff emphasized that the funnel was separate from the bag during the prosecution of the '139 Patent, and that such emphasis establishes that “free from attachment to said side” means not attached to the side of the bag at all.

Defendant points to the amendment of precursor Claim 19 to argue that the prosecution history demonstrates that the funnel must be free from attachment to the edges because the amended Claim 19 had used the words “spaced apart from said sides of said bag.” Claim 19 originally described the funnel as:

having an open top integrated and substantially coextensive with said top of said bag, and extending downwardly within said interior, with the open bottom of said funnel being disposed intermediate between said top and bottom of said bag

Def.’s Br., Ex. 4 at A50. Defendant concludes:

The examiner rejected claim 19 as obvious in light of the Trudel and Barthell references. [*Id.*] at A62, Def. Bates No. 000071. To overcome this rejection, defendant amended claim 19. *Id.* at A66, Def. Bates No. 000138, (“with the open bottom of said funnel being . . . spaced apart from said sides of said bag and adapted to prevent backflow of fluid . . .” (emphasis in original)).

Def.’s Br. 19.

Plaintiff counters by citing an examiner's note suggesting that the funnel could be partially attached to the edges. As Plaintiff points out, "[t]he examiner found it was [only] necessary for the liquid to get behind a portion of the walls to close the funnel. (see Exhibit 1 at Bates No. 307)." Pl.'s Br. 6. Thus, in Plaintiff's view, by not requiring that fluid get behind all walls of the funnel to close the funnel, the examiner's note suggests that the language regarding "free from attachment" was not an absolute freedom, but that freedom from attachment to the sides of the bag would be sufficient. Pl.'s Br. 7. In the cited note, the examiner stated:

Claim 39, re-written, with modification to recite that liquid can get behind at least a portion of the walls of the funnel to close funnel would be allowed upon commercial success showing.

Pl.'s Br., Ex. 1 at Bates No. 307; Def.'s Br., Ex. 4 at A122. Thus, as Plaintiff suggests, the funnel structure could have been partially attached to the edges such that the liquid only needed to get behind a portion of the walls to close the funnel. Otherwise, if it had been necessary for the fluid to get behind the entirety of the walls of the funnel to close the funnel, the funnel could not have been attached to the edges of the bag at all. The examiner's acknowledgment that fluid only had to "get behind at least a portion of the walls of the funnel" negates Defendant's proposed construction.

In sum, the prosecution history does not support Defendant's claim construction. In arguing that free from attachment to the sides means free from attachment to the entire span of both edges, Defendant ignores the language in the earlier iteration of the claim that "spaced apart" applied to the "open bottom" of the funnel, not the entire funnel. Def.'s Br., Ex. 4 at A66. Further, the prosecution history indicates the patent examiner's understanding that the liquid could "get behind at least a portion of the walls," not the entirety of the walls, meaning the funnel could be partially attached to the edges.

Prosecution Disclaimer

Again citing prosecution history, Defendant further asserts that "plaintiff disclaimed any interpretation that *free from attachment to the sides* means free from attachment to the sides but not the edges." Def.'s Br. 21 (emphasis in original). The legal standard for finding a prosecution history disclaimer requires "a clear and unmistakable disavowal of scope during prosecution." Purdue Pharma L.P. v. Endo Pharms. Inc., 438 F.3d 1123, 1136 (Fed. Cir. 2006). Such a finding of disclaimer is based on "whether a competitor would reasonably believe that the applicant had surrendered the relevant subject matter." PODS, Inc. v. Porta Stor, Inc., 484 F.3d 1359, 1368 (Fed. Cir. 2007) (quoting Cybor Corp., 138 F.3d at 1457); see also Omega Eng'g, Inc. v. Raytek Corp., 334 F.3d 1314, 1325 (Fed. Cir. 2003).

Defendant cites Omega Engineering and PODS, Inc. in support of its position, arguing:

The prosecution history of the '139 Patent clearly indicates that plaintiff disavowed that the funnel can be attached at any point other than the top of the bag. Similar to the patentee in PODS, plaintiff amended the funnel structure multiple times in an attempt to overcome the examiner's rejections. In one amendment plaintiff described the funnel as integrated with the top of the bag and

“spaced apart” from the sides. Def. Ex. 4 at A66, Def. Bates No. 000138. In the accompanying remarks plaintiff stated that the funnel in the Trudel bag is “an integral part of the sides of the container” while plaintiff’s funnel “is a completely separate structure.” *Id.* at A69-70, Def. Bates No. 000141-42. . . . Plaintiff subsequently amended the funnel limitation replacing “spaced apart” with “free from attachment.” The above remarks and amendments by the plaintiff demonstrate a clear intent to disavow any claim to a structure where the funnel is attached to the bag at any point except the top. Because a competitor could reasonably believe that plaintiff had surrendered any claim to attachment of the funnel at the side edges, plaintiff’s construction is barred by prosecution disclaimer.

Def.’s Br. 23.

Defendant has failed to prove a clear and unmistakable disavowal that the funnel could be attached at any point other than the top of the bag. Indeed, Plaintiff points to a statement made by the applicant in the prosecution history relating to the funnel:

In Applicants’ bag, however (as is made clear and emphasized by the amendments to the claims), the internal funnel means is a completely separate structure which is spaced apart from the container and the bag sides (as illustrated best in figures 3 and 5) . Thus, liquid which may not be absorbed by the internal absorbent and which may flow back toward the top of the bag is diverted away from the funnel and passes along the sides of the bag to be entrapped between the funnel and the bag.

Pl.’s Br., Ex. 1 at Bates No. 142; Def.’s Br., Ex. 4 at A70 (emphasis in original). The illustrations referenced in this passage (figures 3 and 5) are reproduced below:

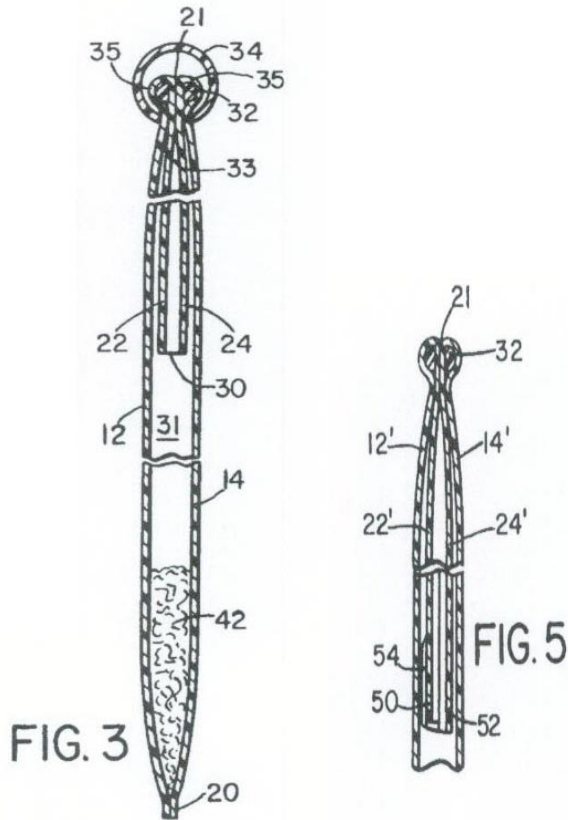

Def.'s Br., Ex. 1 at A3. Plaintiff elaborates:

In Figure 3, sides of the funnel are identified by numbers 22, and 24. The sides of the bag are identified by numbers 12 and 14. There is a space visible between the sides of the funnel and the sides of the bag. This is what is meant by “being free from attachment from said sides”. Similarly, in Figure 5, the sides of the funnel are identified by numbers 22' and 24'. The sides of the bag are identified by numbers 12', and 14'. There is a space visible between the sides of the funnel and the sides of the bag. This is what is meant by “being free from attachment from said sides”.

Pl.'s Br. 8-9. Both the applicant's prosecution statement and the referenced figures depict the “freedom from attachment” as applying to the sides; no mention is made of “freedom of attachment” with respect to the edges. As such, there is no basis to find Defendant's suggested prosecution history disclaimer here.

The Court's Construction

The parties' only disagreement in the construction of the language is whether the word "sides" includes the edges. Tr. 80.⁵ The language of the patent as a whole supports Plaintiff's position that the "sides" are to be considered distinct from the edges. The language in the patent differentiates between "sides" and "edges," particularly in the claims themselves. See CAE Screenplates, Inc. v. Heinrich Fiedler GmbH & Co. KG, 224 F.3d 1308, 1317 (Fed. Cir. 2000) (holding that "[i]n the absence of any evidence to the contrary, we must presume that the use of . . . different terms in the claims connotes different meanings"). Independent claim 1 states that the bag is "defined by two sides meeting at opposite edges, a bottom and a top, with said edges and bottom sealed." '139 Patent, Def.'s Br., Ex. 1 at A9, col. 8, ll. 42-44. Thus, in describing the containment bag at issue, the claim defines the landmarks by which the claim is to be understood distinctly, with the "sides" being the front and back of the containment bag, the "edges" being the junctions at the left and right of the containment bag, and the "top" and "bottom" being the junctions at the head and foot of the bag.

Further, the '139 Patent states that "[t]he invention herein will be best understood by reference to the drawings" '139 Patent, Def.'s Br., Ex. 1 at A7, col. 3, ll. 51-52. Figure 8 provides an example of a funnel with the entire length of its structure being attached along one of the edges, marked as 18, with the opening, marked as 30, positioned alongside the same edge.

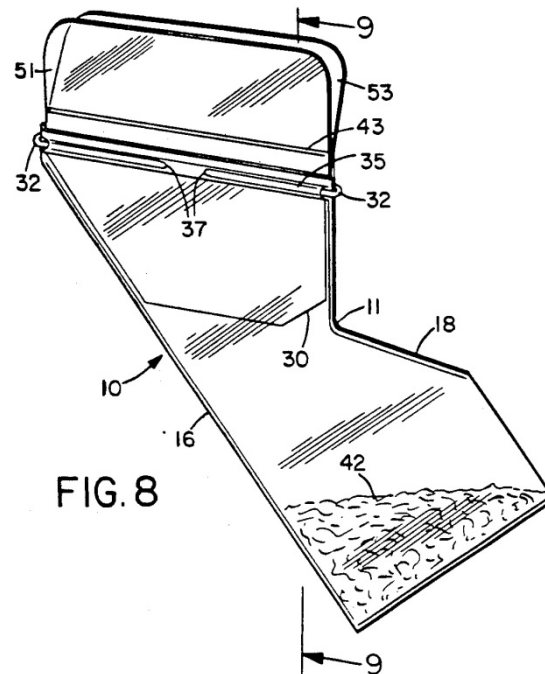

Def.'s Br., Ex. 1 at A4.

⁵ All references to the transcript in this opinion are to the claim construction hearing held on March 7, 2013. The parties did not put on any evidence at that hearing, but counsel argued their proposed claim constructions for each term at issue.

Figure 13 also shows a funnel structure attached to the edges (designated by the black arrow), while still being free from attachment to the sides.

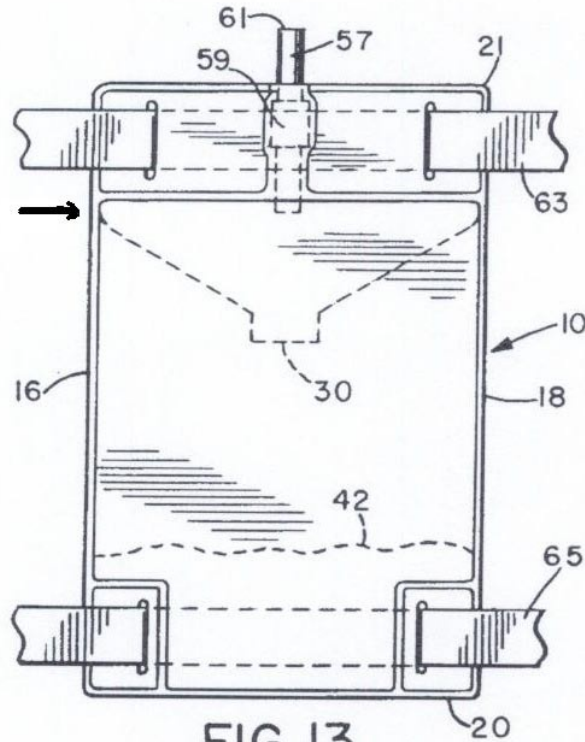

FIG. 13

Def.'s Br., Ex. 1 at A5.

In light of these considerations, the Court agrees with Plaintiff's proposed construction, and construes the claim language as follows:

The language in Independent claim 1 that reads "said open bottom being free from attachment to said sides of said bag," should be interpreted to cover any containment bag where the open bottom of the funnel is free from attachment to said sides, but is not necessarily free from attachment to the edges.

“Unsequestered Fluid”

The parties request the following constructions:

Patent Language	Plaintiff’s Proposed Construction	Defendant’s Proposed Construction
Independent claim 1: “unsequestered fluid” '139 Patent, Def. Ex. 1 at A9, col. 8, ll. 61 and 64.	“[A]n ‘unsequestered fluid’ is a ‘fluid’ that contains some ‘hydrophilic material’ which has not yet gelled.” Pl.’s Claim Construction Reply Br. 5.	“‘[U]nsequestered fluid’ is ‘water based liquids, including bodily fluids that have not yet gelled.’” Def.’s Response to Pl.’s Br. 15.

To support its construction, Plaintiff argues:

[T]he unsequestered fluid is no longer just a pure liquid, it is mixed with the powder and that does not flow out. And so the functional aspect of the patent is that the fluid has been altered in its composition so it doesn’t flow out anymore. And so an unsequestered fluid is not simply a fluid. An unsequestered fluid is a mixture of the fluid that was poured into the bag and the powder which is in the process of gelling.

Tr. 45. Defendant states that “[t]he plain and ordinary meaning of the term *unsequestered fluid* is fluid that has not yet been gelled.” Def.’s Br. 29. In response to Plaintiff’s construction, Defendant argues that “the term ‘fluid’ cannot include the ‘hydrophilic powder’ because both terms are used in the claims.” Def.’s Br. 30 (citing CAE Screenplates, 224 F.3d at 1317).

The Court’s Construction

The parties disagree over whether “unsequestered fluid” can contain hydrophilic material. Plaintiff submits that it can. In contrast, Defendant contends that the term “fluid” cannot include “hydrophilic material” because both terms are used in the claims. However, Defendant attempts to read a key term of the patent -- hydrophilic material -- out of the construction of “unsequestered fluid.” It is clear from the claim as a whole and the parties’ proposed constructions that hydrophilic material is an important element of the bag, and a critical component of the combination of fluid with hydrophilic material which in 30 seconds causes gellation and sequestration. The claim itself expressly states that it is hydrophilic material that causes gelling due to its “contact” with “said fluid.”

It is well established that “the claims themselves provide substantial guidance as to the meaning of particular claim terms.” Phillips, 415 F.3d at 1314; see also ACTV, Inc. v. Walt Disney Co., 346 F.3d 1082, 1088 (Fed. Cir. 2003) (“[T]he context of the surrounding words of the claim also must be considered in determining the ordinary and customary meaning of those

terms.”); Vitronics, 90 F.3d at 1582. So too, “the context in which a term is used in the asserted claim can be highly instructive.” Phillips, 415 F.3d at 1314. “While certain terms may be at the center of the claim construction debate, the context of the surrounding words of the claim also must be considered in determining the ordinary and customary meaning of those terms.” ACTV, 346 F.3d at 1088; see Brookhill-Wilk 1, LLC v. Intuitive Surgical, Inc., 334 F.3d 1294, 1299 (Fed. Cir. 2003); Hockerson-Halberstadt, Inc. v. Converse Inc., 183 F.3d 1369, 1374 (Fed. Cir. 1999). Given this precedent and the language of claim 1, it is inappropriate to ignore the words “hydrophilic material” in construing the term “unsequestered fluid.”

The claim itself states:

A containment bag for a fluid comprising water or water-based liquid such as bodily fluids which comprises:

a bag having a hollow interior defined by two sides meeting at opposite edges, a bottom and a top, with said edges and bottom sealed and said top at least partially open to receiving said;

a gellable hydrophilic material within said bag, said material becoming fully gelled within thirty seconds of said contact with said fluid when said is deposited in said bag, said gellation serving to essentially completely sequester said and prevent said fluid from thereafter being expelled from said bag;

funnel means within said interior and having an open top, said funnel means being secured to said bag at said top of said bag, and extending downwardly within said interior to a narrower open bottom for conduction of fluid entering said open top through said funnel means and into said bag, with the open bottom of said funnel being disposed intermediate between said top and bottom of said bag, said open bottom being free from attachment to said sides of said bag such that flow of any unsequestered fluid within said bag back toward said funnel means acts to close said funnel means to prevent escape of said unsequestered fluid from said bag; and

closure means for closing the top of said bag after introduction of said fluid into said bag.

'139 Patent, Def.'s Br., Ex. 1 at A9, col. 8, ll. 39-66.

The “unsequestered fluid” term at issue refers back to “fluid” which has not yet gelled until after its “contact” with hydrophilic material. As the second subparagraph of the claim makes clear, it is the hydrophilic material’s contact with the fluid that causes the gellation, and the gellation which in turn sequesters the fluid. According to the second subparagraph, hydrophilic material could mix with the fluid but not form a gel prior to the 30-second time frame. Defendant agreed that unsequestered fluid would contain hydrophilic powder particles, “because it would be kind of hard for it not to.” Tr. 91. As such, a reference to the presence of hydrophilic material is critical for an understanding of the term “unsequestered fluid” according to the language of the claim itself.

Further, although there are separate terms in the claim for “fluid” and “hydrophilic material,” it would be an oversimplification of the claim language to ignore how these terms interrelate. The ’139 Patent describes how the hydrophilic material is “gellable,” and specifies a timeframe (30 seconds) by which the hydrophilic material and the fluid join in a state of “gellation.” *Id.* at ll. 46-51. The fluid mixed with the hydrophilic material prior to gelling would necessarily entail the fluid having some hydrophilic particles in the state of not yet being fully gelled. Indeed, the patent itself clearly contemplates a time frame during which precisely this state occurs, the referenced 30-second period.

For the above reasons, the Court construes the claim language as follows:

The language in Independent claim 1 that reads “unsequestered fluid,” should be interpreted to mean water or water-based liquids such as bodily fluids containing some hydrophilic material that have not yet gelled.

“Closure Means for Closing the Top of Said Bag”

This is a method for permanently sealing the bag after use for long term storage. The parties request the following constructions:

Patent Language	Plaintiff’s Proposed Construction	Defendant’s Proposed Construction
Independent claim 1: “closure means for closing the top of said bag” ’139 Patent, Def. Ex. 1 at A9, col. 8, l. 65.	“[A]ll ‘closure means for closing the top of said bag after introduction of said fluid into said bag’ known in the art, and certainly no less than all closure means that use <u>any</u> clamp or snap and seal zipper known in the art.” Pl.’s Br. 15 (emphasis in original).	“Clamp 34 or zipper closure 43, and equivalents thereof for closing the opening extending from one side edge to the opposite side edge.” Def.’s Br. 32.

The parties agree that the language used in the claim “closure means for closing the top of said bag” is in the form of a “means-plus-function” claim. ’139 Patent, Def. Ex. 1 at A9, col. 8, line 65. As the Federal Circuit has recognized, “if the word ‘means’ appears in a claim element in association with a function, [the presumption is that] § 112, ¶ 6 applies. This presumption collapses, however, if the claim itself recites sufficient structure, material, or acts to perform the claimed function.” *Micro Chem., Inc. v. Great Plains Chem. Co., Inc.*, 194 F.3d 1250, 1257 (Fed. Cir. 1999) (internal citations omitted). Construction of means-plus-function claims are governed by 35 U.S.C. § 112, ¶ 6 (2006):

An element in a claim for a combination may be expressed as a means or step for performing a specified function without the recital of structure, material, or acts in support thereof, and such claim shall be construed to cover the corresponding structure, material, or acts described in the specification and equivalents thereof.

35 U.S.C. § 112, ¶ 6. Therefore, construing a means-plus-function claim requires identifying “the claimed function [in the specification] and identif[y]ing the structure in the written description necessary to perform that function.” Micro Chem, 194 F.3d at 1258.

The parties also recognize “that, ‘[p]ursuant to 35 U.S.C. § 112[, ¶ 6], a means-plus-function limitation is not restricted to the structures disclosed in the specification but includes structures that are the equivalents thereof.’” Pl.’s Claim Construction Reply Br. 5 (quoting Def.’s Br. 32). Plaintiff, however, argues for a broad reading of what structures are encompassed by the “closure means,” stating:

The court can receive a broad interpretation of “equivalence” or a narrow interpretation of “equivalence” depending on the “context of the invention.” The broad or narrow scope depends on whether the claim limitation is critical to the claim. IMS Technology Inc., v. Haas Automation Inc., 206 F3d 1422,1436, 54 USPQ 2d 1129 (Fed. Cir. 2000). In this case, the “closure means” was not critical to claim one. What was critical to the claim was discussed by the Patent Examiner. The critical feature of claim one was the way in which the funnel works to channel the bodily fluids from the open top down into the interior of the bag, and the way in which the funnel restricts the expulsion of the bodily fluids from the interior prior to the sequestration of the bodily fluids. . . . The “closure means” is a separate and distinct clause in claim one.

Pl.’s Claim Construction Reply Br. 6-7.

Defendant argues for a narrow construction that the claim limitation should be construed as “clamp **34** or zipper closure **43**, and equivalents thereof.” Def.’s Resp. to Pl.’s Br. 12 (emphasis in original). Defendant states that “the elongated clamp designated as clamp **34** and the zipper closure **43**—provide the yardstick by which an ‘equivalent thereof’ is to be determined. That is the import of the Federal Circuit’s cases, as well as the plain language of section 112[, ¶ 6].” Id.

In response to Plaintiff’s argument that the closure means should be construed broadly, Defendant states:

In the hope of meeting the requirements set forth in *IMS Tech.*, plaintiff minimizes the role that the closure means had in the claims ultimately being allowed. . . .

Plaintiff offers no evidence that the product’s commercial success would have been unchanged if a means for securely closing the bag after use was not included in the design. To the contrary this claim limitation is a critical feature to the commercial success of plaintiff’s bodily fluids containment product. If not for the “closure means,” unsequestered fluid and the gel containing bodily fluids would

leak out of the bag during long term storage and transportation. The spill would result in unsanitary conditions and likely lead to the product having no commercial success.

Def.'s Resp. to Pl.'s Br. 9-10.

The Court's Construction

The question under § 112, ¶ 6 “is not what structures a person of ordinary skill in the art would know are capable of performing a given function, but what structures are specifically disclosed and tied to that function in the specification.” Saffran v. Johnson & Johnson, 712 F.3d 549, 563 (Fed. Cir. 2013); accord Blackboard, Inc. v. Desire2Learn Inc., 574 F.3d 1371, 1385 (Fed. Cir. 2009). Plaintiff contends that the closure means is unimportant to the '139 Patent, and urges the Court to broadly construe the described closure mechanism to include “all closure means known in the art.” Pl.'s Br. 13-14. However, Defendant is correct that the only closure methods referenced in the specification of the '139 Patent are “a clamp 34,” and “a snap-and-seal zipper closure structure 43.” '139 Patent, Def.'s Br., Ex. 1 at A7, col. 4, l. 65, to A8, col. 5, ll. 26-27.

Defendant is also correct that the statute limits means-plus-function claims to “equivalents” of “the corresponding structure, material, or acts described in the specification.” 35 U.S.C. § 112, ¶ 6. What constitutes “equivalents thereof” varies depending upon the context. “[W]hen . . . the disclosed physical structure is of little or no importance to the claimed invention, there may be a broader range of equivalent structures than if the physical characteristics of the structure are critical in performing the claimed function in the context of the claimed invention.” IMS Tech., 206 F.3d at 1436.

Ultimately, the issue of whether a structure is an equivalent is a question of fact which should be resolved in later proceedings. Odetics, Inc. v. Storage Tech. Corp., 185 F.3d 1259, 1268-69 (Fed. Cir. 1999); Hartness Int'l, Inc. v. Simplimatic Eng'g Co., 819 F.2d 1100, 1110 (Fed. Cir. 1987); Trinity Indus. v. Road Sys., Inc., 121 F. Supp. 2d 1028, 1047 (E.D. Tex. 2000) (“Evaluation of the equivalency of the accused limitations is outside the scope of claim construction because it determines infringement and is therefore a question of fact.”).

For the above reasons, the Court construes the claim language as follows:

The language in Independent claim 1 that reads “closure means for closing the top of said bag” should be interpreted to mean a clamp 34 or zipper closure 43, and equivalents thereof.

Dependent Claims 5, 6, and 7

The parties have requested that this Court construe language in dependent claims 5, 6 and 7 referring to mesh sizes in the U.S. Sieve Series. The specific phrases at issue are “particle sizes in the range of -40+120 mesh U.S. Sieve Series,” and “particle sizes in the range of -40+80 mesh U.S. Sieve Series.” Given the similarities, these phrases are addressed together:

“Particle Sizes in the Range of -40+120 Mesh U.S. Sieve Series”

The complete dependent claims 5 and 6, with the language at issue highlighted, read:

5. A containment bag as in claim 4 wherein said hydrophilic material is in a powdered or granular form and has at least about 80% with particle sizes in the range of **-40+120 mesh U.S. Sieve Series**.

6. A containment bag as in claim 5 wherein said hydrophilic material has about 80%-90% with particle sizes in the range of **-40+120 mesh U.S. Sieve Series**.

'139 Patent, Def.'s Br., Ex. 1 at A10, col. 9, ll. 10-16.

“Particle Sizes in the Range of -40+80 Mesh U.S. Sieve Series”

The complete dependent claim 7, with the language at issue highlighted, reads:

7. A containment bag as in claim 6 wherein said hydrophilic material also has at least about 50% with particle sizes in the range of **-40+80 mesh U.S. Sieve Series**.

'139 Patent, Def.'s Br., Ex. 1 at A10, col. 9, ll. 17-20.

The parties request the following constructions:

Patent Language	Plaintiff's Proposed Construction	Defendant's Proposed Construction
Dependent claims 5 and 6: “particle sizes in the range of -40+120 mesh U.S. Sieve Series” '139 Patent, Def. Ex. 1 at A10, col. 9, ll. 12-13 and 15-16.	“Defendant submits that ‘particle sizes in the range of -40+120 mesh U.S. Sieve Series’ found in Claims 5 and 6, means 125 to 420 microns. Plaintiff will agree with this interpretation.” Pl.'s Br. 15.	“Indefinite under 35 U.S.C. § 112[, ¶ 2]. In the alternative: Particles ranging in size from 125 microns to 425 microns.” Def.'s Br. 35.

Patent Language	Plaintiff's Proposed Construction	Defendant's Proposed Construction
<p>Dependent claim 7: “particle sizes in the range of -40+80 mesh U.S. Sieve Series”</p> <p>'139 Patent, Def. Ex. 1 at A10, col. 9, ll. 19-20.</p>	<p>“Defendant submits that ‘particle sizes in the range of -40+80 mesh U.S. Sieve Series found in Claim 7 should be interpreted to mean: <i>Particles ranging in size from 177 microns to 420 microns.</i> Plaintiff will agree with this interpretation.”</p> <p>Pl.'s Br. 15-16.</p>	<p>“Indefinite under 35 U.S.C. § 112[, ¶ 2]. In the alternative: Particles ranging in size from 180 microns to 425 microns.”</p> <p>Def.'s Br. 35.</p>

Defendant argues that dependent claims 5, 6 and 7 are indefinite and cannot be construed, stating:

One of ordinary skill reading this patent would be torn between interpreting the claim limitations in terms of the U.S. Sieve Series values without any resort to the specification, or reading the parenthetical values in the specification as controlling. This, as noted below, is an ambiguity that is not resolvable.

Claims 5, 6 and 7 are indefinite and cannot be construed. “A determination that a patent claim is invalid for failure to meet the definiteness requirement of 35 U.S.C. § 112, ¶ 2 is a conclusion that is drawn from the court's performance of its duty as the construer of patent claims . . .” *Bancorp Services, L.L.C. v. Hartford Life Ins. Co.*, 359 F.3d 1367, 1371 (Fed. Cir. 2004) (citation and quotation omitted); *Atmel Corp. v. Info. Storage Devices, Inc.*, 198 F.3d 1374, 1378 (Fed. Cir. 1999).

Def.'s Resp. to Pl.'s Br. 16.

Alternatively, based on the ASTM standard, Defendant notes:

“A technical term in a patent document has the meaning that it would be understood to have by persons knowledgeable in the field of the invention and the prior art.” *Norian Corp. v. Stryker Corp.*, 363 F.3d 1321, 1326 (Fed. Cir. 2004). A person of ordinary skill would understand that U.S. Sieve Series is a unit of measurement and would have the knowledge to use the American Society for Testing and Materials (ASTM) standardization when converting from U.S. Sieve Series to microns.

Id. at 17.

On the subject of indefiniteness, Plaintiff states only:

It is not apparent from defendant's brief how the claims are now "indefinite." If there is any significant difference between sieve measurements and micron measurements, the finding of a significant difference would be an issue of fact to be resolved at trial.

Pl.'s Claim Construction Reply Br. 7.

The Court's Construction

The parties were nearly in agreement on a construction for the U.S. Sieve Series references, separated by "rather minute differences." Def.'s Br. 36-37. Muddling this potential agreement, however, Defendant now claims the language is indefinite and cannot be construed.

A maxim of patent law is that claims should be construed to preserve their validity. Phillips, 415 F.3d at 1327-28. Patents have a presumption of validity under 35 U.S.C. § 282, and the Supreme Court, citing Federal Circuit law, has decreed that "a defendant seeking to overcome this presumption must persuade the fact finder of its invalidity defense by clear and convincing evidence." Microsoft Corp. v. i4i Ltd. P'ship, 131 S. Ct. 2238, 2242-43 (2011) (citing Am. Hoist & Derrick Co. v. Sowa & Sons, Inc., 725 F.2d 1350, 1359-60 (Fed. Cir. 1984)), abrogated on other grounds by Therasense, Inc. v. Becton, Dickinson & Co., 649 F.3d 1276 (Fed. Cir. 2011) (en banc). "The primary purpose of the definiteness requirement is to ensure that the claims are written in such a way that they give notice to the public of the extent of the legal protection afforded by the patent, so that interested members of the public, *e.g.*, competitors of the patent owner, can determine whether or not they infringe." All Dental Prodx, LLC v. Advantage Dental Prods., Inc., 309 F.3d 774, 779-80 (Fed. Cir. 2002) (citing Werner-Jenkinson Co. v. Hilton Davis Chem. Co., 520 U.S. 17, 28-29 (1997)).

The question of validity and definiteness are inexorably linked under 35 U.S.C. § 112, ¶ 2. In order to be valid, a patent claim must "particularly point[] out and distinctly claim[] the subject matter which the applicant regards as his invention." 35 U.S.C. § 112, ¶ 2. The purpose of the definiteness requirement under 35 U.S.C. § 112, ¶ 2 is "to ensure that the claims delineate the scope of the invention using language that adequately notifies the public of the patentee's right to exclude." Datamize, LLC v. Plumtree Software, Inc., 417 F.3d 1342, 1347 (Fed. Cir. 2005). Patent claims are indefinite when they are not "amenable to construction," or are "insolubly ambiguous." Exxon Research & Eng'g Co. v. United States, 265 F.3d 1371, 1375 (Fed. Cir. 2001).

The intrinsic evidence does not support a finding that these claims are indefinite. The language of the '139 Patent clearly identifies particle sizes in terms of -40+120 mesh and -40+80 mesh U.S. Sieve Series in both the claims and the specification. The U.S. Sieve Series is a sufficiently definite standard, a reference that gives notice to the public of the extent of the legal protection afforded by the patent. All Dental Prodx, 309 F.3d at 779. Here, it is well established that "a defendant raising an invalidity defense [bears] 'a heavy burden of persuasion,' requiring proof of the defense by clear and convincing evidence." Microsoft Corp., 131 St. Ct. at 2246

(quoting Radio Corp. of Am. v. Radio Eng'g Labs, 293 U.S 1, 8 (1934)). Defendant has failed to marshal clear and convincing proof to establish indefiniteness, a point which Defendant appears to concede stating “there really isn’t a clear answer as to whether . . . this is, you know, bad enough to be insolubly ambiguous or not.” Tr. 113.

In light of the claims’ clear references and the parties’ positions, the claim language in dependent claims 5, 6 and 7 needs no construction and shall remain as written in the claims, i.e., “particle sizes in the range of -40+120 mesh U.S. Sieve Series,” and “particle sizes in the range of -40+80 mesh U.S. Sieve Series.” A person of ordinary skill in the art would have the knowledge to convert the U.S. Sieve Series to microns.

Conclusion

For the above reasons, the Court construes the claims as follows:

1. The language in Independent claim 1 that reads “said open bottom being free from attachment to said sides of said bag,” should be interpreted to cover any containment bag where the open bottom of the funnel is free from attachment to said sides, but is not necessarily free from attachment to the edges.

2. The language in Independent claim 1 that reads “unsequestered fluid,” should be interpreted to mean water or water-based liquids such as bodily fluids, containing some hydrophilic material, that have not yet gelled.

3. The language in Independent claim 1 that reads “closure means for closing the top of said bag” should be interpreted to mean a clamp 34 or zipper closure 43, and equivalents thereof.

4. Dependent claims 5, 6 and 7 are not indefinite, and they require no construction.

Counsel for the parties shall file a joint status report on or before **June 7, 2013**, proposing a schedule for further proceedings.

/s/ Mary Ellen Coster Williams
MARY ELLEN COSTER WILLIAMS
Judge