

**E
X
H
I
B
I
T**

36



US005502839A

United States Patent [19]

[11] Patent Number: **5,502,839**

Kolnick

[45] Date of Patent: **Mar. 26, 1996**

[54] **OBJECT-ORIENTED SOFTWARE ARCHITECTURE SUPPORTING INPUT/OUTPUT DEVICE INDEPENDENCE**

[75] Inventor: **Frank C. Kolnick, Willowdale, Canada**

[73] Assignee: **Motorola, Inc., Schaumburg, Ill.**

[21] Appl. No.: **361,738**

[22] Filed: **Jun. 2, 1989**

Related U.S. Application Data

[63] Continuation of Ser. No. 619, Jan. 5, 1987, abandoned.

[51] Int. Cl.⁶ **G06F 13/00**

[52] U.S. Cl. **395/800; 364/228.2; 364/237.9; 364/239.9; 364/280; 364/284.2; 364/DIG. 1**

[58] Field of Search **364/200 MS File, 364/900 MS File; 395/500**

[56] References Cited

U.S. PATENT DOCUMENTS

3,930,232	12/1975	Wallach et al.	395/500
4,241,341	12/1980	Thorson	340/747
4,454,593	6/1984	Fleming	364/900

4,485,439	11/1984	Rothstein	395/500
4,547,628	10/1985	Tamura et al.	340/747
4,555,775	11/1985	Pike	364/900
4,559,614	12/1985	Peek et al.	364/900
4,642,790	2/1987	Minshull et al.	364/900
4,754,395	6/1988	Weisshaar et al.	364/200
4,800,523	1/1989	Gerety et al.	395/500
4,858,114	8/1989	Heath et al.	395/500
5,063,494	11/1991	Davidowski et al.	395/800

Primary Examiner—Kevin J. Teska
Assistant Examiner—Ayni Mohamed
Attorney, Agent, or Firm—Walter W. Nielsen; Harold C. McGurk; S. Kevin Pickens

[57] ABSTRACT

An object-oriented software architecture interacts with "real" input/output devices exclusively through "virtual" input/output devices. Since all human interface with the operating system is performed through such virtual devices, the system can accept any form of real input or output devices. The lowest level of the operating system converts input from any physical device to virtual form and converts virtual output into suitable physical output. Any number of physical devices can be connected to, removed from, or replaced in the system without disrupting the system.

23 Claims, 9 Drawing Sheets

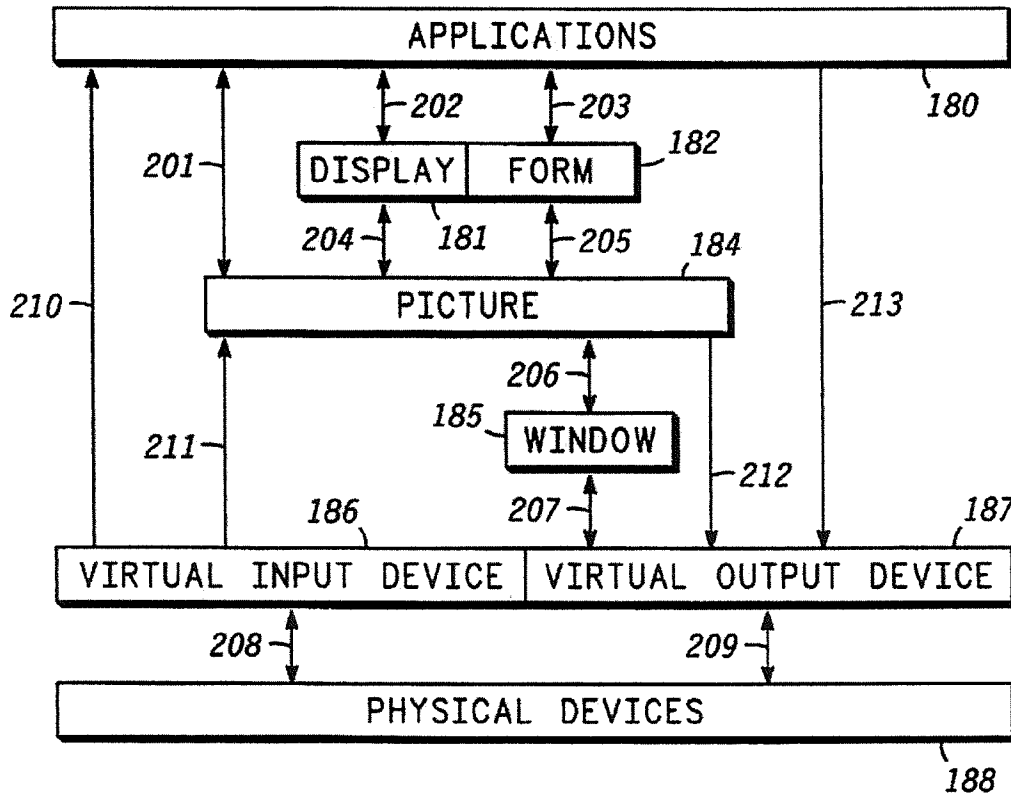

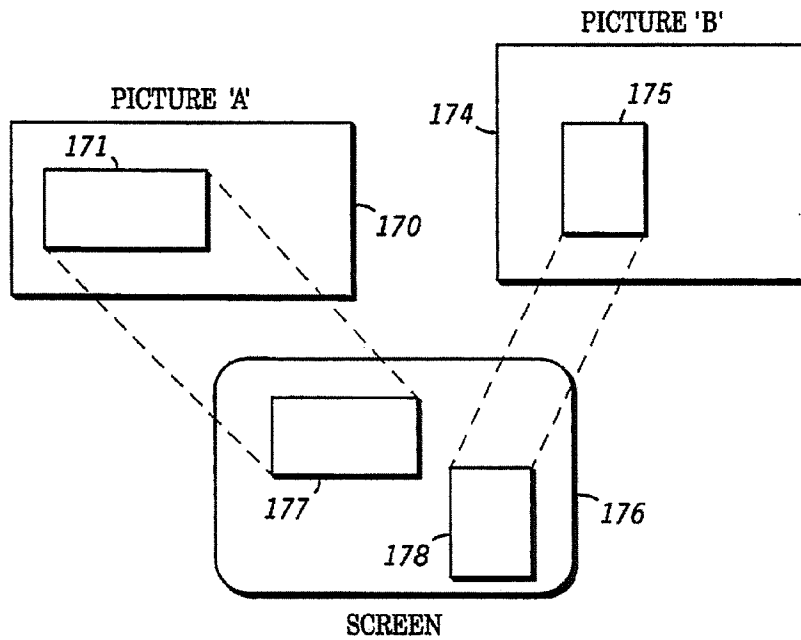
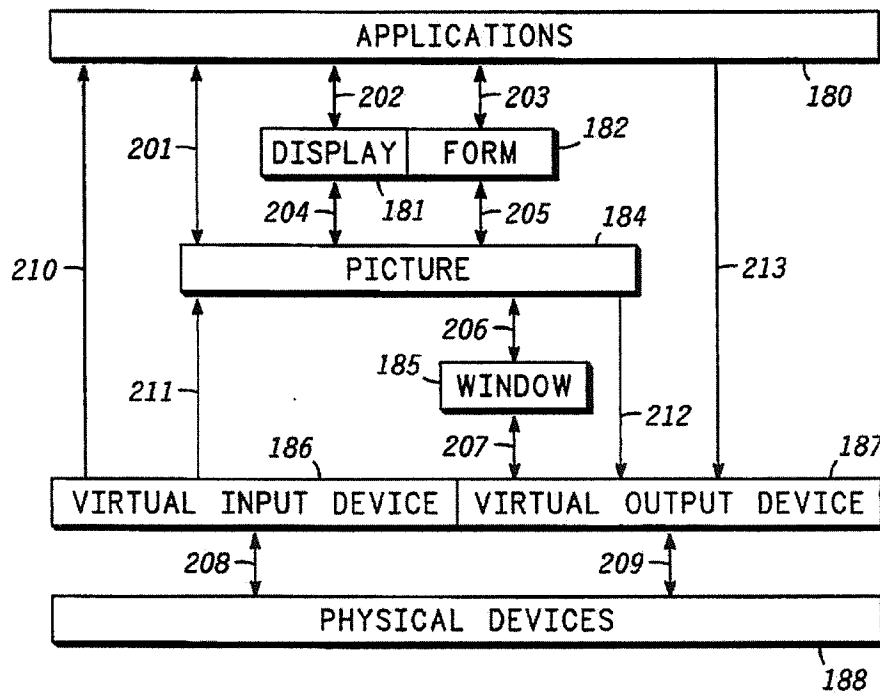

FIG. 7

FIG. 8



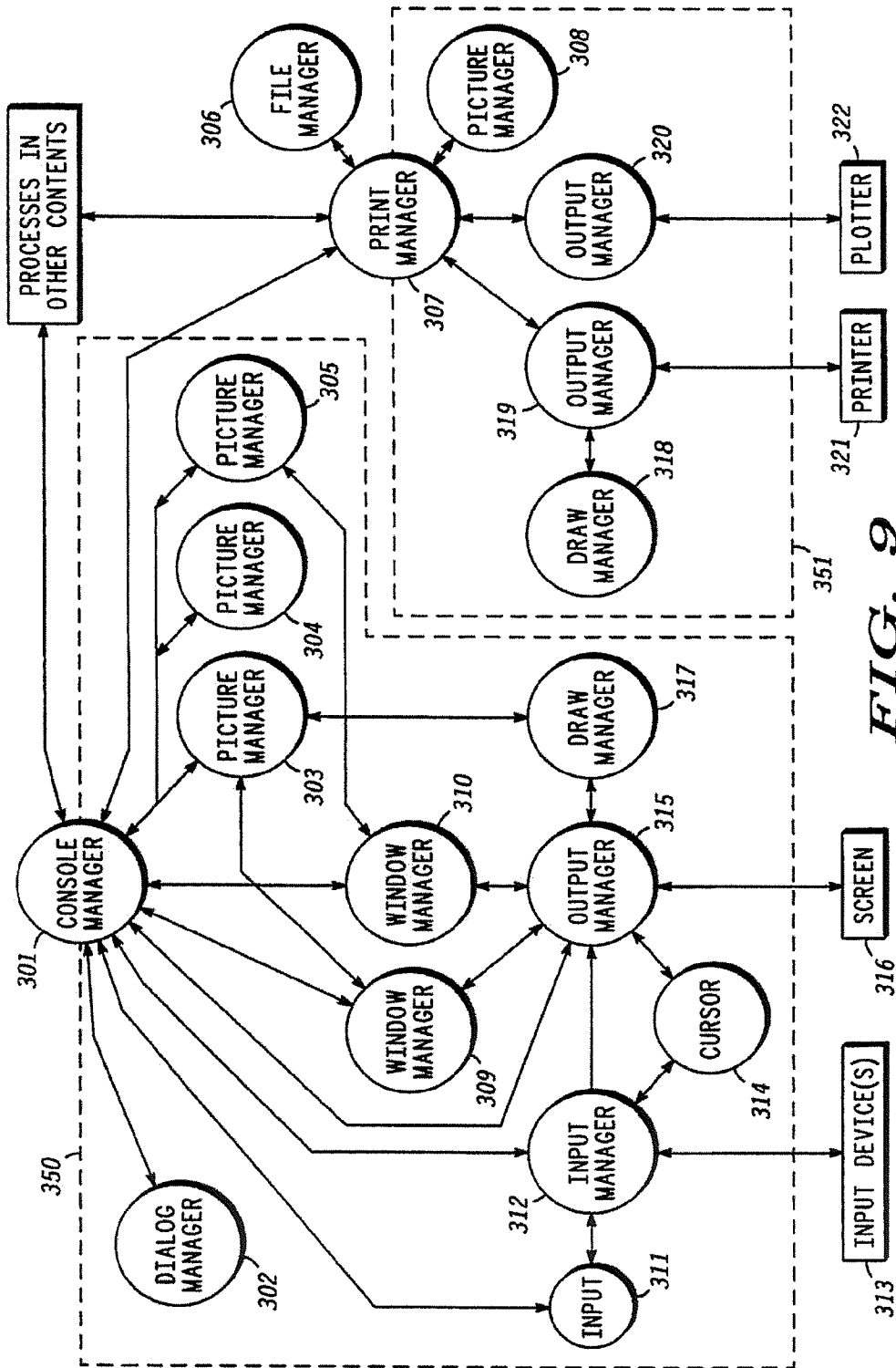

FIG. 9

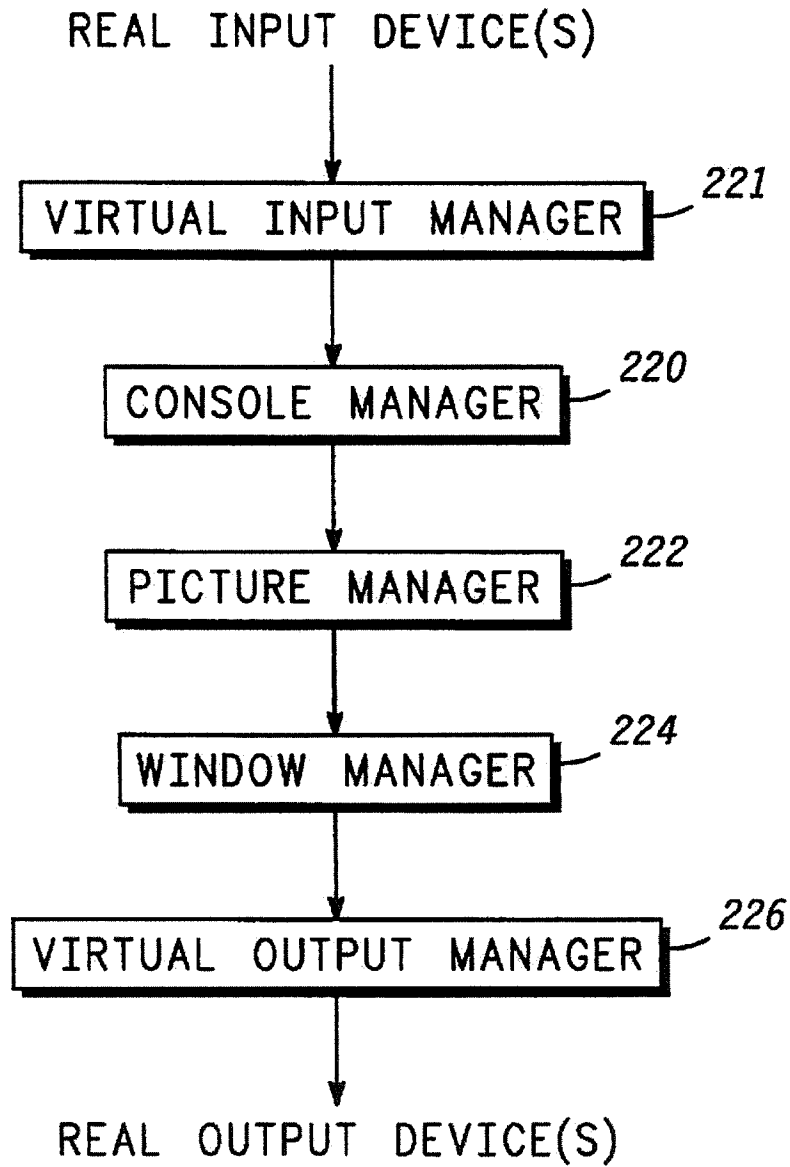

FIG. 12

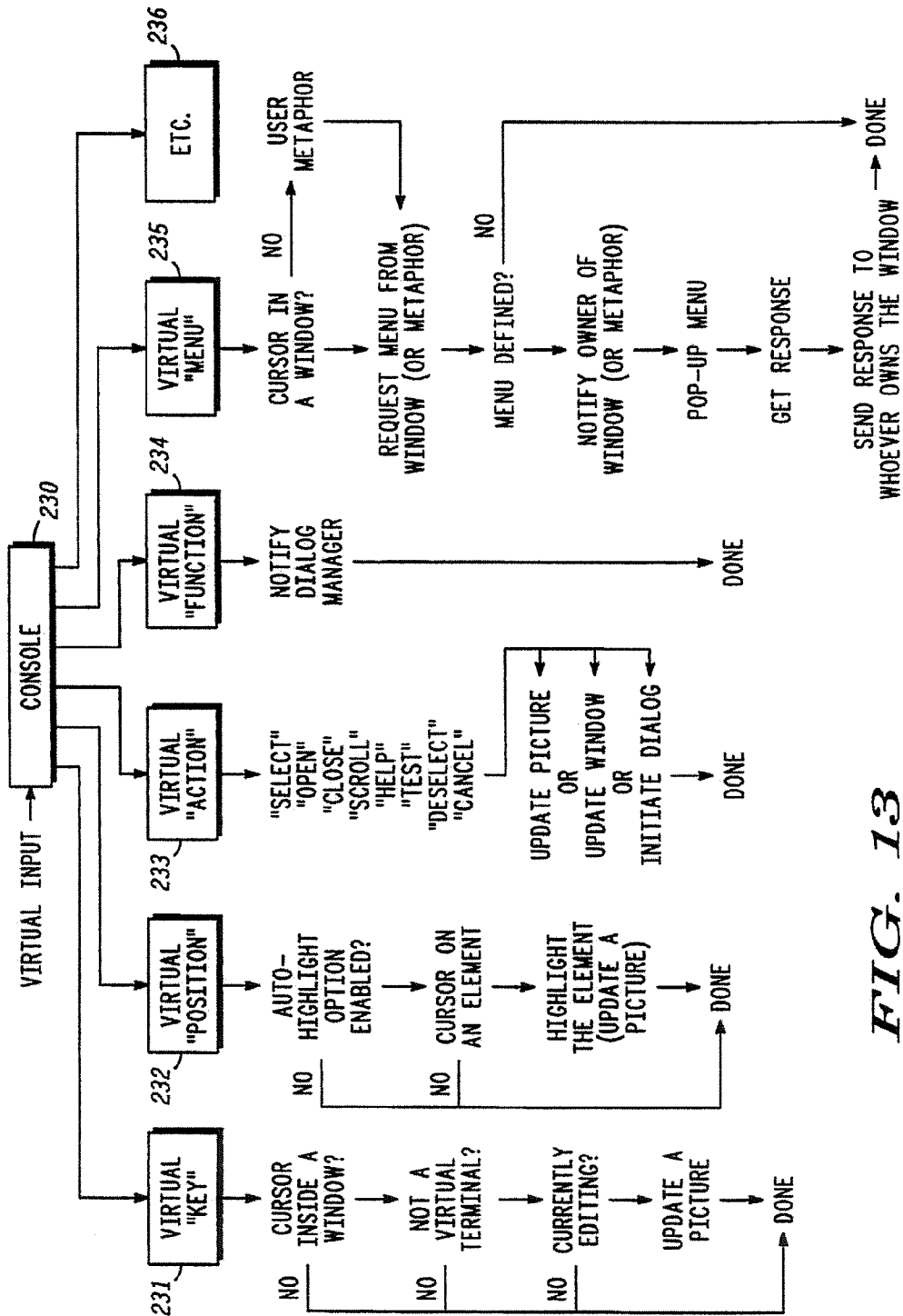

FIG. 13

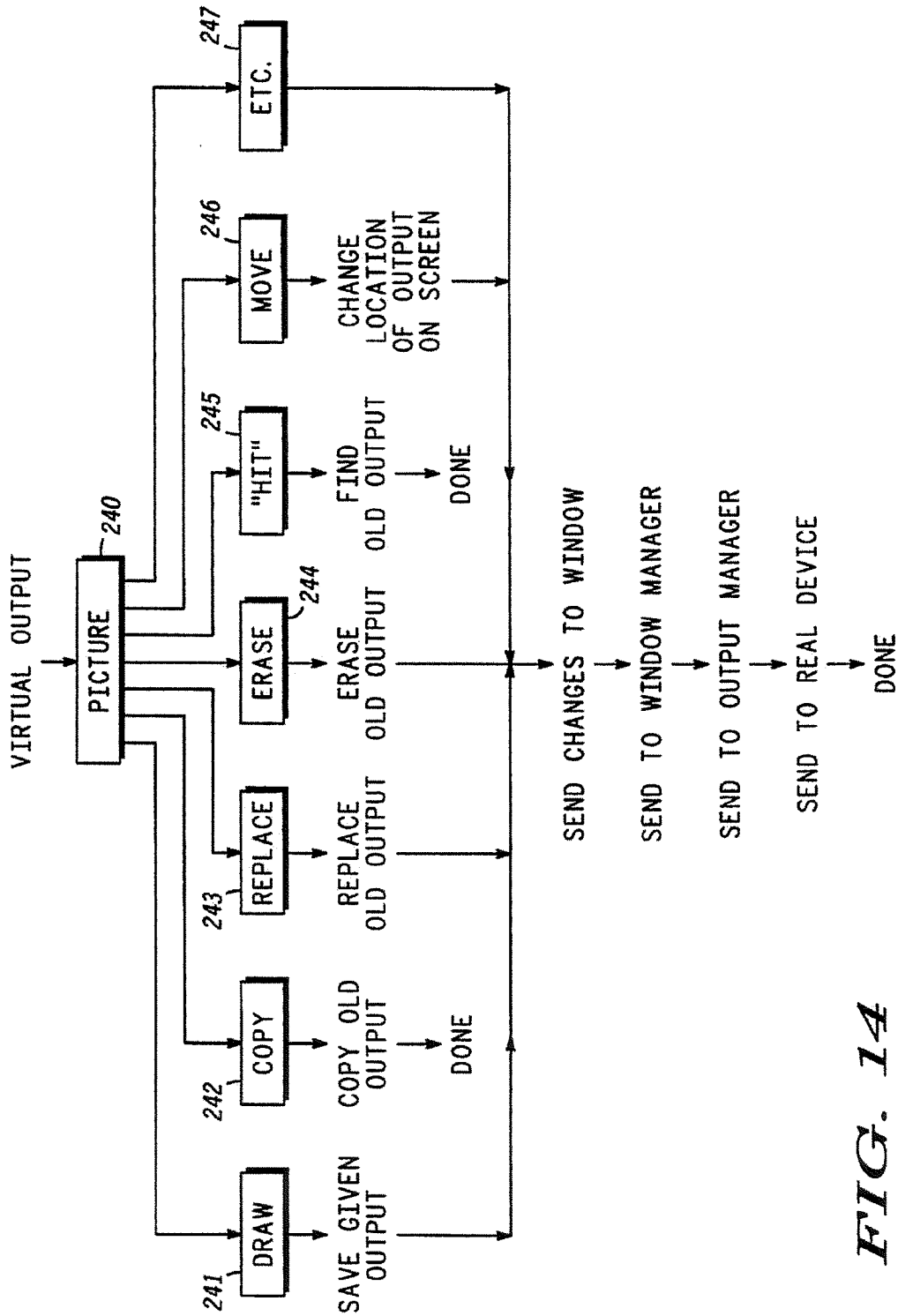

FIG. 14

The Human Interface builds on the above concepts to provide a set of distributed services. These include electronic mail, which allows two or more users at different terminals to communicate with each other in real time or to queue files for later delivery, and a forms manager for data entry. A subclass of windows called "virtual terminals" provides emulation of standard commercially available terminals.

FIG. 8 shows the different levels of the Human Interface and data flow through them. Arrows 201-209 indicate the most common paths, while arrows 210-213 indicate additional paths. The interface can be configured to leave out unneeded layers for customized applications. The philosophy behind the Human Interface design dictates one process per object. That is, a process is created for each active window, picture, input or output device, etc. As a result, the processes are simplified and can be distributed across nodes almost arbitrarily.

MULTIPLE INDEPENDENT PICTURES AND WINDOWS

A picture is not associated with any particular device, and it is of virtually unlimited size. A "window" is used to extract a specified rectangular area—called a "view"—of picture information from a picture and pass this data to a virtual output manager.

The pictures are completely independent of each other. That is, none is aware of the existence of any other, and any picture can be updated without reference to, and without affect upon, any other. The same is true of windows.

Thus the visual entity seen on the screen is really represented by two objects: a window (distinguished by its frame title, scroll bars, etc.), and a picture, which is (partially) visible within the boundaries of the window's frame.

As a consequence of this autonomy, multiple pictures can be updated simultaneously, and windows can be moved around on the screen and their sizes changed without the involvement of other windows and/or pictures.

Also, such operations are done without the involvement of the application which is updating the window. For example, if the size of a window is increased to look at a larger area of the picture, this is handled completely within the human interface.

HUMAN INTERFACE—PRIMARY FEATURES

The purpose of the Human Interface is to transform machine-readable data into human-readable data and vice versa. In so doing the Human Interface provides a number of key services which have been integrated to allow users to interact with the system in a natural and consistent manner. These features will now be discussed.

Device Independence—The Human Interface treats all devices (screens, printers, etc.) as "virtual devices" None of the text, graphics, etc. in the system are tied to any particular hardware configuration. As a result such representations can be entered from any "input" device and displayed on any "output" device without modification. The details of particular hardware idiosyncracies are hidden in low-level device managers, all of which have the same interface to the Human Interface software.

Picture Drawing—The Human Interface can draw "pictures" composed of any number of geometric elements, such as lines, circles, rectangles, etc., as well as any arbitrary shape defined by the user. Each element can have its own

color and line thickness. In addition, closed figures may be filled in with a particular shading pattern in any given color. A picture can be of almost any size. All output from the Human Interface to a user is via pictures, and all input from a user to the Human Interface is stored as pictures, so that there is only one representation of data within the Human Interface.

Text can be freely intermixed with graphical images, so that the user need only learn one "editor" to do his job. Consequently it is not necessary to switch between editors or "cut and paste" between pictures. Text characters can be selected from a large predefined character set, which includes mathematical and Greek symbols, among others, and can be typed in a wide variety of fonts, colors, sizes, and styles (e.g. bold, italic, or underlined). It is also possible for a user to define his own symbols and add them to the character set.

Windowing—The Human Interface allows the user to partition a screen into as many "sub-screens" or "windows" as required to view the information he desires. The Human Interface places no restrictions on the contents of such windows, and all windows can be simultaneously updated in real time with data from any number of concurrently executing programs. Any picture can be displayed, created, or modified ("edited") in any window. Also any window can be expanded or contracted, or it can be moved to a new location on the screen at any time.

If the current picture is larger than the current window, the window can be scrolled over the picture, usually in increments of a "line" or a "page". It is also possible to temporarily expand or contract the visible portion of the picture ("zoom in" or "zoom out") without changing the window's dimensions and without changing the actual picture.

Dialog Management—The Human Interface is independent of any particular language or visual representation. That is, there are no built-in titles, menus, error messages, help text, icons, etc. for interacting with the system. All such information is stored as pictures which can be modified to suit the end user's requirements, either prior to or after installation. The user can modify the supplied dialog with his own at any time.

Data Entry—The Human Interface provides a generalized interface between the user and any program (such as a data base manager) which requires data from the user. The service is called "forms management", because a given data structure is displayed as a fill-in-the-blanks type of "form" consisting of numerous modifiable fields with descriptive labels. The Human Interface form is interactive, so that data can be verified as it is entered, and the system can assist the user by displaying explanatory text when appropriate (on demand or as a result of an error).

Communication Between Users—The Human Interface permits two or more users to "converse" with each other in real time or to send "mail" to each other. Conversation is performed through a window on each of the user's screens. Mail is sent by creating a picture (text and/or diagrams) and specifying a destination. The destination may be one particular user, a group of users, or all users in the system (i.e. a "broadcast"). Transmission may be immediate or delayed until a given date and time or until the given user(s) sign onto the system. When mail arrives at the destination, the receiving user is informed and may then read, save, print, or erase the picture.

Event Management—The Human Interface can record any arbitrary event for future reference. The Human Interface defines a simple, yet flexible grammar for forming

"sentences" which describe events and which the Human Interface can use to parse in order to manipulate events for specific requests. For example, events can be dynamically displayed on a screen by time and/or priority, or they can be scanned for a particular "subject" or "object" or any other attribute. Each event can be time-stamped by the sender; if not, it is automatically time-stamped upon receipt.

The Human Interface records all of its own actions, such as printing a report or signing-on a user, and it provides this service to any applications program. In addition, the Human Interface can be requested to trigger any given action upon the occurrence of any given event, thus providing a kind of closed-loop control service to applications.

Modularity—The Human Interface comprises a number of separate software components which can be replicated and distributed throughout the hardware configuration to achieve optimal performance. For example, each time a new "console" (for example, keyboard plus screen) is connected to the system, a new "Console" component is created to manage it. There is no logical limit to the number of consoles that the Human Interface can handle. In general the relevant software component is located close to the hardware or other resources on which it most depends.

HUMAN INTERFACE—BASIC COMPONENTS

The Human interface comprises the following basic components:

Console Manager—It is the central component of a Console context and consequently is the only manager which knows all about its particular "console." It is therefore aware of all screens and keyboards, all windows, and all pictures. Its primary responsibility is to coordinate the activities of the context. This consists of starting up the console (initializing the device managers, etc.) creating and destroying pictures, and allocating and controlling windows for processes in the Human Interface and elsewhere. Thus all access to a console must be indirect, through the relevant Console Manager.

The Console Manager also implements the first level of Human Interface interaction, via menus, prompts, etc., so that applications processes don't have to. Rather than using built-in text and icons, it depends upon the Dialog Manager to provide it with the visible features of the system. Thus all cultural and user idiosyncracies (such as language) are hidden from the rest of the Human Interface.

A Console Manager knows about the following processes: the Output Manager(s) in its context, the Input Manager in its context, the Window Managers in its context, the Picture Managers in its context, and the Dialog Manager in its context. The following processes know about the Console Manager: any one that wants to.

When a Console Manager is started, it waits for the basic processes needed to communicate with the user to start up and "sign on". It is successful, it is ready to talk to users and other processes (i.e., accept messages from the Input Manager and other processes). All other permanent processes in the context (Dialog, etc.) are assumed to be activated by the system start-up procedure. The "In" and "Cursor" processes (see "Input Manager" and "Output Manager" below) are created by the Console Manager at this time.

The Console Manager generally clears the entire screen and displays appropriate status text during the course of the start-up (by sending picture elements directly to its Output

Manager(s)). If any part of the start-up fails, it displays appropriate "error" text and possibly waits for corrective action from a user.

The Console Manager views the screen as being composed of blank (unused) space, windows, and icons. Whenever an input character is received, the Console Manager determines how to handle it depending upon the location of the cursor and the type of input, as follows:

A. Requests to create or eliminate a window are handled within the Console Manager. A window may be opened anywhere on the screen, even on top of another window. A new Picture Manager and possibly a Window Manager may be created as a result, and one or more new messages may be generated and sent to them, or the manager(s) may be told to quit.

B. Icons can only be selected, then moved or opened. The Console Manager handles selection and movement directly. It sends notification of an "open" to the Dialog Manager, which sends a notification to the application process associated with the icon and possibly opens a default window for it.

C. For window-dependent actions, if the cursor is outside all windows, the input is illegal, and the Console Manager informs the user; otherwise the input is accepted. Request which affect the window itself (such as "scroll" or "zoom") are handled directly by the Console Manager. A "select" request is pre-checked, the relevant picture elements are selected (by sending a message to the relevant Picture Manager), and the message is passed on to the process currently responsible for the window. All other inputs are passed directly to the responsible process without being pre-checked.

If the cursor is on a window's frame, the only valid actions are to move, close, or change the dimensions of the window, or select an object in the frame (such as a menu or a scroll bar). These are handled directly by the Console Manager.

D. Requests for Human interface services not in the Console context are treated as errors.

A new window is opened by creating a new Window Manager process and telling it its dimensions and the location of its upper left corner on the screen. It must also be given the PID of a Picture Manager and the coordinates of the part of the picture it is to display, along with the dimensions of a "clipping polygon", if that information is available. (It is not possible to create a window without a picture.) The type and contents of the window frame are also specified. Any of these parameters may be changed at any time.

A new instance of a picture is created by creating a new Picture Manager process with the appropriate name and, optionally, telling it the name of a "file" from which to get its picture elements. If a file is not provided, an "empty" picture is created, with the expectation that picture-drawing requests will fill it in.

Menus, prompts, help messages, error text, and icons are simply predefined pictures (provided through the Dialog Manager) which the Console Manager uses to interact with users. They can therefore be created and edited to meet the requirements of any particular system the same way any picture can be created and edited. Menus and help text are usually displayed on request, although they may sometimes be a result of another operation.

Prompts are displayed when the system needs information from the user. Error text is displayed whenever the user tries to do something that is illegal or when the system is having

problems of its own (e.g. "printer out of paper"). Icons are displayed by the Console Manager automatically when a specific frame of reference is requested by the user. The Console Manager may also display informational messages (such as "console starting up") which are automatically 5 erased when the associated action is finished.

Picture Manager—It is created when a picture is built, and it exists when the picture is no longer required. There is one Picture Manager per picture. The Picture Manager constructs a device-independent representation of a picture 10 using a small set of elemental "picture elements" and controls modification and retrieval of the elements.

A Picture Manager knows about the following processes: the process which created it, and the Draw Manager. The following processes know about the Picture Manager: the 15 Console Manager in the same context, and Window Managers in the same context.

A Picture Manager is created to handle exactly one picture, and it need only be created when that picture is being accessed. It can be told to quit at any time, deleting its 20 representation of the picture. Some other process must copy the picture to a file if it needs to be saved.

When a Picture Manager first starts up, its internal picture is empty. It must receive a "load file" request, or a series of 25 "draw" requests, before a picture is actually available. Until that is done any requests which refer to specific elements or locations in the picture will receive an appropriate "not found" status message.

A picture is logically composed of device-independent "elements", such as text, line, arc, and symbol. In general, 30 there is a small number of such elements. Each element consists of a common header, which includes the element's position in the picture's coordinate system, its color, size, etc., and a "value" which is unique to the element's type (e.g. a character string, etc.). The header also specifies how 35 the element combines with other elements in the picture (overlays them, merges with them, etc.). A special element type called "null" is also supported to facilitate the removal of picture elements from pictures or other similar large lists without forcing time-consuming compaction procedures. 40 Any element can therefore be redefined to "null", indicating that it should be ignored for all future processing.

The "null" color (zero) is treated as transparent when used in either the foreground or the background. Specifically, if 45 the foreground color is null, the element itself is not drawn, but it may still be filled in. If the background color is null, the element is not filled in. If the shading pattern is null, and the color is not null, the background fill is solid.

A picture is represented in an internal format which may be different from the external representation of picture 50 elements and which is, in any case, hidden from other processes. This representation is designed to optimize retrieval of picture elements, with a secondary emphasis on adding new elements and modifying or erasing old ones. The order in which the elements were originally drawn is preserved 55 (unless explicit "order" requests have been received to re-arrange them).

Requests to "animate" an element result in the creation of a separate, local "animate" process which performs the 60 necessary transformations and sends the appropriate requests (usually "draw" or "erase") back to the Picture Manager periodically.

A Picture Manager processes incoming requests one at a time, as it receives them. Each message can change the state 65 of the picture for later requests. The Picture Manager supports numerous operations, including the following: "draw" new elements; "modify", "overwrite", or "erase"

existing elements; "copy" or "move" elements to another location in the same picture or to any other given process; "group" elements together into one (or "ungroup" them); "scale" them (i.e. expand, stretch, or shrink them); and 5 "rotate" them. It can also be asked to "notify" a particular process if any elements within a given rectangular area (the "viewport") are changed and to determine whether a given location coincides (or come close to) any element in the picture. Any response to a request (e.g., multiple picture elements) is sent in a single message.

When an element is sent as the result of an outstanding "notify" request, all elements which overlap it (and all 10 elements which overlap those elements) are sent as well. These are sent together in one message. The background is displayed by generating a "rectangle" element of the same size as the current viewport with a null foreground color and the appropriate background pattern and color. This element is always the lowest level in the picture; i.e., it is sent before 15 all others. All erasure of elements from a display is accomplished by "draw" requests which redisplay the background and/or elements in the picture, overwriting the "erased" elements. There is no explicit "erase" request to a window (or output) manager.

Input Manager—There is one Input Manager per set of 20 "logical input devices" (such as keyboards, mice, light pens, etc.) connected to the system. The Input Manager handles input interrupts and passes them to the console manager. Cursor movement inputs may also be sent to a designated output manager.

The Input Manager knows about the following processes: the process which initialized it, and possibly one particular 25 Output Manager in the same context. The following process knows about the Input Manager: the Console Manager in the same context.

An Input Manager is created (automatically, at system start-up) for each set of "logical input devices" in the 30 system, thus implementing a single "virtual keyboard". There can only be one such set, and therefore one Input Manager, per Console context. The software (message) interface to each manager is identical, although their internal behavior is dependent upon the physical device(s) to which 35 they communicate. All input devices interrupt service routines (including mouse, digitizing pad, etc.) are contained in Input Managers and hidden from other processes. When ready, each Input Manager must send an "I'm here" message to the closest process named "Console".

An Input Manager must be explicitly initialized and told to proceed before it can begin to process input interrupts. 40 Both of these are performed using appropriate messages. Whichever process initializes the manager becomes tightly coupled to it, i.e., they can exchange messages via PID's rather than by name. The Input Manager will send all inputs to this process (usually the Console Manager). This coupling cannot be changed dynamically; the manager would have to be re-initialized. Between the "initialize" and the "proceed" 45 an Input Manager may be sent one or more "set" requests to define its behavior. It does not need to be able to interpret the meaning of any input beyond distinguishing cursor from non-cursor. Device-independent parameters (such as pixel size and density) are not down-loaded but rather are assumed to be built into the software, some part of which, in general, must be unique to each type of Input Manager.

An Input Manager can be dynamically "linked" to a particular Output Manager, if desired. If so, all cursor control input (or any other given subset of the character set) 50 will be sent to that manager, in addition to the initializing process, as it is received. This assignment can be changed or

as "select key is being held down", "keyboard locked", etc. One input process is created by each Console Manager. The console's input message updates the process; any other process may query it.

The Human Interface is structured as a collection of subsystems, implemented as contexts, each of which is responsible for one broad area of the interface. There are two major contexts accessible from outside the Human Interface: "Console" and "Print" They handle all screen/keyboard interaction and all hard-copy output, respectively. These contexts are not necessarily unique. There may be one or more instances of each in the system, with possibly several on the same cell. Within each, there may be several levels of nested contexts.

The possible interaction between various Human Interface components will now be described.

Console Manager/Other Contexts—Processes of other contexts may send requests for console services or notification of relevant events directly to the Console Manager(s). The Console Manager routes messages to the appropriate service. It also notifies (via a "status" message) the current owner of a window whenever an object in its window has been selected. Similarly, it sends a message to an application when a user requests that application in a particular window.

Console Manager/Input Manager—The Console Manager initializes the Input Manager and usually assigns a particular Output Manager to it. The Input Manager always sends all input (one character, one key, one cursor movement, etc. at a time) directly to the Console Manager. It may also send "status" messages, either in response to a "download", "initialize", or "terminate" request, or any time an anomaly arises.

Console Manager/Output Manager—The Console Manager displays information on its "prime" output device during system start-up and shut-down without using pictures and windows. It therefore sends picture elements directly to an Output Manager. The Console Manager is also responsible for moving the cursor on the screen while the system is running, if applicable. The Console Manager (or any other Human Interface manager, such as an "editor") may change the current cursor to any displayable symbol. Output Managers will send "status" messages to the Console Manager any time an anomaly arises.

Console Manager/Picture Manager—The Console Manager creates Picture Managers on demand and tells each of them the name of a file which contains picture elements, if applicable. A Picture Manager can also accept requests from the Console Manager (or anyone else) to add elements to a picture individually, delete elements, copy them, move them, modify their attributes, or transform them. It can be queried for the value of an element at (or close to) a given location within its picture. The Console Manager will tell a Picture Manager to erase its picture and exit when it is no longer needed. A Picture Manager usually sends "status" messages to the Console Manager whenever anything unusual (e.g., an error) occurs.

Console Manager/Window Manager—The Console Manager creates Window Managers on demand. Each Window Manager is told its size, the PID of an Output Manager, the coordinates (on the screen) of its upper left outside corner, the characteristics of its frame, the PID of a particular Picture Manager, the coordinates of the first element from which to start displaying the picture, and the name of the process which "owns" the window. While a window is active, it can be requested to re-display the same picture starting at a different element or to display a completely different picture.

The coordinates of the window itself may be changed, causing it to move on the screen, or it may be told to change its size, frame, or owner. A Window Manager can be told to "clip" the picture elements in its display along the edges of a given polygon (the default polygon is the inside edge of the window's frame). It can also be queried for the element corresponding to a given coordinate. The Console Manager will tell a Window Manager to "close" (erase) its window and exit when it is no longer needed. A Window Manager sends "status" messages to the Console Manager to indicate success or failure of a request.

Console Manager/Dialog Manager—The Dialog Manager accepts requests to load and/or dynamically create "pictures" which represent menus, prompts, error messages, etc. In the case of interactive pictures (such as menus), it also interprets the response for the Console Manager. Other processes may also use the Dialog Manager through the Console Manager.

Console Manager/Prime Manager—Console Managers generally send "spool" requests to Print Managers to get hard-copies of screens or pictures. An active picture must first be copied to a file. The Print Manager returns a "status" message when the request is complete or if it fails.

Window Manager/Picture Manager—A Window Manager requests lists of one or more picture elements from the relevant Picture Manager, specified by the coordinates of a rectangular "viewport" in the picture. It can also request the Picture Manager to automatically send changes (new, modified, or erased elements), or just notification of changes, to it. The Picture Manager sends "status" messages to notify the Window Manager of changes or errors.

Window Manager/Output Manager—A Window Manager sends lists of picture elements to its Output Manager, prefixed by the coordinates of a polygon by which the Output Manager is to "clip" the pixels of the elements as it draws them. A given list of picture elements can also be scaled by a given factor in any of its dimensions. The Output Manager returns a "status" message when a request fails.

Input Manager/Output Manager—The Input Manager sends all cursor movement inputs to a pre-assigned Output Manager (if any), as well as to the Console Manager. This assignment can be changed dynamically.

Print Manager/Other Processes—The Print Manager accepts requests to "spool" a file or to "print" one or more picture elements. It sends a "status" message at the completion of the request or if the request cannot be carried out. The status of a queued request can also be queried or changed at any time.

Print Manager/File Manager—The Print Manager reads picture elements from a File Manager (whose name was sent to it via a "spool" request). It may send a request to "delete" the file back to the File Manager after it has finished printing the picture.

Print Manager/Picture Manager—A Print Manager creates a Picture Manager for each spooled picture that it is currently printing, giving it the name of the relevant file. It then requests "pages" of the picture (depending upon the characteristics of the output device) one at a time. Finally, it tells the Picture Manager to go away.

Print Manager/Output Manager—The Print Manager sends picture elements to an Output Manager. The Output Manager sends a "status" message when the request completes or fails or when an anomaly arises on the printer.

Draw Manager/Other Processes—The Draw Manager accepts lists of elements prefixed by explicit pixel param-

When used to create a new window resource, it may contain information about the resource type (i.e. a "window"); the path-name of the window; the window's title; the window's position on the screen; the size of the window; the color, width, fill color between the outline and the pane, and the style of the main window outline; the color and width of the pane outline; a mapping of part of a picture into the window; a modification notation; a special character notation; various options; a "when" parameter requesting notification of various specified actions on/within the window; a title bar; a palette bar; vertical and horizontal scroll bars; a general use bar; and a corner box.

When used to create a new virtual terminal, it may contain information about the resource type (i.e. a "terminal"); the path-name of the terminal; the title of the terminal's window; various options; the terminal's position on the screen; the size of the terminal (i.e. number of lines and columns in the window); the maximum height and width of the virtual screen; the color the text inside the window; tab information; emulator process information; connector information to an existing window; window frame color; a list of menu items; and alternative format information.

OPEN is used to connect to a Human Interface service or to an existing Human Interface resource. When used to connect to a Human Interface service, it may contain information about the service type; and the name of the particular instance of the service. This resource must be sent to the Human Interface context.

When used to connect to an existing Human Interface resource, it may contain information about the path-name of the resource; the type of resource (e.g. picture, window, or terminal); and the name of the file (for pictures only) from which to load the picture. This request can be sent to a Human Interface manager or a console manager; alternatively the same message with message I.D. "init" specifying a file can be sent directly to a privately owned picture manager.

DELETE is used to remove an existing Human Interface resource from the system, and it may contain information specifying a connection to the resource; the type of resource; and whether, for a window, the corresponding picture is to be deleted at the same time.

CLOSE is used to break a connection to a Human Interface resource, and it may contain information specifying a connection to the resource; and the type of resource.

WHO? is used to request a list of signed-on users, and it may contain a user identification string.

QUERY is used to get the status of a service or resource, and it may contain information about the resource type; the name of the service or resource; a connector to a resource; and information concerning various options.

The following are the various Console Responses and the types of information which may be associated with each:

CONNECT provides a connection to a Human Interface resource, and it contains information concerning the originator (i.e. the Human Interface or the console); the resource type; the original request message identifier; the name of the resource; and a connector to the resource.

USER contains the names of zero or more currently signed-on users and their locations, and it contains a connector to a console manager followed by the name of the user signed on at that console.

Console Requests

The main purpose of the console is to coordinate the activities of the windows, pictures, and dialog associated

with it. Any of the CREATE, OPEN, DELETE, and CLOSE connection requests listed above, except those relating to the consoles, can be sent directly to a known console manager, rather than to the Human Interface manager (which always searches for the console by name). Subsequently, some characteristics of a window, such as its size, can be changed dynamically through the console manager. The current "user" of the console can be changed. And the console can be queried for its current status (or that of any of its resources).

The following are the various Console Requests and the types of information which may be associated with each:

USER is used to change the currently signed-on user, and it contains a user identification string.

CHANGE is used to change the size and other conditions of a window, and it may contain information about a connector to a window or a terminal; new height and width (in virtual pixels); increment to height and width; row and column position; various options; a connector to a new owner process; and whether the window should be the current active window on the screen.

CURSOR is used to move the screen cursor, and it contains position information as to row and column.

QUERY is used to get the current status of the console or one of its resources, and it contains information in the form of a connector to the resource; and various query options (e.g. list all screens, all pictures, or all windows).

BAND starts/stops the rubber-banding function and dragging function, and it contains information about the position of a point in the picture from which to start the operation; the end point of the figure which is to be dragged; the type of operation (e.g. line, rectangle, circle, or ellipse); the color; and the type of line (e.g. solid). In rubber-banding the drawn figure changes in size as the cursor is moved. In dragging the figure moves with the cursor.

The following are the various Console Responses and the types of information which may be associated with each:

STATUS describes the current state of a console, and it may contain information about a connector to the console; the originator; the name of the console; current cursor position; current metaphor size; scale of virtual pixels per centimeter, vertically and horizontally; number of colors supported; current user i.d. string; screen size and name; window connector and name; and picture connector, screen name, and window name.

Picture-Drawing

The picture is the fundamental building block in the Human Interface. It consists of a list of zero or more "picture elements", each of which is a device-independent abstraction of a displayable object (line, text, etc.). Each currently active picture is stored and maintained by a separate picture manager. "Drawing" a picture consists of sending picture manipulation messages to the picture manager.

A picture manager must first be initialized by a CREATE or OPEN request (or INIT, if the picture was created privately). CREATE sets the picture to empty, gives it a name, and defines the background. The OPEN request reads a predefined picture from a file and gives it a name. Either must be sent first before anything else is done. A subsequent OPEN reloads the picture from the file.

The basic request is to WRITE one or more elements. WRITE adds new elements to the end of the current list, thus

reflecting the order. Whenever parts of the picture are copied or displayed, this order is preserved. Once drawn, one or more elements can be moved, erased, copied, or replaced. All or part of the picture can be saved to a given file. In addition, there are requests to quickly change a particular attribute of one or more elements (e.g. select them). Finally, the DELETE request (to the console manager; QUIT, if direct to the picture resource) terminates the picture manager, without saving the picture.

Any single element can be "marked" for later reference. If the element is text, then a particular offset in the string can be marked, and a visible mark symbol displayed at that location.

A picture can be shared among several processes ("applications") by setting the "appl" field in the picture elements. Each application process can treat the picture as if it contains only its own elements. All requests made by each process will only affect elements which contain a matching "appl" field. Participating processes must be identified to the picture manager via an "appl" request.

The following are the various Picture-Drawing Requests and the types of information which may be associated with each:

WRITE is used to add new elements to a picture, and it may contain information providing a list of picture elements; the data type; and an indication to add the new elements after the first element found in a given range (instead of the foreground, at the end of the list).

READ is used to copy elements from a picture, and it may contain information regarding the connection to which to send the elements; an indication to copy background elements; and a range of elements to be copied.

MOVE is used to move elements to another location, and it may contain information indicating a point in the picture to which the elements are to be moved; row and column offsets; to picture foreground; to picture background; fixed size increments; and a range of elements to be moved.

REPLACE is used to replace existing elements with new ones, and it may contain information providing a list of picture elements; and a range of elements to be replaced.

ERASE is used to remove elements from a picture, and it may contain information on the range of elements to be erased.

QUIT is used to erase all elements and terminate, and it has no particular parameters (valid only if the picture is private).

MARK is used to set a "marked" attribute (if text, to display a mark symbol), and it may contain information specifying the element to be marked; and the offset of the character after which to display the mark symbol.

SELECT is used to select an element and mark it, and it may contain information specifying the element(s) to be selected; the offset of the character after which to display the mark symbol; the number of characters to select; and a deselect option.

SAVE is used to copy all or part of a picture to a file, and it may contain information specifying the name of the file, and a subset of a picture.

QUERY is used to get the current status, and it has no particular parameters.

BKGD is used to change a picture's background color, and it may contain information specifying the color.

APPL is used to register a picture as an "application", and it may contain information specifying a name of the

application; a connection to the application process; and a point of origin inside the picture.

NUMBER is used to get ordinal numbers and identifiers of specific elements, and it may contain information specifying the element(s).

HIT is used to find an element at or closest to a given position, and it may contain a position location in a picture; and how far away from the position the element can be.

[] is used to start/end a batch, and a first symbol causes all updates to be postponed until a second symbol is received (batches may be nested up to 10 deep).

HIGHLIGHT, INVERT, BLINK, HIDE are used to change a specific element attribute, and they may contain information indicating whether the attribute is set or cleared; and a range of elements to be changed.

CHANGE is used to change one or more element fields, and it may contain information specifying the color of the element; the background color; the fill color; and fill pattern; and a range of elements to be changed.

EDIT is used to modify a text element's string, and it may contain information indicating to edit at the current mark and then move the mark; specifying the currently selected substring is to be edited; an offset into the text at which to insert and/or from which to start shifting; to shift the text by the given number of characters to/from the given position; tab spacing; a replacement substring; to blank to the end of the element; and a range of elements to be edited.

In general, when a range of elements is specified, a list of one or more parameters is provided (if omitted, then all elements in the picture are referenced by default) according to the following table:

Keyword	Meaning	Format
@pos	by position (start of range)	row, column
@end	last position of a range	row, column
@num	by relative element number	list of numbers
@tag	search for a tag	pattern
@txt	search for a text element	pattern
@sel	"selected" element(s)	keyword only
@mrk	"marked" element	keyword only
@id	by unique element identifier	list of identifiers
@att	by attributes	attribute structure
@cnt	the number of elements	count

Any range parameters which are given restrict the elements which will be affected by the current request. In general, only the intersection of all of the elements satisfying the given conditions are included in the range. For example, specifying pos, end, tag, txt, and sel together means "use all selected text elements between the given coordinates, containing a particular tag and an particular text string."

The following are the various Picture-Drawing responses and the types of information which may be associated with each:

STATUS describes the current status of the picture, and it may contain information specifying a connector to the picture; an original message identifier, if applicable; the name of the picture; the name of the file last read or written; height and width; lowest and highest row/column in the picture; the number of elements; and the number of currently active viewpoints.

WRITE contains elements copied from a picture, and it may contain information specifying a connector to the picture; a list of picture elements; and the data type.

NUMBER contains element numbers and identifiers, and it may contain information specifying a list of numbers; and a list of element identifiers.

Picture Elements

Picture elements are defined by a collection of data structures, comprising one for a common "header", some optional structures, and one for each of the possible element types. The position of an element is always given as a set of absolute coordinates relative to [0,0] in the picture. This defines the upper left corner of the "box" which encloses each element. Points specified within an element (e.g. to define points on a line) are always given as coordinates relative to this position. In a "macro" the starting position of each individual element is considered to be relative to the absolute starting position of the macro element itself, i.e. they're nested.

FIG. 10 shows the general structure of a complete picture element. The "value" part depends upon the element type. The "appl" and "tag" fields are optional, depending upon indicators set in "attr".

The following is a description of the various fields in a picture element:

Length=length of the entire picture element in bytes

Type=one of the following: text, line, rectangle, ellipse, circle, symbol, array, discrete, macro, null, meta-element

Attr=one of the following: selectable, selected, rectilinear, inverted foreground/background, blink, tagged, application mnemonic, hidden, editable, movable, copyable, erasable, transformed, highlighted, mapped/not mapped, marked, copy

Pos=Row/col coordinates of upper left corner of the element's box

Box=Height/width of an imaginary box which completely and exactly encloses the element

Color=color of the element, consisting of 3 sub-fields: hue, saturation, and value

Bkgnd=background color of the element

Fill=the color of the interior of a closed figure

Pattern=one of 10 "fill" patterns

Appl=a mnemonic referencing a particular application (c.g. forms manager, word-processor, report generator, etc.); allows multiple processes to share a single picture.

Tag=a variable-length, null-terminated string, supplied by the user; it can be used by applications to identify particular elements or classes of elements, or to store additional attributes

The attributes relating to the "type" field if designated "text" are as follows:

Options=wordwrap, bold, underline, italic, border, left-justify, right-justify, centered, top of box, bottom of box, middle of box, indent, tabs, adjust box size, character size, character/line spacing, and typeface

Select=indicates a currently selected substring by offset from beginning of string, and length

String=any number of bytes containing ASCII codes, followed by a single null byte; the text will be constrained to fit within the element's "box", automatically breaking to a new row when it reaches the right boundary of the area

Indent=two numbers specifying the indentation of the first and subsequent rows of text within the element's "box"

Tabs=list of [type, position], where "position" is the number of characters from the left edge of the element's box, and "type" is either Left, Right, or Decimal

Grow=maximum number of characters (horizontally) and lines (vertically) by which the element's box may be extended by typed input; limits growth right and downward, respectively

Size=height of the characters' extent and relative width

Space=spacing between lines of text and between characters

Face=name of a particular typeface

The attributes relating to the "type" field if designated "line" are as follows:

Style=various options such as solid, dashed, dotted, double, dashed-dotted, dash-dot-dot, patterned, etc.

Pattern=a pattern number

Thick=width of the line in pixels

Points=two or more pairs of coordinates (i.e. points) relative to the upper left corner of the box defined in the header

The attributes relating to the "type" field if designated "rectangle" are as follows:

Style=same as for "line" above, plus solid with a shadow

Pattern=same as for "line"

Thick=same as for "line"

Round=radius of a quarter-circle arc which will be drawn at each corner of the rectangle

The attributes relating to the "type" field if designated "ellipse" are as follows:

Style=solid, patterned, or double

Pattern=same as for "line"

Thick=same as for "line"

Arc=optional start- and end-angles of an elliptical arc

The attributes relating to the "type" field if designated "circle" are as follows:

Style=same as for "ellipse"

Pattern=same as for "line"

Thick=same as for "line"

Center=a point specifying the center of the circle, relative to the upper left corner of the element's box

Radius=length of the radius of the circle

Arc=optional start- and end-angles of a circular arc

A "symbol" is a rectangular space containing pixels which are visible (drawn) or invisible (not drawn). It is represented by a two-dimensional array, or "bit-map" of 1's and 0's with its origin in the upper left corner.

The attributes relating to the "type" field if designated "symbol" are as follows:

Bitmap=a two-dimensional array (in row and column order) containing single bits which are either "1" (draw the pixel in the foreground color) or "0" (draw the pixel in the background color); the origin of the array corresponds to the starting location of the element

Alt=A text string which can be displayed on non-bit-mapped devices, in place of the symbol

An array element is a rectangular space containing pixels which are drawn in specific colors, similar to a symbol element. It is represented as a two-dimensional array, or "bit-map", of color numbers, with its origin in the upper left corner. The element's "fill" and "pattern" are ignored.

Preceding an item with "+" indicates that the item is currently "active" and causes a check mark to be displayed beside it whenever the menu is opened. Preceding an item with "-" indicates that the corresponding option is not currently available and cannot be selected.

An "arguments" string can be appended to the tag of an element in the menu. The string is passed "as is" to the application when the item is selected.

PROMPT

The greater part of a prompt picture comprises text which asks a question, often with some introductory preamble. One element, located anywhere in the picture, may represent a response area. This is generally a rectangular area into which a user can type the information requested by the prompt. This element must be tagged "RESP".

Two further elements, tagged "ENTER" and "CANCEL", display target text or symbols which are used to complete the prompt. When the "enter" element is selected by the user, the text typed in the response area is returned to the originator of the prompt.

If the "cancel" element is selected instead, the prompt is cancelled with a null response. The response element is optional. If omitted, the "enter" and "cancel" elements effectively correspond to "yes" or "no" responses. Typing a "carriage return" character will have the same effect as selecting "enter". The prompt is erased when any response is given, or by an explicit "cancel" request.

INFORMATION

An information picture comprises text (and possibly graphics) which describes something. One element, located anywhere in the picture, is usually tagged "DONE". When this element is selected, the information picture is erased from the display. If no such element is given, the process which requested the information to be displayed must send an explicit "cancel" request when it wants to get rid of it.

INPUT/OUTPUT DEVICE INDEPENDENCE

In the present invention all system interaction with the outside world is either through "virtual input" or "virtual output" devices. The system can accept any form of input or output device. The Human Interface is constructed using a well-defined set of "virtual devices". All Human Interface functions (windowing, picture—drawing, dialog management, etc.) use this set of devices exclusively.

These virtual input devices take the form of "keys" (typed textual input); "position" (screen coordinates); "actions" (Human Interface functions such as "open window", etc.); "functions" (user-defined actions); and "means" (pop-up lists of choices).

Virtual output devices produce device-independent output: text, lines, rectangles, polygons, circles, ellipses, discrete points, bit-mapped symbols, and bit-mapped arrays.

FIG. 12 shows how the console manager operates upon virtual input to generate virtual output. The lowest layer of HI software converts input from any "real" physical devices to the generic, virtual form, and it converts Human Interface output (in virtual form) to physical output.

FIG. 12 shows the central process of the Human Interface, the console manager 220, dealing with virtual input and producing virtual output. Virtual input passed through the virtual input manager 221 is processed directly by the console manager 220, while output is passed through two intermediate processes—(1) a picture manager 222, which manipulates device-independent graphical images, and (2) a window manager 224, which presents a subset (called a "view") of the overall picture to the virtual output manager 226.

Any number of physical devices can be connected to the Human Interface and can be removed or replaced dynami-

cally, without disturbing the current state of the Human Interface or of any applications using the Human Interface. In other words, the Human Interface is independent of particular I/O devices, and the idiosyncracies of the devices are hidden from the Human Interface.

FIG. 13 represents a flowchart showing how virtual input is handled by the console manager. The virtual input may take any of several forms, such as a keystroke, cursor position, action, function key, menu, etc.

For example, regarding the operations beneath block 231, if the virtual input to the console manager is a keystroke, then the console manager checks to see whether the cursor is inside a window. If so, it checks to see whether it originated from a virtual terminal, and if not it checks to see whether an edit operation is taking place. If not, it updates the picture.

Regarding the operations beneath block 232, if the virtual input represents a cursor position, then the console manager checks to see whether the auto-highlight option has been enabled. If yes, it checks to see whether the cursor is on an element. If so it highlights that element.

Regarding the operations beneath block 233, the console manager uses any of the indicated actions to update a picture, update a window, or initiate dialog, as appropriate.

Regarding the operations beneath block 234, if the virtual input is from a function key, the console manager notifies the dialog manager.

Regarding the operations beneath block 235, if the virtual input represents a menu choice, the console manager checks to see whether the cursor is in a window. If not, it determines that it is on a user metaphor; if so, it requests a menu from the window. If the menu is defined, it notifies the owner of the window (or metaphor), activates a pop-up menu, gets a response, and sends the response to the window owner.

FIG. 14 represents a flowchart showing how virtual output is handled by the picture manager. The picture manager 240 accepts virtual output from the console manager and then, depending upon the type of operation, performs the requested function. For example, if the operation is a replace operation, the picture manager 240 replaces the old output with the new and sends the change(s) to the window manager. The window manager sends the change to the output manager, which in turn sends it to the real device.

DESCRIPTION OF SOURCE CODE LISTING

Program Listings A and B contain a "C" language implementation of the above-described concepts relating to input/output device independence. The following chart indicates where the relevant portions of the listing may be found.

Function	Lines Numbers in Program Listing A
Main-line; initialization; accept input	190-222
Determine type of input	486-521
Virtual key	523-631
Virtual position	633-661
Virtual action	663-702, 763-1200
Virtual function	704-723
Virtual menu	725-761
	Lines Numbers in Program Listing B
Main-line; initialization; start processing	125-141
Accept requests (virtual output); check for changes	161-203
Determine type of request	239-310

PROGRAM LISTING B

```

Module submitted
Date submitted
Author Frank Kolnick
Origin
Description
*****
#define lint
static char SrcId[] = "%z% %m%:t%";
#endif
/* picture manager: global data */
#include <cx.h>
#include <fill.h>
#include <memory.h>
#include <string.h>
static long none = 0;

typedef struct element_node
{
  struct element_node *next;
  struct element_node *prev;
  unsigned char changed;
  unsigned char marked;
  unsigned char deleted;
  unsigned char pool;
  short length;
  short *NOTE; /* length must start on a long-word boundary */
} ELEMENT;

typedef struct current_state
{
  char CONNECTOR;
  long msg;
  long sender;
  short appl;
  short row;
  short appl_col;
  char *mark;
  char *old mark;
  char *erase mark;
  char *display mark;
  unsigned char *privat;
  unsigned char *check;
  unsigned char *debug;
  unsigned char *light;
  unsigned char *name;
  unsigned char *file;
  unsigned char *code;
  long status;
  long *string;
} CURRENT;

90
91
92
93
94
95
96
97
98
99
100
101
102
103
104
105
106
107
108
109
110
111
112
113
114
115
116
117
118
119
120
121
122
123
124
125
126
127
128
129
130
131
132
133
134
135
136
137
138
139
140
141
142
143
144
145
146
147
148
149
150
151
152
153
154
155
156
157
158
159
160

```



```

61 typedef struct view_node
62 {
63     struct view_node
64     *nxt;
65     owner;
66     short
67     row, col, width;
68     height;
69 } VIEW;
70
71 typedef struct appl_node
72 {
73     struct appl_node
74     *nxt;
75     name;
76     long
77     conn;
78     short
79     row, col;
80 } APPL;
81
82 typedef struct anim_node
83 {
84     struct anim_node
85     *nxt;
86     name;
87     long
88     conn;
89 } ANIM;
90
91 typedef struct affected_area
92 {
93     short
94     r1, c1;
95     short
96     r2, c2;
97     char
98     color;
99     short
100     pattern;
101     short
102     max height;
103     short
104     max width;
105     short
106     height, width;
107 } AREA;
108
109 typedef struct lists
110 {
111     ELEMENT
112     *first;
113     ELEMENT
114     *current;
115     VIEW
116     *views;
117     ANIM
118     *apps;
119     int
120     changes;
121     int
122     erases;
123     struct
124     (
125         long
126         size;
127         long
128         *ptr;
129         ELEMENT
130         pool;
131     ) LIST;

```

```

/* links viewports: */
/*
/* ->next node */
/* owner of viewport */
/* start of viewport */
/* extent */
/*
/* links applications: */
/*
/* ->next node */
/* name of application */
/* conn. to application */
/* origin */
/*
/* links animation processes: */
/*
/* ->next node */
/* name of element */
/* conn. to process */
/*
/* area changed by a request: */
/*
/* upper left front */
/* lower right back */
/* background color */
/* background pattern */
/* max. height */
/* max. width */
/* current size */
/*
/* list pointers, etc.: */
/*
/* pict. element list */
/* ->end of p.e. changed */
/* ->last p.e. list */
/* ->viewports list */
/* ->applications list */
/* ->animation list */
/* ->changes in lists */
/* ->erases elements */
/* ->picture pool descr.: */
/*
/* elements */
/* size of elements */
/* ->element buffer */

```

```

117 /* local functions */
118 char *value() *tag() !
119 #define MARK_ELEMENT *mark_number() ! *mark_area() *mark_elements(), *new_element();
120 #define NEXT_ELEMENT *next_macro(); *next_macro();
121 #define MAIN_LINE /* Picture manager: main-line */
122 #define CURRENT cur;
123 #define AREA area;
124 #define LIST list;
125 #define REGISTER VIEW *view;
126 #define ANIM *anim;
127
128
129
130
131
132
133 Set event key ("picture mgr. ");
134 init_pm(&cur, &area, &list);
135 draw_picture(&cur, &area, &list);
136 for (view = list.views; view != view->nxt; view = view->nxt)
137 put(DIRECT, view->owner.pid, Newmsg(32, "unmap", NULL));
138 for (anim = list.anims; anim != anim->nxt; anim = anim->nxt)
139 put(DIRECT, anim->conn.pid, Newmsg(32, "quit", NULL));
140 Exit();
141
142
143
144
145
146
147
148
149
150
151
152
153
154
155
156
157
158
159
init_pm(cur, area, list)
register CURRENT *cur;
register AREA *area;
register LIST *list;
area->color = BLACK;
area->pattern = 0;
*cur->hname = *cur->file = NULL;
area->max_height = list->max_v; area->max_w = list->last = NULL;
list->current = list->first = list->last = NULL;
list->views = NULL;
list->anims = NULL;
list->size = list->pool.n = 0;
list->check = cur->private = cur->display_mark = NO;
cur->debug = cur->old_mark = cur->erase_mark = NULL;
cur->mark = cur->old_mark = cur->erase_mark = NULL;

```

What is claimed is:

1. A virtual input interface in a data processing system, said interface comprising:

means for accepting input from at least one physical device and for converting said physical device input into virtual input, said means comprising a virtual input manager process responsive to said at least one physical input device for generating a picture, said picture comprising one or more picture elements, each picture element comprising a plurality of device-independent data structures in a predetermined, standard data format, at least one of said data structures comprising a plurality of different data fields each containing information describing said picture element; and

means responsive to said virtual input for performing processing operations upon said virtual input, said means comprising a console manager process for performing processing operations on said one or more picture elements.

2. The virtual input interface as recited in claim 1, wherein said input accepting means accepts input in the form of keystrokes.

3. The virtual input interface as recited in claim 1, wherein said input accepting means accepts input in the form of cursor position.

4. The virtual input interface as recited in claim 1, wherein said input accepting means accepts input in the form of system-defined actions.

5. The virtual input interface as recited in claim 1, wherein said input accepting means accepts input in the form of user-defined functions.

6. The virtual input interface as recited in claim 1, wherein said input accepting means accepts input in the form of menu selections.

7. The virtual input interface as recited in claim 1, wherein said at least one physical device can be removed from said system without affecting the operation of the remainder of said system.

8. The virtual input interface as recited in claim 1, wherein at least one additional physical device can be added to said system without affecting the operation of the remainder of said system.

9. A virtual output interface in a data processing system, said interface comprising:

a source of virtual input, said virtual input comprising one or more picture elements, each picture element comprising a plurality of device-independent data structures in a predetermined, standard data format, at least one of said data structures comprising a plurality of different data fields each containing information describing said picture element;

means for performing processing operations on said virtual input and for generating virtual output;

means for accepting said virtual output; and

means for converting said virtual output into at least one physical output suitable for use by at least one physical output device.

10. The virtual output interface as recited in claim 9, wherein said virtual input comprises a plurality of related picture elements and wherein said virtual output accepting means comprises a picture manager process for controlling said plurality of related picture elements.

11. The virtual output interface as recited in claim 10 and further comprising a display device, wherein said virtual output accepting means further comprises a window manager process for controlling the display of said plurality of related picture elements on said display device.

12. The virtual output interface as recited in claim 9, wherein said virtual output converting means comprises a virtual output manager process responsive to said one or more processed picture elements for coupling said one or more processed picture elements to said at least one physical output device.

13. The virtual output interface as recited in claim 9, wherein said at least one physical device can be removed from said system without affecting the operation of the remainder of said system.

14. The virtual output interface as recited in claim 9, wherein at least one additional physical device can be added to said system without affecting the operation of the remainder of said system.

15. In a data processing system, an interface between processes and data in said system and physical input and output devices coupled to said system, said interface comprising:

means responsive to one of said physical input devices for generating a picture, said picture comprising one or more picture elements, each picture element comprising a plurality of device-independent data structures in a predetermined, standard data format, at least one of said data structures comprising a plurality of different data fields each containing information describing said picture element;

means for performing processing operations on said one or more picture elements; and

means responsive to said one or more processed picture elements for coupling said one or more processed picture elements to one of said physical output devices.

16. The data processing system as recited in claim 15, wherein said one or more picture elements define a graphical object and at least one attribute thereof.

17. The data processing system as recited in claim 16, wherein one of said data fields describes the length of the associated picture element.

18. The data processing system as recited in claim 16, wherein one of said data fields identifies the particular type of the associated picture element.

19. The data processing system as recited in claim 16, wherein one of said data fields describes the position of the associated picture element relative to row and column coordinates on a picture of which said picture element forms a part.

20. The data processing system as recited in claim 16, wherein one of said data fields describes the size of the associated picture element.

21. The data processing system as recited in claim 16, wherein one of said data fields describes the color of the associated picture element.

22. The data processing system as recited in claim 15, wherein said means responsive to one of said physical input devices comprises a virtual input manager process.

23. The data processing system as recited in claim 15, wherein said means responsive to said one or more processed picture elements comprises a virtual output manager process.

* * * * *

**E
X
H
I
B
I
T**

37



US005502839A

United States Patent [19]

[11] Patent Number: **5,502,839**

Kolnick

[45] Date of Patent: **Mar. 26, 1996**

[54] **OBJECT-ORIENTED SOFTWARE ARCHITECTURE SUPPORTING INPUT/OUTPUT DEVICE INDEPENDENCE**

[75] Inventor: Frank C. Kolnick, Willowdale, Canada

[73] Assignee: Motorola, Inc., Schaumburg, Ill.

[21] Appl. No.: 361,738

[22] Filed: Jun. 2, 1989

Related U.S. Application Data

[63] Continuation of Ser. No. 619, Jan. 5, 1987, abandoned.

[51] Int. Cl.⁶ G06F 13/00

[52] U.S. Cl. 395/800; 364/228.2; 364/237.9; 364/239.9; 364/280; 364/284.2; 364/DIG. 1

[58] Field of Search 364/200 MS File, 364/900 MS File; 395/500

[56] References Cited

U.S. PATENT DOCUMENTS

3,930,232	12/1975	Wallach et al.	395/500
4,241,341	12/1980	Thorson	340/747
4,454,593	6/1984	Fleming	364/900

4,485,439	11/1984	Rothstein	395/500
4,547,628	10/1985	Tamura et al.	340/747
4,555,775	11/1985	Pike	364/900
4,559,614	12/1985	Peek et al.	364/900
4,642,790	2/1987	Minshull et al.	364/900
4,754,395	6/1988	Weisshaar et al.	364/200
4,800,523	1/1989	Gerety et al.	395/500
4,858,114	8/1989	Heath et al.	395/500
5,063,494	11/1991	Davidowski et al.	395/800

Primary Examiner—Kevin J. Teska
Assistant Examiner—Ayni Mohamed
Attorney, Agent, or Firm—Walter W. Nielsen; Harold C. McGurk; S. Kevin Pickens

[57] ABSTRACT

An object-oriented software architecture interacts with "real" input/output devices exclusively through "virtual" input/output devices. Since all human interface with the operating system is performed through such virtual devices, the system can accept any form of real input or output devices. The lowest level of the operating system converts input from any physical device to virtual form and converts virtual output into suitable physical output. Any number of physical devices can be connected to, removed from, or replaced in the system without disrupting the system.

23 Claims, 9 Drawing Sheets

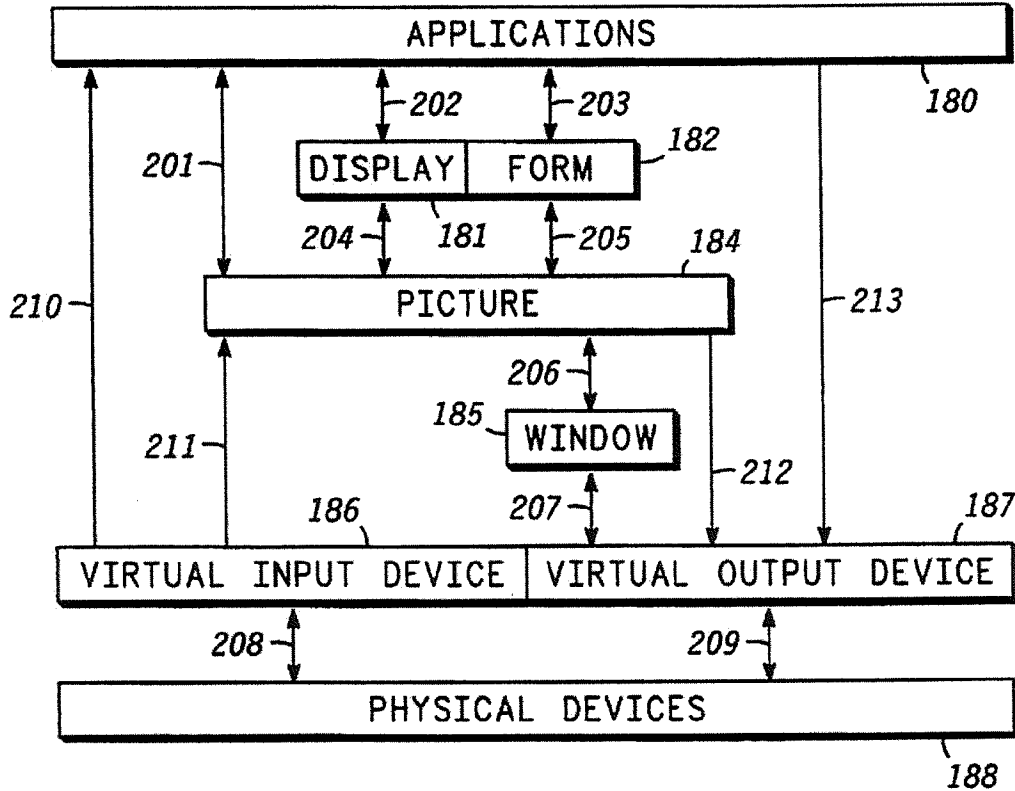

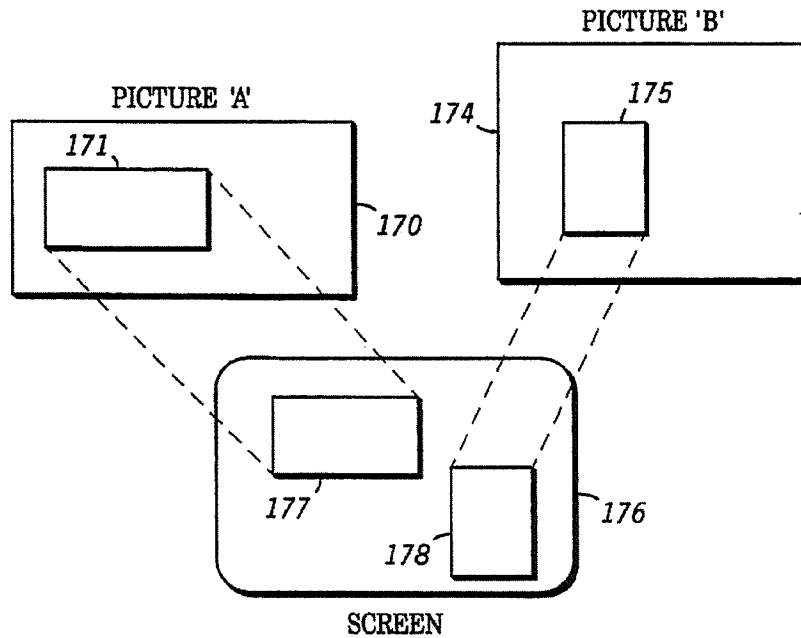
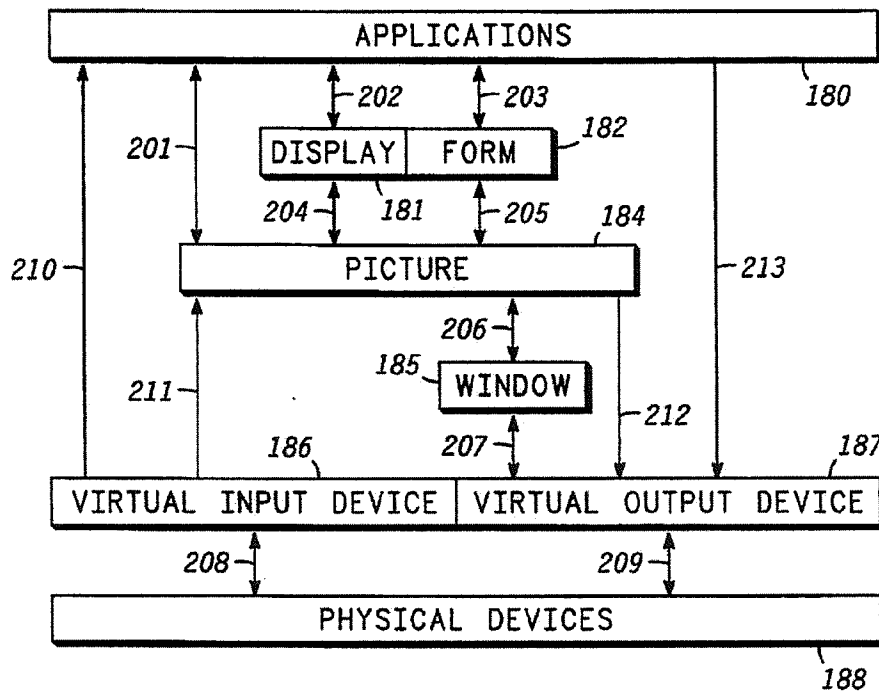

FIG. 7

FIG. 8



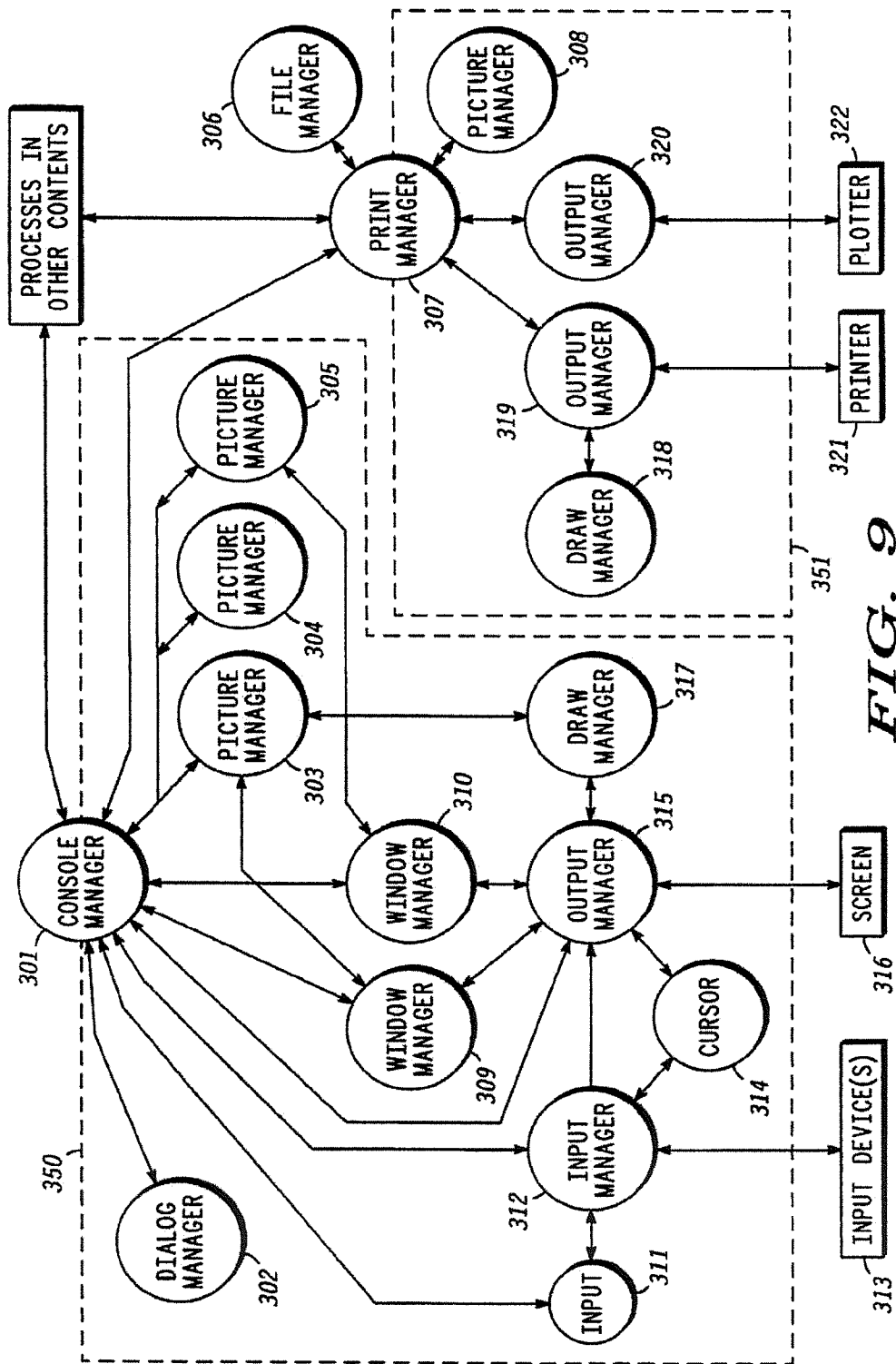

FIG. 9

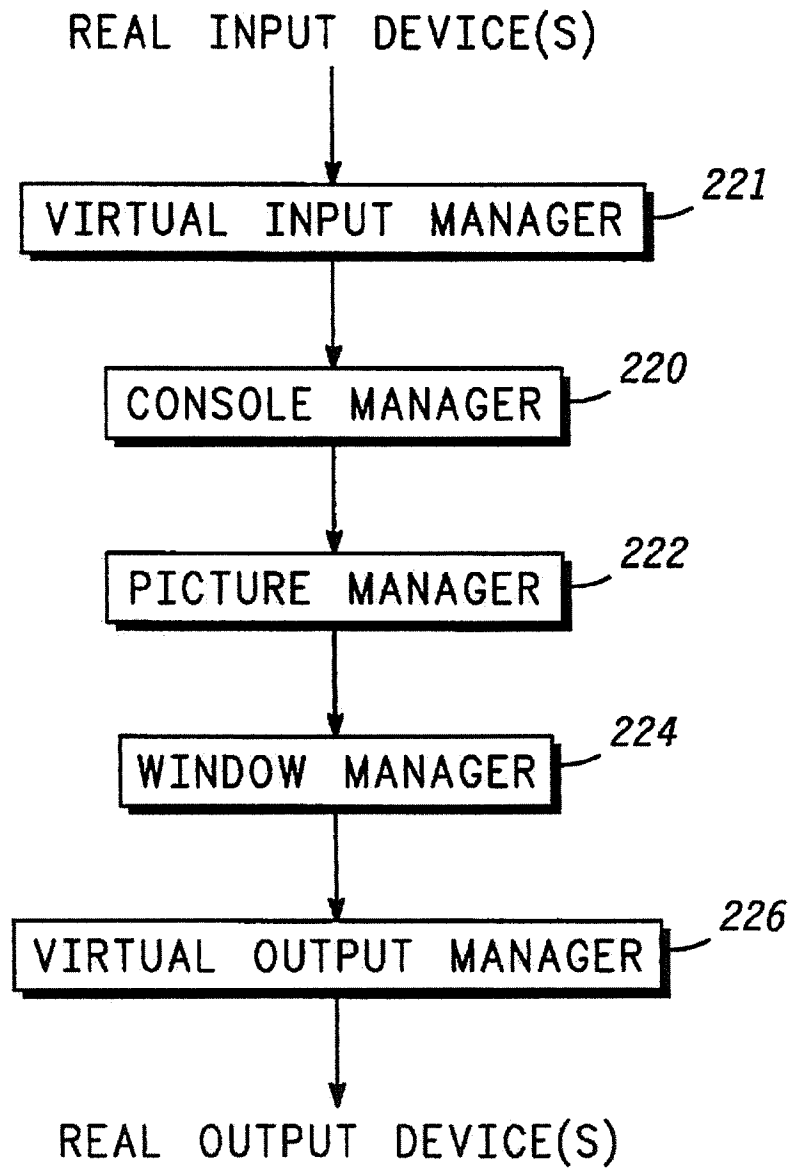

FIG. 12

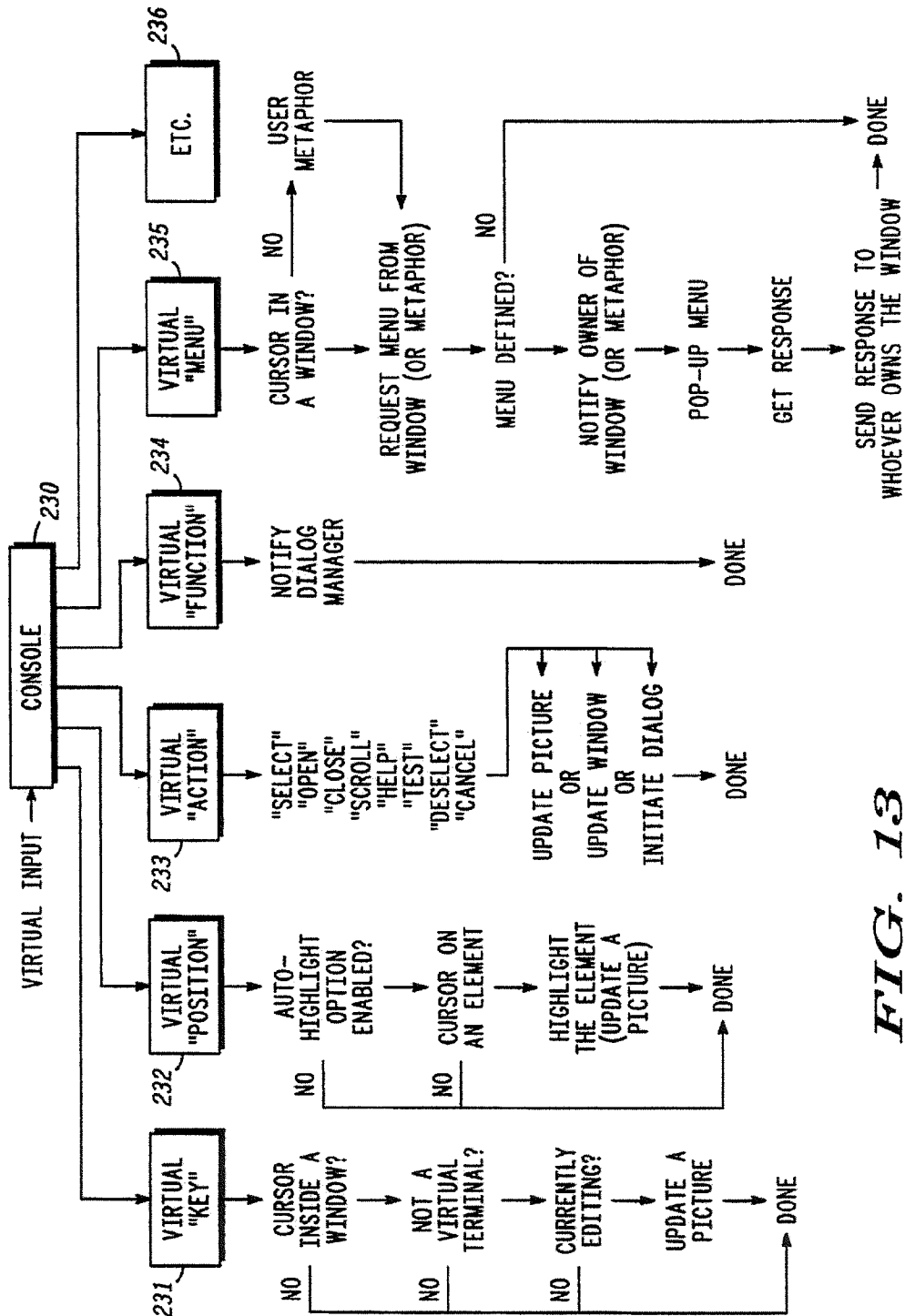

FIG. 13

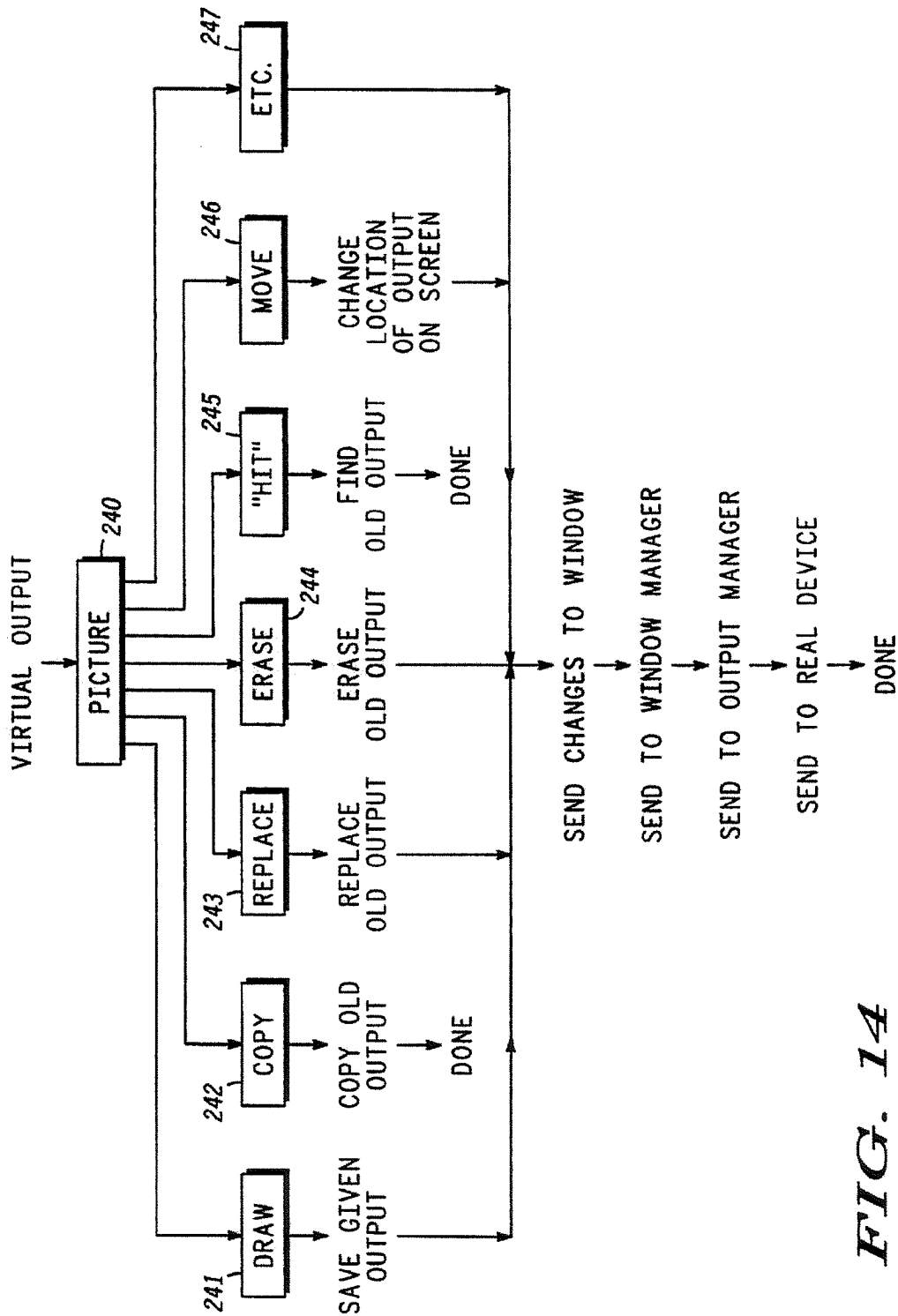

FIG. 14

cut off at any time. (This is generally useful only if the output device is a screen.)

In general, input is sent as single "characters", each in a single "K" (i.e. keyboard string) message (unbuffered) to the specified process(es). Some characters, such as "shift one" or a non-spacing accent, are temporarily buffered until the next character is typed and are then sent as a pair. Redefinable characters, including all displayable text, cursor control commands, "action keys", etc. are sent as triples.

New output devices can be added to the "virtual keyboard" at any time by re-initializing the manager and down-loading the appropriate parameters, followed by a "proceed". All input is suspended while this is being done. Previously down-loaded parameters and the screen assignment are not affected. Similarly, devices can be disconnected by terminating (sending "quit" requests for) them individually. A nonspecific "quit" terminates the entire manager.

Where applicable, an Input Manager will support requests to activate outputs on its device(s), such as lights or sound generators (e.g., a bell).

The Input Process is a distinct process which is created by each Console Manager for its Input Manager to keep track of the current input state. In general, this includes a copy of its last input of each type (text, function key, pointer, number, etc.), the current redefinable character set number, as well as Boolean variables for such conditions as "keyboard locked", "select key depressed" (and being held down), etc. The process is simply named "In". The Input Manager is responsible for keeping this process up-to-date. Any process may examine (but not modify) the contents of "In".

Output Manager—There is one Output Manager per physical output device (screen, printer, plotter, etc.) connected to the system. Each Output Manager converts (and possibly scales) standard "pictures" into the appropriate representation on its particular device.

The Output Manager knows about the following processes: the process which initialized it, and the Draw Manager in the same context. The following processes know about the Output Manager: the Console Manager in the same context, the Input Manager in the same context, and the Window Manager in the same context.

An Output Manager is created (automatically, at system start-up) for each physical output device in the system, thus implementing numerous "virtual screens". There can be any number of such devices per Console context. The software (message) interface to each manager is identical, although their internal behavior is dependent upon the physical device(s) to which they communicate. All output interrupt service routines (if any) are contained in Output Manager and hidden from other processes. Each manager also controls a process called Cursor which holds information concerning its own cursor. When ready, each Output Manager must send an "I'm here" message to the closest process named "Console".

An Output Manager must be explicitly initialized and told to proceed before it can begin to actually write to its device. Both of these are performed using appropriate Human Interface messages. Which process initializes the manager becomes tightly coupled to it; i.e., they can exchange messages via PID's rather than by name. This coupling cannot be changed dynamically; the manager would have to be re-initialized. Between the "initialize" and the "proceed" an Output Manager may be sent one or more "set" requests to define its behavior. Device-independent parameters (such as pixel size and density) are not down-loaded but rather are assumed to be built into the software, some part of which, in

general, must be unique to each type of Output Manager. Things like a screen's background color and pattern are down-loadable at start-up time and at any other time.

In general, an Output Manager is driven by "draw" commands (containing standard picture elements) sent to it by any process (usually a Window Manager). Its primary function then is to translate picture elements, described in terms of virtual pixels, into the appropriate sequences of output to its particular device. It uses the Draw Manager to expand elements into sets of real pixels and keeps the Cursor process informed of any resulting changes in cursor position. It looks up colors and shading patterns in predefined tables. The "null" color (zero) is interpreted as "draw nothing" whenever it is encountered. A "clear" request is also supported. It changes a given polygonal area to the screen's default color and shading pattern.

Any "draw" request can be preceded by a "clip" request. "Clip" means "don't display pixels outside of given polygon", i.e. only the logical AND of the polygonal area and the given picture elements is drawn. The clip request applies only to the next draw request received from the same process and is then discarded.

"Text" elements are displayed by the output device's built-in character generator, if possible. However, most text is created from predefined bit-maps which are stored in a Human Interface library. Different bit-maps exist for various combinations of font and size. Sizes which are not explicitly stored must be calculated from the available bit-maps when required. The style is always generated dynamically, i.e., it is calculated from the basic bit-map.

Output Managers also accept "K" messages (i.e. keyboard strings) containing cursor movement commands. If the associated device is a screen, the manager erases the cursor from its current position (if necessary, i.e. if the cursor is not supported directly by the hardware) and redraws it in its new location. It uses the Cursor Process to get a symbol element representing the cursor's current shape and color, and it tells it the new location after it has redrawn the cursor. (The manager may have to ask its initializing process to redraw the part of the picture which was previously obscured by the cursor after it moves it.) If the associated device is not a real screen, cursor movement commands are simply ignored.

If possible, an Output Manager should be able to save, restore, move, and copy rectangular areas of the virtual screen. These are primarily speed-optimizing operations, and they need not always be supplied. In general, an Output Manager can be queried for its characteristics, e.g., whether it supports the above functions, whether it is bit-mapped or character-oriented, the output dimensions (in pixels or characters, as appropriate), the physical size, etc.

The Cursor Process is a distinct process which is created by each Console Manager in its context to keep track of the cursor. That process, which has the same name as the screen (not the Output Manager), knows the current location of the cursor, all of the symbols which may represent the cursor on the screen, which symbol is currently being used, how many real pixels to move when a cursor movement command is executed, etc. It can, in general, be accessed for any of this information at any time by any process. The associated Output Manager is the prime user of this process and is responsible for keeping it up to date. The associated Input Manager (if any) is the next most common user, requesting the cursor's position every time it processes a "command" input.

Dialog Manager—There is one Dialog Manager per console, and it provides access to a library of "pictures" which define the menus, help texts, prompts, etc. for the Human

Interface (and possibly the rest of the system), and it handles the user interaction with those pictures.

The Dialog Manager knows about the following processes: none. The following processes know about the Dialog Manager: the Console Manager in the same context. 5

One Dialog Manager is created automatically, at system start-up, in each Console context. Its function is to handle all visual interaction with users through the input and output managers. Its purpose is to separate the external representation of such interaction from its intrinsic meaning. For example, the Console Manager may need to ask the user how many copies of a report he wants. The phrasing of the question and the response are irrelevant—they may be in English, Swahili, or pictographic, so long as the Console Manager ends up with an integral number or perhaps the response “forget it”. 15

In general, the Dialog Manager can be requested to load (from a file) or dynamically create (from a given specification) a picture which represents a menu, error message, help (informational) text, prompt, a set of icons, etc. This picture is usually displayed until the user responds. 20

Response to help or error text is simply acknowledgement that the text has been read. The response to a prompt is the requested information. The user can respond to a menu by selecting an item in the menu or by cancelling the menu (and thus cancelling any actions the menu would have caused). Icons can be selected and then moved or “opened”. Opening an icon generally results in an associated application being run. 25

“Selection” is done through an Input Manager which sends a notification to the Console Manager. The Console Manager filters this response through the Dialog Manager which interprets it and returns the appropriate parameter in a message which is then passed on to the process which requested the service. 30

All dialog is represented as pictures, mostly in free format. Help and error dialog are the simplest and are unstructured except that one element must be “tagged” to identify it as the “I have read this text” response target symbol. The text is displayed until the user selects this element. 40

Prompts have three tagged elements: one which defines the response area (i.e., where the user will type the information requested by the prompt), a “cancel” target, and an “enter” target. The prompt is displayed until either one of the latter two elements is selected. The response is returned as a text string, with an indication of which target element was selected. The “response” element may be omitted, in which case the prompt is just a question and the response is a simple yes or no (represented by “enter” and “cancel”). 45

A menu picture is highly structured. The first element must be a text element which contains the menu’s title for display and for reference by the software. This may be followed by an “explanation” element to describe the menu items. Neither of these elements is selectable. 50

The menu proper contains a list of “macro” picture elements, one per selectable choice or “item”. Each macro consists of three elements. The first element is mandatory and describes the item (via text or a symbol). It must contain a tag which is what is actually sent back to the requesting process when the item is selected, along with the item’s ordinal number (1 to n, of there are n items). For example, the item element may define an icon, such as a house. The tag might be “H” or “house” or anything else the system designer feels is appropriate. An item number of zero and a tag of “NONE” are sent if the menu is closed without selecting any item. A single character may optionally be 55

associated with the element. Typing the given character on the keyboard has the same effect as selecting the item from the menu.

The second and third elements in the macro are optional and may be represented by null strings (a single null byte) if not required. The second element describes the “alternate” state of the item. It is displayed when the item is selected and remains in effect until the item is selected again. In other words, the item is toggled between two options. The element must contain a tag (as described for the first element) to identify it. The third element describes the “unavailable” state of the item, and it is displayed when that particular option is marked as not being selectable at the time the menu is requested, as described below.

The last element in the menu picture is a simple text string consisting of a pair of characters for each item in the menu. The list describes whether the item is available (can be selected) or unavailable and which is its current state (normal or alternate). This list can (and should) be changed dynamically by messages to the Dialog Manager to reflect the current options available to the user.

Icons are small pictures which represent applications or services and are organized into sets (or “frames of reference”) of related functions. A set is a picture composed of “macro” elements, one per icon. Each macro comprises a single “symbol” element (which may itself be a macro) and a text element describing the label to be displayed with the symbol. The label element may be null. The macro element must be tagged with the name of the process to which notification is sent when the icon is “opened”, and it must specify whether a window should be opened automatically before sending the notification.

Draw Manager—There is one Draw Manager per console, and it provides access to a library of “pictures” which define the menus, help, prompts, etc., for the Human Interface (and possibly the rest of the system), and it handles the user interaction with those pictures.

The Draw Manager knows about the following processes: none. The following processes know about the Draw Manager: the Picture Managers in the same context, and the Output Managers in the same context.

One Draw Manager is created automatically, at system start-up, in each context that requires expansion of picture elements into bit-maps. Its sole responsibility is to accept one or more picture elements, of any type, in one message and return a list of bit-map (“symbol”) elements corresponding to the figure generated by the elements, also in one message. Various parameters can be applied to each element, most notably scaling factors which can be used to transform an element or to convert virtual pixels to real pixels. The manager must be told to exit when the context is being shut down.

Window Manager—There is one per current instance of a “window” on a particular screen. A Window Manager is created when the window is opened and exits when the window is closed. It maps a given picture (or portion thereof) to a rectangular area of a given size on the given screen; i.e., it logically links a device-independent picture to a device-dependent screen. A “frame” can be drawn around a window, marking its boundaries and containing other information, such as a title or menu. Each manager is also responsible for updating the screen whenever the contents of its window changes.

The Window Manager knows about the following processes: the process that created it; one particular Picture Manager in the same context; and one particular Output Manager in the same context. The following processes know 55

about the Window Manager: the Console Manager in the same context.

The Window Manager's main job is to copy picture elements from a given rectangular area of a picture to a rectangular area (called a "window") on a particular screen. To do so it interacts with exactly one Picture Manager and one Output Manager. A Window Manager need only be created when a window is "opened" on the screen and can be told to quit when the window is "closed" (without affecting the associated picture). When opened, the Window Manager must draw the outline, frame, and background of the window. When closed, the window and its frame must be erased (i.e. redrawn in the screen's background color and pattern). "Moving" a window (changing its location on the screen) is essentially the same as closing and re-opening it.

A Window Manager can only be created and destroyed by a Console Manager, which is responsible for arranging windows on the screen, resolving overlaps, etc. When a Window Manager is created, it waits for an "initialize" message, initializes itself, returns an "I'm here" message to the process which sent it the "initialize" message, then waits for further messages. It does not send any messages to the Output Manager until it has received all of the following: its dimensions (exclusive of frame), the outline line-type, size and color, background color, location on the screen, a clipping polygon, scaling factors, and framing parameters. A Window Manager also has an "owner", which is a particular process which will handle commands (through the Console Manager, which always has prime control) within the window.

Any of the above parameters can be changed at any time. In general, changing any parameter (other than the owner) causes the window to be redrawn on the screen.

A "frame", which may consist of four components (called "bars"), one along each edge of the window, may be placed around the given window. The bars are designated top, bottom, left, and right. They can be any combination of simple line segment, title bar, scroll bar, menu bar, and palette bar. These are supplied to the message as four separate lists (in four separate messages) of standard picture elements, which can be changed at any time by sending a new message referencing the bar. The origin of each bar is [0,0] relative to the upper left corner of the window.

The Console Manager may query a Window Manager for any of its parameters, to which it responds with messages identical to the ones it originally received. It can also be asked whether a given absolute cursor position is inside its window (i.e. inside the current clipping polygon) or its frame, and for the cursor coordinates relative to the origin of the window or any edge of the frame.

A Window Manager is tightly coupled to its creator (a Console Manager), Picture Manager, and Output Manager; i.e. they communicate with each other using process identifiers (PID's). Consequently, a Window Manager must inform its Picture Manager when it exits, and it expects the Picture Manager to do the same.

Once the Window Manager knows the picture it is accessing and the dimensions of its window (or any time either of these changes), it requests the Picture Manager to send it all picture elements which completely or partially lie within the window. It also asks it to notify it of changes which will affect the displayed portion of the picture. The Picture Manager will send "draw" messages to the Window Manager (at any time) to satisfy these requests.

The Window Manager performs gross clipping on all picture elements it receives, i.e. it just determines whether each element could appear inside the current clipping poly-

gon (which may be smaller than the window at any given moment, if other windows overlap this one).

A Window Manager can be told to "freeze" (stop updating) its display and to "unfreeze" it. It can also be asked to redraw any given rectangular sub-area of the picture it is displaying.

Window Managers deal strictly in virtual pixels and have no knowledge about the physical characteristics of the screen to which they are writing. Consequently, a window's size and location are specified in virtual pixels, implying a conversion from real pixels if these are different.

Print Manager—There is one per "output subsystem", i.e. per pool of output devices. The Print Manager coordinates output to hard-copy devices (i.e. to their Output Managers). It provides a comprehensive queuing service for files that need to be printed. It can also perform some minimal formatting of text (justification, automatic page numbering, headers, footers, etc.)

The Print Manager knows about the following processes: Output Managers in the same context, and a Picture Manager in the same context. The following processes know about the Print Manager: any one that wants to.

One Print Manager is created automatically, at start-up time, in each Print context. It is expected to accept general requests for hard-copy output and pass them on, one message (usually corresponding to one "line" of output) at a time, to the appropriate Output Manager. It can also accept requests which refer to files (i.e. to File Manager processes). Each such message, known as a "spool" request, also contains a priority, the number of copies desired, specific output device requirements (if any) and special form requirements (if any).

Based on these parameters, as well as the size of the file, the amount of time the request has been waiting, and the availability of output devices, the Print Manager maintains an ordered queue of outstanding requests. It dequeues them one at a time, select an Output Manager, and builds a picture (using a Picture Manager). It then requests (from the Picture Manager) and "prints" (plots, etc.) one "page" at a time until the entire file has been printed.

The Print Manager recognizes specially marked ("tagged") picture elements which define headers, footers, foot-notes, and page formatting parameters (such as "page break", "set page number", etc.).

HUMAN INTERFACE—RELATIONSHIPS BETWEEN COMPONENTS

The eight Human Interface components together provide all of the services required to support a minimal human interface. The relationships between them are illustrated in FIG. 9, which shows at least one instance of each component. The components represented by circles 301, 302, 307, 312, 315, and 317-320 are generally always present and active, while the other components are created as needed and exit when they have finished their specific functions. FIG. 9 is divided into two main contexts: "Console" 350 and "Print" 351.

Cursor 314 and Input 311 are examples of processes whose primary function is to store data. "Cursor"'s purpose is to keep track of the current cursor position on the screen and all parameters (such as the symbols defining different cursors) pertinent to the cursor. One cursor process is created by the Console Manager for each Output Manager when it is initialized. The Output Manager is responsible for updating the cursor data, although "Cursor" may be queried by anyone. "Input" keeps track of the current input state, such

as "select key is being held down", "keyboard locked", etc. One input process is created by each Console Manager. The console's input message updates the process; any other process may query it.

The Human Interface is structured as a collection of subsystems, implemented as contexts, each of which is responsible for one broad area of the interface. There are two major contexts accessible from outside the Human Interface: "Console" and "Print". They handle all screen/keyboard interaction and all hard-copy output, respectively. These contexts are not necessarily unique. There may be one or more instances of each in the system, with possibly several on the same cell. Within each, there may be several levels of nested contexts.

The possible interaction between various Human Interface components will now be described.

Console Manager/Other Contexts—Processes of other contexts may send requests for console services or notification of relevant events directly to the Console Manager(s). The Console Manager routes messages to the appropriate service. It also notifies (via a "status" message) the current owner of a window whenever an object in its window has been selected. Similarly, it sends a message to an application when a user requests that application in a particular window.

Console Manager/Input Manager—The Console Manager initializes the Input Manager and usually assigns a particular Output Manager to it. The Input Manager always sends all input (one character, one key, one cursor movement, etc. at a time) directly to the Console Manager. It may also send "status" messages, either in response to a "download", "initialize", or "terminate" request, or any time an anomaly arises.

Console Manager/Output Manager—The Console Manager displays information on its "prime" output device during system start-up and shut-down without using pictures and windows. It therefore sends picture elements directly to an Output Manager. The Console Manager is also responsible for moving the cursor on the screen while the system is running, if applicable. The Console Manager (or any other Human Interface manager, such as an "editor") may change the current cursor to any displayable symbol. Output Managers will send "status" messages to the Console Manager any time an anomaly arises.

Console Manager/Picture Manager—The Console Manager creates Picture Managers on demand and tells each of them the name of a file which contains picture elements, if applicable. A Picture Manager can also accept requests from the Console Manager (or anyone else) to add elements to a picture individually, delete elements, copy them, move them, modify their attributes, or transform them. It can be queried for the value of an element at (or close to) a given location within its picture. The Console Manager will tell a Picture Manager to erase its picture and exit when it is no longer needed. A Picture Manager usually sends "status" messages to the Console Manager whenever anything unusual (e.g., an error) occurs.

Console Manager/Window Manager—The Console Manager creates Window Managers on demand. Each Window Manager is told its size, the PID of an Output Manager, the coordinates (on the screen) of its upper left outside corner, the characteristics of its frame, the PID of a particular Picture Manager, the coordinates of the first element from which to start displaying the picture, and the name of the process which "owns" the window. While a window is active, it can be requested to re-display the same picture starting at a different element or to display a completely different picture.

The coordinates of the window itself may be changed, causing it to move on the screen, or it may be told to change its size, frame, or owner. A Window Manager can be told to "clip" the picture elements in its display along the edges of a given polygon (the default polygon is the inside edge of the window's frame). It can also be queried for the element corresponding to a given coordinate. The Console Manager will tell a Window Manager to "close" (erase) its window and exit when it is no longer needed. A Window Manager sends "status" messages to the Console Manager to indicate success or failure of a request.

Console Manager/Dialog Manager—The Dialog Manager accepts requests to load and/or dynamically create "pictures" which represent menus, prompts, error messages, etc. In the case of interactive pictures (such as menus), it also interprets the response for the Console Manager. Other processes may also use the Dialog Manager through the Console Manager.

Console Manager/Prime Manager—Console Managers generally send "spool" requests to Print Managers to get hard-copies of screens or pictures. An active picture must first be copied to a file. The Print Manager returns a "status" message when the request is complete or if it fails.

Window Manager/Picture Manager—A Window Manager requests lists of one or more picture elements from the relevant Picture Manager, specified by the coordinates of a rectangular "viewport" in the picture. It can also request the Picture Manager to automatically send changes (new, modified, or erased elements), or just notification of changes, to it. The Picture Manager sends "status" messages to notify the Window Manager of changes or errors.

Window Manager/Output Manager—A Window Manager sends lists of picture elements to its Output Manager, prefixed by the coordinates of a polygon by which the Output Manager is to "clip" the pixels of the elements as it draws them. A given list of picture elements can also be scaled by a given factor in any of its dimensions. The Output Manager returns a "status" message when a request fails.

Input Manager/Output Manager—The Input Manager sends all cursor movement inputs to a pre-assigned Output Manager (if any), as well as to the Console Manager. This assignment can be changed dynamically.

Print Manager/Other Processes—The Print Manager accepts requests to "spool" a file or to "print" one or more picture elements. It sends a "status" message at the completion of the request or if the request cannot be carried out. The status of a queued request can also be queried or changed at any time.

Print Manager/File Manager—The Print Manager reads picture elements from a File Manager (whose name was sent to it via a "spool" request). It may send a request to "delete" the file back to the File Manager after it has finished printing the picture.

Print Manager/Picture Manager—A Print Manager creates a Picture Manager for each spooled picture that it is currently printing, giving it the name of the relevant file. It then requests "pages" of the picture (depending upon the characteristics of the output device) one at a time. Finally, it tells the Picture Manager to go away.

Print Manager/Output Manager—The Print Manager sends picture elements to an Output Manager. The Output Manager sends a "status" message when the request completes or fails or when an anomaly arises on the printer.

Draw Manager/Other Processes—The Draw Manager accepts lists of elements prefixed by explicit pixel param-

Preceding an item with "+" indicates that the item is currently "active" and causes a check mark to be displayed beside it whenever the menu is opened. Preceding an item with "-" indicates that the corresponding option is not currently available and cannot be selected.

An "arguments" string can be appended to the tag of an element in the menu. The string is passed "as is" to the application when the item is selected.

PROMPT

The greater part of a prompt picture comprises text which asks a question, often with some introductory preamble. One element, located anywhere in the picture, may represent a response area. This is generally a rectangular area into which a user can type the information requested by the prompt. This element must be tagged "RESP".

Two further elements, tagged "ENTER" and "CANCEL", display target text or symbols which are used to complete the prompt. When the "enter" element is selected by the user, the text typed in the response area is returned to the originator of the prompt.

If the "cancel" element is selected instead, the prompt is cancelled with a null response. The response element is optional. If omitted, the "enter" and "cancel" elements effectively correspond to "yes" or "no" responses. Typing a "carriage return" character will have the same effect as selecting "enter". The prompt is erased when any response is given, or by an explicit "cancel" request.

INFORMATION

An information picture comprises text (and possibly graphics) which describes something. One element, located anywhere in the picture, is usually tagged "DONE". When this element is selected, the information picture is erased from the display. If no such element is given, the process which requested the information to be displayed must send an explicit "cancel" request when it wants to get rid of it.

INPUT/OUTPUT DEVICE INDEPENDENCE

In the present invention all system interaction with the outside world is either through "virtual input" or "virtual output" devices. The system can accept any form of input or output device. The Human Interface is constructed using a well-defined set of "virtual devices". All Human Interface functions (windowing, picture—drawing, dialog management, etc.) use this set of devices exclusively.

These virtual input devices take the form of "keys" (typed textual input); "position" (screen coordinates); "actions" (Human Interface functions such as "open window", etc.); "functions" (user-defined actions); and "means" (pop-up lists of choices).

Virtual output devices produce device-independent output: text, lines, rectangles, polygons, circles, ellipses, discrete points, bit-mapped symbols, and bit-mapped arrays.

FIG. 12 shows how the console manager operates upon virtual input to generate virtual output. The lowest layer of HI software converts input from any "real" physical devices to the generic, virtual form, and it converts Human Interface output (in virtual form) to physical output.

FIG. 12 shows the central process of the Human Interface, the console manager 220, dealing with virtual input and producing virtual output. Virtual input passed through the virtual input manager 221 is processed directly by the console manager 220, while output is passed through two intermediate processes—(1) a picture manager 222, which manipulates device-independent graphical images, and (2) a window manager 224, which presents a subset (called a "view") of the overall picture to the virtual output manager 226.

Any number of physical devices can be connected to the Human Interface and can be removed or replaced dynami-

cally, without disturbing the current state of the Human Interface or of any applications using the Human Interface. In other words, the Human Interface is independent of particular I/O devices, and the idiosyncracies of the devices are hidden from the Human Interface.

FIG. 13 represents a flowchart showing how virtual input is handled by the console manager. The virtual input may take any of several forms, such as a keystroke, cursor position, action, function key, menu, etc.

For example, regarding the operations beneath block 231, if the virtual input to the console manager is a keystroke, then the console manager checks to see whether the cursor is inside a window. If so, it checks to see whether it originated from a virtual terminal, and if not it checks to see whether an edit operation is taking place. If not, it updates the picture.

Regarding the operations beneath block 232, if the virtual input represents a cursor position, then the console manager checks to see whether the auto-highlight option has been enabled. If yes, it checks to see whether the cursor is on an element. If so it highlights that element.

Regarding the operations beneath block 233, the console manager uses any of the indicated actions to update a picture, update a window, or initiate dialog, as appropriate.

Regarding the operations beneath block 234, if the virtual input is from a function key, the console manager notifies the dialog manager.

Regarding the operations beneath block 235, if the virtual input represents a menu choice, the console manager checks to see whether the cursor is in a window. If not, it determines that it is on a user metaphor; if so, it requests a menu from the window. If the menu is defined, it notifies the owner of the window (or metaphor), activates a pop-up menu, gets a response, and sends the response to the window owner.

FIG. 14 represents a flowchart showing how virtual output is handled by the picture manager. The picture manager 240 accepts virtual output from the console manager and then, depending upon the type of operation, performs the requested function. For example, if the operation is a replace operation, the picture manager 240 replaces the old output with the new and sends the change(s) to the window manager. The window manager sends the change to the output manager, which in turn sends it to the real device.

DESCRIPTION OF SOURCE CODE LISTING

Program Listings A and B contain a "C" language implementation of the above-described concepts relating to input/output device independence. The following chart indicates where the relevant portions of the listing may be found.

Function	Lines Numbers in Program Listing A
Main-line; initialization; accept input	190-222
Determine type of input	486-521
Virtual key	523-631
Virtual position	633-661
Virtual action	663-702, 763-1200
Virtual function	704-723
Virtual menu	725-761
	Lines Numbers in Program Listing B
Main-line; initialization; start processing	125-141
Accept requests (virtual output); check for changes	161-203
Determine type of request	239-310

What is claimed is:

1. A virtual input interface in a data processing system, said interface comprising:

means for accepting input from at least one physical device and for converting said physical device input into virtual input, said means comprising a virtual input manager process responsive to said at least one physical input device for generating a picture, said picture comprising one or more picture elements, each picture element comprising a plurality of device-independent data structures in a predetermined, standard data format, at least one of said data structures comprising a plurality of different data fields each containing information describing said picture element; and

means responsive to said virtual input for performing processing operations upon said virtual input, said means comprising a console manager process for performing processing operations on said one or more picture elements.

2. The virtual input interface as recited in claim 1, wherein said input accepting means accepts input in the form of keystrokes.

3. The virtual input interface as recited in claim 1, wherein said input accepting means accepts input in the form of cursor position.

4. The virtual input interface as recited in claim 1, wherein said input accepting means accepts input in the form of system-defined actions.

5. The virtual input interface as recited in claim 1, wherein said input accepting means accepts input in the form of user-defined functions.

6. The virtual input interface as recited in claim 1, wherein said input accepting means accepts input in the form of menu selections.

7. The virtual input interface as recited in claim 1, wherein said at least one physical device can be removed from said system without affecting the operation of the remainder of said system.

8. The virtual input interface as recited in claim 1, wherein at least one additional physical device can be added to said system without affecting the operation of the remainder of said system.

9. A virtual output interface in a data processing system, said interface comprising:

a source of virtual input, said virtual input comprising one or more picture elements, each picture element comprising a plurality of device-independent data structures in a predetermined, standard data format, at least one of said data structures comprising a plurality of different data fields each containing information describing said picture element;

means for performing processing operations on said virtual input and for generating virtual output;

means for accepting said virtual output; and

means for converting said virtual output into at least one physical output suitable for use by at least one physical output device.

10. The virtual output interface as recited in claim 9, wherein said virtual input comprises a plurality of related picture elements and wherein said virtual output accepting means comprises a picture manager process for controlling said plurality of related picture elements.

11. The virtual output interface as recited in claim 10 and further comprising a display device, wherein said virtual output accepting means further comprises a window manager process for controlling the display of said plurality of related picture elements on said display device.

12. The virtual output interface as recited in claim 9, wherein said virtual output converting means comprises a virtual output manager process responsive to said one or more processed picture elements for coupling said one or more processed picture elements to said at least one physical output device.

13. The virtual output interface as recited in claim 9, wherein said at least one physical device can be removed from said system without affecting the operation of the remainder of said system.

14. The virtual output interface as recited in claim 9, wherein at least one additional physical device can be added to said system without affecting the operation of the remainder of said system.

15. In a data processing system, an interface between processes and data in said system and physical input and output devices coupled to said system, said interface comprising:

means responsive to one of said physical input devices for generating a picture, said picture comprising one or more picture elements, each picture element comprising a plurality of device-independent data structures in a predetermined, standard data format, at least one of said data structures comprising a plurality of different data fields each containing information describing said picture element;

means for performing processing operations on said one or more picture elements; and

means responsive to said one or more processed picture elements for coupling said one or more processed picture elements to one of said physical output devices.

16. The data processing system as recited in claim 15, wherein said one or more picture elements define a graphical object and at least one attribute thereof.

17. The data processing system as recited in claim 16, wherein one of said data fields describes the length of the associated picture element.

18. The data processing system as recited in claim 16, wherein one of said data fields identifies the particular type of the associated picture element.

19. The data processing system as recited in claim 16, wherein one of said data fields describes the position of the associated picture element relative to row and column coordinates on a picture of which said picture element forms a part.

20. The data processing system as recited in claim 16, wherein one of said data fields describes the size of the associated picture element.

21. The data processing system as recited in claim 16, wherein one of said data fields describes the color of the associated picture element.

22. The data processing system as recited in claim 15, wherein said means responsive to one of said physical input devices comprises a virtual input manager process.

23. The data processing system as recited in claim 15, wherein said means responsive to said one or more processed picture elements comprises a virtual output manager process.

* * * * *