

# **EXHIBIT 15**

Aug. 27, 1957

M. P. BRADFORD

2,803,845

CIRCULAR TOWEL

Filed June 14, 1954

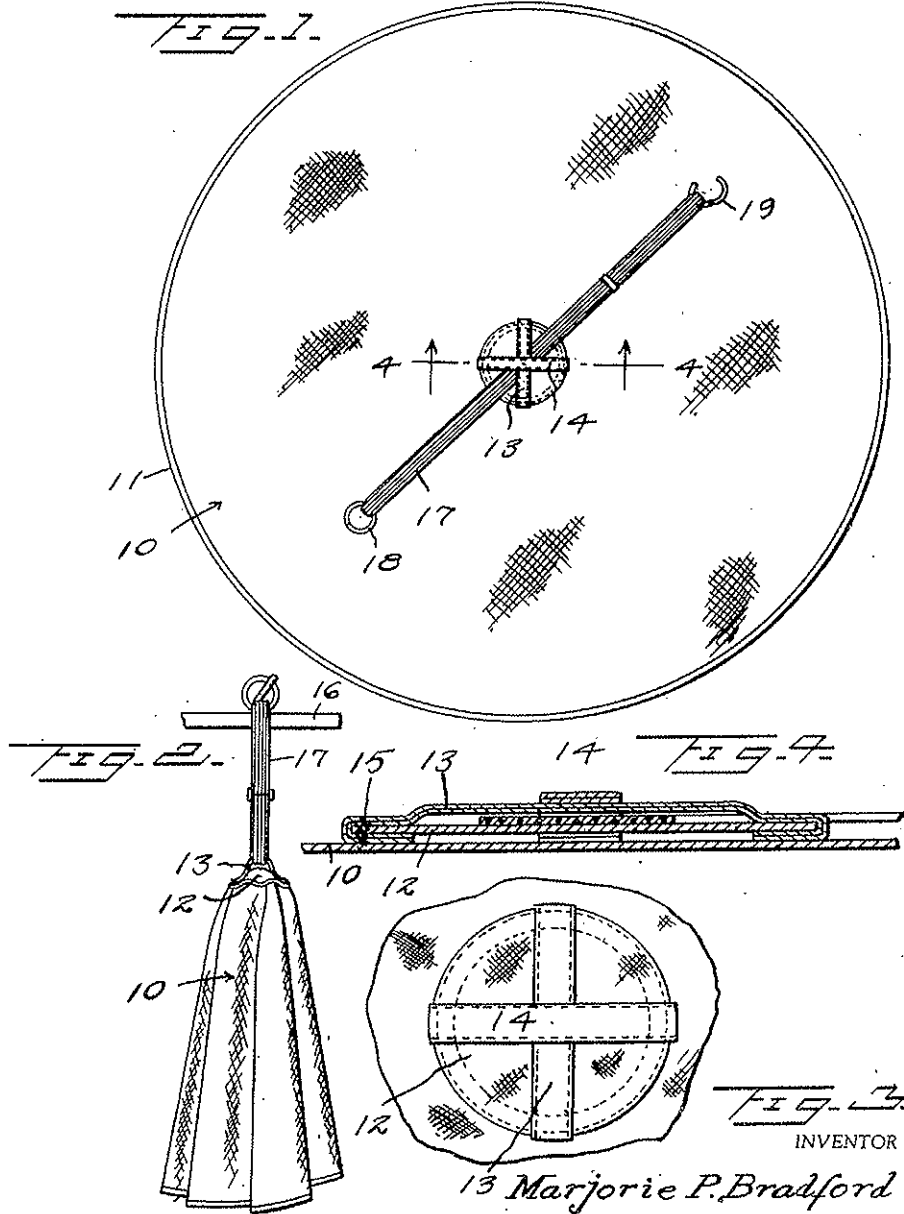

INVENTOR

13 Marjorie P. Bradford

BY *Kimmel + Crowell*  
ATTORNEYS

# United States Patent Office

2,803,845  
Patented Aug. 27, 1957

1

2,803,845

## CIRCULAR TOWEL

Marjorie Paschall Bradford, Dubuque, Iowa  
Application June 14, 1954, Serial No. 436,483  
1 Claim. (Cl. 15-209)

This invention relates to towels.

An object of this invention is to provide a towel which is constructed in circular form and includes means for suspending the same from a towel rack.

Another object of this invention is to provide a towel of the bath type having great area and including an elastic suspension element so that the towel may be disposed in a convenient position for use by small children. It is well known that small children are very careless in the use and handling of towels, and when they are through with the towels they either drop them on the floor or carelessly put the towels back on the rack. The result is that the bathroom is littered with towels which could be used again if carefully handled.

It is another object of this invention to provide an improved towel construction including an elastic strap or suspension element which is engaged about the towel rack so that pull on the towel during the use thereof will not place a strain on the towel rack.

A further object of this invention is to provide a towel of circular or disc shape with a central reinforcing disc and a pair of crossed straps through which an elastic band is extended so that no undue strain will be exerted on the towel or the rack.

With the above and other objects in view, my invention consist in the arrangement, combination and details of construction disclosed in the drawing and specification, and then more particularly pointed out in the appended claims.

In the drawing:

Figure 1 is a plan view of a towel constructed according to an embodiment of this invention showing the device in flat form.

Figure 2 is a detail side elevation of the towel in suspended form.

Figure 3 is a fragmentary plan view on an enlarged scale of the central portion of the towel.

Figure 4 is a fragmentary sectional view taken on the line 4-4 of Figure 1.

2

Referring to the drawing the numeral 10 designates generally a circular fabric which is hemmed as at 11 at its outer margin. The fabric 10 is constructed of conventional toweling such as used for bath towels and the body 10 in the center thereof has stitched thereto a disc-shaped reinforcing member 12. A pair of crossed straps 13 and 14 extend over the disc 12 and the outer ends of the straps 13 and 14 as shown in Figure 4 are extended about the outer margin of the disc 12 and then extended inwardly beneath the disc 12. The disc and the straps 13 and 14 are stitched to the body 10 as by stitching 15.

In order to provide a means whereby the circular body may be suspended from a towel rack bar 16, I have provided an elongated elastic strap 17. The strap 17 is extended beneath the crossed portions of the straps 13 and 14 as shown in Figure 1 and the ends of the elastic strap or band 17 are then provided with rings 18 and 19. At least one of these rings such as ring 19 is of the separable type so that ring 19 may be locked to ring 18 with the strap or band 17 extended over and about the supporting bar 16.

The circular form of the towel body 10 provides a relatively large area of toweling for use by small children and by suspending the body 10 with an elastic strap or band the tapes 13 and 14 will not be placed under undue tearing strain if the towel is pulled laterally or downwardly with respect to the rack bar 16.

When the body 10 is being laundered, the elastic strap 17 may be removed from the towel so that the elastic strap will not deteriorate too quickly by reason of becoming wet.

What is claimed is:

In combination, a towel and suspension means therefor comprising, a circular fabric body, a reinforcing disc for said body, a pair of crossed straps positioned on said disc with the ends of said straps extending under the edge of said disc, stitching extending through said body, said disc and said straps securing said body, said disc and said straps together, with said disc disposed centrally of said body, an adjustable elastic suspension member extending under said crossed straps for suspending said body, and means joining the opposite ends of said elastic suspension member to form a closed loop.

### References Cited in the file of this patent

#### UNITED STATES PATENTS

1,351,311	Virneburg	Aug. 31, 1920
1,478,112	Flather	Dec. 18, 1923
2,204,947	Apfelbaum	June 18, 1940
2,288,469	Lookholder	June 30, 1942
2,754,532	Kanehl	July 17, 1956