

Exhibit Q

Part 1



US007536167B2

(12) **United States Patent**
Gollnick et al.

(10) **Patent No.:** **US 7,536,167 B2**
(45) **Date of Patent:** ***May 19, 2009**

(54) **NETWORK SUPPORTING ROAMING,
SLEEPING TERMINALS**

(75) Inventors: **Charles D. Gollnick**, Cedar Rapids, IA (US); **Ronald E. Luse**, Marion, IA (US); **John G. Pavek**, Cedar Rapids, IA (US); **Marvin L. Sojka**, Cedar Rapids, IA (US); **James D. Cnossen**, Marion, IA (US); **Arvin D. Danielson**, Cedar Rapids, IA (US); **Ronald L. Mahany**, Cedar Rapids, IA (US); **Mary L. Detweiler**, Parnell, IA (US); **Gary N. Spiess**, Lisbon, IA (US); **Guy J. West**, Cedar Rapids, IA (US); **Amos D. Young**, Cedar Rapids, IA (US); **Robert C. Meier**, Cedar Rapids, IA (US); **Keith K. Cargin, Jr.**, Cedar Rapids, IA (US); **Richard C. Arensdorf**, Ely, IA (US); **Robert G. Geers**, Cedar Rapids, IA (US)

(73) Assignee: **Broadcom Corporation**, Irvine, CA (US)

(*) Notice: Subject to any disclaimer, the term of this patent is extended or adjusted under 35 U.S.C. 154(b) by 279 days.

This patent is subject to a terminal disclaimer.

(21) Appl. No.: **10/630,138**

(22) Filed: **Jul. 29, 2003**

(65) **Prior Publication Data**

US 2004/0023651 A1 Feb. 5, 2004

Related U.S. Application Data

(63) Continuation of application No. 09/318,668, filed on May 25, 1999, which is a continuation of application No. 08/545,108, filed on Oct. 19, 1995, now Pat. No. 5,940,771, which is a continuation of application No. 07/947,102, filed on Sep. 14, 1992, now abandoned,

and a continuation of application No. 07/907,927, filed on Jun. 30, 1992, now abandoned, said application No. 07/947,102 and a continuation-in-part of application No. 07/857,603, filed on Mar. 30, 1992, now abandoned, is a continuation-in-part of application No. 07/700,704, filed on May 14, 1991, now abandoned, which is a continuation-in-part of application No. 07/699,818, filed on May 13, 1991, now abandoned, said application No. 07/907,927 and a continuation-in-part of application No. PCT/US92/03982, filed on May 13, 1992, and a continuation-in-part of application No. 07/769,425, filed on Oct. 1, 1991, now abandoned, and a continuation-in-part of application No. 07/802,348, filed on Dec. 4, 1991, now abandoned, is a continuation-in-part of application No. 07/790,946, filed on Nov. 12, 1991, now abandoned.

- (51) **Int. Cl.**
H04W 52/44 (2006.01)
H04W 52/28 (2006.01)
- (52) **U.S. Cl.** **455/343.4**; 455/412.2; 455/517; 455/574
- (58) **Field of Classification Search** 455/343.1-6, 455/517, 561, 412.2, 574
See application file for complete search history.

(56) **References Cited**

U.S. PATENT DOCUMENTS

3,781,815	A	12/1973	Boudreau et al.
4,164,628	A	8/1979	Ward et al.
4,332,027	A	5/1982	Malcom et al.
4,414,661	A	11/1983	Karlstrom
4,449,248	A	5/1984	Leslie et al.
4,630,314	A	12/1986	Smith
4,644,532	A	2/1987	George et al.
4,663,706	A	5/1987	Allen et al.
4,679,244	A	7/1987	Kawasaki et al.
4,725,992	A	2/1988	McNatt et al.
4,734,694	A	3/1988	Umetsu et al.
4,736,461	A	4/1988	Kawasaki et al.
4,745,408	A	5/1988	Nagata et al.
4,747,126	A	5/1988	Hood et al.
4,748,658	A	5/1988	Gopal et al.
4,794,649	A	12/1988	Fujiwara

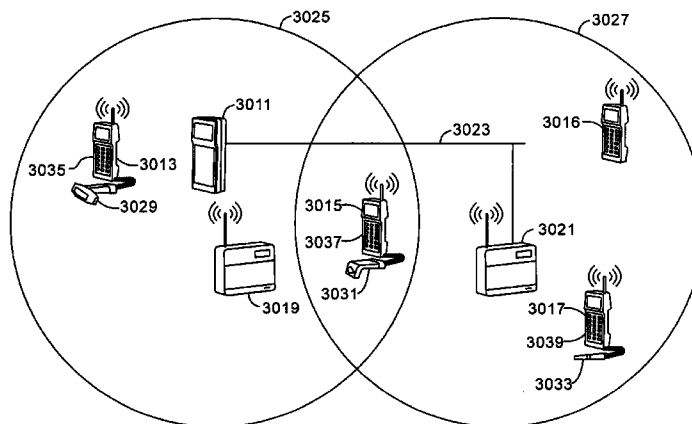

4,799,253 A	1/1989	Stern et al.	5,275,254 A	1/1994	Shiraishi et al.
4,804,954 A	2/1989	Macnak	5,276,680 A	1/1994	Messenger
4,809,257 A	2/1989	Gantenbein et al.	5,278,831 A	1/1994	Mabey
4,837,858 A	6/1989	Ablay et al.	5,280,480 A	1/1994	Pitt et al.
4,857,915 A	8/1989	Andros et al.	5,285,208 A	2/1994	Bertiger
4,864,559 A	9/1989	Perlman	5,291,479 A	3/1994	Vaziri et al.
4,884,266 A	11/1989	Pflaumer	5,293,639 A	3/1994	Wilson
4,885,780 A	12/1989	Gopal et al.	5,295,154 A	3/1994	Meier et al.
4,903,319 A	2/1990	Kasai et al.	5,296,849 A	3/1994	Ide
4,916,726 A	4/1990	Morley, Jr. et al.	5,297,144 A	3/1994	Gilbert
4,926,064 A	5/1990	Tapang	5,301,225 A	4/1994	Suzuki et al.
4,942,552 A	7/1990	Merrill et al.	5,329,531 A	7/1994	Diepstraten et al.
4,964,121 A	10/1990	Moore	5,329,576 A	7/1994	Handforth
4,977,611 A	12/1990	Maru	5,331,634 A	7/1994	Fischer
4,984,247 A	1/1991	Kaufmann et al.	5,343,512 A	8/1994	Wang
4,989,230 A	1/1991	Gillig	5,361,397 A	11/1994	Wright
4,995,099 A	2/1991	Davis	5,371,734 A	12/1994	Fischer
5,008,882 A	4/1991	Peterson et al.	5,371,898 A	12/1994	Grube et al.
5,018,133 A	5/1991	Tsukakoshi et al.	5,373,506 A	12/1994	Taylor
5,025,486 A	6/1991	Klughart	5,375,254 A	12/1994	Owen
5,027,427 A	6/1991	Shimizu	5,377,192 A	12/1994	Goodings et al.
5,027,428 A	6/1991	Ishiguro et al.	5,390,206 A	2/1995	Rein
5,029,183 A	7/1991	Tymes	5,392,023 A	2/1995	D'avello
5,031,098 A	7/1991	Miller et al.	5,392,287 A	2/1995	Tiedemann, Jr. et al.
5,031,231 A	7/1991	Miyazaki	5,394,436 A	2/1995	Meier et al.
5,055,659 A	10/1991	Hendrick et al.	5,420,911 A	5/1995	Dahlin et al.
5,056,085 A	10/1991	Vu	5,425,051 A	6/1995	Mahany
5,058,023 A	10/1991	Kozikaro	5,440,560 A	8/1995	Rypinski
5,058,203 A	10/1991	Inagami	5,461,627 A	10/1995	Rypinski
5,081,402 A	1/1992	Koleda	5,465,081 A	11/1995	Todd
5,087,099 A	2/1992	Stolarczyk	5,504,476 A	4/1996	Marrs et al.
5,089,813 A	2/1992	Deluca	5,509,035 A	4/1996	Teidemann, Jr. et al.
5,093,926 A	3/1992	Sasuta	5,533,097 A	7/1996	Crane
5,099,509 A	3/1992	Morganstein et al.	5,550,895 A	8/1996	Burson
5,103,459 A	4/1992	Gilhousesen et al.	5,581,173 A	12/1996	Yalla et al.
5,103,461 A	4/1992	Tymes	5,584,048 A	12/1996	Wieczorek
5,117,422 A	5/1992	Hauptschein et al.	5,590,346 A	12/1996	West et al.
5,117,449 A	5/1992	Metroka	5,649,308 A	7/1997	Andrews
5,119,397 A	6/1992	Dahlin et al.	5,680,311 A	10/1997	Trsar et al.
5,119,502 A	6/1992	Kallin et al.	5,696,468 A	12/1997	Nise
5,121,408 A	6/1992	Cai et al.	5,708,680 A	1/1998	Gollnick et al.
5,123,029 A	6/1992	Bantz	5,712,868 A	1/1998	Stern
5,128,932 A	7/1992	Li	5,740,366 A	4/1998	Mahaney et al.
5,128,938 A	7/1992	Borras	5,745,523 A	4/1998	Dent et al.
5,134,347 A	7/1992	Koleda	5,757,239 A	5/1998	Gilmore
5,142,279 A	8/1992	Jasinski et al.	5,825,253 A	10/1998	Mathe et al.
5,142,531 A	8/1992	Kirby	5,828,695 A	10/1998	Webb
5,142,534 A	8/1992	Simpson et al.	5,844,893 A	12/1998	Gollnick et al.
5,142,550 A	8/1992	Tymes	5,910,752 A	6/1999	Filipovic et al.
5,146,214 A	9/1992	Yamada et al.	5,940,771 A	8/1999	Gollnick et al.
5,150,360 A	9/1992	Perlman et al.	6,046,992 A	4/2000	Meier et al.
5,150,361 A	9/1992	Wieczorek et al.	6,069,880 A	5/2000	Owen et al.
5,152,006 A	9/1992	Klaus	6,348,841 B1	2/2002	See
5,157,687 A	10/1992	Tymes	6,359,872 B1	3/2002	Mahany et al.
5,159,592 A	10/1992	Perkins	6,374,311 B1	4/2002	Mahany et al.
5,163,080 A	11/1992	Amoroso et al.	6,522,871 B1	2/2003	Patrick et al.
5,168,271 A	* 12/1992	Hoff 455/343.4 X	6,583,675 B2	6/2003	Gomez
5,168,498 A	12/1992	Adams	6,593,826 B2	7/2003	See
5,175,870 A	12/1992	Mabey	6,694,129 B2	2/2004	Peterzell et al.
5,203,020 A	4/1993	Sato et al.	6,714,983 B1	3/2004	Koenck et al.
5,224,150 A	6/1993	Neustein	6,731,146 B1	5/2004	Gallardo
5,224,152 A	6/1993	Harte	6,764,983 B1	7/2004	Hammond et al.
5,230,084 A	7/1993	Nguyen	6,819,197 B2	11/2004	Maldonado
5,239,466 A	8/1993	Morgan	6,823,033 B2	11/2004	Fahim
5,241,542 A	8/1993	Natarajan et al.	6,888,913 B2	5/2005	Walker
5,241,691 A	8/1993	Owen	6,911,856 B2	6/2005	Florescu
5,252,963 A	10/1993	Snowden et al.	6,928,275 B1	8/2005	Patrick et al.
5,255,268 A	10/1993	Cato et al.	6,937,872 B2	8/2005	Krasner
5,257,019 A	10/1993	Schwendeman et al.			
5,260,988 A	11/1993	Schellinger et al.			
5,260,990 A	11/1993	MeLampy et al.			
5,265,270 A	11/1993	Stengel			
5,274,666 A	12/1993	Dowdell et al.			

FOREIGN PATENT DOCUMENTS

EP	0 490 441 A2	6/1992
EP	281334	1/1995

GB	2250892	6/1992
JP	61-174743	8/1986
JP	62-37008	8/1994
WO	WO 92/02084	2/1992
WO	WO-9202084	2/1992

OTHER PUBLICATIONS

- "A 1.6-3.2 GHz, High Phase Accuracy Quadrature Phase Locked Loop", Masters Thesis, Department Of Electrical Engineering And Computer Science, Mass. Inst. Of Technology, Jun. 2003.
- Digital And Ericsson Agree On Data Network Project, Wall Street Journal, Oct. 8, 1991, p. B4.
- "Messenger User Guide", Cognito Limited, Apr. 1991.
- "Standards: Ericsson", Communications International 1991, Sep. 1991, p. 46.
- Posthearing Brief Of The Commission Investigative Staff, United States International Trade Commission, Apr. 3, 2006.
- Joifaei et al., "Concept Of On-Board-Processing Satellites", IEEE—ICUPC '92 Proceedings, Sep. 29, 1992-Oct. 2, 1992, pp. 391-394.
- Seshadri et al., "Coded Modulation With Time Diversity, Unequal Error Protection, And Low Delay For The Rayleigh Fading Channel", IEEE—ICUPE '92 Proceedings, Sep. 29, 1992-Oct. 2, 1992, pp. 283-287.
- Slimane et al., "Coded Quadrature Pulse-Overlapping Modulation Techniques For Personal Communications", IEEE—ICUPC '92 Proceedings, Sep. 29, 1992-Oct. 2, 1992, pp. 293-297.
- Wang, "Coded BER Performance In A Correlative Fading Channel", IEEE—ICUPC '92 Proceedings, Sep. 29, 1992-Oct. 2, 1992, pp. 126-130.
- "Ericsson Wins Mobile Data Pact", Communications Week International, Jun. 26, 1989, No. 21, p. 13.
- Rohl, A Short Look on Power Saving Mechanisms In The Wireless LAN Standard Draft IEEE Standard 802.11, Jun. 26, 1997, Bates No. QBB218363-368.
- "Man-Machine Interface Of The Mobile Station", GSM 03.30 v. 3.9.0, Feb. 1992, QBB155113-155137.
- "Waiting Time For Wireless", Computerworld, Oct. 15, 1990, pp. 73-75.
- "Update On Ardis-Mobitex Radio Modem Competition", Newsbyte News Network, Oct. 2, 1991.
- MS-BSS Interface—General Aspects And Principles, GSM 04.01 v 3.0.01, Feb. 1992, QBB155196-155206.
- Network Functions, GSM 03.01 v 3.0.0, Feb. 1992, QBB155138-155152.
- Robert Meier Deposition Transcript, Nov. 18, 2005.
- Steven Koenck Deposition Transcript, Nov. 15, 2005.
- Technical Manual Callmaster IMTS Series: MT-200 & MT-300, 1982.
- Ericsson—Company Report: Svenska International PLC', Ericsson Company Report, Svenska International PLC, Investext Report No. 1152645, Nov. 15, 1991, p. 2.
- CALHOUN, Wireless Access and the Local Telephone Network, 1992.
- Respondent Qualcomm Incorporated's Notice Of Prior Art, with Exhibits A & D attached thereto, Nov. 15, 2005.
- Qualcomm's Response To Interrogatory 3, with Exhibits B & C attached thereto, Nov. 15, 2005.
- Intentionally Left Blank.
- "A New Chapter In Wireless Communication And Email", Electronic Messaging News, Nov. 27, 1991, vol. 3, No. 24.
- "AMDC Extends RFP Deadline To March 10; Waiver Decision Expected At FCC's March Meeting", Industrial Communications, Feb. 17, 1989, No. 7.
- "An Effective Prioritization Scheme For Handovers In Cellular Networks", IEEE—ICUPC '92 Proceedings, Sep. 29, 1992-Oct. 2, 1992, pp. 364-368.
- "Ardis Links With NCR Notepad Dec. 11, 1991", Newsbytes, Dec. 11, 1991.
- "Ardis To Face Competition From RAM", Newsbytes, Feb. 5, 1991.
- "Automation In Warehousing", Proceedings Of The 8th International Conference, Tokyo, Japan, Oct. 6-8, 1987, pp. 1-355.
- "Autonomous Radio Stations Possible Over Mobitex", Industrial Communications, Dec. 9, 1988, No. 48.
- "Bean Bullish On Growth Of Mobile Data In New Future", Industrial Communications, Feb. 15, 1991, No. 7, p. 8.
- "Bellsouth Buys Into Ram's Nationwide Mobile Data Network", Industrial Communications, Oct. 18, 1991, No. 42.
- "BellSouth Has Option To Buy RAM Oct. 11, 1991", Newsbytes, Oct. 11, 1991.
- "BellSouth RAM In Joint Venture", BOC Week, Oct. 21, 1991, vol. 8, No. 40, p. 12.
- "Bellsouth, RAM To Form Mobile Communications Joint Venture", PR Newswire, Oct. 10, 1991, p. 1.
- Briefing Document For The Design Of The Diplema Messenger MMI, Mar. 1989.
- "Broadband Lan Technology", 1988.
- "Canadian Cellular Industry (the)—Industry Report", First Marathon Securities Ltd. Industry Report, Oct. 25, 1991, Investext Report No. 1154903, p. 30.
- "Cantel To Launch Mobile-Data And Paging Networks", The Gazette, Montreal Quebec, May 10, 1989, p. D1.
- "CDMA Digital CAI Standard, Cellular System Dual-Mode Mobile Station-Base Station Compatability Standard, Draft Rev. 0", Jul. 31, 1990, Bates Nos. QBB138614-832.
- "CDMA Digital CAI Standard, Cellular System Dual-Mode Mobile Station-Base Station Compatability Standard, Draft Rev. 1", Oct. 1, 1990, Bates Nos. QBB138833-9249.
- "CDMA Digital CAI Standard, Cellular System Dual-Mode Mobile Station-Base Station Compatability Standard, Draft Rev. 1.1", Jul. 15, 1991, Bates Nos. QBB139250-858.
- "Cellular System Dual-Mode Mobile Station—Base Station Compatability Standard", EIA/TIA Interim Standard, May 1990, IS-54.
- "Cellular System Mobile Station—Land Station Compatibility Specification", Office Of Science Technology Bulletin No. 53, Jul. 1983.
- "Change Request 05.02-11", Recommendation GSM 05.02, v. 3.3.0, Jun. 22, 1989.
- "Change Request 05.02-14", Recommendation GSM 05.02, v. 3.3.0, Nov. 28, 1989.
- "Coded First To Jump On Mobitex Equipment Bandwagon; Sees Data Licenses As Worth As Much As Cellular", Industrial Communications, Jun. 9, 1989, No. 22.
- "Communications Personals", Communications Daily, Feb. 11, 1991, vol. 11, No. 28.
- "Complexity, High Price Keep Some Customers Away: Mobile Datacoms Taxes Users", Communications Week International, Apr. 1, 1991, p. 20.
- "Consolidation, New Ventures Going Full Speed Ahead In All Markets", Industrial Communications, Oct. 6, 1989, No. 36, p. 1.
- "Covering Note To Draft Rec. GSM 01.04 Version 2.00.01—Vocabulary In A GSM PLMN", GSM 01.04 v. 2.00.01, Sep. 28, 1990.
- "Cutting The Ties That Bind", InformationWeek, Apr. 1, 1991, vol. 314, pp. 25-30.
- "DEC On Move: Teaming With Ericsson In Mobile Data Market", Communications Week International, Mar. 18, 1991, p. 1.
- "DEC Targets Mobile Data Market", Communications Week International, Mar. 18, 1991, p. 9.
- "Descriptive Air Interface Protocol", Cognito Group Limited, V. 6.0, Aug. 19, 1991.
- "Discontinuous Reception (DRX) in the GSM System", Recommendation GSM 03.13, v 3.0.2, Jan. 15, 1990.
- "Editorial: Telecom Trends", Newsbyte News Network, Dec. 24, 1991.
- "Ericsson—Company Report First Boston Corporation (The)", Jun. 10, 1988, Investext Report No. 813838, p. 9.
- "Ericsson—Company Report: Hoare Govett Investment Research Ltd", Oct. 1, 1990, Investext Report No. 1039045, p. 22.
- "Ericsson—Company Report: Prudential Securities Inc.", Mar. 19, 1990, Investext Report No. 1001955, p. 10.
- Ericsson—Company Report: Svenska International PLC', Ericsson Company Report, Svenska International PLC, Investext Report No. 1142535, Oct. 4, 1991, p. 2.

- "Ericsson (L.M.) (Telefon A/B)—Company Report: FT Analysis", Ericsson (L.M.) (Telefon A/B) Company Report FT Analysis, Investext Report No. 6027183, Nov. 19, 1991, p. 3.
- "Ericsson And Digital Cooperate On Mobile Communications", Newsbyte News Network Oct. 8, 1991, Newsbytes, Oct. 8, 1991.
- "Ericsson And Digital Cooperated In Mobile Data", Business Wire, San Francisco, Oct. 7, 1991, p. 1.
- "Ericsson And GE And Speedwing Mobile Communications Team Up To Bring Mobile Data Communications To Airports Worldwide", Business Wire, San Francisco, Sep. 17, 1991, p. 1.
- "Ericsson And GE Have Formed Joint Venture", Communications Daily, Aug. 28, 1989.
- "Ericsson Announces Communications Software", Industrial Communications, Mar. 1, 1991, No. 9.
- "Ericsson GE And Melard Technologies Announce A Strategic Alliance In Mobile Data Communications", Business Wire, San Francisco, Sep. 30, 1991, p. 1.
- "Ericsson GE And Racotek Announce A Strategic Relationship For Mobile Data Communications", Business Wire, San Francisco, Sep. 16, 1991, p. 1.
- "Ericsson GE And Racotek Inc. In Marketing Supply Deal", Alliance Alert-Medical Health, vol. 2, No. 10, Oct. 1, 1991.
- "Ericsson GE And Speedwing Mobile Commun In Marketing Supply Deal", Alliance Alert-Medical Health, Oct. 1991, vol. 2, No. 10.
- "Ericsson GE Awarded \$11.6 Million Contract From The U.S. Navy", Business Wire, San Francisco, Nov. 10, 1993, p. 1.
- "Ericsson GE Awarded Contract From The City Of Richardson, Texas", Business Wire, San Francisco, Oct. 1, 1991, p. 1.
- "Ericsson GE In Development Deal With Anterior And RIM", Newsbyte News Network, Nov. 20, 1991.
- Ericsson GE In Joint Ventures To Develop Wireless E-Mail, Telecommunications Alert, Nov. 19, 1991, vol. 8, No. 38.
- "Ericsson GE Mobile Communications New R&D Center Begins Operations In North Carolina", Business Wire, San Francisco, Nov. 27, 1990, p. 1.
- "Ericsson GE Mobile Communications Opens Research And Development Center In North Carolina", Business Wire, San Francisco, May 1, 1990, p. 1.
- "Ericsson GE Mobile Communications To manage Its Worldwide Cellular Telephone Business From RTP, N.C.", Business Wire, San Francisco, Apr. 24, 1991, p. 1.
- "Ericsson GE Mobile Data And BRM Mobile Data Sign Agreements With GE Consumer Service", News Release, Jul. 25, 1991, p. 1.
- "Ericsson GE Mobile Data And RAM Mobile Data Sign Agreements With GE Consumer Services", Business Wire, San Francisco, May 9, 1991, p. 1.
- "Ericsson GE, Anterior Technology & Research In Motion (RIM)—Announce Wireless Access For E-Mail Users", News Release, Nov. 18, 1991, p. 1.
- "Ericsson Gets \$55M Pact for Cellular Radio Data Gear", Electronic News (1991), p. 19, Jun. 12, 1989.
- "Ericsson Has Data Unit" Communications Week, Jan. 8, 1990, p. 8.
- "Ericsson Mobile Data Formed In New Jersey", Communications Daily, Jan. 5, 1990.
- "Ericsson Signs \$55 Million Agreement With RAM Broadcasting For Mobile Data Network", Industrial Communicaitons, Jun. 2, 1989, No. 20.
- "Ericsson To Introduce Radio Modem Next Month", Telecommunications Alert, Dec. 17, 1991, vol. 8, No. 56.
- "Ericsson/GE Announces New Agreements", Industrial Communications, Oct. 4, 1991, No. 40.
- "Ericsson: Breakthrough \$55 Million Agreement For Mobile Data Network In U.S.A.", Edge, Jun. 12, 1989, vol. 4, No. 64.
- "Ericsson's Mobitex Mobile Data System Is Chosen By Cantel For Nationwide Public Mobile Data Service In Canada", News Release, Ericsson (LM) Telephone, Dec. 1, 1988, p. 1.
- "European Digital Cellular Telecommunications System (Phase 2), Discontinuous Reception (DRX) In The GSM System", GSM 03.13, v. 4.0.1, Jul. 1, 1993.
- "European Digital Cellular Telecommunications System (Phase 2), Functions Related To MS In Idle Mode", GSM 03.22, Version 4.4.0, Jun. 25, 1993.
- "European Digital Cellular Telecommunications System (Phase 2), Mobile Stations (MS) Features", GSM 02.07, Oct. 1993.
- "European Digital Cellular Telecommunications System (Phase 2), Mobile Stations Features", GSM 02.07, v. 4.4.1, Jun. 7, 1993.
- "FCC Calendar Of Events For The Week Of February 11", FCC Daily Digest, Feb. 8, 1991, vol. 10, No. 27.
- "IBM, Motorola Join Networks Forming 2-Way Data Offering", Industrial Communications, Feb. 2, 1990, No. 5, p. 1.
- "Industry Briefs", Network World, Oct. 14, 1991, vol. 8, No. 41, pp. 9, 11.
- Lead Story #2: Swedish Government Picks Magnovox AVL For Upcoming Trials, Inside IVHS, Feb. 4, 1991, vol. 1, No. 3.
- "Man-Machine Interface Of The Mobile Station", Recommendation GSM 02.30, v 3.5.0, Mar. 1990.
- "Mobidata And Cantel Set To Complete In Digital Mobile Data Market", Common Carrier Week, May 22, 1989, vol. 6, No. 21.
- "Mobile Data Communications—A New Market", News Release, Jul. 3, 1987, p. 1.
- "Mobile Data Communications: Erickson GE & Racotek In Strategic Relationship", Edge, Sep. 23, 1991, vol. 6, No. 165, p. 6.
- "Mobile Data Communications: Ericsson GE & Racotek In Strategic Relationship", Edge, Sep. 23, 1991, vol. 2, No. 70, p. 21.
- "Mobile Move", CommunicationsWeek International, Nov. 4, 1991, No. 73, p. 3.
- "Mobile Station Features", Recommendation GSM 02.07, v. 3.4.0, Jan. 1991.
- "Mobile Station Features", Recommendation GSM 02.07, v 3.3.0, Mar. 1990.
- "Mobile Users Get Electronic Mail Link (Anterior Technology)", Communications International, Dec. 13, 1991, No. 1823, CG11210016.
- "MS-BSS Interface Date Link Layer Specification", Recommendation GSM 04.06, v. 3.6.0, Nov. 1990.
- "MTEL WOOS FCC For Two-Way Data Net At 930-931 MHz", Industrial Communications, No. 47, Nov. 22, 1991.
- "Multi-Channel Land Mobile Systems For Dispatch Traffic (With Or Without PSTN Interconnection)", ITU-R—International Telecommunication Union/ITU Radiocommunication Sector, 1990, Report No. 741-3, pp. 142-153.
- "Multiplexing And Multiple Access On The Radio Path", GSM Recommendation 05.02, v. 3.4.1, Jan. 1990.
- "National Car Rental Chooses RAM For Data Network Services", Industrial Communications, VIS24, Jun. 14, 1991.
- "National Mobile Data Network Sends Out Request For Information; Dream System In Mind Already", Industrial Communications, Oct. 21, 1988.
- "Noise-Free Data Nets Introduced", Telecommunications Alert, Jul. 1990, vol. 8, No. 7.
- "Nokia—Line Of Business Classification", Annual Report, 1987.
- "Nordic Monthly—Geographic Report: Svenska International PLC", Oct. 1, 1991, Investext Report No. 1142734, p. 6.
- "Northern Indiana Public Service Company Selects \$10 Million Ericsson GE Communications System", News Release, Nov. 11, 1991, p. 1.
- "Other Manufactures Developing Compatible Hardware", Industrial Communications, Dec. 9, 1988, No. 48.
- "Outline Of Idle Mode Tasks, GSM Recommendation" 03.22, v. 1.0.1, May 23, 1991.
- "Physical Layer On The Radio Path: General Description", Change Request 05.02-2, Recommendation GSM 05.01, v. 3.3.0, Nov. 17, 1989.
- "Programme Management Review, GSM Action Plan, Review 18" ETSI/GSM 23, Jun. 5, 1989.
- "Programme Management Review; GSM Action Plan, Review 18", GSM 243/89, Jun. 5, 1989.
- "Proposed EAI,TIA Standard, Cellular System CDMA-Analog Dual-Mode Mobile Station—Base Station Compatibility Standard, Rev. 1.12", Mar. 16, 1992.
- "Proposed EAI,TIA Standard, Cellular System CDMA-Analog Dual-Mode Mobile Station—Base Station Compatibility Standard, Rev. 1.13", Mar. 23, 1992.

- "Proposed EIA/TIA Interim Standard, Wideband Spread Spectrum Digital Cellular System Dual-Mode Mobile Station—Base Station Compatibility Standard", EIA/TIA/IS-95, Apr. 21, 1992.
- "Radio-Linked Network To Be Offered To Airlines Sep. 19, 1991", Newsbytes, Inc., Sep. 19, 1991.
- "RAM Adds Customers To Mobile Data Network", Industrial Communications, Apr. 5, 1991, No. 14.
- "RAM Mobile Data And Ericsson GE Mobile Data Announce Agreements With Sears Business Centers", News Release, Mar. 26, 1991, p. 1.
- "RAM Mobile Data Launches Network With Transcontinental Message", News Release, Feb. 20, 1991, p. 1.
- "Ram Signs GE Consumer Service To A Pilot Test On its Data Network", Industrial Communications, May 10, 1991, No. 19.
- "Sales Decline: Ericsson 9-Month Net Off 53%", Electronic News, 1991, vol. 37, Issue 18.
- "Sears Business Centers To Market RAM's Mobile Data Network", Industrial Communications, Mar. 29, 1991, No. 13.
- "Sears Inks Pacts With Ericsson, RAM Mobile Data", Computer Reseller News, Apr. 29, 1991, 102, Issue 418, p. 1-2.
- "Security Related Network Functions", Recommendation GSM 3.20, v. 3.3.2, Jan. 1991.
- "Service", Industrial Communications, Dec. 9, 1988, No. 48.
- "SIM, Functional Characteristics", Recommendation GSM 02.17, v. 3.2.0, Mar. 1990.
- "Simware And Ram Mobile Data Network Sign Strategic Marketing Agreement", News Release, Oct. 7, 1991, p. 1.
- "Smith Barney's Morning Call—Topical Report Smith Barney, Harris Upham & Co.", Investext Report, No. 1145237, Oct. 11, 1991, p. 3.
- "Strategic Agreement: Simware & Ericsson GE In Strategic Marketing Agreement For Laptop Computer Access To Corporate Mainframes", Edge, Oct. 21, 1991, vol. 6, No. 169, p. 17.
- "Supporting Research And Advanced Development", NASA Space Programs Summary 37-48, vol. III, Jet Propulsion Laboratory, Dec. 31, 1967, pp. 1-291.
- "Sweden Launches The World's First Public Radio Telecommunication Network For Text, Speech And Data", Newswire, Trade Publication, Industrial News Service, Feb. 24, 1987.
- "Swedish Road Administration To Try Out Vehicle Location System", Industrial Communications Trade Publication, Apr. 5, 1991, No. 14.
- "Swedish Telecom Mobitex System Eases Mobile Frequency Congestion", Communications News, Apr. 1985, vol. 22, No. 4, p. 135.
- "The Messenger MMI Specification", Mar. 1990.
- "The Mobitex Packet-Switched Radio Data System", IEEE, Jul. 1992, pp. 534-538.
- "The OSPF Specification", Oct. 1989.
- "Third-Quarter Losses Prompt Sizable Ericsson Layoffs", Industrial Communications, Nov. 22, 1991, No. 47.
- Devasirvatham et al., "Two Frequency Radiowave Propagation Measurements In Brooklyn", IEEE—ICUPC '92 Proceedings, Sep. 29, 1992-Oct. 2, 1992, pp. 23-27.
- "U.K. Mobile Data Licenses Granted", Communications Week International, Feb. 26, 1990, No. 36, p. 18.
- "U.S. Army Selects Digitally Accessed Trunked Communications System For Training Centers", News Release, Oct. 1, 1991, p. 1.
- "Update On Ardis-Mobitex Radio Modem Competition", Newsbytes, Inc., Oct. 2, 1991.
- XIA et al., "Urban And Suburban Microcellular Propagation", IEEE—ICUPC '92 Proceedings, Sep. 29, 1992-Oct. 2, 1992, pp. 5-9.
- "Vandals Wreck Cardphones To Increase Booty From Payphones", Europe 2000—Communications & Information Technology, Sep. 1991, vol. 3, No. 7.
- "Vehicle Tracking And Communication Joint Venture", PRS Automotive Service, Aug. 22, 1991.
- "Why Did Ericsson Pick Up The Long-For-Sale GE Subsidiary?", Mobile Phone News, Aug. 31, 1989, vol. 7, No. 18.
- "Wireless Data: The Next Frontier For Cellular", Mobile Phone News, Dec. 5, 1991, vol. 9, No. 24, pp. 4-6.
- "Wireless World: Ericsson GE Enters Lockdown Matrix With Mobile Digital Telephone", Business Wire, San Francisco, Oct. 7, 1991, p. 1.
- "Wireless World: Ericsson GE In Lockdown Matrix With Mobile Digital Telephone", Edge, Oct. 7, 1991, vol. 6, No. 167, p. 29.
- "Wireless World: Ericsson GE, Anterior Technology & Research In Motion Announced Wireless Access For E-Mail Users", Business Wire, San Francisco, Nov. 18, 1991, p. 1.
- "Wireless World: Ericsson GE, Anterior Technology & Research In Motion (RIM) Announce Wireless E-mail", Edge, Nov. 25, 1991, vol. 6, No. 174, p. 4.
- "Year's Biggest Stories Land In Personal Communications, Spectrum (Part 1)", Industrial Communications, Jan. 4, 1991, No. 1.
- Abowd et al., "Cyberguide: A Mobile Context-Aware Tour Guide", Wireless Networks, 1997, vol. 3, pp. 421-433.
- Afek et al., "End-To-End Communication In Unreliable Networks", Proceedings Of The 7th Annual ACM Symposium On Principles Of Distributed Computing (Toronto, Ontario, Canada), 1988, pp. 131-148.
- Aguirre et al., "Signal Strength Measurements At 915 MHz and 1920 MHz In An October Microcell Environment", IEEE—ICUPC '92 Proceedings, Sep. 29, 1992-Oct. 2, 1992, pp. 16-22.
- Olmos et al., "Performance Analysis Of A Second Order Delay-Lock Loop With Application To A CDMA System With Multipath Propagation", IEEE—ICUPC '92 Proceedings, Sep. 29, 1992-Oct. 2, 1992, pp. 209-213.
- Akaiwa et al., "The Channel Segregation, A Self-Organized Dynamic Channel Allocation Method: Application to TDWA/FDMA Microcellular System", IEEE—ICUPC '92 Proceedings, Sep. 29, 1992-Oct. 2, 1992, pp. 345-349.
- Alfano et al., "UPT Supplementary Services European Standards Scenario", IEEE—ICUPC '92 Proceedings, Sep. 29, 1992-Oct. 2, 1992, pp. 69-73.
- Ameden, "Activities Of The Cellular Telecommunications Industry Association Microcell/Microsystems Subcommittee Regarding Microcell Technology", IEEE—ICUPC '92 Proceedings, Sep. 29, 1992-Oct. 2, 1992, pp. 147-150.
- Aoki, "Improved Output Spectrum Of Linearized Class-F Power Amplifier For Digital Cellular Mobile Communications", IEEE—ICUPC '92 Proceedings, Sep. 29, 1992-Oct. 2, 1992, pp. 195-198.
- Arndt et al., "International Standards On Universal Personal Telecommunications: State Of The Art And Future Projections", IEEE—ICUPC '92 Proceedings, Sep. 29, 1992-Oct. 2, 1992, pp. 59-63.
- Assarsson, "Technology, Know-How And Teamwork—The Vital Circle In A Ro-Ro Port", Report No. 0-904930-27-0, 1984, pp. 138-142.
- Badrinath et al., "Designing Distributed Algorithms For Mobile Computing Networks", Proceedings Of The Second Workshop On The Management Of Replicated Data Rutgers University, 1994, pp. 1-13.
- Badrinath et al., "To Send Or Not To Send: Implementing Deferred Transmission In Mobile Host", ICDCS, Hong Kong, Jun. 1996, pp. 1-7.
- Balakrishnan et al., "Improving Reliable Transport And Handoff Performance In Cellular Wireless Networks", Wireless Networks, 1995, vol. 1, pp. 469-481.
- Bart, "Vendors Join The Wireless Bandwagon", Communications International, Oct. 1991, vol. 18, No. 19, p. 25.
- Bartoli, "Group-Based Multicast And Dynamic Membership In Wireless Networks With Incomplete Spatial Coverage", Mobile Networks And Applications 3, 1998, pp. 175-188.
- Bean, "Paging At The Crossroads—Industry Report", Arthur D. Little Decision Resources, Inc., Jun. 27, 1990, Investext Report No. 1111592, pp. 5-6.
- Bedingfield, "On The Concept Of A Service Host For Personal Communications Services", IEEE—ICUPC '92 Proceedings, Sep. 29, 1992-Oct. 2, 1992, IEEE—ICUPC '92 Proceedings, Sep. 29, 1992-Oct. 2, 1992, pp. 314-318.
- Berkman, "Ericsson Is Restructuring To Adapt To A Deregulated Global Market", Electronic Business, Jan. 21, 1991, vol. 17, No. 2, pp. 34-38.
- Berntson, "Mobitex—A New Network For Mobile Data Communications", Ericsson Review, 1989, vol. 66, Issue 1, p. 33, Bates Nos. QBB151463-151469.

- Biba, "A Hybrid Wireless MAC Protocol Supporting Asynchronous And Synchronous MSDU Delivery Services", IEEE 802.11/91-92, Sep. 1991.
- Binkley et al., "Authenticated Ad Hoc Routing At The Link Layer For Mobile Systems", Wireless Networks, 2001, vol. 7.
- Blankenhorn, PacTel Cellular Introduces Microcells In Los Angeles, Newsbytes, Inc., Oct. 2, 1991.
- Blazević et al., "Self-Organizing Wide-Area Routing", Proc. Of SCI, 2000, pp. 1-8.
- Boyer, "An Analytical Comparison Of Block Error Rate Performance For Wireline Data Modulation Standards In A Variably Fading Ricean Analog Cellular Channel", IEEE—ICUPC '92 Proceedings, Sep. 29, 1992-Oct. 2, 1992, pp. 121-125.
- Bragwad et al., "Advanced Intelligent Network Requirements For Personal Communications Services", IEEE—ICUPC '92 Proceedings, Sep. 29, 1992-Oct. 2, 1992, pp. 324-328.
- Brodsky, "Wireless Data Networks And The Mobile Workforce", Telecommunications, Dec. 1990, vol. 24, No. 12, p. 31.
- Brodsky, "Wireless MANs/WANs Offer 'Data To Go'", Business Communications Review Feb. 1991, vol. 21, No. 2, p. 45-51.
- Buck, "Tele-Trends—Industry Report, Donaldson, Lufkin & Jenrette Securities Corp.", Jun. 24, 1988, Investext Report No. 814739, p. 8.
- Bulusu et al., "Scalable coordination For Wireless Sensor Networks: Self-Configuring Localization Systems", Proceedings Of The 6th International Symposium On Communication Theory And Applications (ISCTA), Jul. 2001, pp. 1-6.
- Bushaus, "GE, Ericsson In Cellular Pact", Telephony's AM Report, Aug. 28, 1989, vol. 217, No. 10, p. 3.
- Cáceres et al., "Fast And Scalable Wireless Handoffs In Support Of Mobile Internet Audio, Mobile Networks And Applications 3, 1998, pp. 351-363.
- Cáceres et al., "The Effects Of Mobility On Reliable Transport Protocols", International Conference On Distributed Computing Systems, Nov. 1, 1993.
- Cáceres et al., "Improving The Performance Of Reliable Transport Protocols In Mobile Computing Environments", IEEE Journal On Selected Areas In Communications, Jun. 1995, vol. 13, No. 5, pp. 1-10.
- Calhoun, "Digital Cellular Radio", 1988.
- Callendar, "Standards For Global Personal Communications Services", IEEE—ICUPC '92 Proceedings, Sep. 29, 1992-Oct. 2, 1992, pp. 163-167.
- Campbell et al., "A Cellular IP Testbed Demonstrator", Center For Telecommunications Research, Columbia University, New York, 1999, pp. 1-4.
- Carpintero et al., "Requirements For The Interconnection Of Base Stations In A Wireless System", IEEE—ICUPC '92 Proceedings, Sep. 29, 1992-Oct. 2, 1992, pp. 141-146.
- Cellular Data Network Functional Specification Rev. 2.0.2, Oct. 5, 1992.
- Cellular Digital Packet Data System Specification Overview, Jan. 19, 1995.
- Cellular Digital Packet Data System Specification Preliminary Release 0.8—Book I, Mar. 19, 1993.
- Cellular Digital Packet Data System Specification Preliminary Release 0.8—Book II, Mar. 19, 1993.
- Cellular Digital Packet Data System Specification Preliminary Release 0.8—Book III, Mar. 19, 1993.
- Cellular Digital Packet Data System Specification Release 0.3 Preliminary Working Draft, Dec. 28, 1992.
- Cellular Digital Packet Data System Specification Release 0.8—Book 4IV, Mar. 19, 1993.
- Cellular Digital Packet Data System Specification Release 0.8—Book V, Mar. 19, 1993.
- Cellular Digital Packet Data System Specification Release 0.9—Preliminary Draft, N/A, Apr. 30, 1993.
- Cellular Digital Packet Data System Specification Release 1.0—Book II, Jul. 19, 1993.
- Cellular Digital Packet Data System Specification Release 1.0—Book III, Jul. 19, 1993.
- Cellular Digital Packet Data System Specification Release 1.0—Book IV, Jul. 19, 1993.
- Cellular Digital Packet Data System Specification Release 1.0—Book V, Jul. 19, 1993.
- Cellular Digital Packet Data System Specification Release 1.0—Book I, Jul. 19, 1993.
- Cellular Digital Packet Data System Specification Release 1.1—Book 2, 1995 CDPD Forum, Inc., Jan. 19, 1995.
- Cellular Digital Packet Data System Specification Release 1.1—Book 3, 1995 CDPD Forum, Inc., Jan. 19, 1995.
- Cellular Digital Packet Data System Specification Release 1.1—Book 4, 1995 CDPD Forum, Inc., Jan. 19, 1995.
- Cellular Digital Packet Data System Specification Release 1.1—Book 6, 1995 CDPD Forum, Inc., Jan. 19, 1995.
- Cellular Digital Packet Data System Specification Release 1.1—Book 7, 1995 CDPD Forum, Inc., Jan. 19, 1995.
- Cellular Digital Packet Data System Specification Release 1.1—Book 8, 1995 CDPD Forum, Inc., Jan. 19, 1995.
- Chang, "Dispersive Fading Effects In CDMA Radio Systems", IEEE—ICUPC '92 Proceedings, Sep. 29, 1992-Oct. 2, 1992, pp. 185-189.
- Change Request to Specification GSM 02.11 Service Accessibility GSM 02.11, v 4.4.0, Feb. 11, 1993.
- Chen et al., "Signaling System No. 7 Network Interconnect Impacts In Support Of Mobile Communications Services", IEEE—ICUPC '92 Proceedings, Sep. 29, 1992-Oct. 2, 1992, pp. 247-252.
- Chuang, "Frequency Reuse For Two Co-Existing TDMA Personal Communications Systems", IEEE—ICUPC '92 Proceedings, Sep. 29, 1992-Oct. 2, 1992, pp. 350-354.
- Ciancetta et al., "Universal Personal Telecommunication Provision Within Intelligent Networks", IEEE—ICUPC '92 Proceedings, Sep. 29, 1992-Oct. 2, 1992, pp. 319-323.
- Connolly, "Mobile Data Mission", Communications, Aug. 1990, vol. 27, No. 8, pp. 41-48.
- Coursey, Mobile Computing Matures: Radio Moderns Will Let Portables Send, Receive E-Mail, InfoWorld, 1991, vol. 13, Issue 51, p. 28.
- Craninckx et al., "Wireless CMOS Frequency Synthesizer Design", 1998.
- Cunningham, "Rascal Telecom—Company Report Scrimgeour Vickers", Feb. 17, 1989, Investext Report No. 908246, p. 4.
- Davis et al., "Filtered Spreading Sequences For Interference Avoidance", IEEE—ICUPC '92 Proceedings, Sep. 29, 1992-Oct. 2, 1992, pp. 54-58.
- Didner, "Data Goes Mobile", Telephony, Mar. 11, 1991, vol. 220, No. 10, pp. 24-25.
- Didner, "The Next Step In Mobile Communications", Telecommunications, Dec. 1990, vol. 24, No. 12, p. 48-50.
- Dommety et al., "Flat Location Management Scheme For PCNs", 1997.
- Dube et al., "Signal Stability Based Adaptive Routing (SSA) For Ad-Hoc Mobile Networks", IEEE Personal Communication, Aug. 26, 1996, pp. 1-22.
- Duet, "An Assessment Of Duplexing Methods For The Radio Links Of Personal Communication Systems", IEEE—ICUPC '92 Proceedings, Sep. 29, 1992-Oct. 2, 1992, pp. 131-135.
- Earnshaw, "The Topology Discovery Service", Feb. 18, 1993, pp. 11 1-11 8.
- Edwards, "Simware Targets Software AT RF Wireless Market", Computing Canada, Nov. 7, 1991, vol. 17, No. 23, p. 53.
- Egan et al., "City Of Dallas Fire Department Purchases \$4 Million Ericsson GE Communications System", Business Wire, San Francisco, Oct. 16, 1991.
- Egan et al., "Ericsson And GE Form Mobile Communications Joint Venture", Business Wire, San Francisco, Aug. 24, 1989, p. 1.
- Egan et al., "McCaw Cellular, LIN Broadcasting To Rebuild Cellular Systems In N.Y., N.J. Pacific Northwest With Ericsson GE Equipment", Business Wire, San Francisco, Oct. 3, 1990, p. 1.
- Egan et al., "SaskTel Purchases New Ericsson GE Communications System To Serve Saskatchewan", Business Wire, San Francisco, Oct. 23, 1991, p. 1.
- Egan, "Ericsson Signs Breakthrough Agreement For Mobile Data Network", Business Wire, San Francisco, May 31, 1989, p. 1.
- Elson et al., "Fine-Grained Network Time Synchronization Using Reference Broadcasts", May 17, 2002, pp. 1-14.

- Eng et al., "A Wireless Broadband Ad-Hoc ATM Local-Area Network", *Wireless Networks* 1, 1995, pp. 161-174.
- Ergen et al., "MEWLANA-Mobile IP Enriched Wireless Local Area Network Architecture", *Proc. Of IEEE Vehicular Technology Conference (Vancouver)*, Mar. 2002, vol. 4, pp. 2449-2453.
- Fenner, *Mobil Address Management And Billing For Personal Communications*, IEEE-ICUPC '92 Proceedings, Sep. 29, 1992-Oct. 2, 1992, pp. 253-257.
- Foyil, "Nokia—Company Report: UBS Phillips & Drew Global Research Group", Oct. 8, 1990, Investext Report No. 1034219, p. 2.
- Frangini, "Rogers Cantel Lauches 'Public Access' Mobile Network", *Computing Canada*, Jun. 7, 1990, vol. 16, No. 12, p. 53.
- Fraser, "The Mobitex Terminal Specification", *Communications*, Jul. 1991, vol. 28, No. 7, pp. 33-38.
- Fraser, "The MTS—Part II", *Communications*, Aug. 1991, vol. 28, No. 8, pp. 52-55.
- Fudge, "Third Generation Mobile Systems—What They Will Do And Who Decide", IEEE-ICUPC '92 Proceedings, Sep. 29, 1992-Oct. 2, 1992, pp. 433-442.
- Gates, "Computers Enter The Wireless Age: New Technology Can Link Terminals Spanning Globe", *Financial Post*, Jun. 8, 1991, p. 13.
- Ghassemian, "Evaluation Of Different Handoff Schemes For Cellular IP", Master's Thesis, Kings College, London, 2001.
- Goldberg, "Systems Engineering And Program Management For Personal Communications In TIP1", IEEE-ICUPC '92 Proceedings, Sep. 29, 1992-Oct. 2, 1992, pp. 151-157.
- Goodman, "Cellular Packet Communications", *IEEE Transactions On Communications*, Aug. 1990, vol. 38, No. 8.
- Haber, "The Art Of Wireless Computing", *Midrange Systems*, Aug. 6, 1991, vol. 4, No. 16, p. 66.
- Hasselberg, "Mobitex Permits Tailored Telecom", *Tele (English Edition)*, No. 2, 1988, vol. XXXXI, pp. 14-16.
- Haug et al., "Microcellular Radio Performance In A Rayleigh/Rician CoChannel Interference Environment", IEEE-ICUPC '92 Proceedings, Sep. 29, 1992-Oct. 2, 1992, pp. 112-115.
- Hayes et al., "Personal Satellite Communications Utilizing The KA-Band", IEEE-ICUPC '92 Proceedings, Sep. 29, 1992-Oct. 2, 1992, pp. 385-390.
- Hightower et al., "Design And Calibration Of The SpotON Ad-Hoc Location Sensing System", Aug. 2001, pp. 1-18.
- Hirschman, "Service Mobility/Transparency For Personal Communications", IEEE-ICUPC '92 Proceedings, Sep. 29, 1992-Oct. 2, 1992, pp. 334-338.
- Ho, "Effects Of Antenna Polarization And Beam Pattern On Multipath Delay Spread And Path Loss In Indoor Obstructed Wireless Channels", IEEE-ICUPC '92 Proceedings, Sep. 29, 1992-Oct. 2, 1992, pp. 92-96.
- Hodes et al., "Composable Ad-Hoc Location-Based Services For Heterogeneous Mobile Clients", *Wireless Networks*, 1989, vol. 5, pp. 411-427.
- Honcharenk et al., "Theoretical Prediction Of UHF Propagation Within Office Buildings", IEEE-ICUPC '92 Proceedings, Sep. 29, 1992-Oct. 2, 1992, pp. 102-105.
- Huang et al., "OPNET Simulation Of A Multi-Hop Self-Organizing Wireless Sensor Network", *Florida Communication Research Labs, Motorola Labs, Fort Lauderdale, FL 33322*, 2002.
- Hunt, "The Regulatory Environment For Personal Communications In The Post-WARC-92 Period", IEEE-ICUPC '92 Proceedings, Sep. 29, 1992-Oct. 2, 1992, pp. 429-432.
- Ioannidis et al., "IP-Based Protocols For Mobile Internetworking", *Proceedings Of Conference On Communications Architecture & Protocols*, 1991, pp. 1-17.
- Jain, "Characteristics Of Destination Address Locality In Computer Networks: A Comparison Of Caching Schemes", Jun. 25, 1990.
- Jakobs et al., "Electronic Mail In Broadcast Networks", IEEE-ICUPC '92 Proceedings, Sep. 29, 1992-Oct. 2, 1992, pp. 412-416.
- Jalali et al., "Performance Of Data Protocols For In-Building Wireless Systems", IEEE-ICUPC '92 Proceedings, Sep. 29, 1992-Oct. 2, 1992, pp. 407-411.
- Jetcheva et al., "Adaptive Demand-Driven Multicast Routing In Multi-Hop Wireless Ad Hoc Networks", *Proceedings Of The 2nd ACM International Symposium On Mobile Ad-Hoc Networking & Computing (Long Beach Session: Routing And Transport)*, 2001, pp. 33-44.
- Johansson et al., "Scenario-Based Performance Analysis Of Routing Protocols For Mobile Ad-Hoc Networks", *Proceedings Of The 5th Annual ACM/IEEE International Conference On Mobile Computing And Networking (Seattle)*, 1999, pp. 195-206.
- Johansson, "The Mobitex Experience", Paper Presented At International Mobile Communications (London 1990), Jun. 1990, pp. 55-68.
- Jung et al., "A Power Saving MAC Protocol For Wireless Networks", Department Of Computer Science, Texas A&M University, Technical Report, Jul. 2002.
- Jung et al., "An Energy Efficient MAC Protocol For Wireless LAN's", Department Of Computer Science, Texas A&M University, Technical Report TR01-017, Jul. 31, 2001.
- Kaplan, "The Network In Your Pocket", *Business Communications Review*, Mar. 1991, vol. 21, No. 3, p. 112.
- Karp et al., "GPSR: Greedy Perimeter Stateless Routing For Wireless Networks", *Proceedings Of The 6th Annual International Conference On Mobile Computing And Networking (Boston)*, 2000, pp. 243-254.
- Karp, "Geographic Routing For Wireless Networks", PhD Thesis, Harvard University, Oct. 2000.
- Katz, "The Use Of Connectionless Network Layer Protocols Over FDDI Networks", *ACM SIGCOMM Computer Communication Review*, vol. 20(3), 1990, pp. 32-45.
- Kay, "Extended-TDMA™ A High Capacity Evolution of U.S. Digital Cellular", IEEE-ICUPC '92 Proceedings, Sep. 29, 1992-Oct. 2, 1992, pp. 182-184.
- Kearns, "Scope Of ZENworks 7 Suite Stretches Far And Wide", *Network World*, (<http://www.networkworld.com/newsletters/netware/2005/0829nw1.html>), Aug. 30, 2005.
- Khandani et al., "ISI-Reduced Modulation Over A Fading Multipath Channel", IEEE-ICUPC '92 Proceedings, Sep. 29, 1992-Oct. 2, 1992, pp. 288-292.
- Kiang, "Characteristics Of Two-Alternative Frequency Channel Assignment Methods For TDMA Wireless Access Systems", IEEE-ICUPC '92 Proceedings, Sep. 29, 1992-Oct. 2, 1992, pp. 355-358.
- Kiang, "Geometrical Ray Tracing Approach For Indoor Wave Propagation In A Corridor", IEEE-ICUPC '92 Proceedings, Sep. 29, 1992-Oct. 2, 1992, pp. 106-111.
- Kikuta, "Global UPT Architecture With International Mobility Management", IEEE-ICUPC '92 Proceedings, Sep. 29, 1992-Oct. 2, 1992, pp. 229-235.
- Kilpatrick, "Mobile Packet-Switched Data Networks", *RF Expo East, Orlando, FL*, Oct. 29, 1991-Oct. 31, 1991, pp. 367-369.
- Kleeman, "Optimal Estimation Of Position And Heading For Mobile Robots Using Ultrasonic Beacons And Dead-Reckoning", *Proceedings Of The 1992 IEEE International Conference On Robotics And Automation (Nice, France)*, 1992.
- Krashinsky et al., "Minimizing Energy For Wireless Web Access With Bounded Slowdown", 2002, *Proc. ACM Mobicon* 02:119-130.
- Krechmer, "A Review Of US Mobile Communications Standards", *Telecommunications*, Jul. 1991, vol. 25, No. 7, p. 43-45.
- Kriz et al., "Spread Spectrum Indoor Video Transmission", IEEE-ICUPC '92 Proceedings, Sep. 29, 1992-Oct. 2, 1992, pp. 421-425.
- Ku, "The Outlook Of DCS 1800 For Personal Communications Networks", IEEE-ICUPC '92 Proceedings, Sep. 29, 1992-Oct. 2, 1992, pp. 168-171.
- Kubo et al., "Simulated Tolerance Of Loop Parameters Of Cartesian Feedback Amplifier For $\pi/4$ -Shifted QPSK Transmitter", IEEE-ICUPC '92 Proceedings, Sep. 29, 1992-Oct. 2, 1992, pp. 136-140.
- Kumar, "Antennas For MSAT Ground Terminals", IEEE-ICUPC '92 Proceedings, Sep. 29, 1992-Oct. 2, 1992, pp. 219-223.
- Kwok, "Wireless Networking Requirements Of Multimedia Applications", IEEE-ICUPC '92 Proceedings, Sep. 29, 1992-Oct. 2, 1992, pp. 402-406.

- Lambert, "Security For Universal Personal Communications", IEEE—ICUPC '92 Proceedings, Sep. 29, 1992-Oct. 2, 1992, pp. 44-48.
- Larsen, "Marketing Mobile Data Services And Equipment", Proceedings Of Cellular & Mobile Communications 88, Nov. 1988, pp. 111-116.
- Larsen, "Mobitex—A System For Mobile Data Communication", Information Network And Data Communication, III, Proceedings Of The IFIP TC6 International Conference On Information Network And Data Communication, Lillehammer, Norway, Mar. 1990, pp. 239-247.
- Larsen, "Mobitex—Public Mobile Radio Service", Communications International, Oct. 1986, vol. 13, Pt. 10, p. 96.
- Lau et al., "Interworking Of Satellite And Terrestrial Networks For Land Mobile Communications", IEEE—ICUPC '92 Proceedings, Sep. 29, 1992-Oct. 2, 1992, pp. 375-379.
- Laval et al., "Cognito Network Overview", Cognito Group Limited, Sep. 19, 1990.
- Laval, "Briefing Document For A Brochure On The Cognito Mobile Messaging Service", Cognito Group Limited, May 22, 1990.
- Lawson-Jenkins, "The Role of GSM In The Development Of Standards For A Worldwide Personal Communication Network", IEEE—ICUPC '92 Proceedings, Sep. 29, 1992-Oct. 2, 1992, pp. 79-81.
- Leibowitz et al., "Rogers Cantel Mobile Communications Inc.—Company Report", Donaldson, Lufkin & Jenrette Securities, Investext Report No. 1145153, Oct. 15, 1991.
- Lin et al., "A Two-Stage Maximum Likelihood Sequence Estimation Technique And Its Application To Data Transmission Protocol In Digital Cellular Radio", IEEE—ICUPC '92 Proceedings, Sep. 29, 1992-Oct. 2, 1992, pp. 303-307.
- Linnartz et al., "Performance Of Personal Communication Networks With Error Correction Coding In Microcellular Channels", IEEE—ICUPC '92 Proceedings, Sep. 29, 1992-Oct. 2, 1992, pp. 308-313.
- Lo et al., "An Estimate Of Network Database Transaction Volume To Support Personal Communications Services", IEEE—ICUPC '92 Proceedings, Sep. 29, 1992-Oct. 2, 1992, pp. 236-241.
- Ioannidis et al., "The Design And Implementation Of A Mobile Internetworking Architecture", 1993 Winter USENIX, San Diego, CA, Jan. 25, 1993-Jan. 29, 1993, pp. 489-500.
- Loberg et al., "The New Swedish Cellular Mobile Radio Service", International Conference On Radio Receivers & Associated Systems (4th: 1986), 1986, Pub. No. 68, pp. 77-82.
- Loberg et al., "Mobitex Brings A New Look To Dispatch Communications", Communications International, Feb. 1985, vol. 12, No. 2, pp. 25-32.
- Long et al., "Rapid Prototyping Of Mobile Context-Aware Applications: The Cyberguide Study", Proceedings Of The 2nd Annual International Conference On Mobile Computing And Networking, (Rye, NY), 1996.
- Loudermilk, "Trio Throws Weight Behind Radio E-Mail Technology", PC Week, Dec. 2, 1991, vol. 8, No. 48, p. 39.
- Lusa, "The ITU's Quadrennial Telecom Show In Geneva Attracts And Dazzles Thousands", Networking Management, Dec. 1991, vol. 9, No. 14, pp. 12-14.
- Lycksell, "Mobitex: A New Radio Communication System For Dispatch Traffic", Tele (English Edition), 1983, vol. 35, Issue 1, pp. 68-75.
- Madhow, "Minimum Mean Squared Error Interference Suppression For Direct-Sequence Spread-Spectrum Code-Division Multiple-Access", IEEE—ICUPC '92 Proceedings, Sep. 29, 1992-Oct. 2, 1992, pp. 273-277.
- Malyan et al., "A Wireless Personal Communications Architecture For Urban Areas", IEEE—ICUPC '92 Proceedings, Sep. 29, 1992-Oct. 2, 1992, pp. 116-120.
- Mandell et al., "A Comparison Of CDMA And Frequency Hopping In A Cellular Environment", IEEE—ICUPC '92 Proceedings, Sep. 29, 1992-Oct. 2, 1992, pp. 172-176.
- Maric et al., "Microcell Planning And Channel Allocation For Manhattan Street Environments", IEEE—ICUPC '92 Proceedings, Sep. 29, 1992-Oct. 2, 1992, pp. 359-363.
- Mathy et al., "An Overlay Tree Building Protocol", J. Crowcroft And M. Hoffman (Eds.) Springer-Verlag Berlin Heidelberg, 2001, pp. 76-87.
- McIlwain et al., "Routing Technology Software Inc. And Ericsson GE Team Up To Provide 'Roadshow' Routing Application To Mobitex Networks Worldwide", Business Wire, San Francisco, Jun. 6, 1991, p. 1.
- "Mobile Radio Interface Layer 3 Specification", Recommendation GSM 04.08, v. 3.3.1, Apr. 1989.
- Mokhtar et al., "Capacity For Cellular CDMA PCS's In Nakagami Fading Log-Normal Shadowing Channels", IEEE—ICUPC '92 Proceedings, Sep. 29, 1992-Oct. 2, 1992, pp. 190-194.
- Morrison et al., "Statistical Analysis And Autoregressive Modeling Of The Indoor Radio Propagation Channel", IEEE—ICUPC '92 Proceedings, Sep. 29, 1992-Oct. 2, 1992, pp. 97-101.
- Mulqueen, "Mobile Data Network Debuts", Data Communications, Jan. 1991, p. 78.
- Murphy et al., "UPT: Mobility vs. Portability", IEEE—ICUPC '92 Proceedings, Sep. 29, 1992-Oct. 2, 1992, pp. 224-228.
- Murthy et al., "A Routing Protocol For Packet Radio Networks", Proceedings Of The 1st Annual International Conference On Mobile Computing And Networking (Berkeley), 1995, pp. 86-95.
- Murthy et al., "An Efficient Routing Protocol For Wireless Networks", Mobile Networks And Applications 1, 1996, pp. 183-197.
- Nakajima et al., "Intelligent Network Architecture For Personal Mobile Telecommunication", IEEE—ICUPC '92 Proceedings, Sep. 29, 1992-Oct. 2, 1992, pp. 339-344.
- Nikaein et al., "DDR-Distributed Dynamic Routing Algorithm For Mobile Ad Hoc Networks", Proc. Of The 1st Annual ACM International Symposium On Mobile Ad Hoc Networking & Computing (Boston), Session A, 2000, pp. 19-27.
- Noel et al., "The Development Of An 8 KBPS GMSK-Like Modem For Mobitex", IEEE Pacific Rim Conference On Communications, Computers And Signal Processing, May 9, 1991-May 10, 1991, vol. 2, pp. 791-794.
- Noerpel, "Hybrid Signaling For The Air Interface For A Wireless Access Communication System", IEEE—ICUPC '92 Proceedings, Sep. 29, 1992-Oct. 2, 1992, pp. 49-53.
- O'Byrne, "Digital Cellular Over The Cable Television Fiber-Optic Plant", IEEE—ICUPC '92 Proceedings, Sep. 29, 1992-Oct. 2, 1992, pp. 205-208.
- Pande et al., "Application Of Wireless Access To Telecommunication Services In Developing Countries", IEEE—ICUPC '92 Proceedings, Sep. 29, 1992-Oct. 2, 1992, pp. 82-86.
- Perlman, "An Algorithm For Distributed Computation Of A Spanning Tree In An Extended LAN", Proceedings Of The Ninth Symposium On Data Communication (Whistler Mountain, British Columbia, Canada), 1985, pp. 44-53.
- Perlman, "Incorporation Of Multiaccess Links Into A Routing Protocol", Proceedings Of The Eighth Symposium On Data Communications (North Falmouth, MA), 1983, pp. 85-94.
- Pouwelse et al., "Power Consumption Trade-Offs For Wireless Audio Access", Delft University Of Technology, 2000.
- Powell, "Cellular Telephones Give Way To 'Mobile Communications'", Communications Canada, Jun. 22, 1989, p. 35.
- Powell, "Use Cellular To Support Datacom Applications", Networking Management, Apr. 1991, vol. 9, No. 5, pp. 30-34.
- Prakash, "A Routing Algorithm For Wireless Ad Hoc Networks With Unidirectional Links", Wireless Networks, 2000, vol. 7, pp. 617-625.
- Prakash, "Unidirectional Links Prove Costly In Wireless Ad Hoc Networks", Proceedings Of The 3rd International Workshop On Discrete Algorithms And Methods For Mobile Computing And Communication (Seattle), 1999, pp. 15-22.
- Priyantha et al., "The Cricket Compass For Context-Aware Mobile Applications", Proceedings Of The 7th Annual International Conference On Mobile Computing And Networking (MOBICOM 2000), 2001, PP. 1-14.
- Purton, "BT Admits Impact Of Recession But Still Manages To Improve Results", Europe 2000—Communications & Information Technology, vol. 3, No. 7, pR 93(1), Sep. 1991.
- Ramésh et al., "Spectral Shaping Using Coded Modulation For Mobile Radio", IEEE—ICUPC '92 Proceedings, Sep. 29, 1992-Oct. 2, 1992, pp. 298-302.

- Reinbold et al., "A Comparison Of IP Mobility Protocols", Tech. Rep. Infonet-TR-13, Dec. 2001.
- Reiter, "Three Cellular Modems", PC Magazine, Dec. 25, 1990, vol. 9, No. 22, p. 365.
- Rodrigues et al., "Rural Satellite Service: A Mexican View", IEEE—ICUPC '92 Proceedings, Sep. 29, 1992-Oct. 2, 1992, pp. 380-384.
- Rohani et al., "Low Cost High Performance CDMA System For U.S. PCS", IEEE—ICUPC '92 Proceedings, Sep. 29, 1992-Oct. 2, 1992, pp. 278-282.
- Röhl et al., "A Short Look On Power Saving Mechanism In The Wireless LAN Standard" Draft IEEE 802.11, 1997, pp. 1-6.
- Royer et al., "Multicast Operation Of The Ad-Hoc On-Demand Distance Vector Routing Protocol", Proceedings Of The 5th Annual ACM/IEEE International Conference On Mobile Computing And Networking (Seattle), 1999, pp. 207-218.
- Salkintzis et al., "Mobile Packet Data Technology: An Insight Into MOBITECH Architecture," IEEE Personal Communications, Feb. 1997, pp. 10-18.
- Sanford et al., "Facade Integrated Microstrip Patch Antennas Applied To Personal communication Networks", IEEE—ICUPC '92 Proceedings, Sep. 29, 1992-Oct. 2, 1992, pp. 214-218.
- Savage, "A Technology To Link Professionals On The Road To Central Information Systems: Mobitex Public Networks In Europe", World Congress On Applications Of Transport Telematics And Intelligent Vehicle-Highway Systems, 1995, vol. 5, pp. 2662-2668.
- Schwartz, "Ericsson Set To Debut Radio Modems", Communications Week, Dec. 2, 1991, p. 21.
- Seshan et al., "The Role Of Digital Signal Processing In Personal Communications Networks", IEEE—ICUPC '92 Proceedings, Sep. 29, 1992-Oct. 2, 1992, pp. 200-204.
- Seshan, "Low-Latency Handoff For Cellular Data Networks", Ph.D. Thesis, University Of California At Berkeley, 1995.
- Sheety et al., "Development In Mobile Markets", Communications International, Dec. 1991, vol. 18, No. 12, p. 47.
- Sneed, "A 2-GHz CMOS LC-Tuned VCO Using Switched-Capacitors To Compensate For Bond Wire Inductance Variation", University Of California, Berkeley, Dec. 21, 2000, pp. 1-51.
- Sollenberger et al., "An Efficient TDMA Radio Link And Architecture For Wireless Local Access", IEEE—ICUPC '92 Proceedings, Sep. 29, 1992-Oct. 2, 1992, pp. 262-266.
- Srisathapornpat et al., "Coordinated Power Conservation For Ad Hoc Networks", IEEE International Conference On Communications, 25(1), 2002, pp. 3330-3335.
- Stein, "Greater Efficiency With Mobile Data Communication", Ericsson Review, 1991, vol. 68, Issue 4, pp. 104-110.
- Steinert-Threlkeld, "Ericsson Unit To Aid New Network; Richardson Firm To Provide Equipment For Cellular Data Link", The Dallas Morning News, Record No. DAL1073150, Jun. 1, 1989.
- "Subscriber Identity Modules, Functional Characteristics", Recommendation GSM 02.17, v. 3.2.0, Mar. 1990.
- Sudame et al., "On Providing Support For Protocol Adaptation In Mobile Wireless Networks", Mobile Networks And Applications 6, 2001, pp. 43-55.
- Sweeny, "IBM, Motorola Join To Offer Mobile Data", Communications Week, Feb. 5, 1990, vol. 286, pp. 2, 84.
- Takats et al., "A Network Management Architecture For Satellite Based Personal Communications", IEEE—ICUPC '92 Proceedings, Sep. 29, 1992-Oct. 2, 1992, pp. 395-401.
- Tan et al., "A Fast Handoff Scheme For Wireless Networks", Proceedings Of The 2nd ACM International Workshop On Wireless Mobile Multimedia (Seattle, WA), 1999.
- Tan et al., "Mobicast: A Multicast Scheme For Wireless Networks", Mobile Networks And Applications 5, 2000, pp. 259-271.
- Tanno et al., "Multiplexing Of Communication Ports On Unix Terminals For Packet Radio Networks", IEEE—ICUPC '92 Proceedings, Sep. 29, 1992-Oct. 2, 1992, pp. 417-420.
- Technical Manual Callmaster/Smart MT-270, 1982.
- Todd et al., "Low Power Rendezvous In Embedded Wireless Networks", Proceedings Of The 1st ACM International Symposium On Mobile Ad Hoc Networking & Computing (Boston), Sessions D, 2000, pp. 107-118.
- Todd et al., "Space And Frequency Diversity Measurements Of The 1.7 GHz Indoor Radio Channel For Wireless Personal Communications", IEEE—ICUPC '92 Proceedings, Sep. 29, 1992-Oct. 2, 1992, pp. 87-91.
- Toh, "A Hybrid Handover Protocol For Local Area Wireless ATM Networks", Mobile Networks And Applications 1, 1996, pp. 313-334.
- Troe, "Mobile-Data Packet-Networks", Electro International Conference Record, New York, Apr. 16, 1992-Apr. 18, 1991, pp. 510-513.
- Tsukamoto et al., "Mobility Management Of Transport Protocol Supporting Multiple Connections", Proceedings Of The Second International Workshop On Monthly Management & Wireless Access Protocols (Philadelphia, PA), Sessions 4, 2004, pp. 83-87.
- Ubiquity 1000 Cellular Communications System—Technical Information, May 18, 1994.
- Ubiquity 1000 Cellular Communications System For Your IBM ThinkPad™ 750, User's Guide, 1994.
- Valko et al., "On The Analysis Of Cellular IP Access Networks", Sixth JFIP International Workshop On Protocols For High Speed Networks (Salem), Aug. 25, 1999-Aug. 27, 1999.
- Velocci, "Orbcomm Nears Full Operational Status", Aviation Week & Space Technology, Nov. 23, 1998, vol. 149, No. 21, pp. 46-78.
- Vijayan et al., "The Dynamic Behavior Of Handoff Algorithms", IEEE—ICUPC '92 Proceedings, Sep. 29, 1992-Oct. 2, 1992, pp. 39-43.
- Vinton, "Cellular Market Booms, But Competition Looms", Business Communications Review, Aug. 1990, vol. 20, No. 8, p. 73-77.
- Vizard, "Standards For UPT Introduction and Evolution", IEEE—ICUPC '92 Proceedings, Sep. 29, 1992-Oct. 2, 1992, pp. 74-78.
- Wang et al., "On Frequency-Hop Multiple Access Sequence", IEEE—ICUPC '92 Proceedings, Sep. 29, 1992-Oct. 2, 1992, pp. 177-181.
- Wang et al., "Tracking A Head-Mounted Display In A Room-Sized Environment With Head-Mounted Cameras", Proc. Of Helmet-Mounted Displays II, Orlando, FL, Apr. 19, 1990-Apr. 20, 1990, vol. 1290 SPIE.
- Wang, "The Hierarchical Structure Of Tracing Strategy For Universal Personal Communication Systems", IEEE—ICUPC '92 Proceedings, Sep. 29, 1992-Oct. 2, 1992, pp. 242-246.
- Want et al., "The Active Badge Location System", ACM Transactions On Information Systems, Jan. 1992, vol. 10, No. 1, pp. 91-102.
- Webb, "Voice And Data Privacy Using Chaotic Time Sequences", IEEE—ICUPC '92 Proceedings, Sep. 29, 1992-Oct. 2, 1992, pp. 33-38.
- Wilber-Ham et al., "Universal Personal Telecommunication (UPT) Service And Architecture Overview", IEEE—ICUPC '92 Proceedings, Sep. 29, 1992-Oct. 2, 1992, pp. 64-68.
- Williams, "It's Telecom All The Way For A Rejuvenated Ericsson (LM Ericsson of Sweden Sticks To Telecommunications Business)", Electronic Business Buyer, Jul. 10, 1989.
- Wilson et al., "CDMA Versus Dynamic TDMA For Access Controls In An Integrated Voice/Data PCN", IEEE—ICUPC '92 Proceedings, Sep. 29, 1992-Oct. 2, 1992, pp. 267-272.
- Winters et al., "The Capacity Of Wireless Communication Systems Can Be Substantially Increased By The Use Of Antenna Diversity", IEEE—ICUPC '92 Proceedings, Sep. 29, 1992-Oct. 2, 1992, pp. 28-32.
- Wolter, "Multiplexing On The Downlink Of A TDMA-Based Radio System", IEEE—ICUPC '92 Proceedings, Sep. 29, 1992-Oct. 2, 1992, pp. 258-261.
- Wolterink, "Handoff, A Necessary Feature In Wireless Office Systems", IEEE—ICUPC '92 Proceedings, Sep. 29, 1992-Oct. 2, 1992, pp. 369-374.
- Wu et al., "AMRIS: A Multicast Protocol For Ad Hoc Wireless Networks", Proceedings of IEEE MILCOMM '99 (Atlantic City, NJ), 1999, pp. 1-5.
- Yamagishi et al., "A Low-Voltage 6-GHz-Band CMOS Monolithic LC-Tank VCO Using A Tuning-Range Switching Technique", IEEE MTT-S Digest, 2000, pp. 735-738.
- Yu, "IS-41 For Mobility Management", IEEE—ICUPC '92 Proceedings, Sep. 29, 1992-Oct. 2, 1992, pp. 158-162.

- Cellular Digital Packet Data System Specification Release 10—Book 1, N/A, Jul. 19, 1993.
- Cellular System Dual-Mode Station—Base Station Compatibility Standard, EIA/TIA/IS-54, May 1, 1990.
- ESTI Radio Equipment And Systems (RES); Digital Equipment Cordless Telecommunications (DECT) Common Interface Part 1: Overview, ETS 300 175-1, Oct. 1, 1992.
- ESTI Radio Equipment And Systems (RES); Digital Equipment Cordless Telecommunications (DECT) Common Interface Part 2: Physical Layer, ETS 300 175-2, Oct. 1, 1992.
- ESTI Radio Equipment And Systems (RES); Digital Equipment Cordless Telecommunications (DECT) Common Interface Part 4: Data Link Control Layer, ETS 300 175-4, Oct. 1, 1992.
- ESTI Radio Equipment And Systems (RES); Digital Equipment Cordless Telecommunications (DECT) Common Interface Part 6: Identities And Addressing, ETS 300 175-6, Oct. 1, 1992.
- ESTI Radio Equipment And Systems (RES); Digital Equipment Cordless Telecommunications (DECT) Common Interface Part 7: Security Features, ETS 300 175-7, Oct. 1, 1992.
- ESTI Radio Equipment And Systems (RES); Digital Equipment Cordless Telecommunications (DECT) Common Interface Part 8: Speech Coding And Transmission, ETS 300 175-8, Oct. 1, 1992.
- ESTI Radio Equipment And Systems (RES); Digital Equipment Cordless Telecommunications (DECT) Common Interface Part 9: Public Access Profile, ETS 300 175-9, Oct. 1, 1992.
- ETSI Handbook Guide To The Application Of The PNE Rule To The Drafting And Presentation Of ETSI Standards v 1.3, May 1990.
- Fast And Scalable Handoffs For Wireless Internet Works, Proceedings Of The 2nd Annual International Conference On Mobile Computing And Networking (Rye, NY), 1995, pp. 56-66.
- File History of U.S. Appl. No. 08/027,140, Bates Nos. BCMITC000089531-664, Mar. 1993.
- File History of U.S. Appl. No. 08/101,254, Bates Nos. BCMITC0000793836-978, Aug. 1993.
- File History of U.S. Appl. No. 08/114,872, Bates Nos. QBB220620-1242, Aug. 1993.
- File History of U.S. Appl. No. 08/431,077, Bates Nos. BCMITC000079534-862, Apr. 1995.
- File History of U.S. Appl. No. 08/487,609, Bates Nos. BCMITC0000792166-658, Jun. 1995.
- File History of U.S. Appl. No. 08/513,648 ('983 file history), Bates Nos. BCMITC000071666-72400, Aug. 1995.
- File History of U.S. Appl. No. 09/060,287 ('311 file history), Bates Nos. BCMITC000071327-71665, Apr. 1998.
- Lee, Mobile Cellular Telecommunications Systems, 1989, Bates Nos. QBB147008-463.
- L. Kleinrock and F.A. Tobagi, "Packet Switching in Radio Channels; Part IV—Stability Considerations and Dynamic Control In Carrier Sense Multiple Access," IEEE Transactions on Communications, vol. COM-25, No. 10, Oct. 1977.
- M. B. Pursley, "The Role of Spread Spectrum in Packet Radio Networks," Proceedings of the IEEE, vol. 75, No. 1, Jan. 1987.
- J. O. Onunga and R. W. Donaldson, "Performance Analysis of CSMA with Priority Acknowledgements (CSMA/PA) on Noisy Data Networks with Finite User Population," IEEE Transactions on Communications, vol. 39, No. 7, Jul. 1991.
- L. Kleinrock and J. Silvester, "Spatial Rouse in Multihop Packet Radio Networks," Proceedings of the IEEE, vol. 75, No. 1, Jan. 1987.
- International Standard ISO/DIS 8802-2.2, Jun. 1, 1992.
- A. S. Tanenbaum, "Computer Networks," Prentice Hall, Second Edition, Dec. 1998.
- D.E. Comer, "Internetworking with TCP/IP", Prentice Hall, Dec. 1991.
- Biba, *A Hybrid Wireless MAC Protocol Supporting Asynchronous and Synchronous MSDU Delivery Services*, IEEE P802.11/91-92.
- Cheah, *A Proposed Architecture and Access Protocol Outline for the IEEE 802.11 Radio LAN Standards, Part II*, Document IEEE P802.11/91-54.
- Cox, *A Radio System Proposal for Widespread Low-Power Tetherless Communications*, IEEE Transactions on Communications, vol. 39, No. 2 (Feb. 1991).
- Natarajan et al., *Battery Efficient Operation of Radio MAC Protocol*, Document IEEE P802.11/91-102.
- Rypinski, *Power-Drain Considerations for Full Time and Sleep Mode Radio Receivers*, Document IEEE P802.11/91-99.
- Robert Meier's Masters Thesis, *Mobile Computer Network Architecture* (May 1993).
- Digital European Cordless Telecommunications Reference Document* (Mar. 1991).
- Haine, *A New Radio Access Protocol and Network Architecture for Mobile Packet Data* 41st IEEE Vehicular Technology Conference, Jul. 1991.
- Owen, *The DECT Radio Interface*, Colloquium on CT2/CA1 And DECT Cordless Telecommunications (1990).
- Tuttlebee, *Cordless Telecommunications in Europe* (1990).
- Radio Equipment And Systems (RES); Digital ESTI Radio Equipment And Systems (RES); Digital Equipment Telecommunications (DECT) Common Interface Part 5: Network Layer, ETS 300 175-5, Oct. 1, 1992.
- Recommended Minimum Performance Standards For 800 MHz Dual mode Mobile Stations, EIA/TIA/IS-55, Dec. 1, 1991, Bates Nos. QBB149924-150025.
- Service Accessibility—Change Request, GSM 02.11 v 4.0, Feb. 6, 1992.
- Service Accessibility—GSM 02.11 v 4.3.0, Oct. 1992.
- Service Accessibility—GSM 02.11 v 4.5.0, Apr. 1993, Bates Nos. QBB153507-515.
- Balston, Cellular Radio Systems, 1993.
- Lo et al., "An Estimate of Network Database Transaction Volume to Support Personal Communications Services," IEEE - ICUPC. '92 Proceedings, pp. 236-241, Sep. 29, 1992-Oct. 2, 1992.
- Lo, "A 1.5-V 900-MHz Monolithic CMOS Fast-Switching Frequency Synthesizer for Wireless Applications," Symposium on VLSI Circuits of Technical Papers, pp. 238-241, 2000.
- Alvarez, A Wide-Bandwidth Low-Voltage PLL for PowerPC Microprocessors, Symposium on VLSI Circuits Digest of Technical Papers, 1994.
- "The Second Overseas Radio Wave Utilization System Investigation Committee Report", Kaigai Denpa Riyo Shisutemu Chosadan Hokokusho, Dai2kai, Showa, 1987, Abstract.
- Jane Generic Design Specification, Bates No. E 00 0745C-0778C.
- Katarina Standard Cell Specification, Bates No. E 00 0087C-0242C.
- Katie Gate Array Specification, Bates No. E 00 1498C-1620C.
- Mobitex Operators Association, "Mobitex Terminal Specification to be Used With Cante Mobitex Radio Network Issue RIA 8000 bps," Feb. 26, 1990.
- Radio Data Link Access Procedure published by Motorola, Mar. 1991.
- Notice Regarding Issuance of Initial Determination and Recommended Determination on Remedy and Bond, Oct. 10, 2006.
- Rebuttal Exper Report of Ray Nettleton Regarding Validity of U.S. Patent Nos. 5,714,983 and 6,374,311 (redacted version), Dec. 15, 2005.
- Invalidity Expert Report of Dr. John Proakis (redacted version), Dec. 5, 2005.
- Mobitex System Description MTS02.1.
- Mobitex Network Layer for Terminals Appendix B MTS09A.2.
- GMS 07.01 v 3.13.0, Feb. 1991.
- Qualcomm Incorporated's Sixth Supplemental Objections and Responses to Complainant's First Set of Interrogatories (Nos. 1-15), Dec. 9, 2005.
- Yu, "Overview of EIA/TIA IS-41", IEEE 1992.
- Qualcomm Incorporated's Sixth Supplemental Objections and Responses to Complainant's First Set of Interrogatories (Nos. 1-15), Dec. 9, 2005.
- Kishine et al., "A 2.5 Gb/s Clock and Data Recovery IC With Tunable Jitter Characteristics for use in LAN's and WAN's", IEEE J. of Solid-State Circuits, Jun. 1999, vol. 34, No. 6, pp. 805-12.
- Kral et al., "RF-CMOS Oscillators With Switched Tuning", Custom IC Conference, Santa Clara, CA, May 1998, pp. 555-558.
- Kral, "a. 2.4 GHz CMOS Frequency Synthesizer", UCLA Integrated Circuits and Systems Laboratory, May 1998.
- Second Supplemental Expert Report of Dr. John Proakis (redacted version), Feb. 9, 2006.
- Expert Report of Duane Rabe, Mar. 14, 2008.
- Initial Expert Report of Tim A. Williams, Ph.D., Mar. 14, 2008.

Fisher, "Dual mode mobile unit for next generation digital narrow channel cellular telephone system," 38th IEEE Vehicular Tech. Conf., pp. 543-547, 1988.

Decision of Appeals 2007-1493, -1494, -1495, -1496, -1497, -1498, -1499, -1514, -1573, 2008-1004, -1009, -1010, -1012, -1013, -1015, -1018, -1019 in the United States Court of Appeals for the Federal Circuit, *Kyocera Wireless Corporation, et al. v. International Trade Commission and Broadcom Corporation*, on appeal from the United States International Trade Commission in Investigation No. 337-TA-543, Decided Oct. 14, 2008.

EIA/TIA Interim Standards, "Cellular System Dual-Mode Station - Base Station Compatibility Standard," Revision A, Mar. 1991, EIA/TIA/IS-54-A.

EIA/TIA Interim Standards, "Cellular System Dual-Mode Station - Base Station Compatibility Standard," Revision B, Apr. 1992, EIA/TIA/IS-54-B.

Intel 8088 data sheet, Aug. 1990.

M68HJC11 Reference Manual, Rev. 3.0, 1991.

Zilog Z80 Product Specification, Jan. 1978.

Decision of Appeal 2007-1164 in the United States Court of Appeals for the Federal Circuit, *Broadcom Corporation v. International Trade Commission and Qualcomm Incorporated*, on appeal from the United States International Trade Commission in Investigation No. 337-TA-543, Decided Sep. 19, 2008.

Mobitex Operators Association, "Mobitex Terminal Specification to be Used With Cantele Mobitex Radio Network Issue R1A 8000 bps," Feb. 26, 1990.

Mobitex Operators Association, "Addendum Battery-Saving Protocol for Portable Terminals," Aug. 17, 1990.

Radio Data Link Access Procedure published by Motorola, Mar. 1991.

Notice Regarding Issuance of Initial Determination and Recommended Determination on Remedy and Bond, Oct. 10, 2006.

Rebuttal Expert Report of Ray Nettleton Regarding Validity of U.S. Patent Nos. 5,714,983 and 6,374,311 (redacted version), Dec. 15, 2005.

Invalidity Expert Report of Dr. John Proakis (redacted version), Dec. 5, 2005.

Mobitex Network Layer for Terminals Appendix B MTS09A.2.

GSM 07.01 v 3.13.0, Feb. 1991.

Qualcomm Incorporated's Sixth Supplemental Objections and Responses to Complainant's First Set of Interrogatories (Nos. 1-15), Dec. 9, 2005.

Qualcomm Incorporated's Sixth Supplemental Objections and Responses to Complainant's First Set of Interrogatories (Nos. 1-15), Dec. 9, 2005.

Kishine et al., "A 2.5 Gb/s Clock and Data Recovery IC With Tunable Jitter Characteristics for use in LAN's and WAN's", IEEE J. of Solid-State Circuits, Jun. 1999, vol. 34, No. 6, pp. 805-812.

Kral et al., "RF-CMOS Oscillators With Switched Tuning", Custom IC Conference, Santa Clara, CA, May 1998, pp. 555-558.

Kral, "A 2.4 GHz CMOS Frequency Synthesizer", UCLA Integrated Circuits and Systems Laboratory, Mar. 1998.

Second Supplemental Expert Report of Dr. John Proakis (redacted version), Feb. 9, 2006.

Rubbermark, Generic Design Specification Jane Pocket Telephones, Dec. 22, 1992, Bates No. E 00 0745C-0778C.

Katarine Standard Cell Specification, Aug. 12, 1992, Bates No. E 00 0087C-0242C.

Katie Gate Array Specification, Jan. 24, 1992, Bates No. E 00 1498C-1620C.

Mobitex System Description MTS02.1, Feb. 19, 1990.

Yu, "Overview of EIA/TIA IS-41," IEEE 1992, pp. 220-224, Oct. 19-21, 1992.

* cited by examiner

Primary Examiner—Philip J Sobutka

(74) Attorney, Agent, or Firm—McAndrews, Held & Mallow, Ltd.

(57)

ABSTRACT

Improved apparatus for a radio communication system having a multiplicity of mobile transceiver units selectively in communication with a plurality of base transceiver units which, in turn, communicate with one or more host computers for storage and manipulation of data collected by bar code scanners or other collection means associated with the mobile transceiver units. A network controller and an adapter which has a simulcast and sequential mode provide selective interface between host computers and base transceivers. A scheme for routing data through the communication system is also disclosed wherein the intermediate base stations are organized into an optimal spanning-tree network to control the routing of data to and from the RF terminals and the host computer efficiently and dynamically. Additionally, redundant network and communication protocol is disclosed wherein the network utilizes a polling communication protocol which, under heavy loaded conditions, requires that a roaming terminal wishing to initiate communication must first determine that the channel is truly clear by listening for an entire interpoll gap time. In a further embodiment, a criterion used by the roaming terminals for attaching to a given base station reduces conflicts in the overlapping RF regions of adjacent base stations.

203 Claims, 26 Drawing Sheets

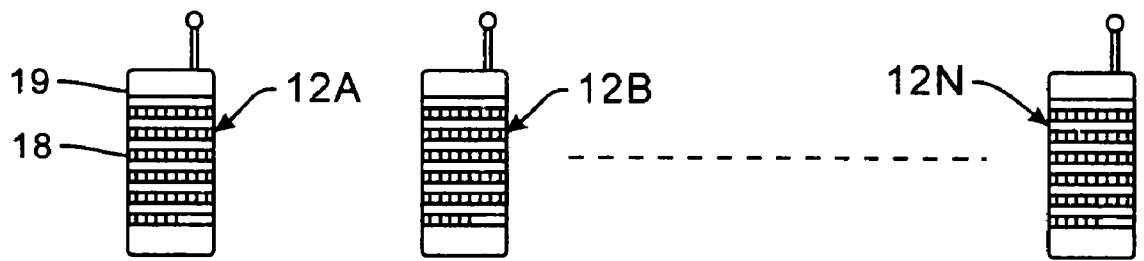

Portable Radio
Terminals

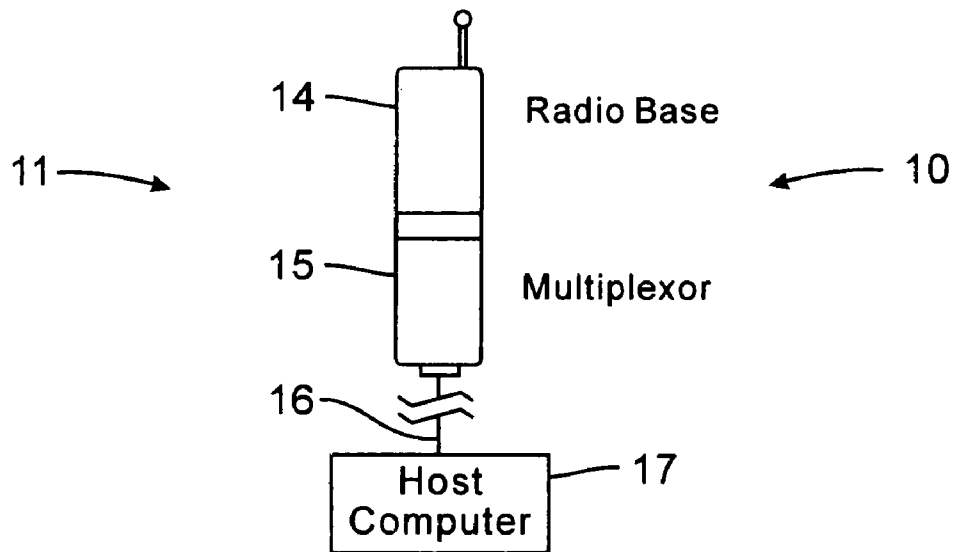

Fig. 1
(Prior Art)

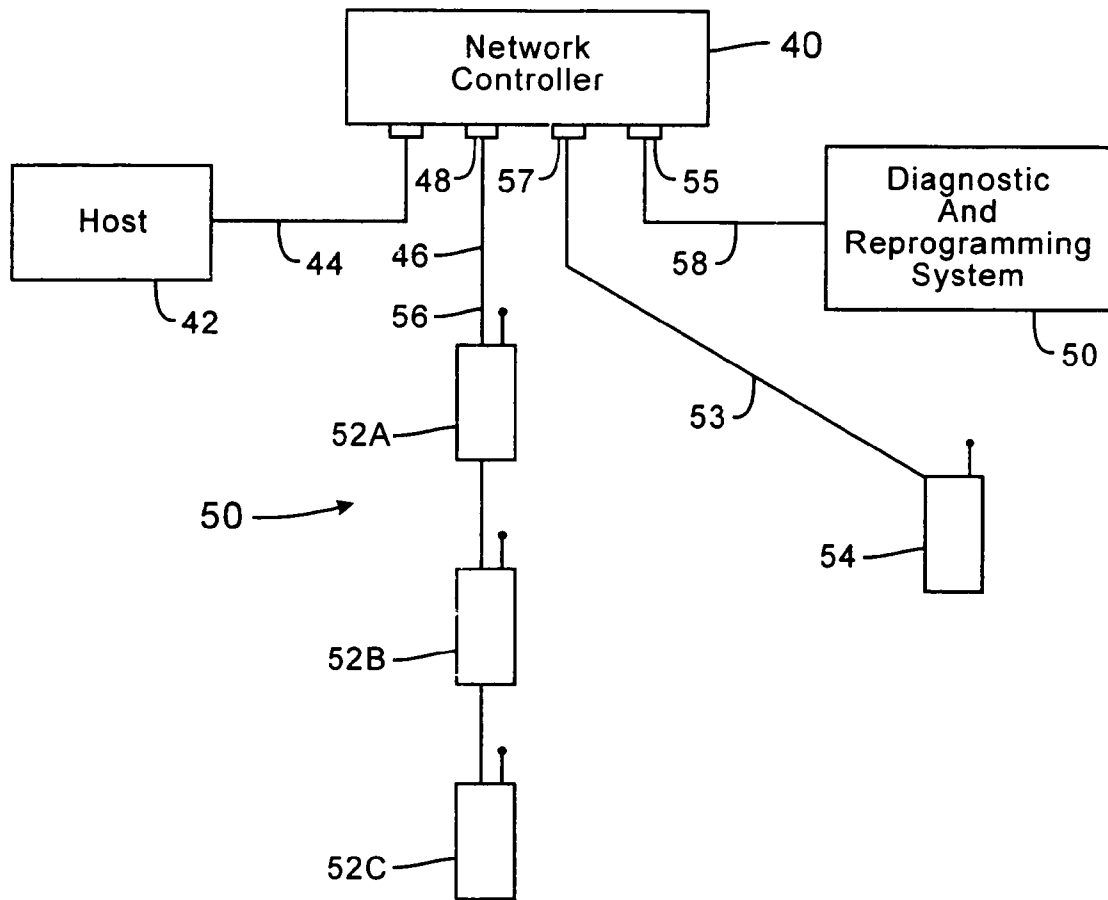

Fig. 3

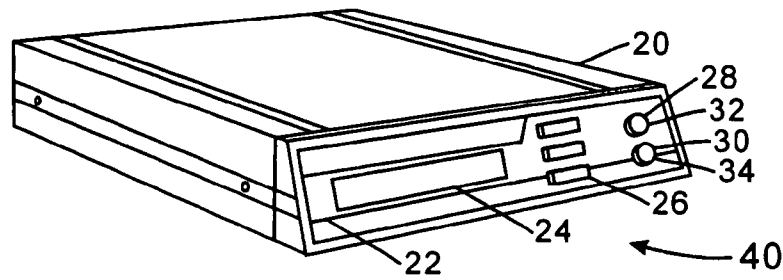

Fig. 2

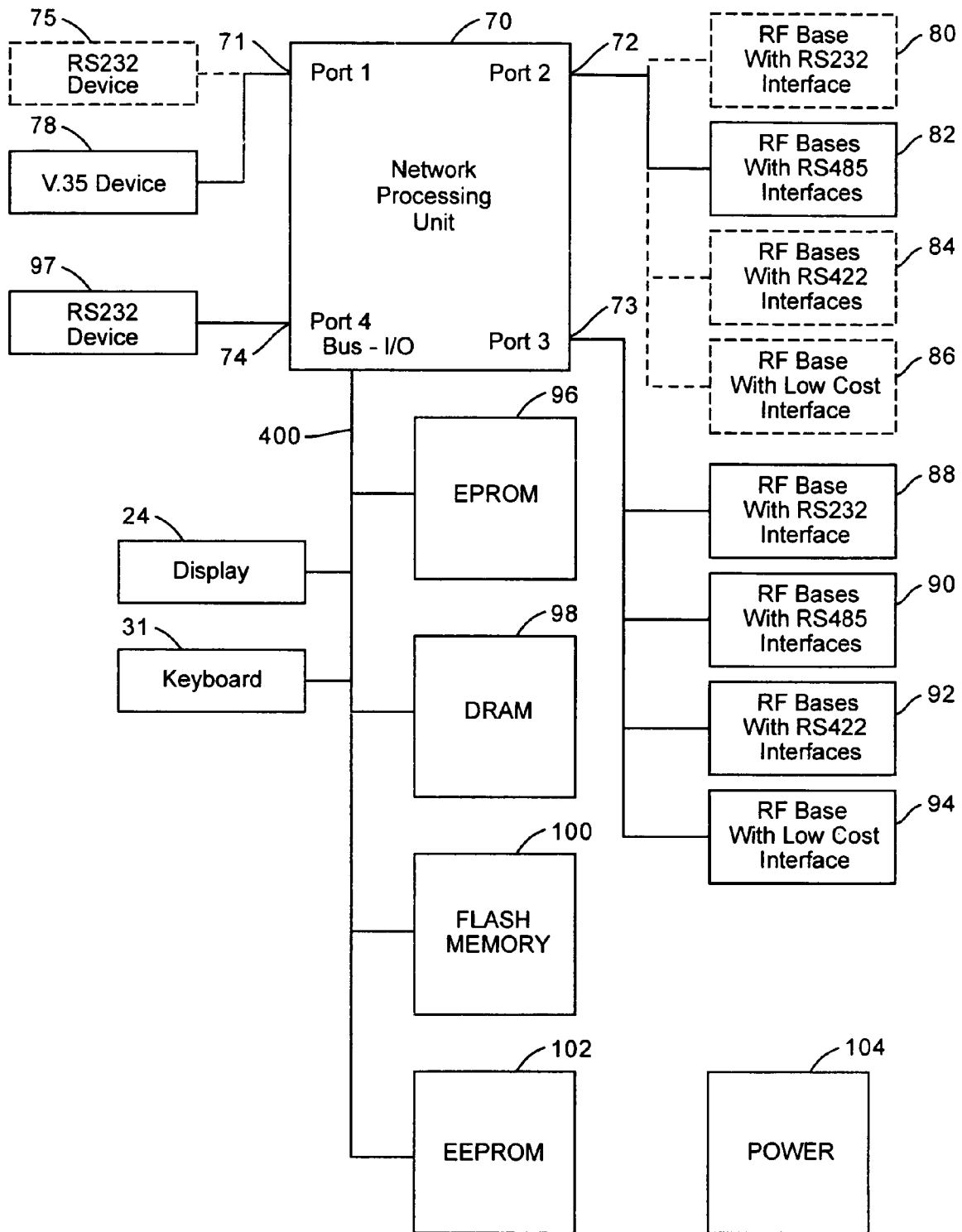

Fig. 4

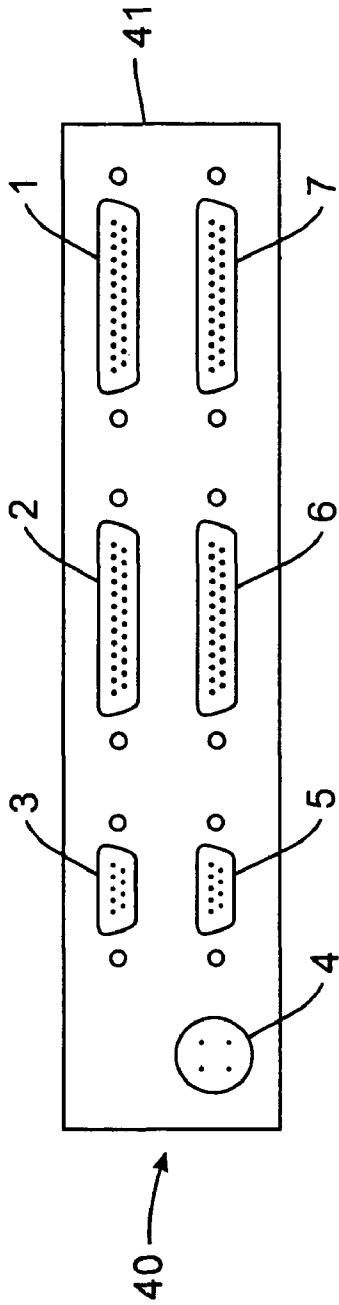

Fig. 5

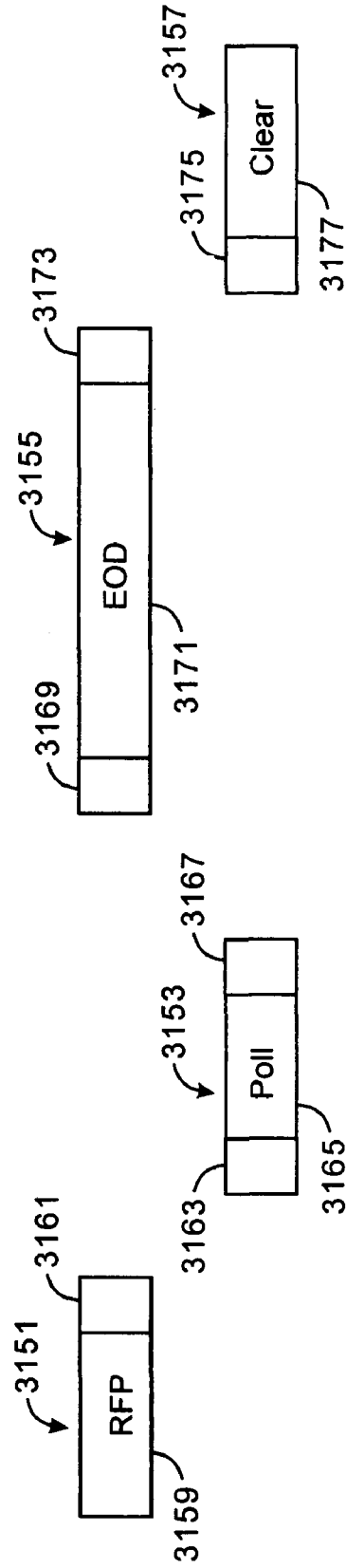

Fig. 20

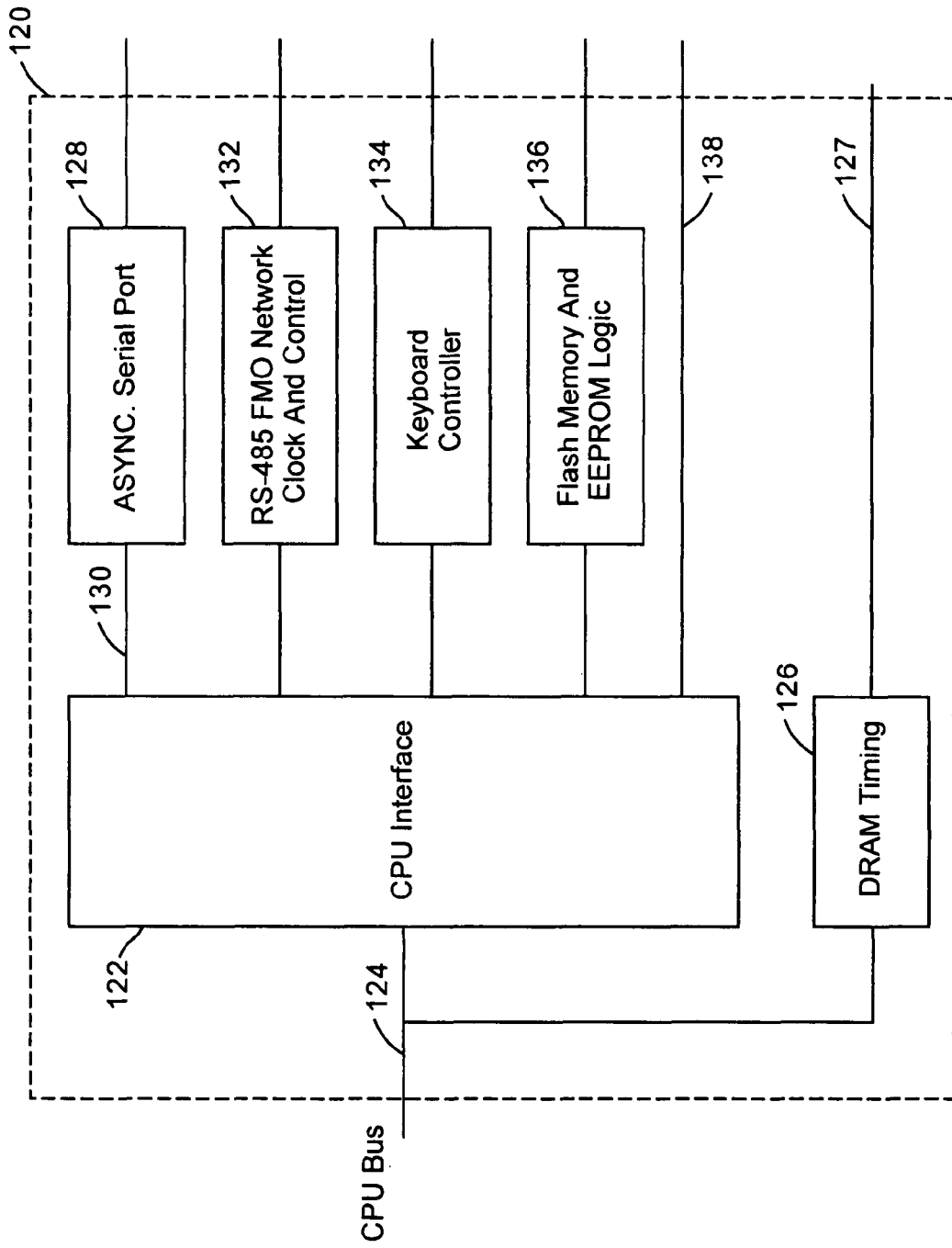

Fig.6

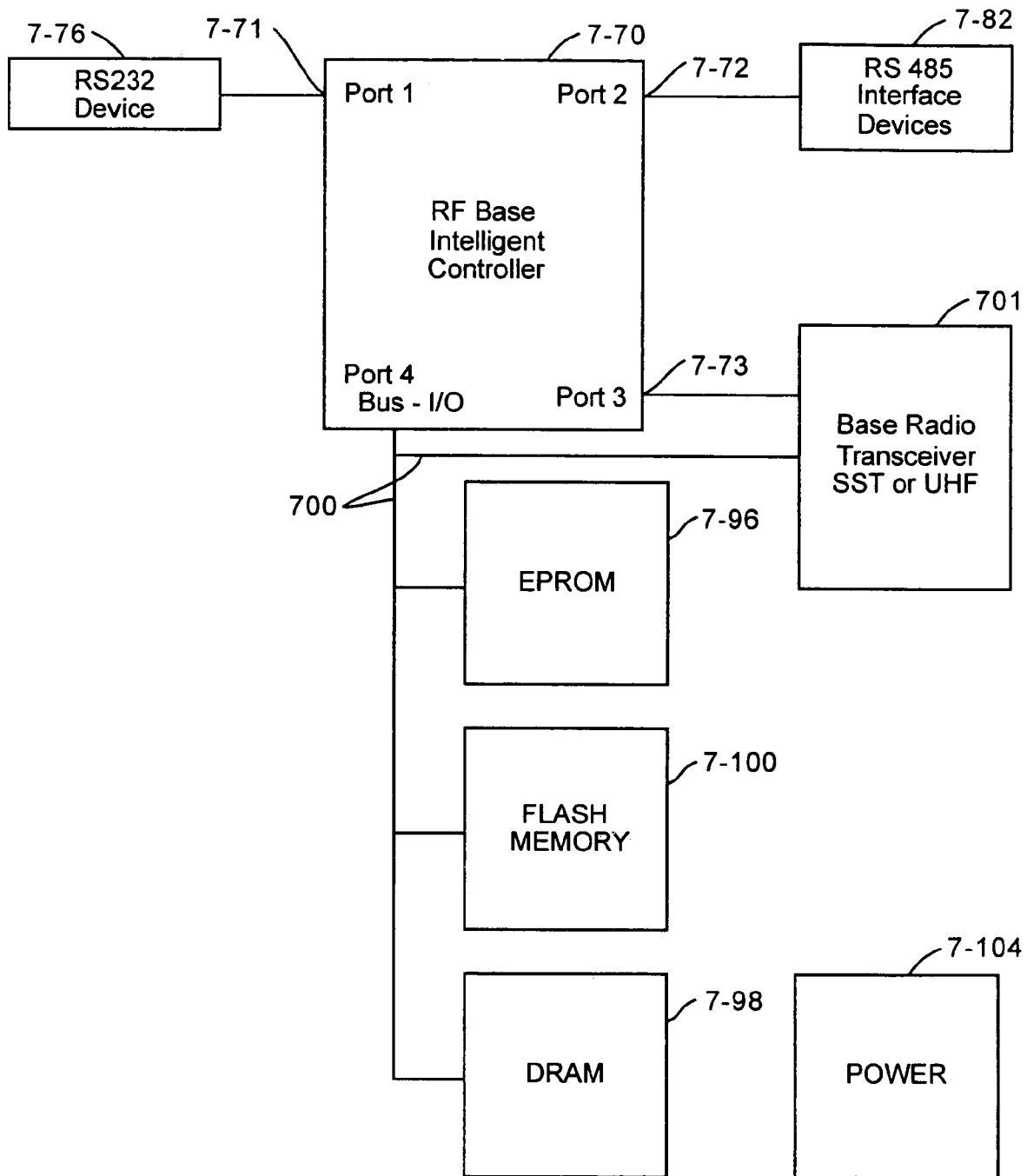

Fig. 7

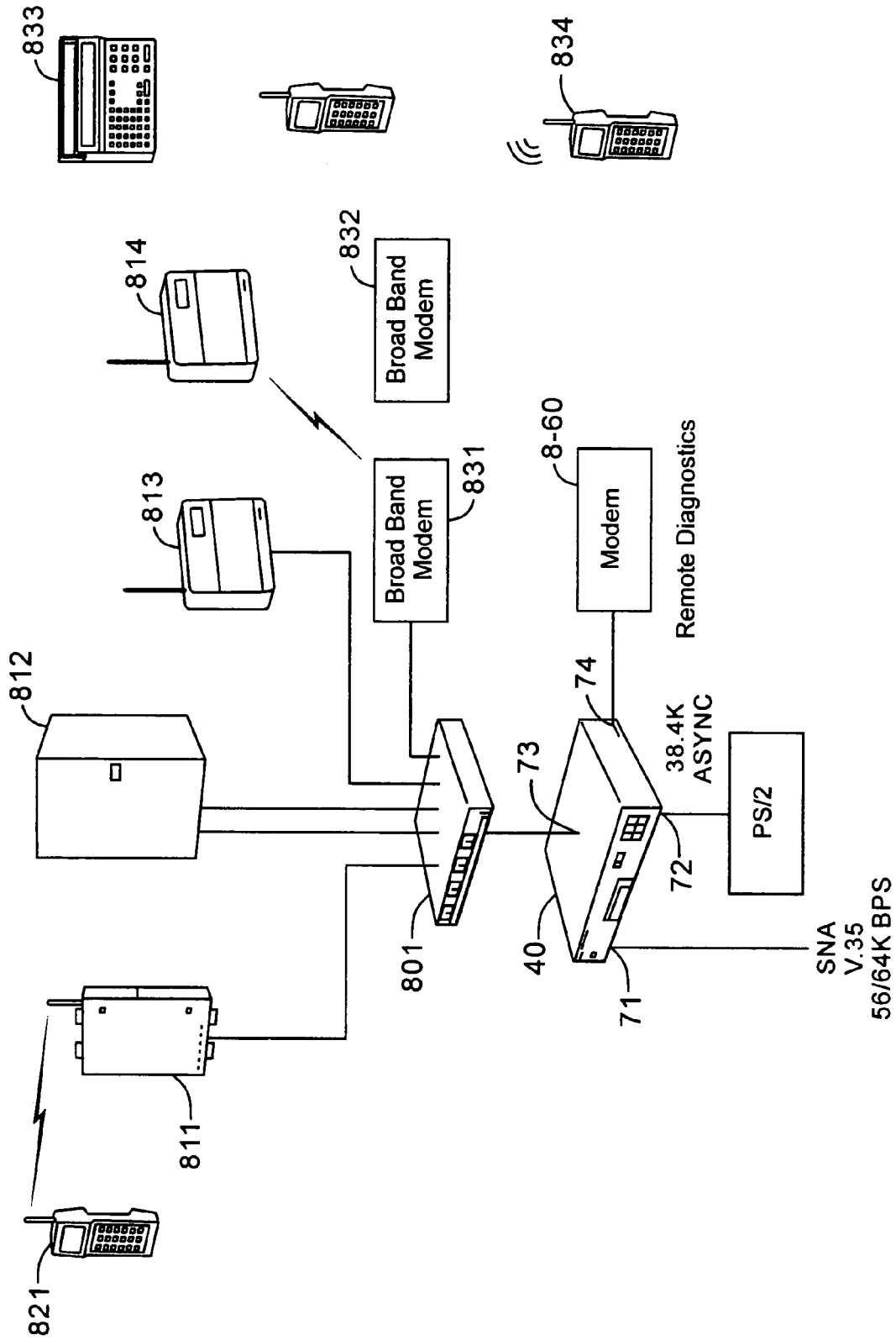

Fig. 8

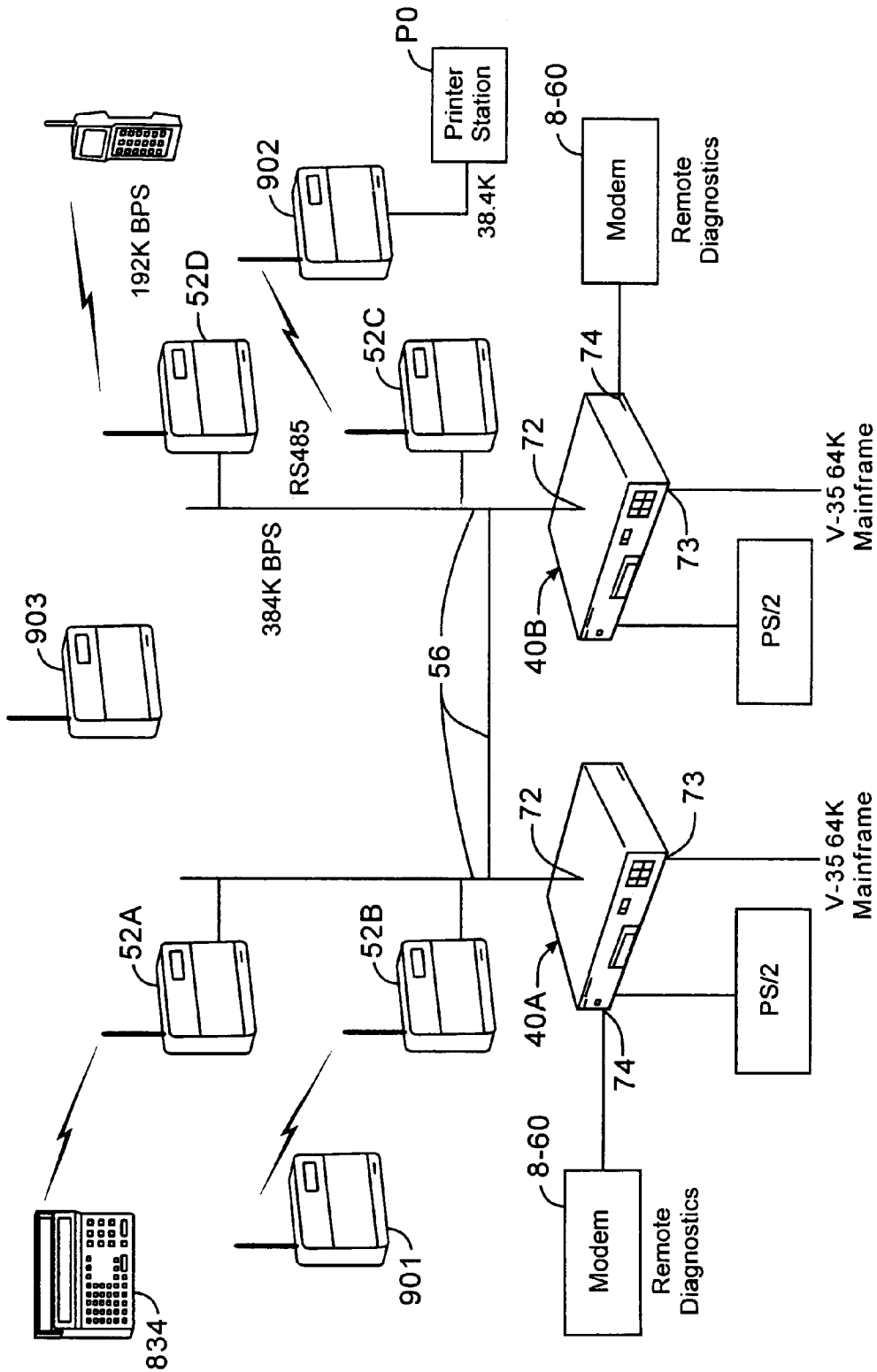

Fig. 9

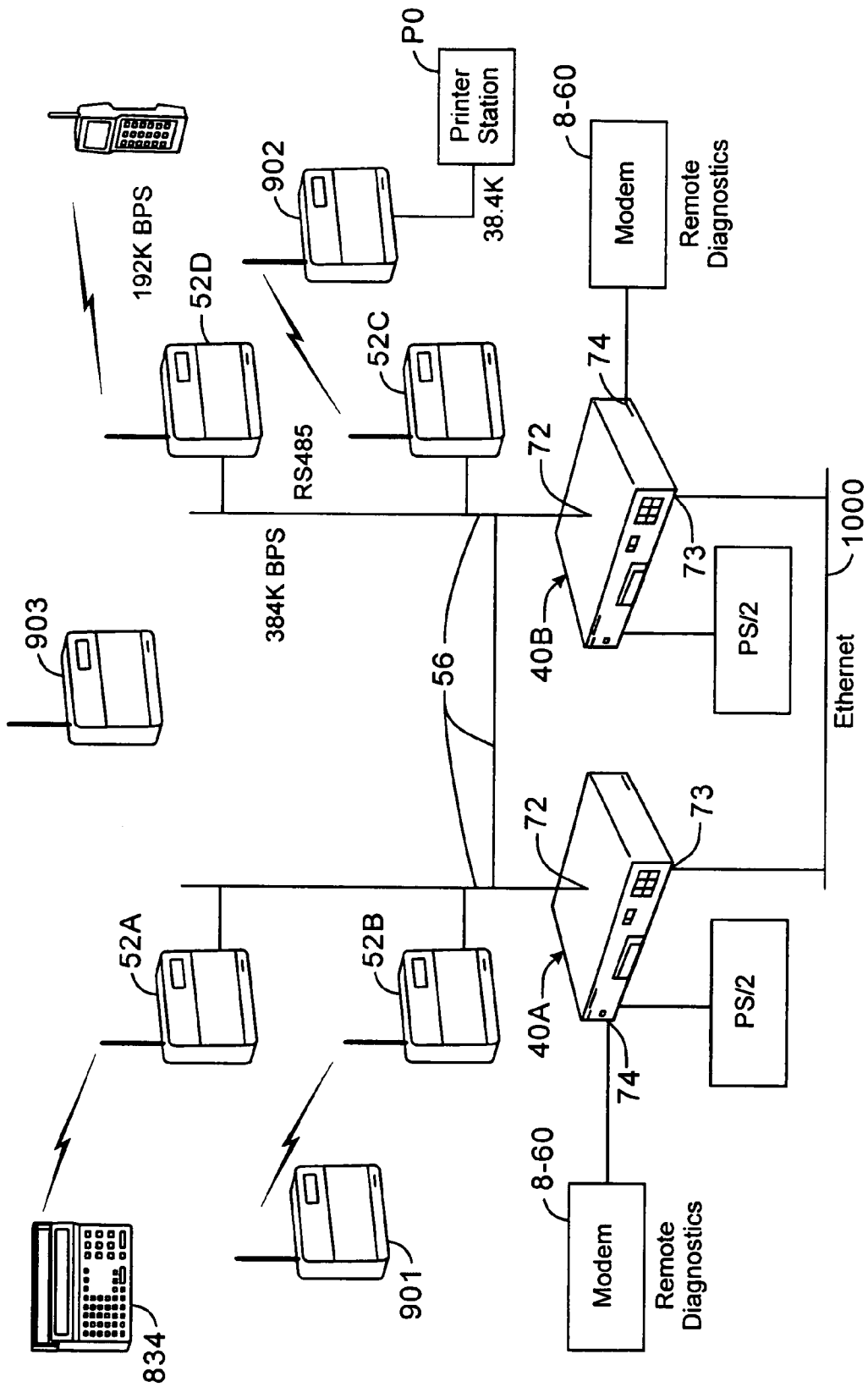

Fig. 10

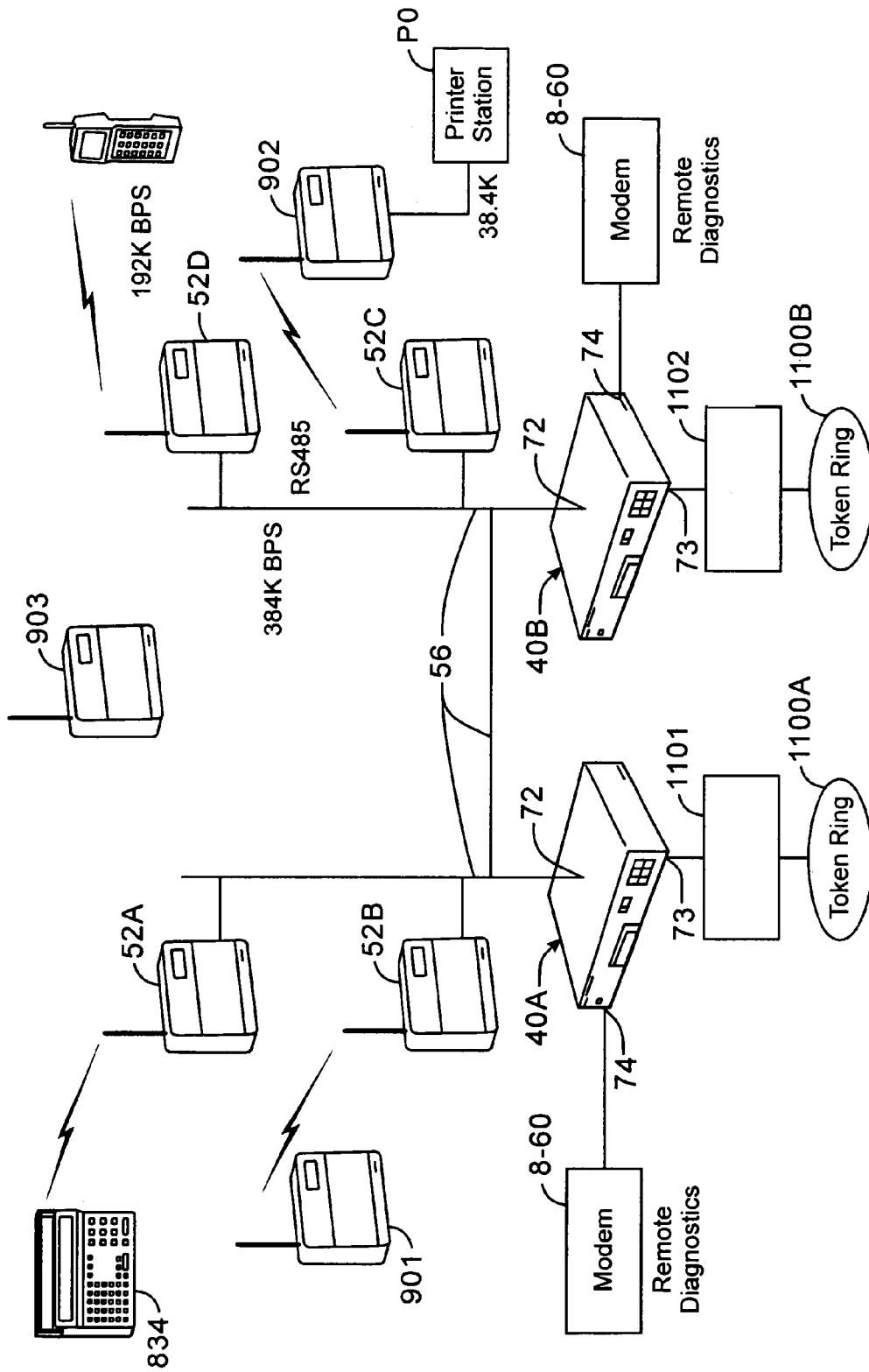

Fig.11

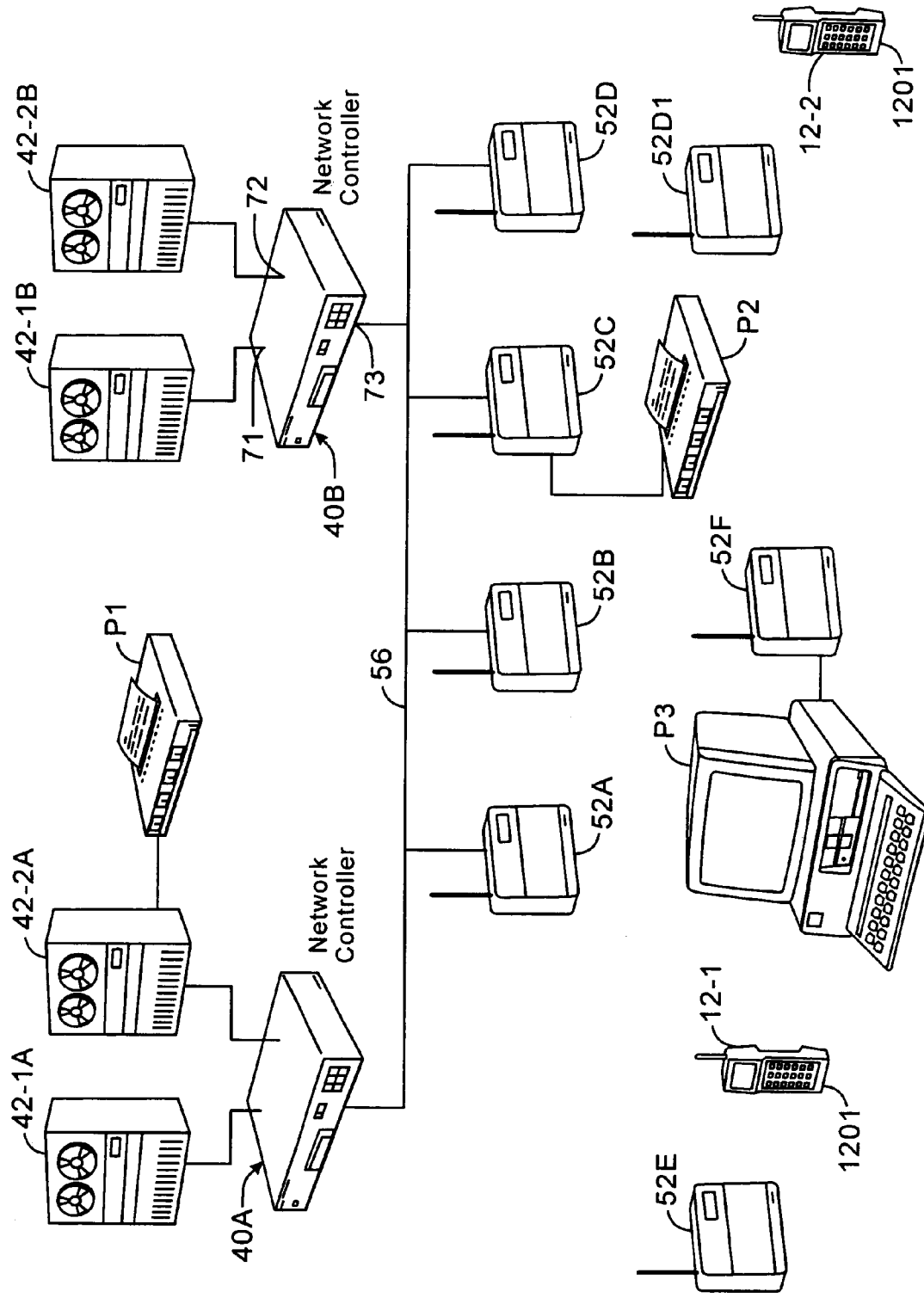

Fig.12

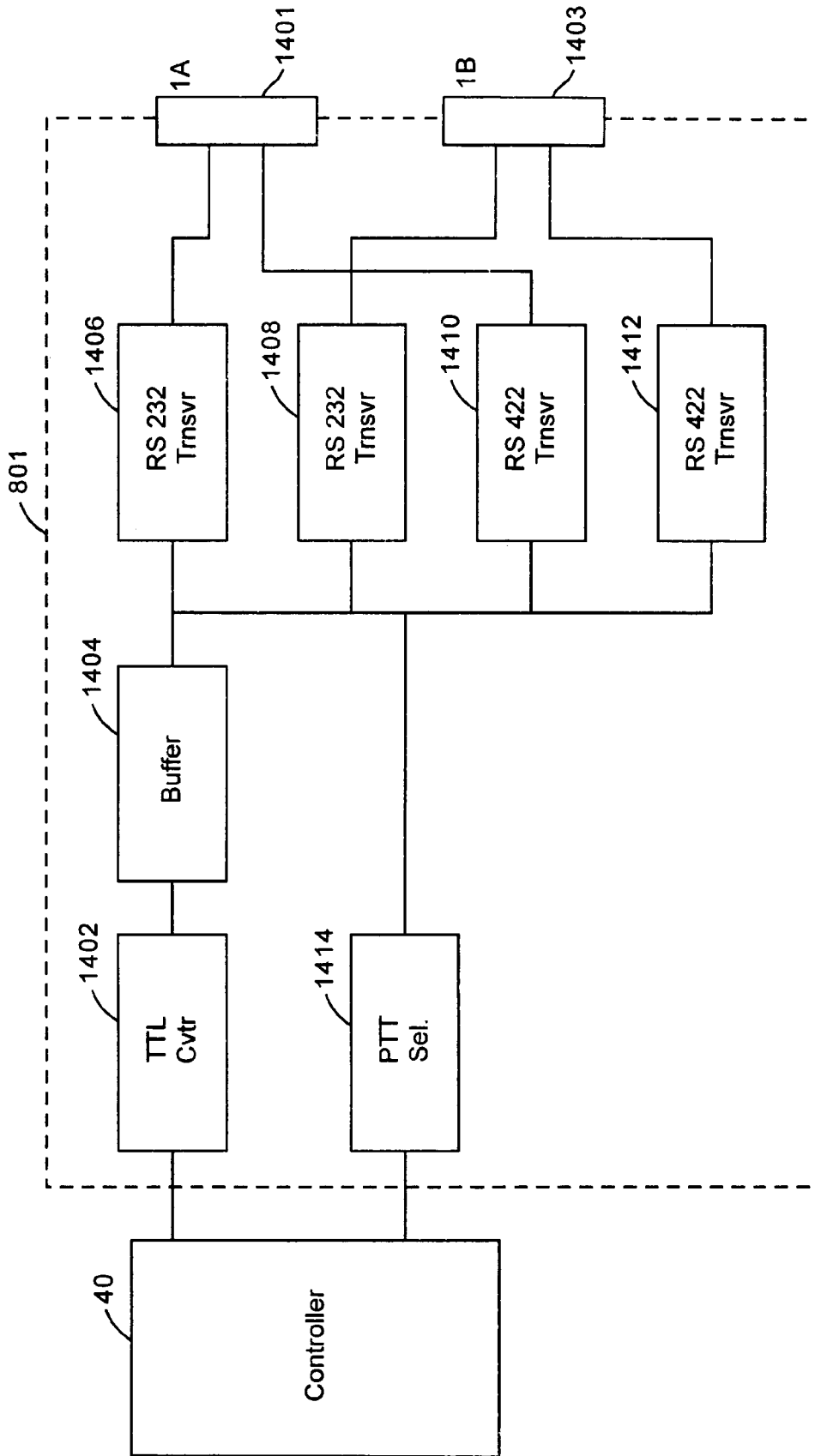

Fig.14

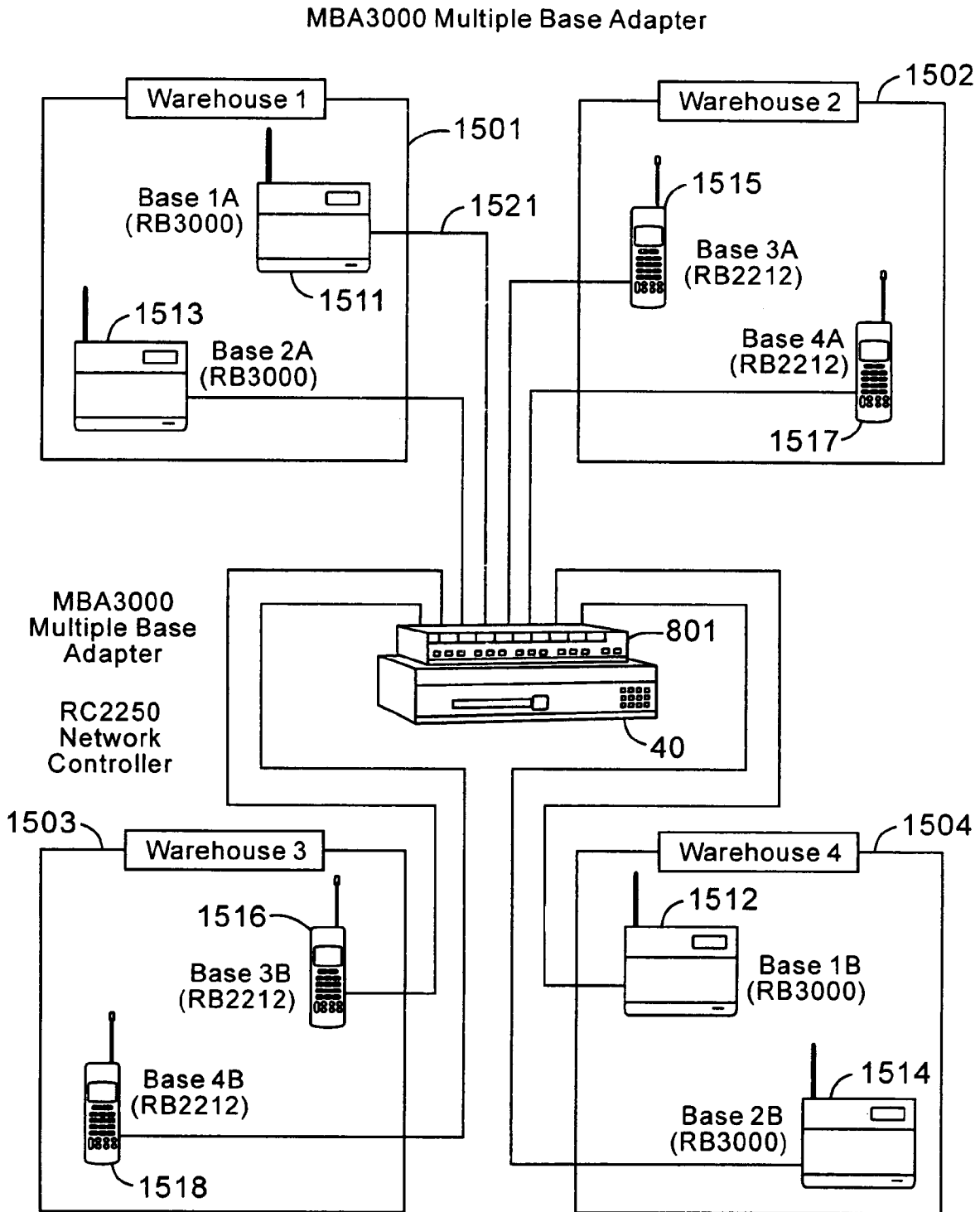

Fig. 15

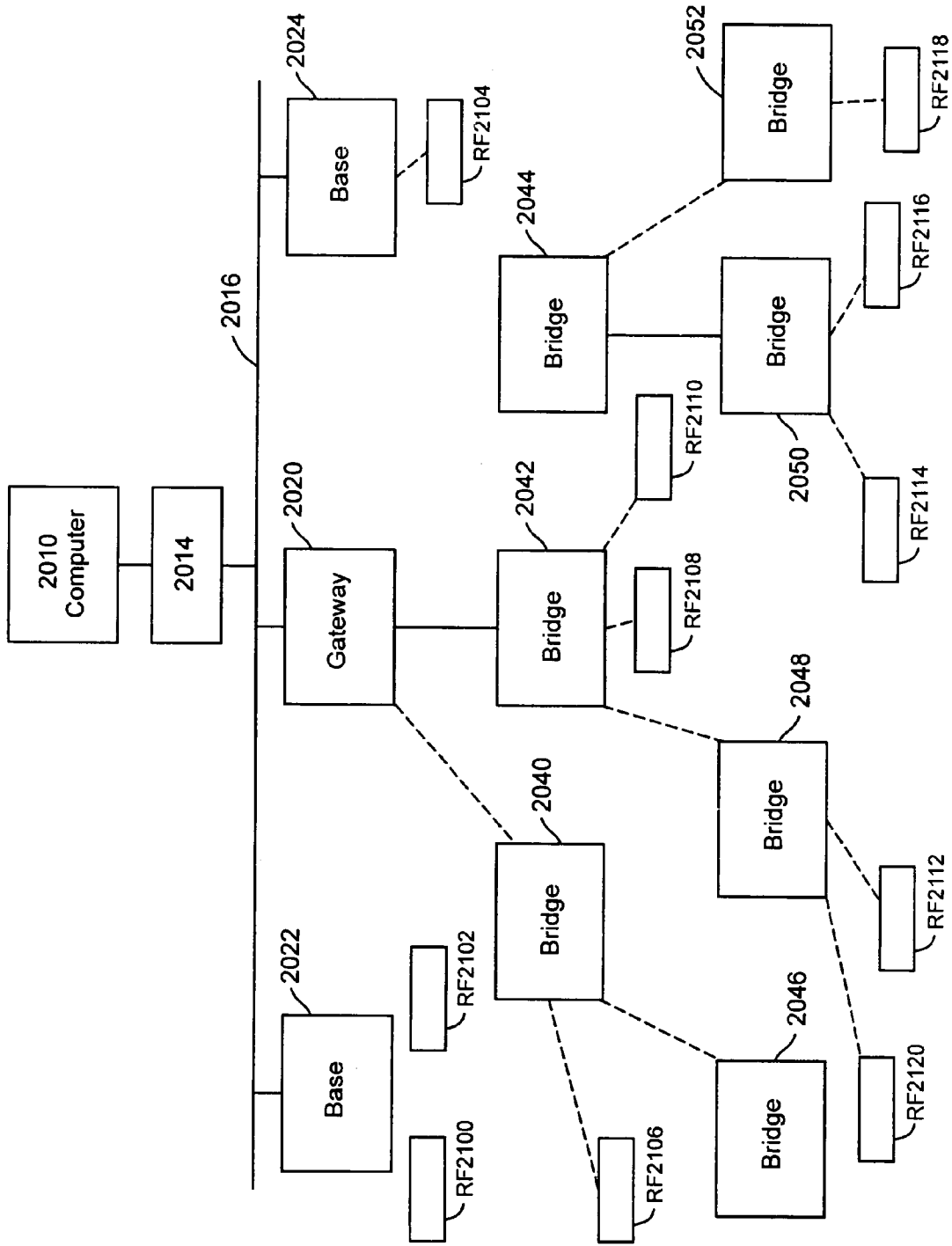

Fig. 16

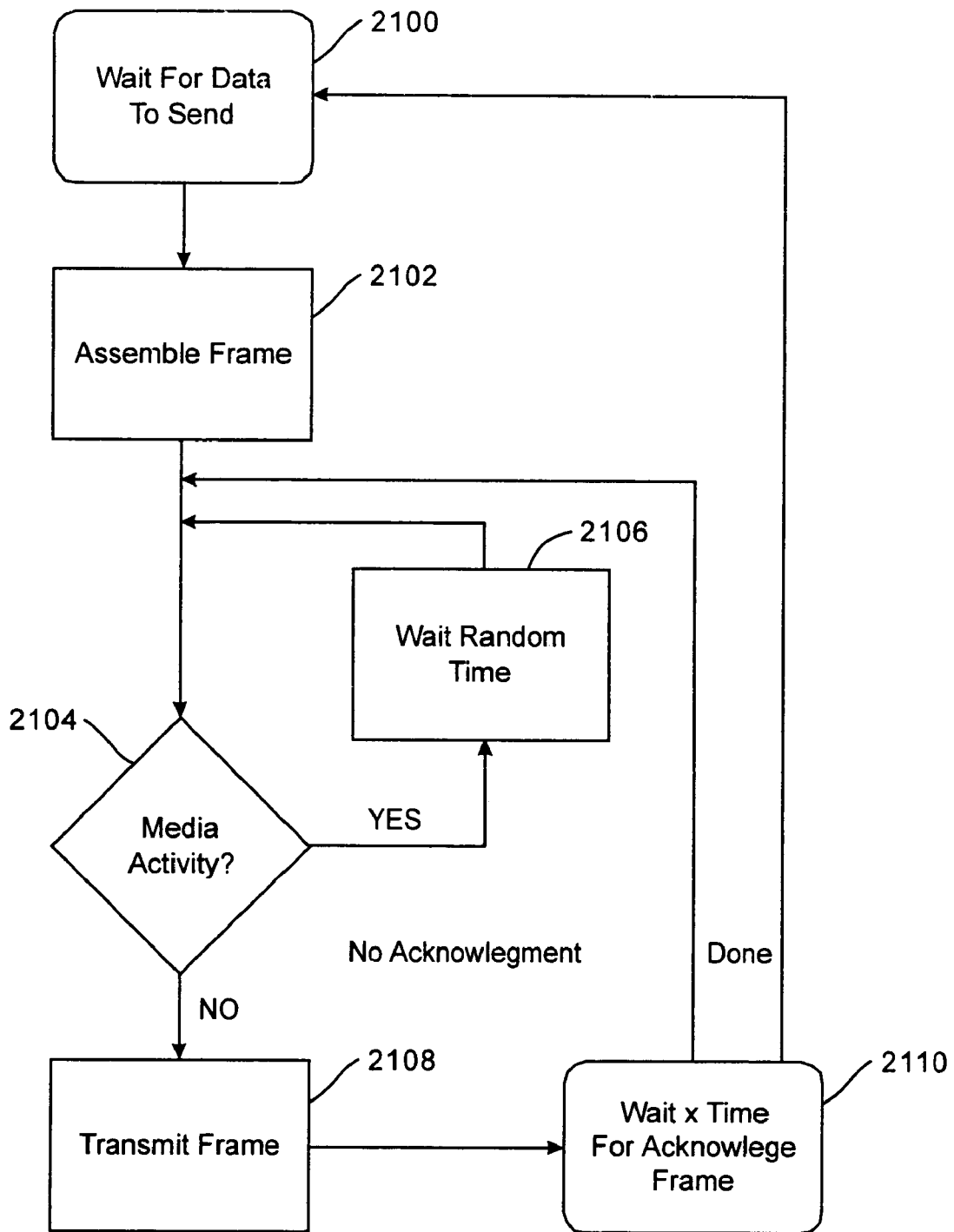

Fig. 17

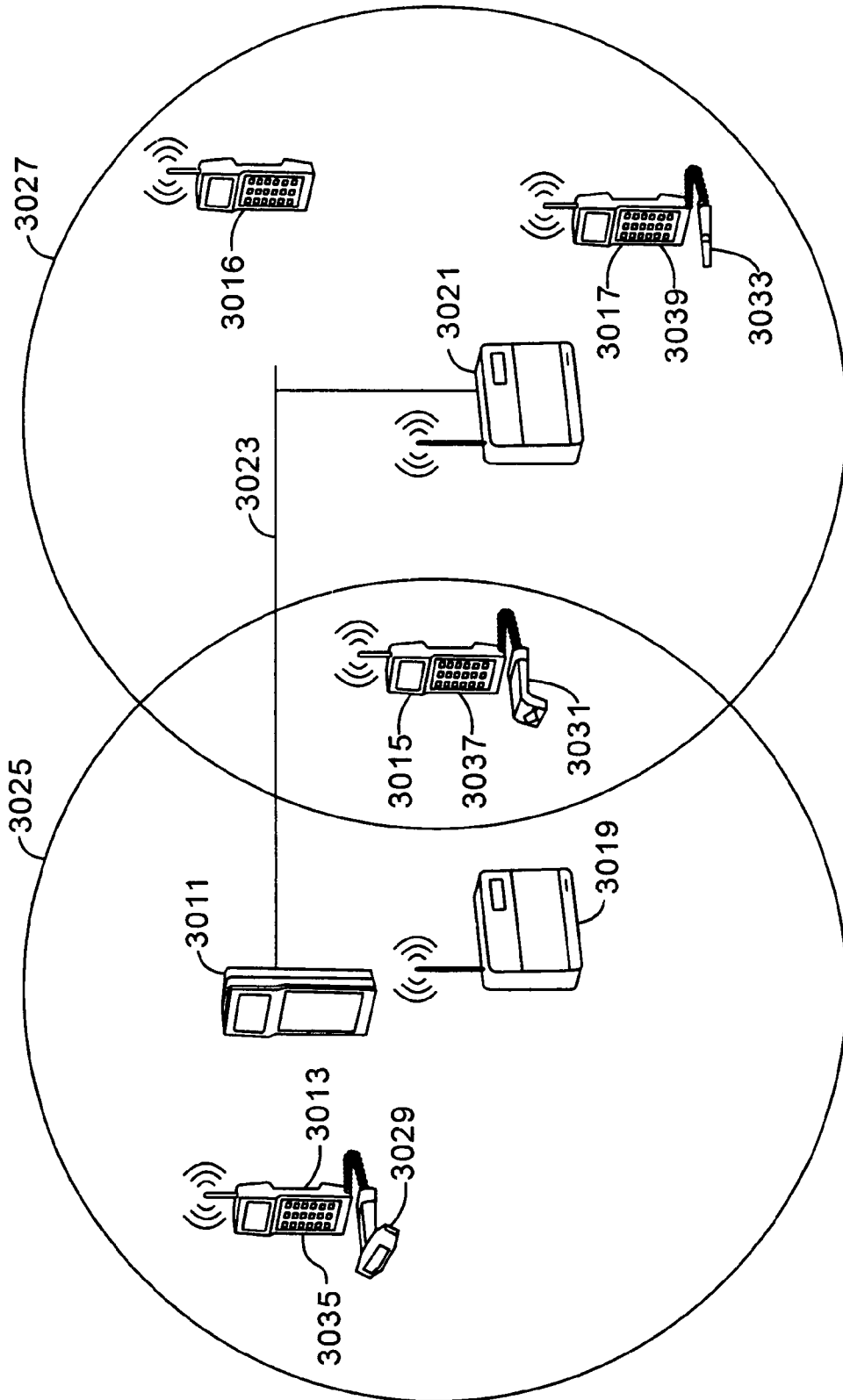

Fig.18

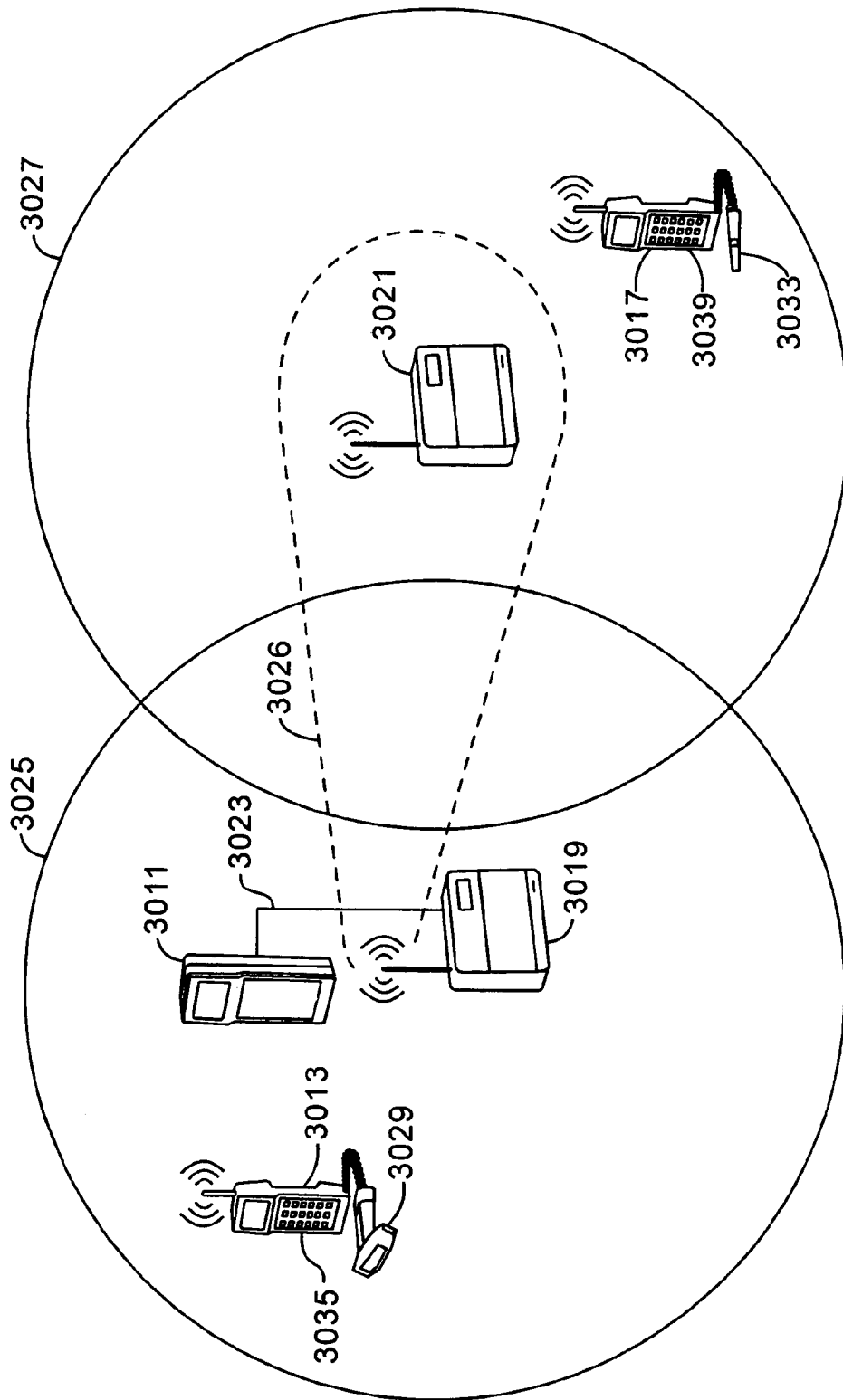

Fig. 18A

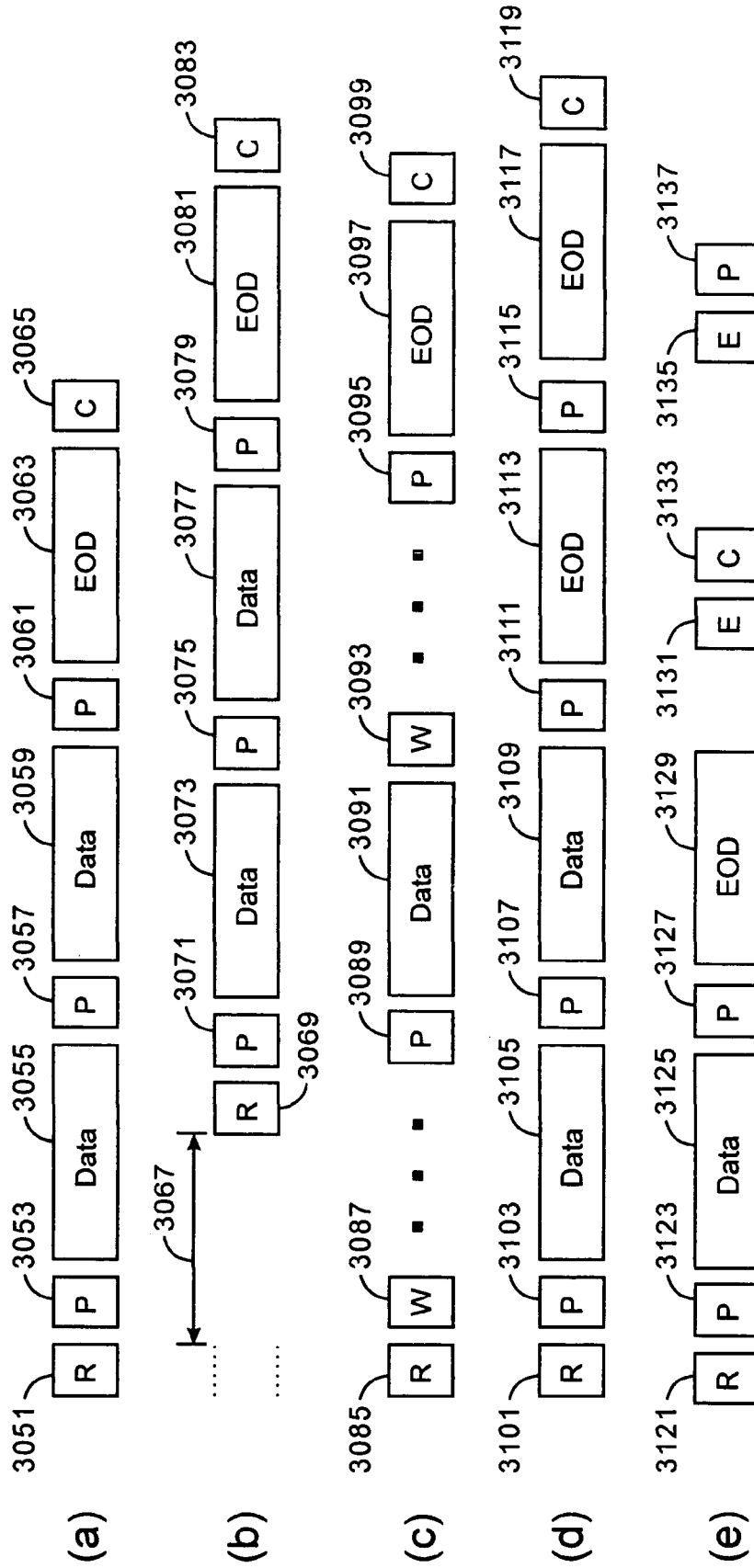

Fig.19

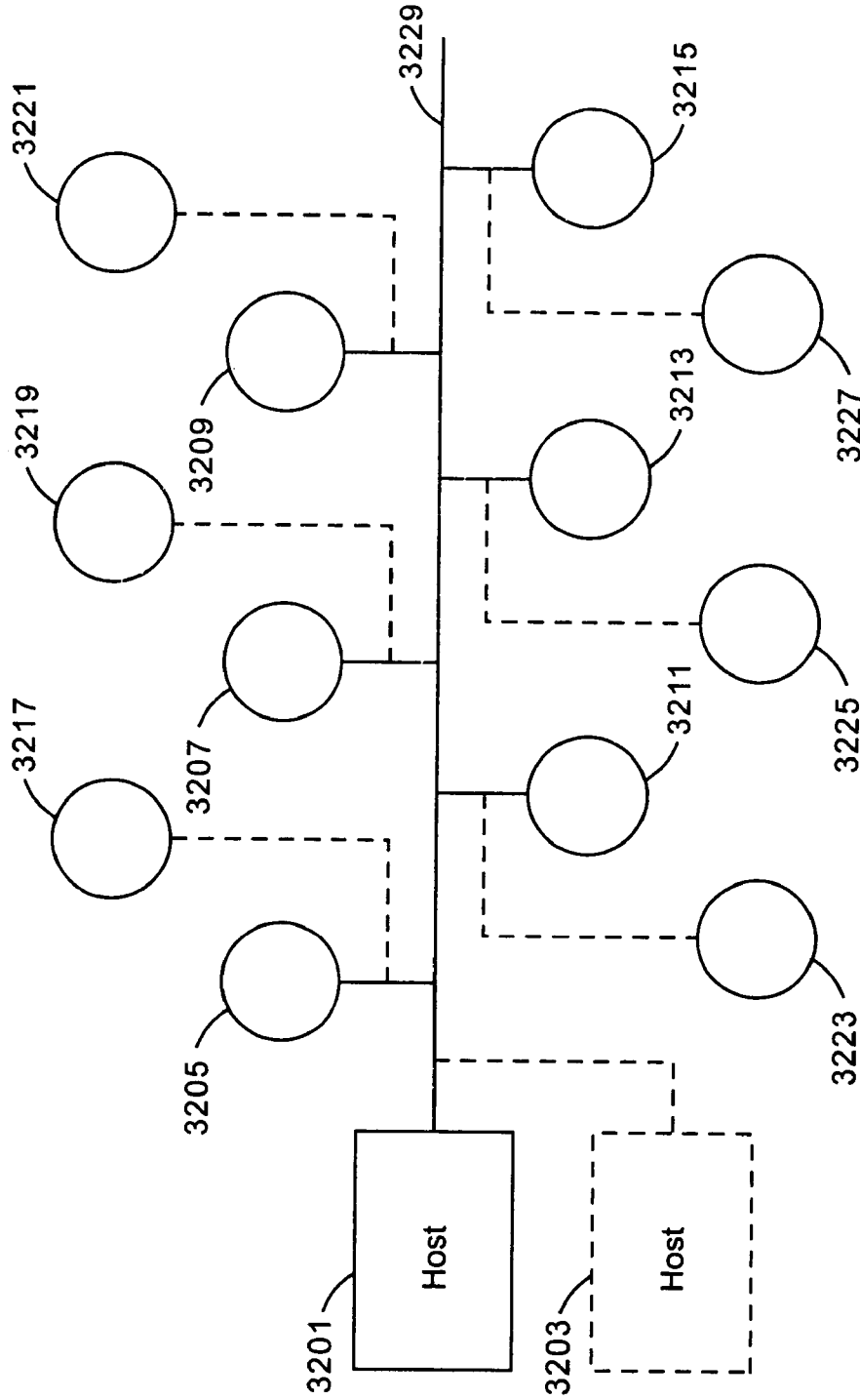

Fig.21

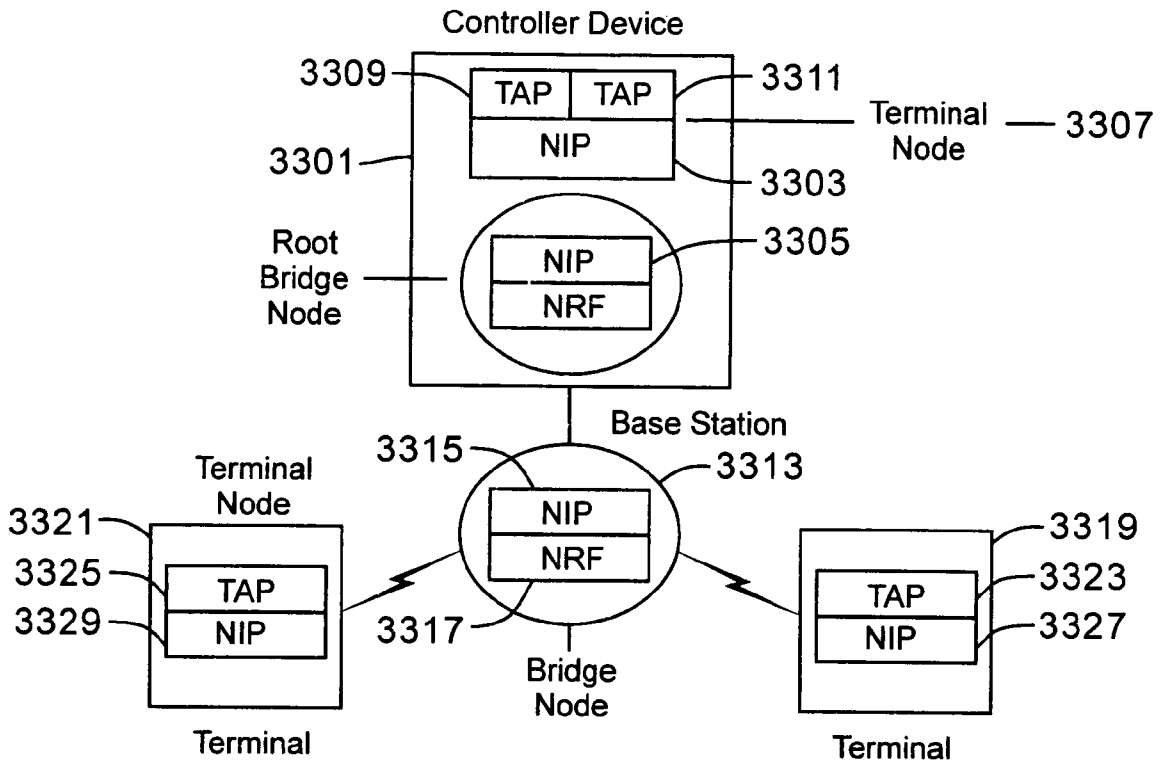

Fig. 22

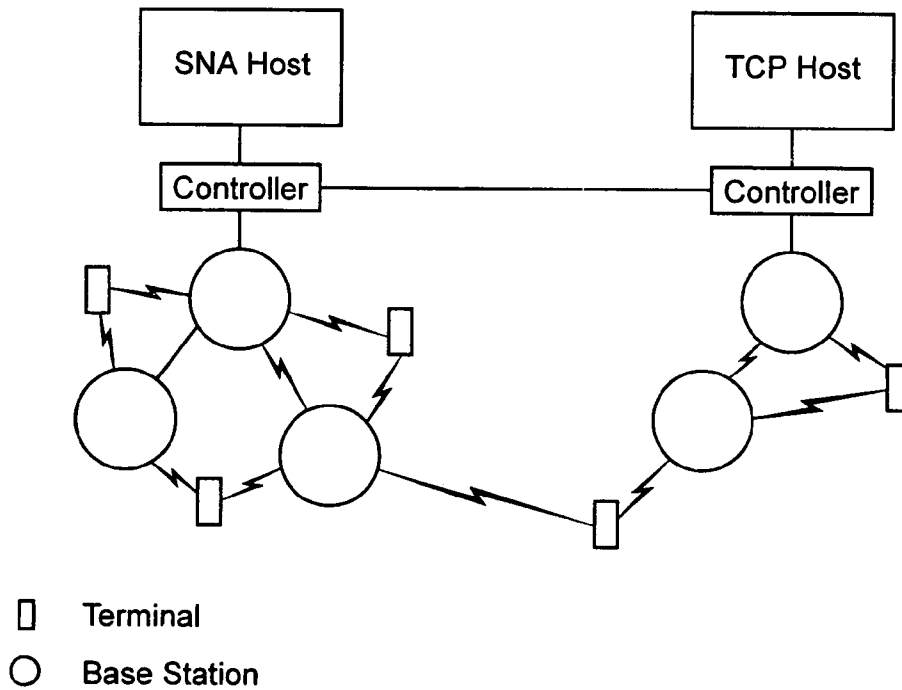

Fig. 23

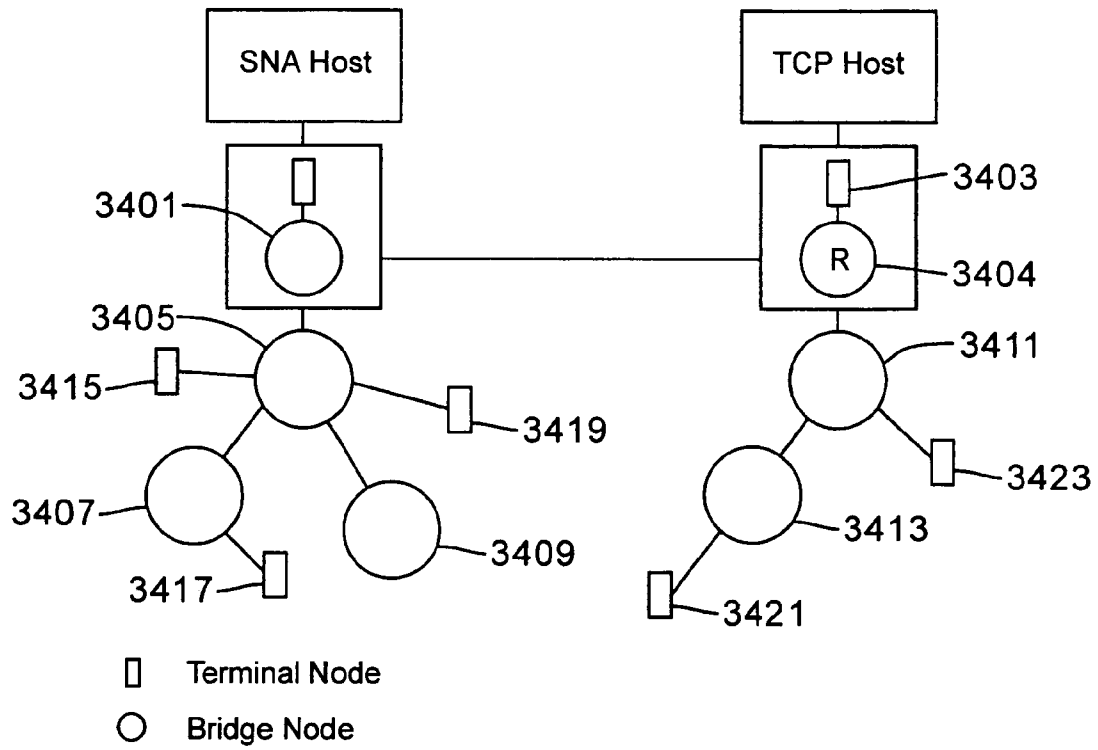

Fig. 24

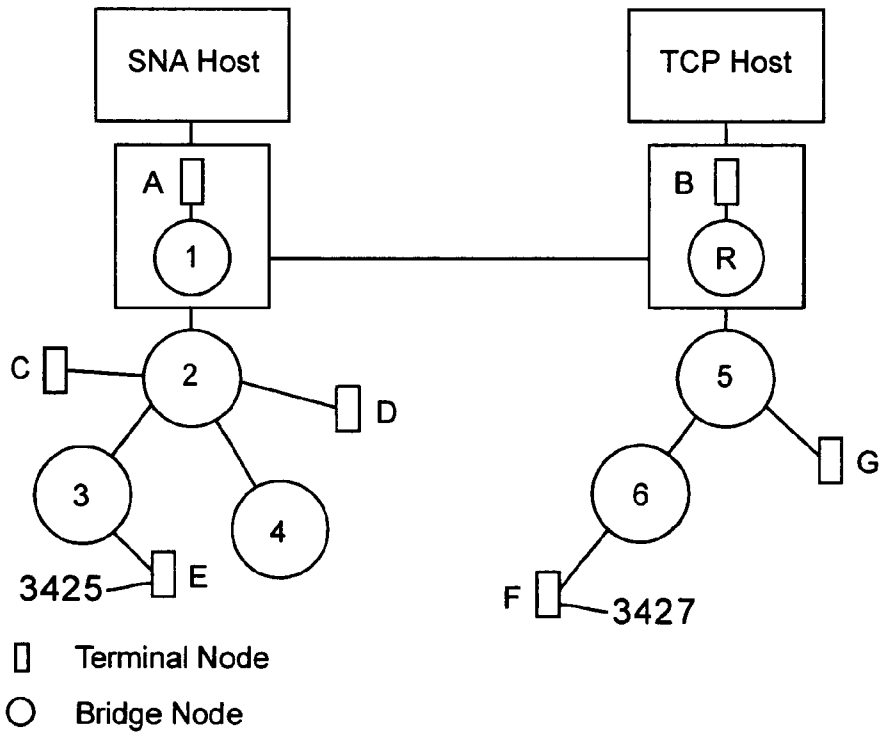

Fig. 25

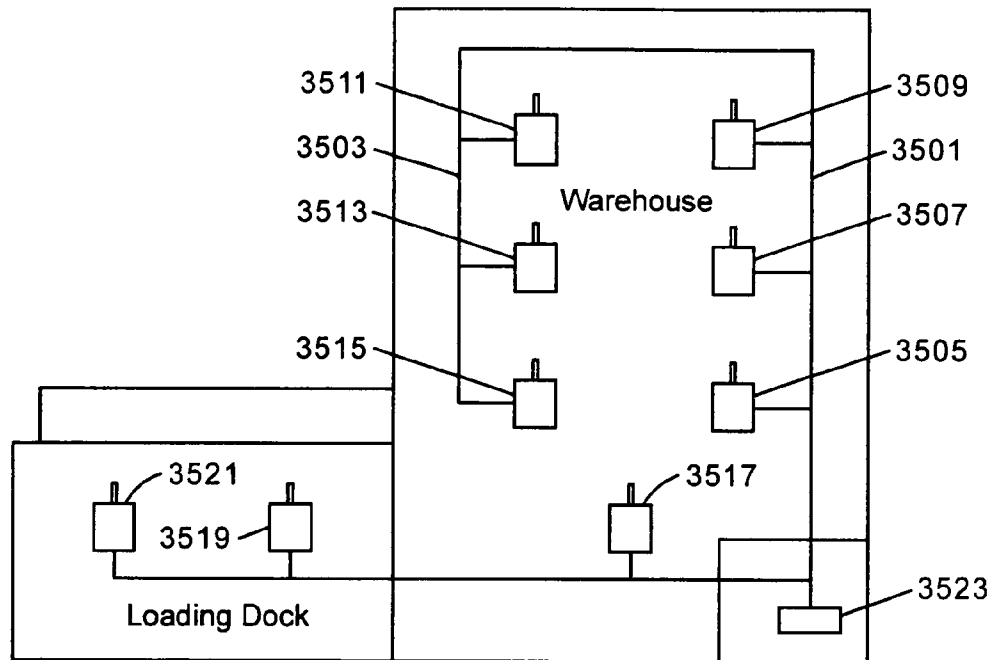

Fig. 26

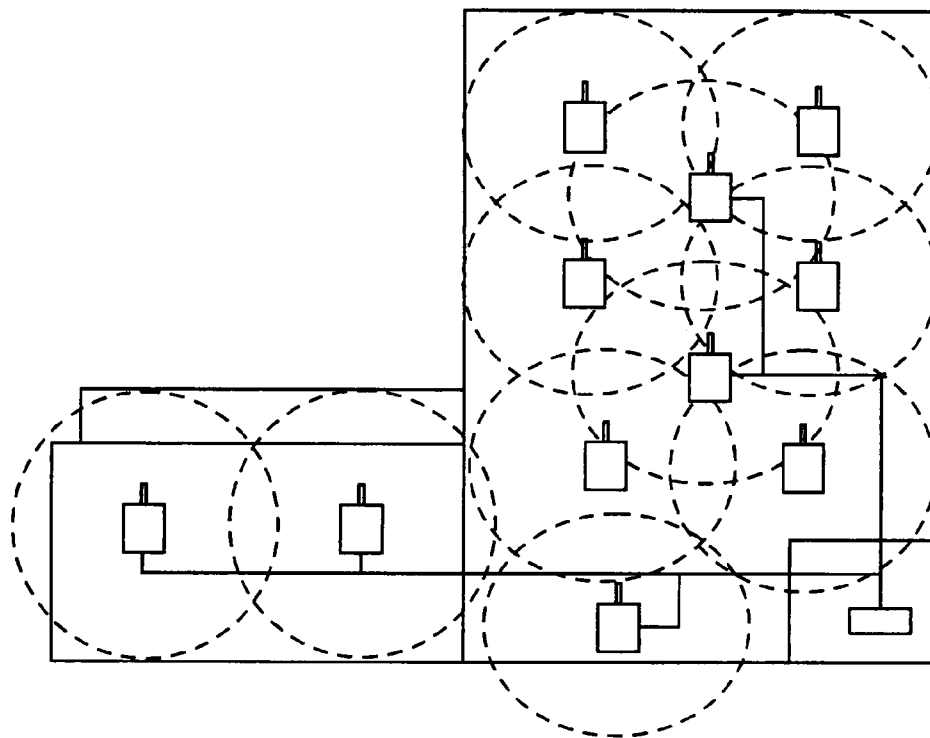

Fig. 27

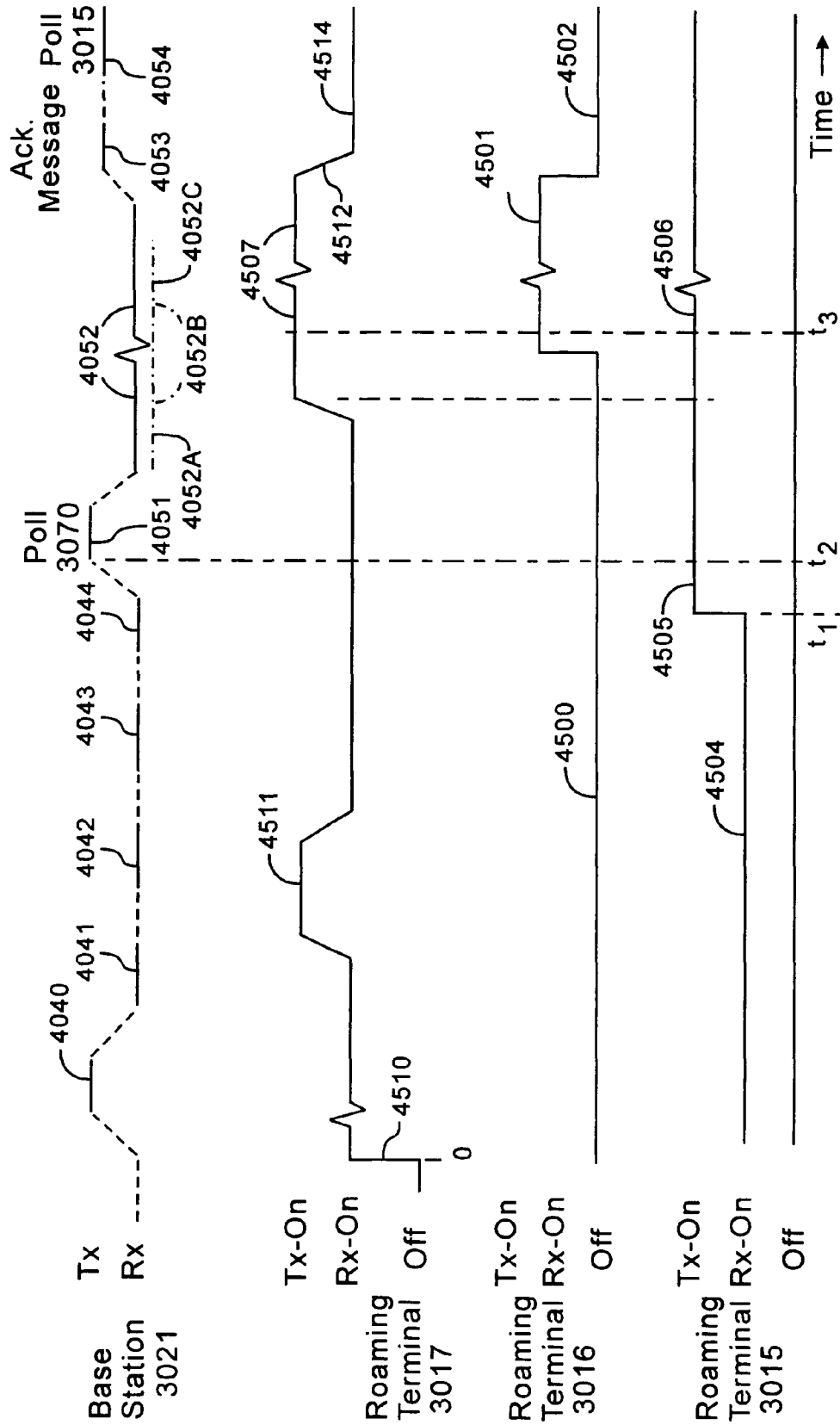
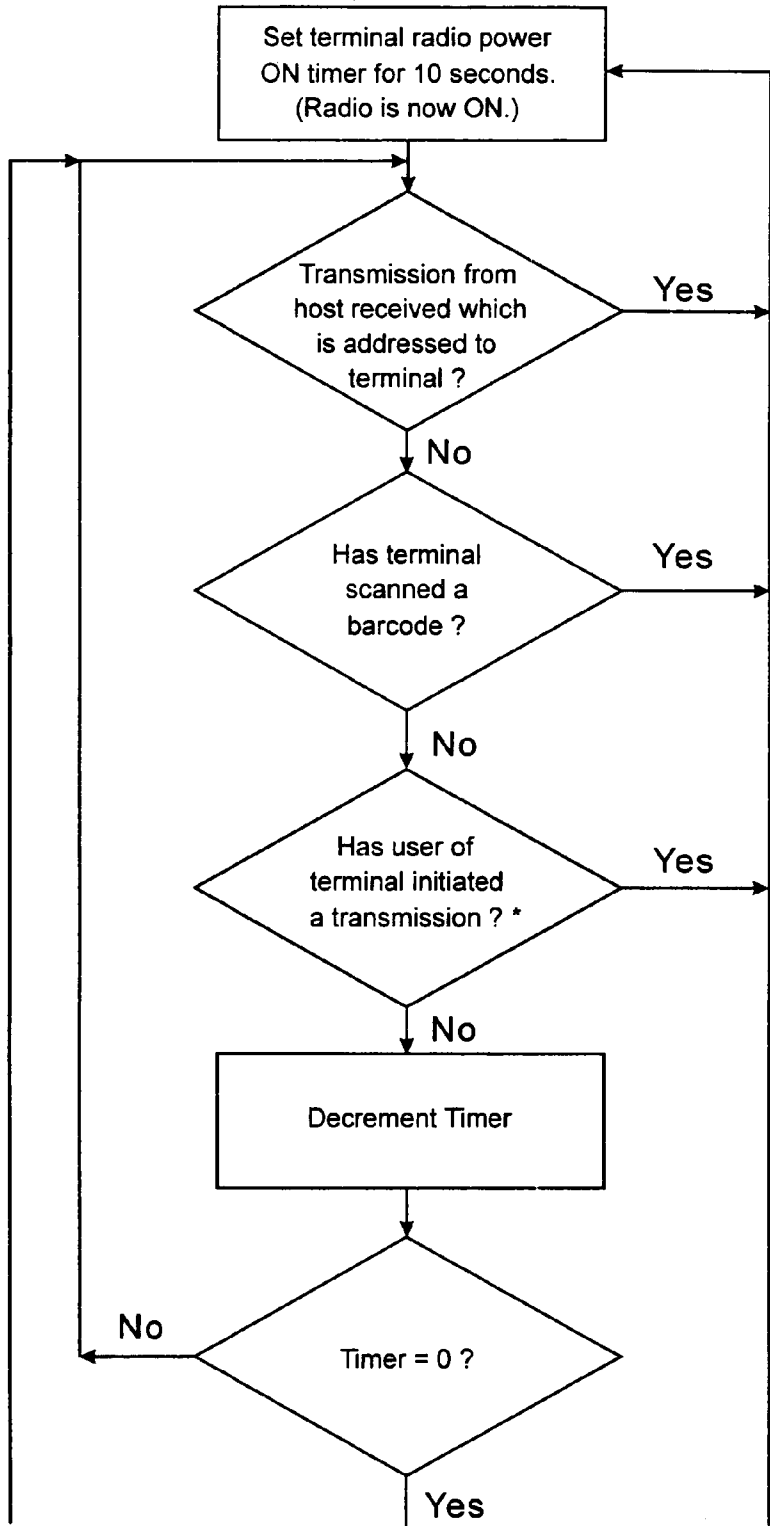

Fig.28



* The user of the terminal initiates a transmission by pressing the 'ENTER' or, depending on the specific software version, any of the function keys. Pressing these keys causes the terminal to power up the radio and send any data entered by the user.

Fig.29

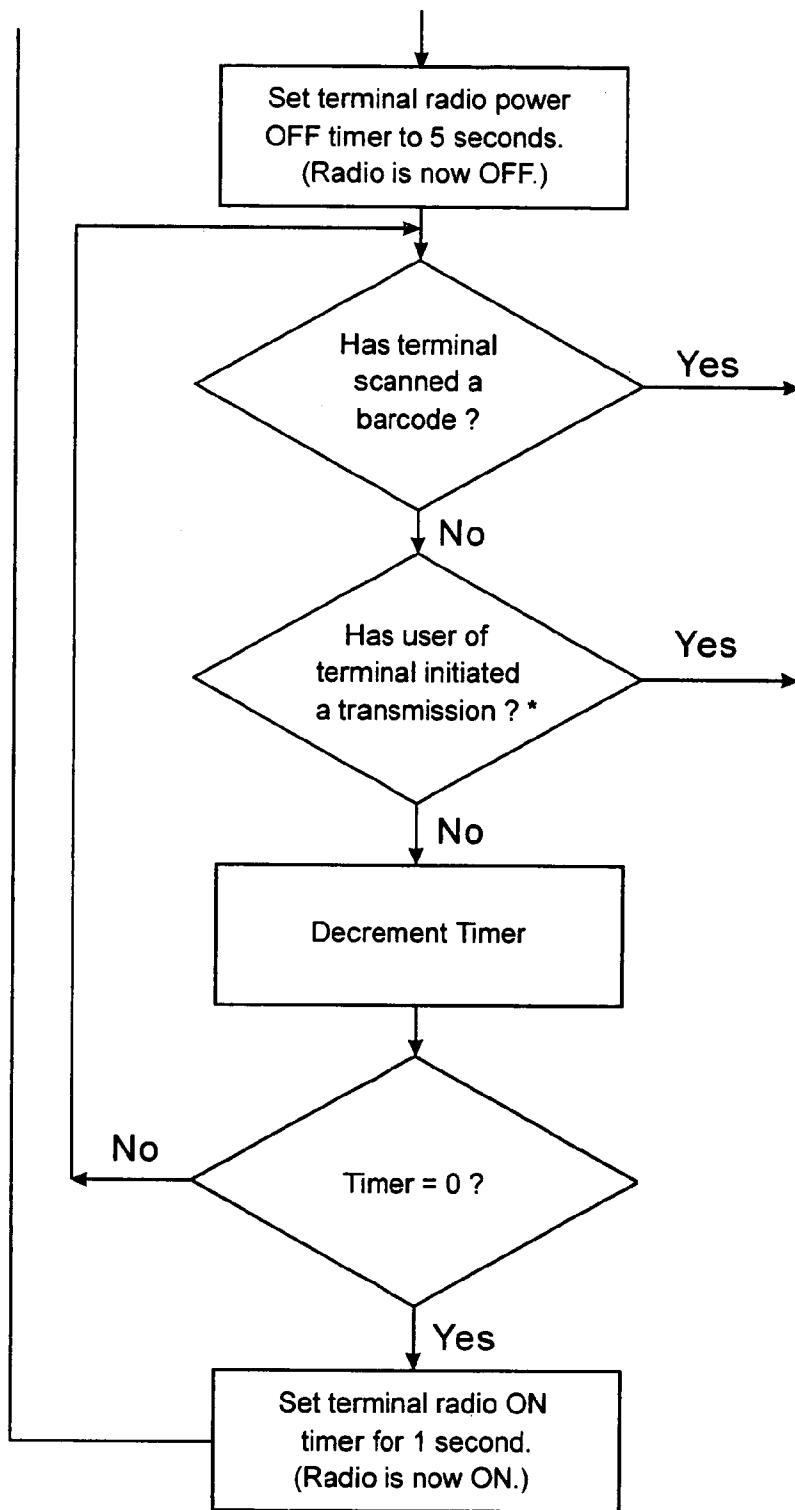

Fig.30