

UNITED STATES DISTRICT COURT  
NORTHERN DISTRICT OF ILLINOIS  
EASTERN DIVISION

VELOCITY PATENT LLC,	)	
	)	
Plaintiff,	)	
v.	)	Case No. 13-cv-8413
	)	
MERCEDES-BENZ USA, LLC;	)	Judge John W. Darrah
MERCEDES-BENZ U.S.	)	
INTERNATIONAL, INC.,	)	
	)	
Defendants.	)	
_____	)	
VELOCITY PATENT LLC,	)	
	)	
Plaintiff,	)	Case No. 13-cv-8419
v.	)	
	)	Judge John W. Darrah
FCA US LLC,	)	
	)	
Defendant.	)	
_____	)	
VELOCITY PATENT LLC,	)	
	)	
Plaintiff,	)	Case No. 13-cv-8418
v.	)	
	)	Judge John W. Darrah
AUDI OF AMERICA, INC.,	)	
	)	
Defendant.	)	

**MEMORANDUM OPINION AND ORDER**

Plaintiff Velocity Patent, LLC (“Velocity”) filed a Complaint against Defendants Mercedes-Benz USA, LLC and Mercedes-Benz U.S. International, Inc. and Amended Complaints against FCA US LLC and Audi of America, Inc., each alleging one count of infringement for several claims of U.S. Patent No. 5,954,781 (“the ‘781 Patent”). On

April 12, 2016, the Court held a claims-construction hearing, which included the argument of counsel for each party and the submissions of written summations by each party. The Court also considered the PowerPoint presentations presented by the parties at the hearing.

## BACKGROUND

The '781 Patent was issued on September 21, 1999. The patent is entitled "METHOD AND APPARATUS FOR OPTIMIZING VEHICLE OPERATION" and describes a system that "notifies the driver of recommended corrections in vehicle operation and, under certain conditions, automatically initiates selected corrective action." ('781 Pat. at 1:7-10.) The patent generally claims several sensors, a memory subsystem, a processor subsystem, and notification circuits.

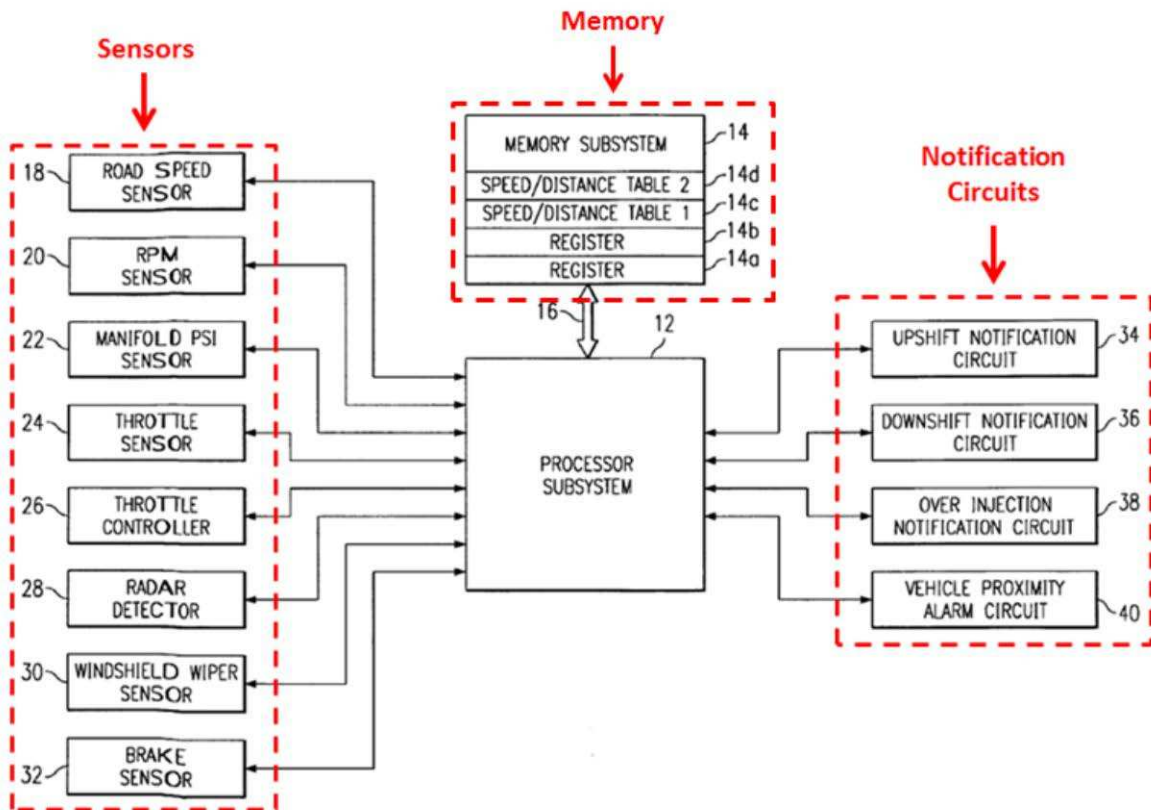

The notification circuits provide warnings to the driver that certain conditions are present. Velocity asserts Claims 1, 7, 13, 17-20, 28, 3-34, 40-42, 46, 53, 56, 58, 60, 64, 66, 69, 75-76, and 88 of the '781 Patent against Defendants.<sup>1</sup>

### LEGAL STANDARD

Claim construction is a question of law. *Markman v. Westview Instruments, Inc.*, 52 F.3d 967, 970 (Fed. Cir. 1995). Claim construction involves “determining the meaning and scope of the patent claims asserted to be infringed.” *Id.* at 976. In construing the claim, the court does not “rewrite claims” but, rather, “give[s] effect to the terms chosen by the patentee.”

*K-2 Corp. v. Salomon S.A.*, 191 F.3d 1356, 1364 (Fed. Cir. 1999). The words of a claim are “generally given their ordinary and customary meaning,” that is, “the meaning that the term would have to a person of ordinary skill in the art in question at the time of the invention.”

*Phillips v. AWH Corp.*, 415 F.3d 1303, 1312-13 (Fed. Cir. 2005) (citations omitted.)

In interpreting claims, “the court should look first to the intrinsic evidence of record, *i.e.*, the patent itself, including the claims, the specification and, if in evidence, the prosecution history.” *Vitronics Corp. v. Conceptoronic, Inc.*, 90 F.3d 1576, 1582 (Fed. Cir. 1996). The specification is “highly relevant to the claim construction analysis,” is “usually . . . dispositive” and is “the single best guide to the meaning of a disputed term.” *Id.* However, limitations from the specification describing embodiments must not be imported into a claim that does not recite those limitations. *Phillips*, 415 F.3d at 1323.

The court may also consider extrinsic evidence, such as expert testimony, dictionaries and learned treatises. *Markman*, 52 F.3d at 980. However, “[e]xtrinsic evidence is to be used for

---

<sup>1</sup> Claims 28, 41, and 88 are not asserted against Mercedes.

the court’s understanding of the patent, not for the purpose of varying or contradicting the terms of the claims.” *Id.* at 981.

**ANALYSIS**

*“Fuel Overinjection Notification Circuit”*

The parties dispute the proper construction of the term “fuel overinjection notification circuit . . . , said fuel overinjection notification circuit issuing a notification that excessive fuel is being supplied to said engine of said vehicle.” This term is located in Claims 1, 7, 13, 17, 28, 60, 69, and 76. The following are the parties’ proposed constructions:

Velocity’s Proposed Construction	Defendants’ Proposed Construction
A circuit that notifies a driver of a reduced fuel economy condition at the time of the condition.	<p><b>Mercedes/FCA:</b> The term “excessive fuel is being supplied to said engine” is indefinite. In the alternative, that term means “more fuel than is proper is being supplied to the engine.”</p> <p><b>Audi:</b> Indefinite</p>

Indefiniteness

Defendants argue that this term is indefinite. A patent must “conclude with one or more claims particularly pointing out and distinctly claiming the subject matter which the applicant regards as [the] invention.” 35 U.S.C. § 112, ¶ 2. A lack of definiteness renders the patent or any claim in suit invalid. 35 U.S.C. § 282, ¶ 2(3).1. “[A] patent is invalid for indefiniteness if its claims, read in light of the specification delineating the patent, and the prosecution history, fail to inform, with reasonable certainty, those skilled in the art about the scope of the invention.” *Nautilus, Inc. v. Biosig Instruments, Inc.*, 134 S. Ct. 2120, 2124 (2014).

“Some modicum of uncertainty . . . is the ‘price of ensuring the appropriate incentives for innovation.’” *Id.* at 2128 (quoting *Festo Corp. v. Shoketsu Kinzoku Kogyo Kabushiki Co.*, 535

U.S. 722, 732 (2002)). However, “a patent must be precise enough to afford clear notice of what is claimed, thereby appris[ing] the public of what is still open to them.” *Id.* at 2129. “The properties and purpose of the invention, together with the examples provided by the specification, [must] apprise an ordinary-skilled artisan of the scope of the invention.”

*Delaware Display Grp. LLC v. Lenovo Grp. Ltd*, No. CA 13-2108-RGA, 2015 WL 6870031, at \*6 (D. Del. Nov. 6, 2015). “[T]he burden of proving indefiniteness remains on the party challenging [the patent’s] validity and that they must establish it by clear and convincing evidence.” *Dow Chem. Co. v. Nova Chemicals Corp. (Canada)*, 809 F.3d 1223, 1227 (Fed. Cir. 2015).

Plaintiff argues that the “fuel overinjection notification circuit” does not contain a term of degree and is not indefinite because the claim provides for a notification. However, the notification is activated when “excessive fuel” is being supplied to the engine and “excessive fuel” is a term of degree. However, terms of degree are not “inherently indefinite.”

*Interval Licensing LLC v. AOL, Inc.*, 766 F.3d 1364, 1370 (Fed. Cir. 2014), *cert. denied*, 136 S. Ct. 59, 193 L. Ed. 2d 207 (2015). A term of degree provides insufficient notice of its scope if it depends “on the unpredictable vagaries of any one person’s opinion.” *Id.* at 1371 (citing

*Datamize, LLC v. Plumtree Software, Inc.*, 417 F.3d 1342, 1350 (Fed. Cir. 2005)). In *Interval Licensing*, the patents described a system that selectively displayed generated images “in an unobtrusive manner that does not distract a user of the display device . . . .”

*Interval Licensing LLC*, 766 F.3d 1364, 1368. The Federal Circuit found the claim term “unobtrusive manner” indefinite, referencing the term’s highly subjective nature and its failure to provide guidance to one of skill in the art. *Id.* at 1371. Whether an image was obtrusive depended on the preferences of any particular viewer and the circumstances under which the

image was viewed. *Id.* Thus, the patent did not provide enough guidance to one practiced in the art.

In *Teva Pharm. USA, Inc. v. Sandoz, Inc.*, 789 F.3d 1335 (Fed. Cir. 2015), the claim limitation at issue recited the term “molecular weight” without specifying the meaning of that term. *Teva*, 789 F.3d at 1341. The patentee argued that average molecular weight had a presumed meaning in the context of the patent. *Id.* However, the Court held that the claims were indefinite because there were multiple relevant measures for molecular weight and that “the claim on its face offers no guidance on which measure of ‘molecular weight’ the claims cover.” *Id.* “The burden of proving indefiniteness includes proving not only that multiple measurement techniques exist, but that one of skill in the art would not know how to choose among them.” *Dow Chem. Co.*, 809 F.3d at 1227.

The ‘781 patent describes itself as claiming an “[a]pparatus for optimizing operation of an engine driven vehicle.” (‘781 Pat.) Further, the specification notes that “operating a vehicle at excessive speed, excessive RPM and/or excessive manifold pressure will result in both reduced fuel economy and increased operating costs,” and that the purpose of the invention is to provide a system “which will enhance the efficient operation” of the vehicle. (‘781 Pat. at 1:15-18; 2:2-3). The intrinsic record also shows that the ‘781 patent was meant to promote efficient operation of a vehicle in terms of fuel efficiency and fuel economy. See, *e.g.*, (JA 112, 260, 337.)

Defendants argue that the patent “must identify (1) a standard to measure the relative term (*e.g.*, how the amount of fuel being supplied to the engine should be measured) and (2) an objective boundary (*e.g.*, a point of reference used to determine whether an amount of fuel [is] ‘excessive’).” (Defs’ Br. at p. 5.) However, a claim does not necessarily need to reference a

precise numerical measurement. *See Enzo Biochem, Inc. v. Applera Corp.*, 599 F.3d 1325, 1335 (Fed. Cir. 2010) (“Because the intrinsic evidence here provides a general guideline and examples sufficient to enable a person of ordinary skill in the art to determine [the scope of the claims], . . . , the claims are not indefinite even though the construction of the term ‘not interfering substantially’ defines the term without reference to a precise numerical measurement.”) (internal citations and quotations omitted)). Furthermore, the lack of a standard to measure the amount of fuel being supplied to the engine speaks to the breadth of the patent. A broad claim does not “prevent the public from understanding the scope of the patent.” *Ultimax Cement Mfg. Corp. v. CTS Cement Mfg. Corp.*, 587 F.3d 1339, 1352 (Fed. Cir. 2009); *SmithKline Beecham Corp. v. Apotex Corp.*, 403 F.3d 1331, 1341 (Fed. Cir. 2005) (“[B]readth is not indefiniteness.” (quotation and citation omitted)). “A broad claim can be definite even where there is no precise numerical boundary so long as a person of skill in the art can determine the scope with reasonable certainty.” *GPNE Corp. v. Apple Inc.*, 108 F. Supp. 3d 839, 874 (N.D. Cal. 2015) (citing *Enzo Biochem, Inc.*, 599 F.3d at 1335; *Nautilus*, 134 S. Ct. at 2124).

Further, the patent itself contains examples of when the “fuel overinjection notification circuit” should be activated. For example, the fuel overinjection notification circuit is activated when: (1) road speed and throttle position for the vehicle are increasing; and (2) manifold pressure for the vehicle is above the manifold pressure set point. (’781 Pat. at 2:19-27.) The fuel overinjection notification circuit is activated if both (1) throttle position and manifold pressure for the vehicle are increasing; and (2) road speed and engine speed for the vehicle are decreasing. (*Id.* at 2:28-36). “[A] patent which defines a claim phrase through examples may satisfy the definiteness requirement.” *Interval Licensing LLC*, 766 F.3d at 1373; *see also*

*DDR Holdings, LLC v. Hotels.com, L.P.*, 773 F.3d 1245, 1260 (Fed. Cir. 2014) (“For other terms like, for example, terms of degree, specific and unequivocal examples may be sufficient to provide a skilled artisan with clear notice of what is claimed.”). These examples provide a method of measurement or assessment.

The patent provides a general guideline and examples sufficient to enable a person of ordinary skill in the art to determine the scope of the claims. Defendants have not shown, by clear and convincing evidence, that the ‘781 Patent fails to inform, with reasonable certainty, an individual skilled in the art about the scope of the invention in light of the specification and the prosecution history. The term “excessive fuel” is not indefinite under the *Nautilus* test.

#### Construction

Mercedes and FCA argue that, in the alternative to the term being indefinite, “excessive fuel” should be construed as “more fuel than is proper is being supplied to the engine.” The entire phrase would be “fuel overinjection notification circuit . . . , said fuel overinjection notification circuit issuing a notification that more fuel than is proper is being supplied to the engine of said vehicle.” Plaintiff’s proposed construction is: “A circuit that notifies a driver of a reduced fuel economy condition at the time of the condition.”

The words of a claim are “generally given their ordinary and customary meaning,” that is, “the meaning that the term would have to a person of ordinary skill in the art in question at the time of the invention.” *Phillips*, 415 F.3d at 1312-13. Additionally, a “claim construction that gives meaning to all the terms of the claim is preferred over one that does not do so.”

*Merck & Co. v. Teva Pharm. USA, Inc.*, 395 F.3d 1364, 1372 (Fed. Cir. 2005). Plaintiff argues that Mercedes and FCA’s construction would read out the preferred embodiment of the claim because there is no description of a way to measure the amount of fuel being supplied to the



engine. Defendants respond that the fuel does not need to be measured directly but can be measured indirectly by proxies, *i.e.*, the various sensors described in the patent. This is one of the arguments Plaintiff makes as to why the notification of excessive fuel use is not indefinite, because it is based on data measured by the sensors. Defendants' construction does not read out the preferred embodiment.

Specifications are the "primary basis for construing the claims." *Phillips*, 415 F.3d at 1315 (quoting *Standard Oil Co. v. Am. Cyanamid Co.*, 774 F.2d 448, 452 (Fed.Cir.1985)). However, limitations from the specification describing embodiments must not be imported into a claim that does not recite those limitations. *Phillips*, 415 F.3d at 1323. Therefore, it would be improper to read a notification of fuel efficiency, which is only located in dependent Claim 42<sup>2</sup>, into a claim that does not recite that limitation. According to the Merriam-Webster dictionary, excessive is defined as "exceeding what is usual, proper, necessary, or normal." However, Defendants' use of the word "proper" does not adequately describe the claim. Efficiency is based on how much of something is *necessary* to complete a particular task.

The Court adopts the following construction for the term "fuel overinjection notification circuit . . . , said fuel overinjection notification circuit issuing a notification that excessive fuel is being supplied to said engine of said vehicle": A circuit that notifies a driver that more fuel is being supplied to the engine than is necessary.

---

<sup>2</sup> Claim 42 recites an: "Apparatus for optimizing operation of a vehicle according to claim 1, wherein said notification that excessive fuel is being supplied to said engine of said vehicle notifies a driver that the vehicle is not being operated fuel efficiently." (JA 670, 2:9-12.)

*“Insufficient Engine Speed”*

The parties dispute the proper construction of the term “insufficient engine speed” in Claims 7 and 13. The following are the parties’ proposed constructions:

Velocity’s Proposed Construction	Defendants’ Proposed Construction
Engine rotation speed falls below a threshold	Indefinite

Defendants argue that this term is also indefinite because there is no objective boundary. As previously discussed, a “claim can be definite even where there is no precise numerical boundary so long as a person of skill in the art can determine the scope with reasonable certainty.” *GPNE Corp.*, 108 F. Supp. 3d at 874. Further, other parts of the patent make reference to manufacturers’ guidelines for engine-specific thresholds. While the patent does not point to specific threshold, “[s]ome modicum of uncertainty . . . is the ‘price of ensuring the appropriate incentives for innovation.’” *Nautilus, Inc.*, 134 S. Ct. at 2128 (quoting *Festo Corp.*, 535 U.S. at 732.) For the reasons discussed above, Defendants have not shown, by clear and convincing evidence, that the ‘781 Patent fails to inform, with reasonable certainty, an individual skilled in the art about the scope of the invention in light of the specification and the prosecution history.

The Court adopts the following construction for the term “insufficient engine speed”:  
Engine rotation speed falls below a threshold.

*“A Processor Subsystem . . . Said Processor Subsystem Determining . . .”*

The parties dispute the proper construction of the phrase, “a processor subsystem . . . said processor subsystem determining . . .” in Claims 1, 7, 13, 17, 60, 69, and 76. The following are the parties’ proposed constructions:

Velocity's Proposed Construction	Defendants' Proposed Construction
The term is not governed by 35 U.S.C. § 112 ¶ 6. The term does not require further construction.	The term is governed by 35 U.S.C. § 112 ¶ 6.

Defendants argue that the term “processor subsystem” is governed by 35 U.S.C. § 112(f), formerly § 112 ¶ 6, which states:

An element in a claim for a combination may be expressed as a means or step for performing a specified function without the recital of structure, material, or acts in support thereof, and such claim shall be construed to cover the corresponding structure, material, or acts described in the specification and equivalents thereof.

35 U.S.C. § 112(f).

When a claim term lacks the word “means,” 35 U.S.C. § 112(f) is presumed to not apply unless “the challenger demonstrates that the claim term fails to ‘recite sufficiently definite structure’ or else recites ‘function without reciting sufficient structure for performing that function.’” *Williamson v. Citrix Online, LLC*, 792 F.3d 1339, 1349 (Fed. Cir. 2015) (quoting *Watts v. XL Sys., Inc.*, 232 F.3d 877, 880 (Fed. Cir. 2000)). The standard for whether the means-plus-function limitation applies is “whether the words of the claim are understood by persons of ordinary skill in the art to have a sufficiently definite meaning as the name for structure.” *Williamson*, 792 F.3d at 1349. Defendants argue that “processor subsystem” is a nonce term that can mean anything. However, “[e]ven if a patentee elects to use a ‘generic’ claim term, such as ‘a nonce word or a verbal construct,’ properly construing that term (in view of the specification, prosecution history, *etc.*) may still provide sufficient structure such that the presumption against means-plus-function claiming remains intact.” *Apple Inc. v. Motorola, Inc.*, 757 F.3d 1286, 1299 (Fed. Cir. 2014) *overruled on other grounds by Williamson v. Citrix Online, LLC*, 792 F.3d 1339 (Fed. Cir. 2015).

### Sufficiently Definite Structure

For the purposes of § 112(f), “it is sufficient if the claim term is used in common parlance or by persons of skill in the pertinent art to designate structure, even if the term covers a broad class of structures and even if the term identifies the structures by their function.”

*Lighting World, Inc. v. Birchwood Lighting, Inc.*, 382 F.3d 1354, 1359-60 (Fed. Cir. 2004)

*overruled on other grounds by Williamson*, 792 F.3d 1339. “[T]he Federal Circuit only requires . . . that the claim recite some structure to avoid § 112(6) and has repeatedly rejected as ‘unduly restrictive’ the argument that ‘specific structure’ is necessary.” *GoDaddy.com, LLC v.*

*RPost Commc’ns Ltd.*, No. CV-14-00126-PHX-JAT, 2016 WL 212676, at \*55 (D. Ariz. Jan. 19, 2016) (citing *Lighting World*, 382 F.3d at 1359-60). As the court in *GoDaddy.com* found, “one of ordinary skill in the art would understand that ‘processor’ encompasses a microprocessor or microcontroller – structural terms.” *Id.* at \*56. Indeed, the patent specifications provide a microprocessor as an example of a processor subsystem. (‘781, 5:54.) The patent recites a sufficiently definite structure.

### Sufficient Structure for Performing a Function

However, the presumption against application of § 112(f) may also be overcome if the claim recites “function without reciting sufficient structure for performing that function.”

*Williamson*, 792 F.3d at 1349 (quoting *Watts*, 232 F.3d at 880). The patent provides for several different functions that may be generally described as receiving information from the sensors, exchanging data with the memory subsystem, and determining whether to activate a notification circuit.

If a processor provides general functions, then the term “processor” may provide sufficient structure for performing those functions. *See In re Katz Interactive Call Processing*

*Patent Litig.*, 639 F.3d 1303, 1316 (Fed. Cir. 2011) (holding that functions such as “processing,” “receiving,” and “storing” that can be achieved by any general purpose computer without special programming do not require disclosure of more structure than the general purpose processor that performs those functions). However, the claim language states that the processor subsystem “determines” whether to activate a notification circuit. This implies that the processor subsystem must compare data, in conjunction with the memory subsystem, in order to determine whether or not to activate a notification circuit, which requires additional programming of the processor. *See GoDaddy.com, LLC*, 2016 WL 212676, at \*56 (“ . . . the Court concludes that ‘associating’ two sets of data in order to ‘generate’ a third set of data is not a typical function found in a general purpose processor and requires additional programming of the processor to implement.”). Because the claim does not provide sufficient structure for performing those functions, the presumption is overcome, and § 112(f) applies.

#### Means Plus Function Construction

Because the patent calls for a processor to perform more than a general function, an algorithm is required. *See EON Corp. IP Holdings LLC v. AT&T Mobility LLC*, 785 F.3d 616, 623 (Fed. Cir. 2015) (“A microprocessor or general purpose computer lends sufficient structure only to basic functions of a microprocessor. All other computer-implemented functions require disclosure of an algorithm.”). The algorithm that transforms the general purpose processor into a special purpose processor that performs the claimed function is required. *See Aristocrat*, 521 F.3d at 1333. Plaintiff argues that the Defendants’ constructions would render several dependent claims superfluous. However, as Defendants argue, “[a] means-plus-function limitation is not made open-ended by the presence of another claim specifically claiming the disclosed structure which underlies the means clause or an equivalent of that structure.” *Laitram Corp. v.*

*Rexnord, Inc.*, 939 F.2d 1533, 1538 (Fed. Cir. 1991). Further, Plaintiff provides no alternate constructions for a means-plus-function construction.

The Court adopts the Defendants’ constructions:

“Processor” Subsystem	Claims	Construction
<p>“a processor subsystem . . . said processor subsystem determining, based upon data received from said plurality of sensors, when to activate said fuel overinjection circuit and when to activate [said upshift notification circuit [claim 1] / said downshift notification circuit [claim 7] / said upshift notification circuit and said downshift notification circuit [claim 13]]”</p>	<p>1, 7, 13</p>	<p><b>Function:</b> determining, based upon data received from said plurality of sensors, when to activate said fuel overinjection circuit and when to activate:</p> <ul style="list-style-type: none"> <li>• [said upshift notification circuit [claim 1] /</li> <li>• said downshift notification circuit [claim 7] /</li> <li>• said upshift notification circuit and said downshift notification circuit [claim 13]]</li> </ul> <p><b>Corresponding Structure:</b> a microprocessor programmed to perform the algorithm described at 11:13-13:35 and Figs. 2A-2B. Specifically, the algorithm includes:</p> <p><i>[Claims 1, 7, and 13]</i> Activating the Fuel Overinjection Notification Circuit When:</p> <ol style="list-style-type: none"> <li>1. Road speed is increasing; and</li> <li>2. Throttle position is increasing; and</li> <li>3. Manifold pressure is above a manifold pressure set point;</li> </ol> <p><i>Or</i></p> <ol style="list-style-type: none"> <li>1. Road speed is decreasing; and</li> <li>2. Throttle position is increasing; and</li> <li>3. Manifold pressure is increasing; and</li> <li>4. Engine speed is decreasing.</li> </ol> <p><i>[Claims 1 and 13]</i> Activating the Upshift Notification Circuit When:</p> <ol style="list-style-type: none"> <li>1. Road speed is increasing; and</li> <li>2. Throttle position is increasing; and</li> </ol>

“Processor” Subsystem	Claims	Construction
		<p><b>3.</b> Manifold pressure is at or below a manifold pressure set point; and</p> <p><b>4.</b> Engine speed is at or above an engine speed set point.</p> <p><i>[Claims 7 and 13] Activating the Downshift Notification Circuit When:</i></p> <p><b>1.</b> Road speed is decreasing; and</p> <p><b>2.</b> Throttle position is increasing; and</p> <p><b>3.</b> Manifold pressure is increasing; and</p> <p><b>4.</b> Engine speed is decreasing.</p>
<p>“a processor subsystem . . . said processor subsystem determining, based upon data received from said radar detector, said at least one sensor and said memory subsystem, when to activate said vehicle proximity alarm circuit, when to activate said fuel overinjection circuit and when to activate said upshift notification circuit”</p>	<p>17</p>	<p><b>Function:</b> <i>[Claim 17]</i> determining, based upon data received from said radar detector, said at least one sensor and said memory subsystem, when to activate said vehicle proximity alarm circuit, when to activate said fuel overinjection circuit, and when to activate said upshift notification circuit</p> <p><b>Corresponding Structure:</b> a microprocessor programmed to perform the algorithm described at 9:29-10:50 and 11:13-13:7 and Figs. 2A-2B. Specifically, the algorithm includes:</p> <p>Activating the Vehicle Proximity Alarm Circuit When:</p> <p><b>1.</b> The distance to the object is less than the stopping distance retrieved from the selected speed/stopping distance table; and</p> <p><b>2.</b> The vehicle brake is off; and</p> <p><b>3.</b> The vehicle speed is &gt; 35 mph.</p> <p>Activating the Fuel Overinjection Notification Circuit When:</p> <p><b>1.</b> Road speed is increasing; and</p> <p><b>2.</b> Throttle position is increasing; and</p> <p><b>3.</b> Manifold pressure is above a manifold pressure set point;</p>

“Processor” Subsystem	Claims	Construction
		<p><i>Or</i></p> <ol style="list-style-type: none"> <li>1. Road speed is decreasing; and</li> <li>2. Throttle position is increasing; and</li> <li>3. Manifold pressure is increasing; and</li> <li>4. Engine speed is decreasing.</li> </ol> <p>Activating the Upshift Notification Circuit When:</p> <ol style="list-style-type: none"> <li>1. Road speed is increasing; and</li> <li>2. Throttle position is increasing; and</li> <li>3. Manifold pressure is at or below a manifold pressure set point; and</li> <li>4. Engine speed is at or above an engine speed set point.</li> </ol>
<p>“a processor subsystem . . . said processor subsystem determining whether to activate said vehicle proximity alarm circuit based upon separation distance data received from said radar detector, vehicle speed data received from said road speed sensor and said first vehicle speed/stopping distance table stored in said memory subsystem”</p>	<p>60, 69, 76</p>	<p><b>Function:</b> determining whether to activate said vehicle proximity alarm circuit based upon separation distance data received from said radar detector, vehicle speed data received from said road speed sensor and said first vehicle speed/stopping distance table stored in said memory subsystem</p> <p><b>Corresponding Structure:</b> a microprocessor programmed to perform the algorithm described at 9:29-10:50 and Figs. 2A-2B. Specifically, the algorithm includes:</p> <p>Activating the Vehicle Proximity Alarm Circuit When:</p> <ol style="list-style-type: none"> <li>1. The distance to the object is less than the stopping distance retrieved from the selected speed/stopping distance table; and</li> <li>2. The vehicle brake is off; and</li> <li>3. The vehicle speed is &gt; 35 mph.</li> </ol>
<p>“a processor subsystem . . . said processor subsystem determines whether to activate said fuel overinjection circuit based upon at least the data received from said road speed sensor”</p>	<p>60</p>	<p><b>Function:</b> determines whether to activate said fuel overinjection notification circuit based upon at least the data received from said road speed sensor</p> <p><b>Corresponding Structure:</b> a</p>



“Processor” Subsystem	Claims	Construction
		microprocessor programmed to perform the algorithm described at 11:13-13:7 and Figs. 2A-2B. Specifically, the algorithm includes:  Activating the Fuel Overinjection Notification Circuit When: <b>1.</b> Road speed is increasing; and <b>2.</b> Throttle position is increasing; and <b>3.</b> Manifold pressure is above a manifold pressure set point; <b>Or</b> <b>1.</b> Road speed is decreasing; and <b>2.</b> Throttle position is increasing; and <b>3.</b> Manifold pressure is increasing; and <b>4.</b> Engine speed is decreasing.

*“Plurality of Sensors. . .”*

The parties dispute the proper construction of the term “plurality of sensors coupled to a vehicle having an engine, said plurality of sensors, which collectively monitor operation of said vehicle, including a road speed sensor, [(Claims 1, 13) an engine speed sensor,] a manifold pressure sensor and a throttle position sensor.” This term is located in Claims 1, 7, 13, and 28.

The following are the parties’ proposed constructions:

Velocity’s Proposed Construction	Defendants’ Proposed Construction
Two or more sensors that are coupled to and collectively monitor the operation of a vehicle with an engine, said two or more sensors are from the group of a road speed sensor, [(Claims 1, 13) an engine speed sensor,] a manifold pressure sensor and a throttle position sensor.	At least a road speed sensor, [(Claims 1, 13) an engine speed sensor,] manifold pressure sensor, and throttle position sensor coupled to a vehicle with an engine and that collectively monitor the vehicle’s operation.

The parties also dispute the related term “at least one sensor coupled to said vehicle for monitoring operation thereof, said at least one sensor including a road speed sensor, a manifold pressure sensor, a throttle position sensor and an engine speed sensor” in Claim 17.

Velocity’s Proposed Construction	Defendants’ Proposed Construction
One or more sensors that are coupled to and monitor the operation of a vehicle with an engine said one or more sensors are from the group of a road speed sensor, a throttle position sensor and an engine speed sensor.	At least a road speed sensor, a manifold pressure sensor, a throttle position sensor, and an engine speed sensor coupled to a vehicle and that collectively monitor the vehicle’s operation.

Defendants argue that both “said plurality” and “said at least one” must refer to each sensor listed. Plaintiff contends that these terms may refer to combinations of sensors within the group of sensors listed. As stated above, the words of a claim are “generally given their ordinary and customary meaning,” that is, “the meaning that the term would have to a person of ordinary skill in the art in question at the time of the invention.” *Phillips*, 415 F.3d at 1312-13.

Plaintiff argues that the doctrine of claim differentiation means that “and” should be construed as disjunctive because to construe “and” conjunctively would make several dependent claims superfluous. “To the extent that the absence of such difference in meaning and scope would make a claim superfluous, the doctrine of claim differentiation states the presumption that the difference between claims is significant.” *Tandon Corp. v. U.S. Int’l Trade Comm’n*, 831 F.2d 1017, 1023 (Fed. Cir. 1987). Defendants argue that dependent claims cannot broaden an independent claim from which they depend, citing *Enzo*. *See Enzo*, 780 F.3d at 1156 (“ . . . dependent claims cannot broaden an independent claim from which they depend.”).

However, in the patent at issue, the dependent claims do not broaden the independent claims. They do not add a limitation to the independent claim. In *Enzo*, the Federal Circuit held that a

dependent claim could not add “direct detection” to an independent claim that included only “indirect detection.” *Id.* at 1157. In the patent at issue, the dependent claims do not add sensors that were not already included in the independent claims. Interpreting “and” disjunctively is more faithful to the claim language and the specifications.

Defendants also argue that there was a prosecution disclaimer in that the language containing “and” was added during the prosecution. However, the addition of this language was not an unambiguous disclaimer. *Omega Eng., Inc. v. Raytek Corp.*, 334 F.3d 1314, 1324 (Fed. Cir. 2003) (noting Federal Circuit has “declined to apply the doctrine of prosecution disclaimer where the alleged disavowal of claim scope is ambiguous”).

The Court adopts the following construction for “plurality of sensors coupled to a vehicle having an engine, said plurality of sensors, which collectively monitor operation of said vehicle, including a road speed sensor, [(Claims 1, 13) an engine speed sensor,] a manifold pressure sensor and a throttle position sensor”: Two or more sensors that are coupled to and collectively monitor the operation of a vehicle with an engine, said two or more sensors are from the group of a road speed sensor, [(Claims 1, 13) an engine speed sensor,] a manifold pressure sensor and a throttle position sensor. The Court adopts the following construction for “at least one sensor coupled to said vehicle for monitoring operation thereof, said at least one sensor including a road speed sensor, a manifold pressure sensor, a throttle position sensor and an engine speed sensor”: One or more sensors that are coupled to and monitor the operation of a vehicle with an engine said one or more sensors are from the group of a road speed sensor, a throttle position sensor and an engine speed sensor.

*“Said at Least One Sensor”*

The parties dispute the proper construction of the term “said at least one sensor” in Claims 69 and 76. The following are the parties’ proposed constructions:

Velocity’s Proposed Construction	Defendants’ Proposed Construction
Two or more sensors from the group of a road speed sensor, an engine speed sensor, and a brake sensor.	Indefinite

Defendants argue that this term is indefinite because there is no antecedent basis for the term. Claims 69 and 76 both recite a “plurality of sensors including a road speed sensor, an engine speed sensor, and a brake sensor” and then recite that a processor subsystem is “coupled to . . . said at least one sensor.” A claim may be indefinite “if a term does not have proper antecedent basis where such basis is not otherwise present by implication or the meaning is not reasonably ascertainable.” *Halliburton Energy Servs., Inc. v. M-I LLC*, 514 F.3d 1244, 1249 (Fed. Cir. 2008) (citing *Energizer Holdings, Inc. v. Int’l Trade Comm’n*, 435 F.3d 1366, 1370-71 (Fed. Cir. 2006)). The claim must be “insolubly ambiguous.” *Id.*

Plaintiff argues that “said at least one sensor” must be read in context and that one skilled in the art would know that it referred to the plurality of sensors<sup>3</sup>. Plaintiff further states that this was a drafting error that went uncorrected. “When the meaning of the claim would reasonably be understood by persons of ordinary skill when read in light of the specification, the claim is not subject to invalidity upon departure from the protocol of ‘antecedent basis.’”

---

<sup>3</sup> This argument is supported by their expert, Mr. Nranian. *See* (Nranian Decl. ¶ 70.).

*Energizer Holdings, Inc.*, 435 F.3d at, 1370. The term “said at least one sensor,” when read in light of the specification, would reasonably be understood by persons of ordinary skill to refer to the “plurality of sensors” listed just above. The meaning is not insolubly ambiguous.

The Court adopts the following construction for “said at least one sensor”: Two or more sensors from the group of a road speed sensor, an engine speed sensor, and a brake sensor.

*“First Vehicle Speed/Stopping Distance Table”*

The parties dispute the proper construction of the term “first vehicle speed/stopping distance table” in Claims 17, 66, 69, and 76. The following are the parties’ proposed constructions:

Velocity’s Proposed Construction	Defendants’ Proposed Construction
First data structure for organizing vehicle speed and stopping distance information.	A table used to look-up the stopping distance for any given vehicle speed.

Defendants argue that the patent specifically claims a table. Plaintiff argues that a “look-up table” is a particular type of data arrangement and that the limitation should not be read into the claim. The patent description states that the speed/stopping distance table “provide[s] the relationship between the speed at which a vehicle is travelling and the distance which the vehicle will require to come to a complete stop if travelling at that speed.” (‘781 Pat., 9:11-13.) The patent also states that the speed/stopping distance table allows the processor subsystem to “look-up the stopping distance for that speed.” (*Id.* at 9:14-15.)

Plaintiff’s construction would not give meaning to the term “table.” A “claim construction that gives meaning to all the terms of the claim is preferred over one that does not do so.” *Merck & Co. v. Teva Pharm. USA, Inc.*, 395 F.3d 1364, 1372 (Fed. Cir. 2005). Further, the intrinsic evidence supports Defendants’ construction. While Plaintiff argues that a “look-up

table” is a specific type of table, Defendants’ construction does not limit the table specifically to a “look-up table.” The Court adopts the following construction for “first vehicle speed/stopping distance table”: A table used to look-up the stopping distance for any given vehicle speed.

*“Set Point”*

The parties dispute the proper construction of the terms “manifold pressure set point” in Claims 1, 7, 13, and 17 and “[RPM/engine speed] set point” in Claims 1, 13, 17, and 76. The following are the parties’ proposed constructions:

Velocity’s Proposed Construction	Defendants’ Proposed Construction
A value set for [manifold pressure/engine speed]	The threshold above which the [manifold pressure/engine rotation speed] for the vehicle should never exceed

Defendants argue that the patent specification contains a lexicographic definition for manifold pressure set point and RPM/engine speed set point. The patent description states that manifold pressure set point and RPM set point “represent thresholds above which the manifold pressure and engine rotation speed, respectively, for the vehicle should never exceed.”

(‘781 Pat., 6:66-7:4.) Plaintiff argues that this is only a description of the preferred embodiment and would render dependent claim 44 superfluous.

There is “an inherent tension . . . as to whether a statement is a clear lexicographic definition or a description of a preferred embodiment. The problem is to interpret claims ‘in view of the specification’ without unnecessarily importing limitations from the specification into the claims.” *E-Pass Techs., Inc. v. 3Com Corp.*, 343 F.3d 1364, 1369 (Fed. Cir. 2003). “[T]he presence of a dependent claim that adds a particular limitation gives rise to a presumption that the limitation in question is not present in the independent claim.” *Aspex Eyewear, Inc. v. Marchon Eyewear, Inc.*, 672 F.3d 1335, 1348 (Fed. Cir. 2012) (quoting *Phillips*, 415 F.3d at

1315). “That presumption is especially strong when the limitation in dispute is the only meaningful difference between an independent and dependent claim, and one party is urging that the limitation in the dependent claim should be read into the independent claim.”

*SunRace Roots Enter. Co. v. SRAM Corp.*, 336 F.3d 1298, 1303 (Fed. Cir. 2003). Further, the Federal Circuit has stated that “although the specification often describes very specific embodiments of the invention, we have repeatedly warned against confining the claims to those embodiments.” *Phillips*, 415 F.3d at 1323.

The description of the manifold pressure set point and RPM set point is not a clear lexicographic definition or disavowal, and Defendants have not overcome the presumption against reading the limitation into the claim. The Court adopts the following construction for “manifold pressure set point” and “[RPM/engine speed] set point”: A value set for [manifold pressure/engine speed].

*“Notification”*

The parties dispute the proper construction of the phrase “a notification” in Claims 1, 7, 13, 17, 53, 60, 69, and 76. The following are the parties’ proposed constructions:

Velocity’s Proposed Construction	Defendants’ Proposed Construction
An act or instance of notifying, making known or giving notice to the operator of the vehicle.	<p><b>Mercedes/FCA:</b> A warning notifying the operator of the vehicle.</p> <p><b>Audi:</b> An alert for notifying the driver of the vehicle of recommended corrections in vehicle operation and alerting the driver to unsafe operating conditions.</p>

Defendants essentially argue that notification should be construed as a warning or an alert. “[T]he words of a claim are generally given their ordinary and customary meaning.” *Phillips*, 415 F.3d at 1312. There is no reason why “a notification” should not be given its

ordinary and customary meaning. Warnings and alerts are types of notifications, but there is no reason to limit the term “a notification” to warnings and alerts. Further, “[w]hen different words or phrases are used in separate claims, a difference in meaning is presumed.” *Nystrom v. TREX Co.*, 424 F.3d 1136, 1143 (Fed. Cir. 2005). The claims include both notification and alarms as terms. For example, the specification provides for “a fuel overinjection *notification* circuit for issuing notification that excessive fuel is being supplied to the engine of the vehicle and a vehicle proximity alarm circuit for issuing *alarms* if the vehicle is too close to the object.” (‘781 Pat. at 4:45-49 (emphasis added).) The patent also includes the term “warning” as a type of proximity alarm circuit: “The proximity alarm circuit *may include* one or more visual and/or audible *warning* devices such as lights and/or horns. For example, the proximity alarm circuit may include a warning light and a warning horn.” (*Id.* at 7:34-38.)

The Court adopts the following construction for “a notification”: An act or instance of notifying, making known or giving notice to the operator of the vehicle.

*“Not Being Operated Fuel Efficiently”*

The parties dispute the proper construction of the phrase “not being operated fuel efficiently” in Claim 42. The following are the parties’ proposed constructions:

Velocity’s Proposed Construction	Defendants’ Proposed Construction
Term does not require construction	Indefinite

Defendants repeat their indefiniteness arguments from the discussion of “fuel overinjection notification circuit.” For the reasons discussed above, “not being operated fuel efficiently” is not indefinite. Defendants have not shown, by clear and convincing evidence, that the ‘781 Patent fails to inform, with reasonable certainty, an individual skilled in the art about the scope of the invention in light of the specification and the prosecution history. Further,



it is not a term with special meaning in the art or in this patent. Indeed, as argued by Plaintiff, Defendants’ user manuals for vehicles reference fuel efficiency. *See* (PA 186-87, 191, 193, 197, 200, 203-205, 209, 213-14, 218.) Accordingly, the term “not being operated fuel efficiently” does not require construction.

*“Excessive Engine Speed”*

Velocity and Audi dispute the proper construction of the phrase “excessive engine speed” in Claims 1, 13, 17, 23, and 40. The following are the parties’ proposed constructions:

Velocity’s Proposed Construction	Defendants’ Proposed Construction
Engine rotation speed that exceeds a threshold	<b>Audi:</b> Indefinite

Audi argues that this term is also indefinite because there is no objective boundary. As previously discussed, a “claim can be definite even where there is no precise numerical boundary so long as a person of skill in the art can determine the scope with reasonable certainty.” *GPNE Corp.*, 108 F. Supp. 3d at 874. Further, other parts of the patent make reference to manufacturers’ guidelines for engine-specific thresholds. While the patent does not point to a specific threshold, “[s]ome modicum of uncertainty . . . is the ‘price of ensuring the appropriate incentives for innovation.’” *Nautilus, Inc.*, 134 S. Ct. 2120, 2128 (quoting *Festo Corp.*, 535 U.S. at 732). Audi has not shown, by clear and convincing evidence, that the ‘781 Patent fails to inform, with reasonable certainty, an individual skilled in the art about the scope of the invention in light of the specification and the prosecution history.

The Court adopts the following construction for “excessive engine speed”: Engine rotation speed that exceeds a threshold.

*“Too Close”*

Velocity and Audi dispute the proper construction of the phrase “too close” in Claims 17, 26, 69, and 76. The following are the parties’ proposed constructions:

Velocity’s Proposed Construction	Defendants’ Proposed Construction
A distance that falls below a threshold	<b>Audi:</b> Indefinite

Audi argues that this term is also indefinite because there is no objective boundary. Again, a “claim can be definite even where there is no precise numerical boundary so long as a person of skill in the art can determine the scope with reasonable certainty.” *GPNE Corp.*, 108 F. Supp. 3d at 874. The patent describes a vehicle speed/stopping distance table in several claims. As construed above, this table contains information used to look-up the stopping distance for any given vehicle speed. Claims 17, 26, 69, and 76 reference the “first vehicle speed/stopping distance table.” Therefore, the term “too close” is determined in reference to the information stored in the “first vehicle speed/stopping distance table.” Audi has not shown, by clear and convincing evidence, that the ‘781 Patent fails to inform, with reasonable certainty, an individual skilled in the art about the scope of the invention in light of the specification and the prosecution history.

The Court adopts the following construction for “too close”: A distance that falls below a threshold stored in the first vehicle speed/stopping distance table.<sup>4</sup>

---

<sup>4</sup> This construction was not advanced by any party. “[T]he judge’s task is not to decide which of the adversaries is correct” but instead to “independently assess the claims, the specification, and if necessary the prosecution history, and the relevant extrinsic evidence, and declare the meaning of the claims.” *Exxon Chem. Patents v. Lubrizol, Corp.*, 64 F.3d 1553, 1555 (Fed. Cir. 1995); *see also MEMS Tech. Berhad v. Int’l Trade Comm’n*, 447 Fed. App’x 142, 143 (Fed. Cir. 2011) (“[T]he fact that neither party advanced the claim construction adopted by the Commission is not legal error.”).

*“Corrective”*

Velocity and Audi dispute the proper construction of the phrase “corrective” in Claims 40 and 75. The following are the parties’ proposed constructions:

Velocity’s Proposed Construction	Defendants’ Proposed Construction
Term does not require construction	<b>Audi:</b> Indefinite

Claim 40 recites: “Apparatus for optimizing operation of a vehicle according to claim 1, wherein said notification that the engine is being operated [at] an excessive speed comprises an automatic corrective action by the vehicle.” (‘781 Pat. Reexamination, 2:1-4.) Claim 75 recites: “Apparatus for optimizing operation of a vehicle according to claim 69, wherein said processor subsystem tracks the number of vehicle proximity alarms issued before corrective action eliminates a hazardous condition.” (*Id.* at 5:59:62.) Corrective action is defined in the claims as correcting excessive engine speed and vehicle proximity. The intrinsic evidence provides general guidance and examples sufficient to enable a person of ordinary skill in the art to determine the scope of the term “corrective.” *See Enzo*, 599 F.3d at 1335. Audi has not shown, by clear and convincing evidence, that the ‘781 Patent fails to inform, with reasonable certainty, an individual skilled in the art about the scope of the invention in light of the specification and the prosecution history.

“Corrective” is not a term with special meaning in the art or in this patent. Accordingly, this term does not require construction.

*“Hazardous Condition”*

Velocity and Audi dispute the proper construction of the phrase “hazardous condition” in Claim 75<sup>5</sup>. The following are the parties’ proposed constructions:

Velocity’s Proposed Construction	Defendants’ Proposed Construction
A condition that is risky or dangerous	<b>Audi:</b> Indefinite

Claim 75 recites: “Apparatus for optimizing operation of a vehicle according to claim 69, wherein said processor subsystem tracks the number of vehicle proximity alarms issued before a hazardous condition is corrected.” Audi argues that the term “hazardous condition” is indefinite. In the specification, hazardous condition is referred to in the context of the “vehicle proximity alarm circuit.” The intrinsic evidence provides general guidance and examples sufficient to enable a person of ordinary skill in the art to determine the scope of the term “hazardous condition.” *See Enzo Biochem, Inc.*, 599 F.3d at 1335. Audi has not shown, by clear and convincing evidence, that the ‘781 patent fails to inform, with reasonable certainty, an individual skilled in the art about the scope of the invention in light of the specification and the prosecution history. However, Audi is correct that Plaintiff’s construction is overbroad and encompasses more than the intrinsic evidence supports.

The Court adopts the following construction for “hazardous condition”: Condition where the vehicle’s distance falls below the safe stopping distance stored in the first vehicle speed/stopping distance table.

---

<sup>5</sup> The claim construction briefs and the Joint Appendix state that the term “hazardous condition” is in Claim 42. However, Claim 42 does not contain the term “hazardous condition.”

## CONCLUSION

Therefore, the disputed terms are constructed as follows:

Term	Construction
“fuel overinjection notification circuit . . . , said fuel overinjection notification circuit issuing a notification that excessive fuel is being supplied to said engine of said vehicle” (Claims 1, 7, 13, 17, 28, 60, 69, 76)	A circuit that notifies a driver that more fuel is being supplied to the engine than is necessary.
“insufficient engine speed” (Claims 7, 13)	Engine rotation speed falls below a threshold.
“a processor subsystem . . . said processor subsystem determining . . .” (Claims 1, 7, 13, 17, 60, 69, 76)	Claim is governed by § 112(f). See Appendix 1.
“plurality of sensors coupled to a vehicle having an engine, said plurality of sensors, which collectively monitor operation of said vehicle, including a road speed sensor, [(Claims 1, 13) an engine speed sensor,] a manifold pressure sensor and a throttle position sensor” (Claims 1, 7, 13, 28)	Two or more sensors that are coupled to and collectively monitor the operation of a vehicle with an engine, said two or more sensors are from the group of a road speed sensor, [(Claims 1, 13) an engine speed sensor,] a manifold pressure sensor and a throttle position sensor.
“at least one sensor coupled to said vehicle for monitoring operation thereof, said at least one sensor including a road speed sensor, a manifold pressure sensor, a throttle position sensor and an engine speed sensor” (Claim 17)	One or more sensors that are coupled to and monitor the operation of a vehicle with an engine said one or more sensors are from the group of a road speed sensor, a throttle position sensor and an engine speed sensor.
“said at least one sensor” (Claims 69, 76)	Two or more sensors from the group of a road speed sensor, an engine speed sensor, and a brake sensor.
“first vehicle speed/stopping distance table” (Claims 17, 66, 69, 76)	A table used to look-up the stopping distance for any given vehicle speed.
“manifold pressure set point” (Claims 1, 7, 13, 17)	A value set for [manifold pressure/engine speed].
“[RPM/engine speed] set point” (Claims 1, 13, 17, 76)	
“a notification” (Claims 1, 7, 13, 17, 53,	An act or instance of notifying, making

Term	Construction
60, 69, 76)	known or giving notice to the operator of the vehicle.
“not being operated fuel efficiently” (Claim 42)	Term does not require construction.
“excessive engine speed” (Claims 1, 13, 17, 23, 40)	Engine rotation speed that exceeds a threshold.
“too close” (Claims 17, 26, 69, 76)	A distance that falls below a threshold stored in the first vehicle speed/stopping distance table.
“corrective” (Claims 40, 75)	This term does not require construction.
“hazardous condition” (Claim 75)	Condition where the vehicle’s distance falls below the safe stopping distance stored in the first vehicle speed/stopping distance table.

Date: September 21, 2016

  
 JOHN W. DARRAH  
 United States District Court Judge

## Appendix 1

“Processor” Subsystem	Claims	Construction
<p>“a processor subsystem . . . said processor subsystem determining, based upon data received from said plurality of sensors, when to activate said fuel overinjection circuit and when to activate [said upshift notification circuit [claim 1] / said downshift notification circuit [claim 7] / said upshift notification circuit and said downshift notification circuit [claim 13]]”</p>	<p>1, 7, 13</p>	<p><b>Function:</b> determining, based upon data received from said plurality of sensors, when to activate said fuel overinjection circuit and when to activate:</p> <ul style="list-style-type: none"> <li>• [said upshift notification circuit [claim 1] /</li> <li>• said downshift notification circuit [claim 7] /</li> <li>• said upshift notification circuit and said downshift notification circuit [claim 13]]</li> </ul> <p><b>Corresponding Structure:</b> a microprocessor programmed to perform the algorithm described at 11:13-13:35 and Figs. 2A-2B. Specifically, the algorithm includes:</p> <p><i>[Claims 1, 7, and 13]</i> Activating the Fuel Over-Injection Notification Circuit When:</p> <ol style="list-style-type: none"> <li>1. Road speed is increasing; and</li> <li>2. Throttle position is increasing; and</li> <li>3. Manifold pressure is above a manifold pressure set point;</li> </ol> <p><i>Or</i></p> <ol style="list-style-type: none"> <li>1. Road speed is decreasing; and</li> <li>2. Throttle position is increasing; and</li> <li>3. Manifold pressure is increasing; and</li> <li>4. Engine speed is decreasing.</li> </ol> <p><i>[Claims 1 and 13]</i> Activating the Upshift Notification Circuit When:</p> <ol style="list-style-type: none"> <li>1. Road speed is increasing; and</li> <li>2. Throttle position is increasing; and</li> <li>3. Manifold pressure is at or below a manifold pressure set point; and</li> <li>4. Engine speed is at or above an engine speed set</li> </ol>

“Processor” Subsystem	Claims	Construction
		<p>point.</p> <p><b>[Claims 7 and 13]</b> Activating the Downshift Notification Circuit When:</p> <ol style="list-style-type: none"> <li>1. Road speed is decreasing; and</li> <li>2. Throttle position is increasing; and</li> <li>3. Manifold pressure is increasing; and</li> <li>4. Engine speed is decreasing.</li> </ol>
<p>“a processor subsystem . . . said processor subsystem determining, based upon data received from said radar detector, said at least one sensor and said memory subsystem, when to activate said vehicle proximity alarm circuit, when to activate said fuel overinjection circuit and when to activate said upshift notification circuit”</p>	<p>17</p>	<p><b>Function:</b> <i>[Claim 17]</i> determining, based upon data received from said radar detector, said at least one sensor and said memory subsystem, when to activate said vehicle proximity alarm circuit, when to activate said fuel overinjection circuit, and when to activate said upshift notification circuit</p> <p><b>Corresponding Structure:</b> a microprocessor programmed to perform the algorithm described at 9:29-10:50 and 11:13-13:7 and Figs. 2A-2B. Specifically, the algorithm includes:</p> <p>Activating the Vehicle Proximity Alarm Circuit When:</p> <ol style="list-style-type: none"> <li>1. The distance to the object is less than the stopping distance retrieved from the selected speed/stopping distance table; and</li> <li>2. The vehicle brake is off; and</li> <li>3. The vehicle speed is &gt; 35 mph.</li> </ol> <p>Activating the Fuel Over-Injection Notification Circuit When:</p> <ol style="list-style-type: none"> <li>1. Road speed is increasing; and</li> <li>2. Throttle position is increasing; and</li> <li>3. Manifold pressure is above a manifold pressure set point;</li> </ol> <p><b>Or</b></p> <ol style="list-style-type: none"> <li>1. Road speed is decreasing; and</li> <li>2. Throttle position is increasing; and</li> <li>3. Manifold pressure is increasing; and</li> </ol>



“Processor” Subsystem	Claims	Construction
		<p><b>4.</b> Engine speed is decreasing.</p> <p>Activating the Upshift Notification Circuit When:</p> <ol style="list-style-type: none"> <li><b>1.</b> Road speed is increasing; and</li> <li><b>2.</b> Throttle position is increasing; and</li> <li><b>3.</b> Manifold pressure is at or below a manifold pressure set point; and</li> <li><b>4.</b> Engine speed is at or above an engine speed set point.</li> </ol>
<p>“a processor subsystem . . . said processor subsystem determining whether to activate said vehicle proximity alarm circuit based upon separation distance data received from said radar detector, vehicle speed data received from said road speed sensor and said first vehicle speed/stopping distance table stored in said memory subsystem”</p>	<p>60, 69, 76</p>	<p><b>Function:</b> determining whether to activate said vehicle proximity alarm circuit based upon separation distance data received from said radar detector, vehicle speed data received from said road speed sensor and said first vehicle speed/stopping distance table stored in said memory subsystem.</p> <p><b>Corresponding Structure:</b> a microprocessor programmed to perform the algorithm described at: 9:29-10:50 and Figs. 2A-2B. Specifically, the algorithm includes:</p> <p>Activating the Vehicle Proximity Alarm Circuit When:</p> <ol style="list-style-type: none"> <li><b>1.</b> The distance to the object is less than the stopping distance retrieved from the selected speed/stopping distance table; and</li> <li><b>2.</b> The vehicle brake is off; and</li> <li><b>3.</b> The vehicle speed is &gt; 35 mph.</li> </ol>
<p>“a processor subsystem . . . said processor subsystem determines whether to activate said fuel overinjection circuit based upon at least the data received from said road speed sensor”</p>	<p>60</p>	<p><b>Function:</b> determines whether to activate said fuel overinjection notification circuit based upon at least the data received from said road speed sensor</p> <p><b>Corresponding Structure:</b> a microprocessor programmed to perform the algorithm described at: 11: 13-13:7 and Figs. 2A-2B. Specifically, the algorithm includes:</p>

“Processor” Subsystem	Claims	Construction
		<p>Activating the Fuel Over-Injection Notification Circuit When:</p> <ol style="list-style-type: none"> <li>1. Road speed is increasing; and</li> <li>2. Throttle position is increasing; and</li> <li>3. Manifold pressure is above a manifold pressure set point;</li> </ol> <p><i>Or</i></p> <ol style="list-style-type: none"> <li>1. Road speed is decreasing; and</li> <li>2. Throttle position is increasing; and</li> <li>3. Manifold pressure is increasing; and</li> <li>4. Engine speed is decreasing.</li> </ol>