

**IN THE UNITED STATES DISTRICT COURT
FOR THE NORTHERN DISTRICT OF ILLINOIS
EASTERN DIVISION**

TACTICAL MEDICAL SOLUTIONS, INC.,)	
)	
Plaintiff,)	
)	No. 14 C 06035
v.)	
)	Judge John J. Tharp, Jr.
DR. RONALD KARL and EMI EMERGENCY MEDICAL INTERNATIONAL a/k/a EMERGENCY MEDICAL INSTRUMENTS,)	
)	
)	
)	
Defendants.)	

MEMORANDUM OPINION AND ORDER

Plaintiff Tactical Medical Solutions, Inc. (“TMS”), a business that designs and sells emergency medical products, asserts an array of claims against defendants Dr. Ronald Karl and his sole proprietorship, Emergency Medical International a/k/a Emergency Medical Instruments (“EMI”). TMS alleges that EMI infringed on TMS’s design and utility patents by selling a “knockoff” version of TMS’s SOF tourniquet, and that EMI falsely advertised the knockoff by using images of the SOF tourniquet on its website and in its product catalogs. EMI, in turn, asserts counterclaims alleging that TMS infringed on EMI’s TACMED trademark, and that TMS interfered with EMI’s business relationships with its distributors by sending them threatening cease-and-desist letters. TMS moves for summary judgment on the bulk of the claims and counterclaims remaining in this case and certain of EMI’s affirmative defenses. A genuine dispute of material fact exists as to the validity of TMS’s patents, but only on one of the grounds EMI asserts in its affirmative defense as to the design patent (functionality under 35 U.S.C. § 171(a)) and one as to the utility patents (obviousness under 35 U.S.C. § 103). EMI has offered no support

for two of its other affirmative defenses, but TMS has not established that no material fact dispute exists as to the other claims and counterclaims. TMS's motion for partial summary judgment, ECF No. 135, is therefore granted in part and denied in part.

I. Background

Defendant Karl has done business through EMI¹ and has sold emergency medical products under the TACMED mark since at least as early as 2002. Plaintiff TMS was co-founded in 2003 by Ross Johnson, who continues to serve as its president and CEO. TMS began selling similar emergency medical products under the TACMED mark around 2008. A few years later, EMI began selling its Tactical Application Tourniquet (the "T.A.T. tourniquet"), which TMS alleges is an inferior knockoff version of TMS's SOF tourniquet and infringes on TMS's design and utility patents. Shortly after filing this suit, but before serving the complaint on EMI, TMS sent letters to EMI's distributors informing them that TMS had filed a lawsuit alleging intellectual property violations against EMI and another distributor, and demanding that the distributors stop selling EMI's TACMED products and the T.A.T. tourniquet. TMS now moves for partial summary judgment regarding the validity and infringement of all three of its patents at issue in this case (Counts I-III; Counterclaims VIII, X, and XII²; and First and Second Affirmative Defenses); its

¹ Throughout the remainder of this opinion, the Court uses "EMI" to refer collectively to EMI and Karl. As discussed in the Court's prior ruling denying TMS's motion to dismiss various EMI counterclaims on standing grounds, the evidence of record establishes, if barely, that EMI is an unincorporated sole proprietorship owned and operated by Karl. *See* Order dated Sept. 26, 2017 at 2-5, ECF No. 125.

² TMS's brief appears to contain a typo requesting summary judgment on Counterclaim IX (seeking declaratory judgment of invalidity of '064 utility patent) instead of Counterclaim XII (seeking declaratory judgment of non-infringement of '620 utility patent). *See* Mem. 22, ECF No. 141. Counterclaim IX has already been dismissed. *See* Order dated Sept. 21, 2015, ECF No. 62 (granting motion to dismiss invalidity counterclaims). No amended counterclaims were filed.

false representation claim (Counts VIII, X, and XI³); EMI's trademark infringement counterclaims (Counterclaims I–IV and VII); and EMI's tortious interference counterclaims (Counterclaims V and VI). TMS also moves for summary judgment as to EMI's Third and Eleventh Affirmative Defenses asserting, respectively, that TMS is estopped from making certain arguments and that TMS's claims are barred by license. EMI does not oppose TMS's motion for summary judgment on EMI's Eleventh Affirmative Defense, *see* Resp. 2 n.1, ECF No. 143, and EMI has not pointed to evidence or made argument in support of its Third Affirmative Defense.⁴

A. '642 Design Patent

In 2011, TMS obtained United States Design Patent No. D649,642 (“the ‘642 design patent”) for the shape of the SOF tourniquet handle's beveled ends, as depicted by the unbroken lines in figures one through five below.

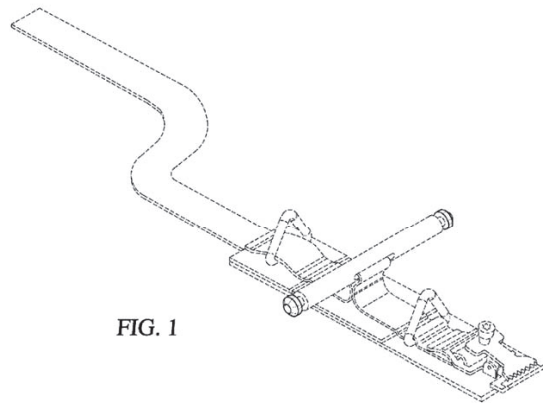

FIG. 1

³ Although TMS did not reference Counts X and XI (both alleging unfair competition based on EMI's use of the tourniquet photo) in its motion for summary judgment, TMS requests summary judgment on those counts in its memorandum of law in support of its motion. *See* Mem. 20–21, ECF No. 141. The same is true as to EMI's Third Affirmative Defense. *See id.* at 13–14.

⁴ A statement can be found in paragraph 33 of EMI's statement of facts, ECF No. 144, and paragraph 41 of Karl's declaration, ECF No. 145, that could be read as support for the portions of EMI's Third Affirmative Defense relating to its utility patents, but the Court declines to draw that connection in the absence of EMI having done so.



FIG. 2



FIG. 3



FIG. 4



FIG. 5

TMS alleges in Count III of its complaint that EMI's T.A.T. tourniquet infringed on the '642 design patent. EMI asserts non-infringement⁵ and invalidity of the '642 design patent in its First and Second Affirmative Defenses, respectively, and seeks a declaratory judgment through its Counterclaim X that it has not infringed on the '642 design patent. The T.A.T. tourniquet is depicted directly below, and the T.A.T. tourniquet handle removed from its base is depicted in the second image below.

⁵ Although "non-infringement" is routinely treated as an affirmative defense to an infringement claim, this practice appears to ignore the distinction between defenses, which do not need to be affirmatively pleaded, and affirmative defenses, which do. *See* Fed. R. Civ. P. 8(c). "[G]enerally, any defenses that 'admit the allegations of the complaint but suggest some other reason why there is no right of recovery [or] concern allegations outside of the plaintiff's prima facie case that the defendant therefore cannot raise by simple denial in the answer' are considered affirmative defenses." *Shell Oil Co. v. United States*, 896 F.3d 1299, 1315 (Fed. Cir. 2018) (citing 5 WRIGHT & MILLER, FED. PRAC. & PROC. § 1271). EMI's "non-infringement" affirmative defenses are, in substance, no different than its counterclaims for declarations of non-infringement of the three patents at issue and is therefore stricken.



EMI does not dispute that its “T.A.T. tourniquet handle has relatively identically sized, spaced, and positioned opposed pyramidal/conical tapering endcaps corresponding to the design claimed in the ‘642 patent.” EMI’s LR 56.1(b) Resp. to TMS’s LR 56.1(a) Statement of Material Facts (“DSOF”) ¶ 22 Resp., ECF No. 144. EMI instead contends that TMS’s ‘642 design patent is invalid because the truncated cone-shaped design of the handle ends is primarily functional rather than ornamental, *see* 35 U.S.C. § 171(a), and because the design was anticipated by prior art, *see* 35 U.S.C. § 102.

1. Functionality

As to the functionality grounds for invalidity pursuant to 35 U.S.C. 171(a), EMI asserts that the beveled ends of the SOF tourniquet are primarily functional because they “allow for easy

insertion of the handle ends in the locking rings to lock the handle in place when the tourniquet has been deployed.” DSOF ¶ 35; Karl Decl. ¶ 44, ECF No. 145. Indeed, two of TMS’s utility patents for the SOF tourniquet describe the functionality of the beveled handle ends. For example, TMS’s U.S. Patent No. 7,776,064 (the ‘064 patent) states that “Handle G is beveled and notched on the surface area at each end of handle G *to facilitate the securing of handle G into the locking rings,*” ECF No. 1-1 at col. 3:34-36 (emphasis added), and TMS’s U.S. Patent No. 8,303,620 patent (the ‘620 patent) identically states that “Handle G includes bevels and notches mm on the surface area at each end of handle G *to facilitate the securing of handle G into the locking rings,*” ECF No. 1-3 at col. 3:49-52 (emphasis added).⁶ TMS co-founder and CEO Ross Johnson himself said that, at the time the patent application was filed, he believed the truncated cones at the ends of the handle “would make [the tourniquet] easier to use.” DSOF ¶ 37; Patras Decl., Ex. 10, Johnson Dep. at 97:14–98:11 and 173:12–177:2, ECF No. 146-10. Patents issued for other products have also generally described the utility of beveled ends to facilitate insertion. For example, U.S. Patent No. 4,995,591, which describes fence slats designed to be inserted into a channel, states that the “purpose of beveling the end is to facilitate insertion of the slat perpendicularly into the channel,” Karl Decl., Ex. 3 at col. 2:7, ECF No. 145-3, and U.S. Patent No. 5,979,276 states that special tools used to trim the inner surface of a hose end typically have “a beveled end for easy insertion into the hose end,” Karl Decl., Ex. 4 at col. 2:42, ECF No. 145-4.

TMS contends that it has not advertised any functional aspects of the handle ends, that Johnson eventually realized that the shape of the handle-ends did not make the tourniquet easier

⁶ TMS asserts, without explanation, that neither of these patents describe any function for the beveled handle ends. *See* TMS’s LR 56.1 Statement of Material Facts to Which There Is No Genuine Dispute (“PSOF”) ¶¶ 31–32; Johnson Decl. ¶ 30, ECF No. 137.

to use, and that other tourniquets have similar handles but different handle-end designs. EMI responds that none of the other handle end designs TMS cites are to be used with the locking rings that were disclosed in TMS's patents-in-suit.

2. Prior Art

EMI also argues that the '642 design patent is invalid pursuant to 35 U.S.C. § 102 because it was anticipated by prior art: U.S. Patent No. 1,360,946 titled "Spark Plug" and U.S. Patent No. 1,855,482 titled "Knob for Drawers or the Like." EMI argues that "[e]ach of these two patents have an identical or at least substantially similar design to the ends of the handle of the tourniquet claimed in the []'642 patent." DSOF ¶ 39; Karl Decl. ¶ 49. Representative figures of the spark plug (left) and drawer knob (right) are reproduced below.

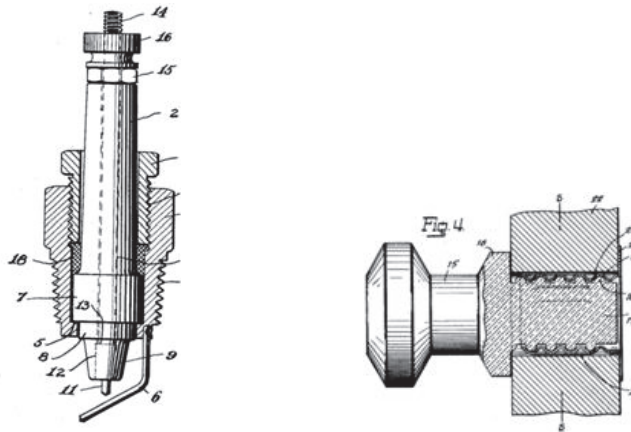

B. '064 and '620 Utility Patents

TMS also owns U.S. Patent Nos. 7,776,064 and 8,303,620 ("the '064 and '620 utility patents") for a tourniquet article. TMS alleges in Counts I and II of its complaint that EMI infringed those patents. EMI asserts non-infringement and invalidity of the '064 and '620 utility patents in its First and Second Affirmative Defenses and seeks declaratory judgment through its Counterclaims VIII and XII that it did not infringe on those patents. EMI argues that the '064 and '620 utility patents are invalid because they were anticipated pursuant to 35 U.S.C. § 102 or

obvious pursuant to 35 U.S.C. § 103 based on prior art. It also asserts that even if the patents are valid, its T.A.T. tourniquet does not infringe upon the “substantially rigid base” claim limitation of those patents.

1. Prior Art

EMI contends that the ‘064 and ‘620 utility patents are invalid because they were anticipated pursuant to 35 U.S.C. § 102 or obvious pursuant to 35 U.S.C. § 103 based on prior art. The prior art references EMI cites are both for tourniquets: One is the “Norman W. Brothers” tourniquet, Karl Decl., Ex. 1, ECF No. 145-1, and the other is the “McMillan” tourniquet, Karl Decl., Ex. 2, ECF No. 145-2. EMI asserts that “claims 1, 14, 15, and 17 of the ‘064 patent are anticipated by Brothers under 35 U.S.C. § 102” and that “[a]ll of the asserted claims (1-5, 7-12 and 14-19 of the ‘064 patent and 1-4, 6-8, 10-11 and 13 of the ‘620 patent) are obvious over Brothers alone or in combination with U.S. Patent No. 6,899,720 to McMillan issued May 31, 2005.” DSOF ¶ 34; Karl Decl. ¶ 43; Resp. 30, ECF No. 143. Karl’s declaration includes claim charts explaining why Brothers, McMillan, or some combination of those prior art references renders the claims anticipated or obvious. *See* Karl Decl., “The ‘064 Patent” and “The ‘620 Patent” charts following ¶ 43 at 9–18, ECF No. 145 (stating that Brothers discloses much of what is described in the ‘064 and ‘620 patent claims and stating, *e.g.*, as to claim 9 of the ‘064 patent that “McMillan discloses a tourniquet 10 with a handle lock (24 or 28) attached to a base 12 and positioned to receive an end of a handle 20. It would have been obvious to one of ordinary skill in the art at the time of the alleged invention to modify Brothers as taught by McMillan in order to secure the handle to the base.”).

2. Substantially Rigid Base

EMI also contends that even if the '064 and '620 utility patents are valid, EMI did not infringe on them because its T.A.T. tourniquet did not have a “substantially rigid base” as that element of the relevant patent claims has been construed by this Court. This Court previously construed “substantially rigid base” as “a base that provides sufficient rigidity to avoid binding and crushing while being flexible enough for use on a limb and facilitating storage and carriage.” Mem. Op. and Order dated Sept. 26, 2017 at 14, ECF No. 126. In support of TMS’s infringement claim, TMS president and CEO Ross Johnson testified that “the base of the T.A.T. tourniquet is flexible enough to apply to a limb but is rigid enough that it does not bind and crush when the handle is twisted,” Johnson Decl. ¶ 58, ECF No. 137, and TMS Vice President Richard Hester testified that “when the T.A.T. tourniquet is properly applied and the handle is twisted, the base does not bind the skin and generally maintains its form, that is, it is not crushed.” Hester Decl. ¶ 13, ECF No. 139. TMS also submitted a video demonstration of Hester applying the T.A.T. tourniquet to his own arm. Hester Decl. ¶¶ 12–13, Ex. 1/A, ECF No. 139.

EMI, however, contends that the base of its T.A.T. tourniquet is more flexible than the base of the Brothers prior art reference and that it is “certain” that the Brothers prior art reference base is more flexible than “substantially rigid.” DSOF ¶ 29; Karl Decl. ¶ 35; Resp. 29, ECF No. 143. The base of the Brothers tourniquet is described in its patent as “preferably formed of relatively thick leather and of such stiffness as to eliminate free bending.” DSOF ¶ 32; Karl Decl. ¶ 36, Ex. 1, Norman W. Brothers Tourniquet No. 2,387,428 at col. 2:11-12, ECF No. 145-1. Karl asserts that “what TMS contends was the ‘base’ of the T.A.T. tourniquet is more flexible than a strap of relatively thick leather of such stiffness as to eliminate free bending. For example, I can readily bend what TMS contends was the ‘base’ of the T.A.T. tourniquet 180° with minimal effort.” Karl

Decl. ¶ 36. EMI contends, therefore, that the T.A.T. tourniquet base is more flexible than even the Brothers base and hence does not have a “substantially rigid base” as would be required to infringe on the ‘064 and ‘620 utility patents.

C. EMI’s Use of Tourniquet Image

TMS contends that EMI used an image of the SOF tourniquet on its website and in its product catalogs to market the T.A.T. tourniquet. TMS asserts in counts VIII, X, and XI that the use of the images amounts to false advertising and unfair competition. The accused website image is shown in the screenshot of EMI’s website below.



In addition to the website image, TMS alleges that EMI used images of the SOF tourniquet to advertise the T.A.T. tourniquet in its product catalog. But TMS has not alleged that EMI used any image of the SOF tourniquet that depicts a greater level of detail than that which can be seen in the website screenshot above.

TMS alleges that the T.A.T. tourniquet is inferior to the SOF tourniquet in several ways, including that it uses lower-grade stitching, is covered in a coating that chips more easily, has a cap screw that rusts more easily, and lacks pin covers. But TMS has not argued that EMI misrepresented any of these alleged inferiorities by using images of the SOF tourniquet in its promotional materials. EMI argues that it innocently used the tourniquet photograph from its supplier and if, as TMS alleges, the T.A.T. tourniquet is nearly identical to the SOF tourniquet, then EMI could not have made any false representations simply by showing an image of a product that, visually at least, is virtually indistinguishable from its own.

D. TACMED Trademark

This Court previously denied EMI's motion for summary judgment on the parties' respective TACMED trademark infringement and related state law claims. *See* Order dated Sept. 26, 2017 at 5–10, ECF No. 125. The essential facts relevant to this issue are largely unchanged from when the Court previously discussed them, and familiarity with those facts is assumed. *See id.* at 5–7 (discussing facts relevant to TACMED counterclaims). In ruling on that motion, this Court noted that “the facts that bear on this issue are in substantial dispute.” *Id.* at 8; *see also id.* at 7 (“[T]here is a material fact dispute as to whether the TACMED mark is valid.”); *id.* at 10 (“[T]here is a material dispute of fact as to whether the TACMED mark is protectable.”).

E. Cease and Desist Letters

EMI asserts in Counterclaims V and VI that TMS tortiously interfered with EMI's reasonable business expectancies and contracts with its distributors by sending them threatening

cease-and-desist letters. About thirteen months before TMS sent the cease-and-desist letters, TMS president and CEO Ross Johnson wrote in an email that if he “can get some more info on who EMI is [he] might be able to make an example out of them.” DSOF ¶ 22; Defs’ Prior Statement of Facts, Ex. 34, ECF No. 110-34. And about four months before TMS sent the letters, Johnson wrote in another email that EMI “will hopefully be out of business in a few months.” DSOF ¶ 23; Defs.’ Prior Statement of Facts, Ex. 35, ECF No. 110-35. Less than a month before serving the complaint on the defendants, TMS sent cease-and-desist letters to at least seven companies that TMS believed were offering to sell the T.A.T. tourniquet or other EMI products bearing the TACMED mark. The letters informed those companies that TMS had filed an infringement suit against EMI and requested, among other things, that they “cease all sales and marketing of the T.a.t. [sic] tourniquet” and “cease all sales and marketing of EMI products under the TACMED mark” within 21 days. PSOF ¶ 56. TMS enclosed with the letters a copy of its complaint against EMI and its distributor, CopQuest.⁷ EMI had sold its products to many of the companies that received the cease-and-desist letters for several years, and in some cases, decades.

The parties agree that EMI did not have distribution agreements with its distributors, and that EMI’s customers had no forward-looking obligations to purchase EMI products. But EMI asserts that it had contracts with its customers for each individual order. EMI sent price lists to its distributors, received purchase orders from them, and issued invoices and received payment for products it sold to its distributors. TMS contends that it was aware of the nature of EMI’s business relationships with the distributors to whom TMS sent the cease-and-desist letters only to the extent that those distributors were selling the allegedly infringing T.A.T. tourniquet or other EMI

⁷ All claims against CopQuest (set forth in Counts XII through XVI) were later dismissed. *See* Stipulation of Dismissal with Prejudice Pursuant to Fed. R. Civ. P. 41(a)(1)(A)(ii), ECF No. 35.

products under the TACMED mark. TMS insists that it sent the cease-and-desist letters in good faith, intending to protect its intellectual property rights. After receiving TMS's cease-and-desist letter, several EMI distributors returned products previously delivered, did not purchase additional EMI products, stopped purchasing EMI's TACMED products, or stopped purchasing EMI products altogether. Some distributors identified the TMS case-and-desist letter as the basis for their changed business relationship with EMI.

II. Discussion

A. Standard of Review

Summary judgment is appropriate “if the movant shows that there is no genuine dispute as to any material fact and the movant is entitled to judgment as a matter of law.” *EEOC v. CVS Pharmacy, Inc.*, 809 F.3d 335, 339 (7th Cir. 2015) (quoting Fed. R. Civ. P. 56(a)). A genuine dispute as to a material fact exists “if the evidence is such that a reasonable jury could return a verdict for the nonmoving party.” *Kvapil v. Chippewa Cnty.*, 752 F.3d 708, 712 (7th Cir. 2014). When considering a motion for summary judgment, the Court construes the facts and makes all reasonable inferences in favor of the non-moving party. *Jajeh v. Cnty. of Cook*, 678 F.3d 560, 566 (7th Cir. 2012). “[D]istrict courts presiding over summary judgment proceedings may not weigh conflicting evidence . . . or make credibility determinations.” *Omnicare, Inc. v. UnitedHealth Grp., Inc.*, 629 F.3d 697, 704 (7th Cir. 2011) (internal quotation marks and citation omitted). Rather, the Court's role is “to determine whether there is a genuine issue for trial.” *Tolan v. Cotton*, 134 S. Ct. 1861, 1866 (2014).

Design and utility patents are presumptively valid. 35 U.S.C. § 282; *Ethicon Endo-Surgery, Inc. v. Covidien, Inc.*, 796 F.3d 1312, 1328 (Fed. Cir. 2015). A challenger of the validity of a design or utility patent must show that the patent is invalid by clear and convincing evidence. *Microsoft v. i4i Ltd. Partnership*, 564 U.S. 91, 95 (2011). And, of course, “if a patent is shown to

be invalid, there is no patent to be infringed.” *Commil USA, LLC v. Cisco Systems, Inc.*, 135 S.Ct. 1920, 1923 (2015).

B. Validity of ‘642 Design Patent

EMI asserts in its Second Affirmative Defense that “[e]ach claim of the ‘064, ‘642 and ‘620 patents is invalid because it fails to satisfy the conditions for patentability specified in 35 U.S.C. § 100 et seq., including §§ 101, 102, 103, 112 and 171.” Answer at 35, ECF No. 17. Material issues of fact exist as to whether the ‘642 design patent is invalid under 35 U.S.C. § 171(a) as embodying a primarily functional rather than ornamental design. The only other of these theories that EMI invokes in support of its invalidity affirmative defense as to the ‘642 design patent is § 102 (anticipation), but EMI has not shown that a reasonable jury could find that the ‘642 design patent was anticipated by the prior art cited.

1. Functionality

Design patents may be obtained for “any new, original and ornamental design for an article of manufacture.” 35 U.S.C. § 171(a). A design patent is invalid if its design is dictated by the function of its article. *Ethicon*, 796 F.3d at 1329. Courts consider several factors when determining whether the design is dictated by function, including “whether the protected design represents the best design; whether alternative designs would adversely affect the utility of the specified article; whether there are concomitant utility patents; whether the advertising touts particular features of the design as having specific utility; and whether there are any elements in the design or an overall appearance clearly not dictated by function.” *Id.* at 1330. The existence of alternative designs is an important but not dispositive factor. *Id.* at 1329–30 (“[W]hen there are several ways to achieve the function of an article of manufacture, the design of the article is more likely to serve a primarily ornamental purpose.” (citation omitted)). “Whether a patented design is functional or ornamental is a question of fact.” *PHG Techs., LLC v. St. John Cos.*, 469 F.3d 1361, 1365 (Fed. Cir. 2006).

Here, there is substantial evidence that the beveled design of the tourniquet handle serves a functional purpose, namely, facilitating insertion of the handle end into the locking device. TMS President and CEO Ross Johnson himself testified that he believed that having truncated cones at the ends of the handle would make the tourniquet “easier to use.” DSOF ¶ 37. Although Johnson now believes that the shape of the handle end caps does not make inserting the handle into the locking rings any easier, the question is whether the design was *dictated* by function, not by whether it was as effective as it was initially expected to be for that function after it was designed. Indeed, TMS’s own utility patents describe the intended functionality of the beveled ends. *See, e.g.*, U.S. Patent No. 7,776,064 at 3:34-36, ECF No. 1-1 (“Handle G is beveled and notched on the surface area at each end of handle G to facilitate the securing of handle G into the locking rings.”); U.S. Patent No. 8,303,620 at col. 3:49-52, ECF No. 1-3 (“Handle G includes bevels and notches mm on the surface area at each end of handle G to facilitate the securing of handle G into the locking rings.”). Patents for other products have recognized that beveled ends may have a functional purpose of facilitating insertion, as well. *See, e.g.*, U.S. Patent No. 4,995,591, Karl Decl., Ex. 3 at col. 2:7, ECF No. 145-3 (The “purpose of beveling the end is to facilitate insertion”); U.S. Patent No. 5,979,276, Karl Decl., Ex. 4 at col. 2:42, ECF No. 145-4 (stating that specialized hose-trimming tools typically have a “beveled end for easy insertion”).

But there is also evidence that supports the view that beveling the handle ends is not the only way to facilitate the function of inserting the handle into the locking device. TMS cites examples of tourniquets with similar handles to the SOF tourniquet but different handle end designs, such as the Combat Application Tourniquet, the Military Emergency Tourniquet, and the NATO tourniquet. A jury would not be required to credit those alternative designs, however, because it is not clear those alternative designs would work as well with the triangular locking

rings into which the beveled ends of the ‘642 design patent are intended to be inserted. *Cf. Best Lock Corp. v. Ilco Unican Corp.*, 94 F.3d 1563 (Fed. Cir. 1996) (affirming finding of invalidity on functionality grounds where key blade was designed to be inserted into keyway even though alternative key blade designs could mate with other keyways); *Static Control Components, Inc. v. Lexmark Int’l, Inc.*, 487 F. Supp. 2d 830, 841–42 (E.D. Ky. 2007), *aff’d*, 697 F.3d 387 (6th Cir. 2012) (invalidating on summary judgment two printer cartridge design patents because their designs were primarily functional as they were made to fit the printers with which they were used). Neither party has adduced evidence as to the relative effectiveness (or ineffectiveness) of competing designs.

While the existence of these putative alternative designs does not compel a finding that the ‘642 design was primarily ornamental, as TMS suggests, the evidence of functionality is also not so overwhelming as to compel a finding that the design disclosed in the ‘642 design patent is primarily functional, as EMI suggests. Although the examples of possible alternative designs TMS cites were not *intended* to be used with the triangular locking rings into which the beveled ends of the ‘642 design patent were to be inserted, a jury could reasonably conclude that the alternative designs TMS cites *could* be used “without adversely affect[ing] the utility of” the T.A.T. tourniquet. *Ethicon*, 796 F.3d at 1330. Accordingly, this is a question of fact for the jury, and TMS’s motion for summary judgment as to EMI’s affirmative defense of invalidity based on the alleged functionality of the ‘642 design patent (contained within EMI’s Second Affirmative Defense) is denied. Necessarily, then, TMS’s motion for summary judgment on its claim that EMI infringed the ‘642 design patent must also be denied.

2. Anticipation

EMI cannot, however, defend against TMS's infringement claim by asserting that the '642 design patent is invalid under 35 U.S.C. § 102 as anticipated by prior art. A design patent is anticipated if "in the eye of an ordinary observer, giving such attention as a purchaser usually gives," its design is "substantially the same" as that of the prior art. *Samsung Electronics Co., Ltd. v. Apple, Inc.*, 137 S. Ct. 429 (2016) (stating ordinary observer test in context of infringement) (citation omitted); *see also Int'l Seaway Trading Corp. v. Walgreens Corp.*, 589 F.3d 1233, 1237–40 (Fed. Cir. 2009) (stating that same ordinary observer test applies in context of anticipation). Establishing "design patent anticipation requires a showing that a single prior art reference is identical in all material respects to the claimed invention." *Door-Master Corp.*, 256 F.3d 1308, 1312 (Fed. Cir. 2001) (internal quotation marks omitted).

EMI argues that the '642 design patent was anticipated by design patents for a spark plug, U.S. Patent No. 1,360,946, and another for a drawer knob, U.S. Patent No. 1,855,482. Beyond the conclusory statement that "[e]ach of these two patents have an identical or at least substantially similar design to the ends of the handle of the tourniquet claimed in the '642 patent," DSOF ¶ 39; Karl Decl. ¶ 49, EMI has not provided any explanation or argument for how those patents anticipated TMS's '642 design patent. Nor is any such explanation apparent from the face of that prior art; neither prior art reference appears to even roughly approximate the '642 design such that a reasonable observer could confuse either of them with the '642 design. The spark plug and drawer knob are also not drawn to medical devices, let alone tourniquets, which "significantly limits the relevance of the prior art" in this case. *Columbia Sportswear North Am., Inc. v. Seirus Innovative Accessories*, 202 F. Supp. 3d 1186, 1196 (D. Or. 2016). "Courts examining design patents in relation to prior art cabin their analysis to prior art specific to the class of articles

identified in the design patent at issue.” *Id.*; see also *Cornucopia Products, LLC v. Dyson, Inc.*, Nos. CV 12-234, CV 12-294, 2012 WL 3094955, at *4 (D. Ariz. 2012) (“[T]he ordinary observer is assumed to be familiar with the prior art—i.e., all relevant preexisting designs for similar products.”). EMI’s invalidity defense based on anticipation therefore fails as a matter of law.

C. ‘064 and ‘620 Utility Patents

1. Validity

EMI has established that a reasonable jury could conclude by clear and convincing evidence that the ‘064 and ‘620 patents are invalid as obvious in light of prior art under 35 U.S.C. § 103, but not that those patents are invalid as anticipated by prior art under 35 U.S.C. § 102. EMI’s Second Affirmative Defense asserts that “[e]ach claim of the ‘064, ‘642 and ‘620 patents is invalid because it fails to satisfy the conditions for patentability specified in 35 U.S.C. § 100 et seq., including §§ 101, 102, 103, 112 and 171.” Answer at 35, ECF No. 17. The only of these statutory sections that EMI has invoked in support of the invalidity of the ‘064 and ‘620 utility patents are § 102 (anticipation) and § 103 (obviousness). Paragraph 43 of Karl’s declaration states:

The asserted claims are invalid over the McMillan and Brothers prior art patents. In particular, claims 1, 14, 15 and 17 of the ‘064 patent are anticipated by Brothers under 35 U.S.C. § 102. All of the asserted claims (1-5, 7-12 and 14-19 of the ‘064 patent and 1-4, 6-8, 10-11 and 13 of the ‘620 patent) are obvious [under 35 U.S.C. § 103] over Brothers alone or in combination with U.S. Patent No. 6,899,720 to McMillan issued May 31, 2005.

Karl Decl. ¶ 43, Exs. 1, 2, ECF Nos. 145, 145-1, 145-2; DSOF ¶ 34.

As to the § 102 grounds for invalidity, EMI asserted that it is “certain” that the Brothers prior art base is more flexible than “substantially rigid.” DSOF ¶ 29; Karl Decl. ¶ 35; Resp. 29, ECF No. 143. To establish anticipation under § 102, the proponent must show “that the four corners of a single, prior art document describe every element of the claimed invention” and that the prior art “disclose[s] those elements as arranged in the claim.” *Net MoneyIN, Inc. v. VeriSign,*

Inc., 545 F.3d 1359, 1369 (Fed. Cir. 2008) (citations and internal quotation marks omitted). If the Brothers prior art base was more flexible than the “substantially rigid” base of the ‘064 and ‘620 utility patents, then the Brothers prior art could not have described the “substantially rigid base” element of the claims of those patents to anticipate them. Karl’s claim chart also does not allege that Brothers discloses the elements in each claim of either patent. *See* Karl Decl., “The ‘064 Patent” and “The ‘620 Patent” charts following ¶ 43 at 9–18, ECF No. 145 (stating, *e.g.*, that claim 9 of ‘064 patent was obvious but not alleging facts to suggest it was anticipated and that claim 2 of ‘620 patent was obvious but not alleging facts to suggest it was anticipated). Having cited Brothers as the only basis for invalidity based on anticipation under 35 U.S.C. § 102, that basis for invalidity must fail.

EMI has, however, raised a genuine fact issue regarding whether the ‘064 and ‘620 utility patents are invalid under 35 U.S.C. § 103. Section 103 forbids issuance of a patent when “the differences between the subject matter sought to be patented and the prior art are such that the subject matter as a whole would have been obvious at the time the invention was made to a person having ordinary skill in the art.” 35 U.S.C. § 103. Obviousness is a question of law based upon underlying factual findings, which include: “(1) the scope and content of the prior art, (2) differences between the prior art and the claims at issue, (3) the level of ordinary skill in the pertinent art, and (4) the presence of objective indicia of nonobviousness such as commercial success, long felt but unsolved needs, failure of others, and unexpected results.” *Endo Parm. Inc. v. Actavis LLC*, 922 F.3d 1365, 1372–73 (Fed. Cir. 2019) (internal quotation marks omitted).

Karl’s claim charts explain how the claims would have been obvious to a person of ordinary skill in the art at the time of invention. *See* Karl Decl., “The ‘064 Patent” and “The ‘620 Patent” charts following ¶ 43 at 9–18, ECF No. 145 (stating, *e.g.*, as to claim 9 of the ‘064 patent that

“McMillan discloses a tourniquet 10 with a handle lock (24 or 28) attached to a base 12 and positioned to receive an end of a handle 20. It would have been obvious to one of ordinary skill in the art at the time of the alleged invention to modify Brothers as taught by McMillan in order to secure the handle to the base.”). TMS has not rebutted Karl’s claim charts regarding obviousness or otherwise argued that EMI has failed to establish a genuine dispute of material fact as to the invalidity of the ‘064 and ‘620 utility patents due to obviousness.

2. Infringement

A genuine issue of material fact also exists as to whether the T.A.T. tourniquet had a “substantially rigid base” and therefore infringed on the ‘064 and ‘620 utility patents.⁸ Analyzing whether a valid patent has been infringed involves a two-step inquiry. “The court must first interpret the claims to determine their scope and meaning. It must then compare the properly construed claims to the allegedly infringing device.” *Sunoco Partners Marketing & Terminals L.P. v. U.S. Venture, Inc.*, 339 F. Supp. 3d 803, 828 (N.D. Ill. 2018) (citing *Dynacore Holdings Corp. v. U.S. Phillips Corp.*, 363 F.3d 1263, 1273 (Fed. Cir. 2004)). The second step of this inquiry “is primarily factual.” *Sunoco*, 339 F. Supp. 3d at 828; *see also Medgraph, Inc. v. Medtronic, Inc.*, 843 F.3d 942, 949 (Fed. Cir. 2016) (“Infringement is a question of fact.”); *Freedman Seating Co. v. Am. Seating Co.*, 420 F.3d 1350, 1357 (Fed. Cir. 2005) (“[T]he second step is a question of fact.”). “Direct infringement can be found when a defendant makes a product containing each and every limitation set forth in a claim.” *Centrak, Inc. v. Sonitor Techs., Inc.*, 915 F.3d 1360, 1371 (Fed. Cir. 2019).

⁸ “Substantially rigid base” is the only claim element in dispute as to the issue of EMI’s alleged infringement of the ‘064 and ‘620 utility patents.

This Court completed the first step of this inquiry by construing the “substantially rigid base” term, which is the only claim term in dispute, as follows: “A base that provides sufficient rigidity to avoid binding and crushing while being flexible enough for use on a limb and facilitating carriage and storage.” Mem. Op. and Order dated Sept. 26, 2017 at 14, ECF No. 126. Now that the claim term has been construed, what is left is a factual question regarding whether the T.A.T. tourniquet has a “substantially rigid base” as that term has been construed by this Court. TMS has argued that “rigidity” is “a matter of degree.” Mem. Op. and Order dated Sept. 26, 2017 at 10, ECF No. 126; *see also id.* at 10–11 (“TMS is seeking a claim construction indicating that the base has some degree of flexibility, and which places the term between either ends of a continuum beginning with ‘flexible’ on one extreme end of the spectrum and ‘rigid’ on the other.”).

TMS has attached to its motion a demonstration video and cites to testimony from Johnson and Hester that roughly amount to statements that the T.A.T. tourniquet base is substantially rigid. EMI has submitted Karl’s competing interpretation of the degree of rigidity, roughly amounting to a statement that the base of the T.A.T. tourniquet is more flexible than substantially rigid. A reasonable jury could watch the demonstration video and consider those statements and reasonably conclude that the T.A.T. tourniquet does not have a “base that provides sufficient rigidity to avoid binding and crushing while being flexible enough for use on a limb and facilitating carriage and storage.” Where the base of the T.A.T. tourniquet falls on the spectrum of rigidity as a matter of degree is a fact question that must be left to the jury.

D. False Representation

A reasonable jury could conclude that EMI did not falsely advertise its T.A.T. tourniquet by using images of the SOF tourniquet on its website and in its product catalogs. To prevail on a false advertising claim under the § 43(a) of the Lanham Act, codified at 15 U.S.C. § 1125(a), a plaintiff must prove that “(1) the defendant made a material false statement of fact in a commercial

advertisement; (2) the false statement actually deceived or had the tendency to deceive a substantial segment of its audience; and (3) the plaintiff has been or is likely to be injured as a result of the false statement.” *Eli Lilly and Co. v. Arla Foods, Inc.*, 893 F.3d 375, 381–82 (7th Cir. 2018). Two types of statements are actionable under the Lanham Act: “those that are literally false and those that are literally true but misleading.” *Id.* at 382. Because a “literally false statement will necessarily deceive consumers . . . extrinsic evidence of actual consumer confusion is not required” to establish liability for such statements, but for literally true but misleading statements to be actionable, “the plaintiff ordinarily must produce evidence of actual consumer confusion.” *Id.* Here, TMS has not produced evidence of actual consumer confusion stemming from EMI’s use of the tourniquet image. TMS must therefore show that EMI’s use of the image was a literally false statement.

While a company’s use of an image of a competitor’s product in advertising its own product may give rise to liability under § 43(a), liability under such circumstances “is not automatic.” *Nat’l Presto Indus., Inc. v. Hamilton Beach, Inc.*, 1990 WL 208594, at *7 (N.D. Ill. Dec. 12, 1990) (quoting *Vibrant Sales, Inc. v. New Body Boutique, Inc.*, 652 F.2d 299, 304 (2d Cir. 1981); see also *Flowserve Corp. v. Hallmark Pump Co.*, No. 4:09-cv-0675, 2011 WL 1527951, at *7 (S.D. Tex. Apr. 20, 2011) (“In **most** situations, the use of a photograph of the plaintiff’s product to advertise defendant’s product is a § 43(a) violation.”) (emphasis added); *Nat’l Presto Indus., Inc. v. Hamilton Beach, Inc.*, No. 88 C 10567, 1990 WL 208594, at *8 (N.D. Ill. Dec. 12, 1990) (“[T]he language of the Lanham Act is very broad and **may** certainly embrace the defendant’s use of a photo of the plaintiff’s product in advertising its own.”) (emphasis added). “One who uses a photograph of his competitor’s unpatented and untrademarked product to advertise his own wares

may be guilty of false representation if the product is not identical to the one he is prepared to deliver.” *Vibrant Sales, Inc. v. New Body Boutique, Inc.*, 652 F.2d 299, 304 (2d Cir. 1981).⁹

Far from claiming that EMI’s use of a photo of the SOF tourniquet falsely represented what consumers who purchased the T.A.T. tourniquet would receive, TMS asserts that the “T.A.T. tourniquet is a visual twin of the SOF tourniquet” and that the tourniquets’ appearance is “virtually indistinguishable.” Mem. 5, ECF No. 141; *see also id.* (“Perusal of the photographs disposes of any reasonable argument that the accused T.A.T. tourniquet is visually distinguishable from its authorized patented counterpart.”); PSOF ¶ 22 (asserting that the T.A.T. tourniquet “copies virtually every feature” and “replicates the appearance” of the SOF tourniquet). Although some of these statements are in the section of TMS’s brief relating to the ‘642 design patent, the statements are not limited to the handle end design. *See, e.g.*, Mem. 5, ECF No. 141 (“A side-by-side comparison of the SOF tourniquet to the T.A.T. tourniquet illustrated below, shows that the T.A.T. tourniquet is a visual twin of the SOF tourniquet.”).

TMS argues that the T.A.T. tourniquet uses lower-quality stitching, is covered in coating that chips more easily, has a cap screw that rusts more easily, and lacks pin covers. TMS has also stated generally that the “T.A.T. inferiorities cheapen the appearance of the tourniquet.” Mem. 16., ECF No. 141. But these are qualities that are not discernible from the photo at issue. TMS has not alleged how the picture EMI used to advertise the T.A.T. tourniquet misrepresents those inferiorities or creates an impression that the customer will receive a tourniquet of superior quality

⁹ The quoted language refers to a competitor’s “unpatented and untrademarked” product. For purposes of the present motion, all reasonable inferences must be construed in EMI’s favor. EMI has shown that a material fact dispute exists as to whether TMS’s patents are invalid, and this Court previously denied TMS’s motion for summary judgment on TMS’s trademark claims. *See* Order dated Sept. 21, 2015, ECF No. 62. Further, TMS has not argued why that qualification should prevent the Court from applying the same principle enunciated in *Vibrant Sales* here.

to the one that EMI is prepared to deliver. Nor do the pictures at issue appear to make any representations about the ability of the T.A.T. tourniquet to withstand wear and tear. Although a customer might be able to discern differences in the quality of the stitching or the lack of pin covers when viewing a close-up image of those components, the pin covers and the stitching themselves can hardly be seen in the accused images (if at all), let alone any material differences in the quality of those components. There is also evidence upon which a jury could base a reasonable conclusion that in using the tourniquet photo, EMI did not have the “kind of intent to misrepresent which is the cornerstone of a money damage [false representation] action.” *Can-Am Eng’g Co. v. Henderson Glass, Inc.*, 814 F.2d 253, 257 (6th Cir. 1987). EMI contends that it innocently used the photograph from its supplier, and that if the photograph depicted the SOF tourniquet, EMI was not aware of that fact.

Under these circumstances, the Court cannot conclude as a matter of law that EMI is liable for false representation based on the use of the tourniquet photograph. *See Merchant & Evans, Inc. v. Roosevelt Bldg. Prods. Co.*, 963 F.2d 628, 636 (3d Cir. 1992) (“Because the appearance of the two products is identical, it is difficult to see how [defendant’s] alleged use of [plaintiff’s product] in its photograph could be misleading.”); *see also Compaq Computer Corp. v. Procom Tech., Inc.*, 908 F. Supp. 1409, 1426–27 (S.D. Tex. 1995) (“Given that the differences between the displayed product and the actual product are slight, there is little chance that a customer could be misled by the photograph in [the defendant’s] ads.”). TMS has not made any arguments that it is entitled to summary judgment on its unfair competition counts (Counts X and XI) that are different from those it raises in support of summary judgment on the Lanham Act false representation count (Count VIII). Accordingly, TMS’s motion for summary judgment is denied as to all counts relating to the use of the tourniquet photograph.

E. TACMED Counterclaims

Genuine issues of material fact also remain as to all of EMI's TACMED counterclaims. As this Court noted when ruling on the defendant's summary judgment motion, "[t]he facts that bear on [the TACMED trademark] question are in substantial dispute," and "there is a material fact dispute as to whether the TACMED mark is valid." Order dated Sept. 26, 2017 at 8, 7, ECF No. 125; *see also id.* at 10 ("[T]here is a material dispute of fact as to whether the TACMED mark is protectable."). This Court thoroughly discussed in that opinion the arguments the parties raise here in support of and against TMS's motion for summary judgment on the TACMED counterclaims; that discussion is incorporated here by reference. *See* Order dated Sept. 26, 2017 at 7–10, ECF No. 125. The facts were in substantial dispute then, and TMS has pointed to no evidence or argument that would lead the Court to believe that the facts on this question are now so one-sided that TMS is entitled to summary judgment on the same counterclaims.

Instead of pointing to facts that were not available at the time of briefing on the previous motion for summary judgment, TMS argues that the case of the law doctrine somehow entitles it to prevail. TMS badly misconstrues this Court's prior opinion by wrongly suggesting that the Court's ruling that EMI had *failed to establish* that the TACMED mark was valid as a matter of law now compels a ruling that *no reasonable jury could find* that the mark was valid. The Court did not make the latter finding then, and TMS has not provided a basis for the Court to make such a finding now. Indeed, when drawing all reasonable inferences *against* EMI, this Court concluded that there were substantial factual disputes as to the TACMED counterclaims. *See* Order dated Sept. 26, 2017 at 7, 8, 10, ECF No. 125 (emphasizing that the facts relevant to the TACMED counterclaims are in substantial dispute). In moving for summary judgment on those same counterclaims, TMS faces a difficult task because it must show that the factual picture has changed

so drastically that TMS is now entitled to judgment as a matter of law even though those inferences are now construed *in favor* of EMI.

As to whether the TACMED mark is descriptive or suggestive, the Court held that a “material dispute of fact exists . . . as to whether [EMI]’s use of the mark is . . . descriptive.” Order dated Sept. 26, 2017, ECF No. 125; *see also Sands, Taylor & Wood Co. v. Quaker Oats Co.*, 978 F.2d 947, 952 (7th Cir. 1992) (“[C]lassification of a term as ‘descriptive’ or ‘suggestive’ is a factual determination.”). And if the mark was suggestive as used by EMI, EMI need not show secondary meaning to establish that EMI had a valid TACMED trademark. *See Two Pesos, Inc. v. Taco Cabana, Inc.*, 505 U.S. 763, 768 (1992) (plaintiffs need not show secondary meaning to establish trademark rights in suggestive mark). But even if EMI needed to show secondary meaning, “[t]he facts that bear on this question are in substantial dispute.” Order dated Sept. 26, 2017 at 8, ECF No. 125. For the same reasons summary judgment was previously denied, summary judgment is denied on each of EMI’s TACMED trademark infringement counterclaims.¹⁰

¹⁰ TMS filed a Notice of Supplemental Information, ECF No. 165, stating that after the U.S. Patent and Trademark Office rejected EMI’s application to register TACMED because it found that the mark was descriptive, EMI amended its trademark application on the “Principal Register” to become an application on the “Supplemental Register.” The Supplemental Register is where marks may be registered that are not inherently distinctive but that may become registrable on the Principal Register upon the acquisition of secondary meaning. *Real Foods Pty Ltd. v. Frito-Lay N. Am., Inc.*, 906 F.3d 965, 972 n.3 (Fed. Cir. 2018). TMS contends that registering on the Supplemental Register amounts to a concession that the mark is not inherently distinctive. TMS, however, has not pointed to any such express concession by EMI. And the mere act of registering on the Supplemental Register cannot be viewed as a concession that the mark is not inherently distinctive, because the registration scheme contemplates that a mark registered on the Supplemental Register may later be registered on the Principal Register on the basis that it is inherently distinctive. *See Park ‘N Fly, Inc. v. Dollar Park and Fly, Inc.*, 469 U.S. 189, 212 n.13 (1985) (describing process whereby applicant may get mark from Supplemental Register to Principal Register, including by arguing that mark is inherently distinctive) (citing 1 J. McCarthy, *Trademarks and Unfair Competition* § 19:7 (1984)); *see also California Cooler, Inc. v. Loretto Winery, Ltd.*, 774 F.2d 1451, 1454 (9th Cir. 1985) (declining to hold that “a manufacturer which registers on the [S]upplemental [R]egister comes away with fewer rights than it would have had if it had not sought registration at all”). And even if the mere act of registering on the Supplemental

F. Tortious Interference

Genuine issues of material fact also exist as to whether TMS tortiously interfered with EMI's contracts and reasonable business expectancies. To prevail under a tortious interference with a contract theory under Illinois law, a plaintiff must establish the following elements: "(1) the existence of a valid and enforceable contract between the plaintiff and a third party; (2) defendant's awareness of the contract; (3) defendant's intentional and unjustified inducement of a breach; (4) defendant's wrongful conduct caused a subsequent breach of the contract by the third party; and (5) damages." *Echo, Inc. v. Timberland Machines & Irr., Inc.*, 661 F.3d 959, 968 (7th Cir. 2011). And to prevail on a tortious interference with prospective economic advantage theory, the plaintiff must establish "(1) a reasonable expectancy of entering into a valid business relationship, (2) the defendant's knowledge of the expectancy, (3) an intentional and unjustified interference by the defendant that induced or caused a breach or termination of the expectancy, and (4) damage to the plaintiff resulting from the defendant's interference." *McCoy v. Iberdrola Renewables, Inc.*, 760 F.3d 674, 685 (7th Cir. 2014) (citation omitted).

EMI's reasonable expectancy of continuing or entering into valid business relationships with its distributors—and EMI's knowledge of those relationships—is evidenced by TMS's decision to send its letters to those customers. TMS did not, of course, select those customers at random; TMS would not have bothered sending such distributors cease-and-desist letters if TMS thought there was no business relationship from which to demand that they cease-and-desist. And even if there was no overarching distribution agreement that required EMI's distributors to make

Register amounted to a concession that the mark is not inherently distinctive, TMS has not pointed to any new evidence since the Court ruled on the previous motion for summary judgment to show that there is no longer a factual dispute as to whether EMI could establish secondary meaning in the mark.

future purchases from EMI, there is ample evidence upon which a reasonable jury could rest a conclusion that EMI had valid business expectancies and contracts with its distributors. EMI received purchase orders, issued invoices, and received payment for products that it shipped to distributors. After receiving the cease-and-desist letter, some EMI distributors stopped purchasing EMI products and others returned conforming products; some even cited the cease-and-desist letter as the basis for the changed business relationship. Although TMS contends that it sent the letters in a good-faith attempt to protect its intellectual property rights, EMI has provided evidence that could give rise to a reasonable inference that the letters were motivated by an unjustified desire to drive EMI out of business. *See, e.g.*, DSOF ¶ 23; Defs.’ Prior Statement of Facts, Ex. 35, ECF No. 110-35 (Johnson stating that he hoped EMI would be “out of business in a few months.”).

TMS’s arguments in support of summary judgment on the tortious interference issue rest largely on its incorrect assertion that the “testimony of an interested party to a suit, without any corroborating evidence or documentary support to substantiate the testimony, fails to raise a materially disputed issue of fact.” Reply 11, ECF No. 152 (citing *Pugh v. City of Attica, Indiana*, 259 F.3d 619, 625 (7th Cir. 2001)). While “*conclusory* allegations, unsupported by specific facts, will not suffice” to defeat summary judgment, *Payne v. Pauley*, 337 F.3d 767, 773 (7th Cir. 2003) (emphasis added), the self-serving nature of testimony or lack of corroborating evidence or documentary support does not provide a basis for declining to consider such evidence on a motion for summary judgment, *see id.* (seeking to “lay[] to rest the misconception that evidence presented in a ‘self-serving’ affidavit is never sufficient to thwart a summary judgment motion”). “Provided that the evidence meets the usual requirements for evidence presented on summary judgment—including the requirements that it be based on personal knowledge and that it set forth specific

facts showing that there is a genuine issue for trial—a self-serving affidavit is an acceptable method for a non-moving party to present evidence of disputed material facts.” *Id.*

* * *

For the reasons stated above, TMS’s partial motion for summary judgment, ECF No. 135, is granted in part. EMI’s Second Affirmative Defense survives summary judgment only to the extent that it asserts 35 U.S.C. § 171 (functionality) as a basis for invalidity of the ‘642 design patent and 35 U.S.C. § 103 (obviousness) as a basis for invalidity of the ‘064 and ‘620 utility patents. Summary judgment in favor of TMS is granted as to EMI’s Third and Eleventh Affirmative Defenses, and EMI’s First Affirmative Defense is stricken. TMS’s motion for summary judgment is otherwise denied.

Date: June 11, 2019

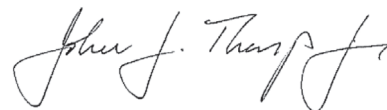

John J. Tharp, Jr.
United States District Judge