

**UNITED STATES DISTRICT COURT
FOR THE NORTHERN DISTRICT OF ILLINOIS
EASTERN DIVISION**

MIDWEST INNOVATIVE PRODUCTS, LLC,

Plaintiff,

v.

KINAMOR, INC., and KINNECO, LLC,

Defendants.

No. 16 CV 11005

Judge Manish S. Shah

MEMORANDUM OPINION AND ORDER

Midwest Innovative Products, LLC, alleges that defendants Kinamore Inc., and Kinneco, LLC, infringe on Midwest's patent for electrical cord covers. Defendants move to dismiss for failure to state a claim. For the following reasons, the motion is denied.

I. Background

Plaintiff Midwest Innovative Products, LLC, sells covers for electrical cord connections and owns U.S. Patent No. 9,413,101, entitled "Electrical Cord Connection Covering Techniques," and issued on August 9, 2016. [1-1].¹ Defendants Kinamor, Inc., and Kinneco, LLC, make and sell electrical cord covers called "CordSafe." In July 2016—before the '101 patent issued—and later in August and October 2016, Midwest sent defendants cease-and-desist letters, contending that defendants' CordSafe system infringed at least claim 1 of the '101 patent. Shortly

¹ Bracketed numbers refer to entries on the district court docket. The allegations in the complaint, [1], are taken as true for resolving the motion to dismiss.

after exchanging these communications, Midwest sued defendants, alleging that their CordSafe product infringes at least claim 1 of the '101 patent.

The patent describes a system for covering connections between electrical cords. It describes parts of the covering system called “compression portions.” The “compression portions,” which may be made of foam, create a water or weather resistant seal around the electrical connection and cords by compressing and filling in voids inside the covering. The patent describes compression portions, at times, as having grooves and forming channels that surround the cords. Figure 2C in the patent provides a simple visual depiction of an embodiment of the system, with the compression portion in gray:

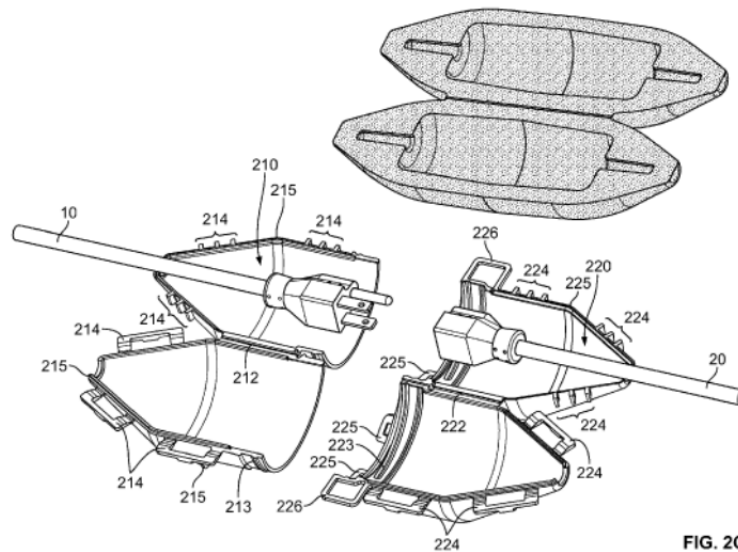

FIG. 2C

II. Legal Standards

To survive a motion to dismiss under Federal Rule of Civil Procedure 12(b)(6), a complaint must contain factual allegations that plausibly suggest a right to relief. *Ashcroft v. Iqbal*, 556 U.S. 662, 677–78 (2009). The court must construe all factual allegations as true and draw all reasonable inferences in the plaintiff's

favor, but the court need not accept legal conclusions or conclusory allegations. *Id.* at 678–79. “[D]ocuments that are attached to the complaint, documents that are central to the complaint and are referred to in it, and information that is properly subject to judicial notice” may be considered on a motion to dismiss. *Williamson v. Curran*, 714 F.3d 432, 436 (7th Cir. 2013); Fed. R. Civ. P. 10(c). Midwest attached to its complaint a copy of the ’101 patent. [1-1]. Defendants attached several documents to their motion to dismiss, including: Midwest’s cease-and-desist letters ([22-1], [22-2], [22-3]), defendants’ letter in response ([22-4]), a patent application ([22-5]), and parts of the ’101 patent prosecution history ([30-1], [30-2]). In response, Midwest also attached to its opposition brief the prosecution history for the ’101 patent and for two other patent applications. [28].

I consider only the ’101 patent in resolving defendants’ motion to dismiss. The cease-and-desist letters are referred to in the complaint (except for defendants’ response letter), but while they may be central to Midwest’s allegation of willful infringement, they are not particularly relevant to the issues raised in this motion to dismiss. Other than the ’101 patent, which was attached to the complaint and central to it, the patent application and prosecution histories attached to the parties’ briefs are not considered at this time. Midwest does not object to judicial notice of these materials, *see* [27] at 9 n.4, 12 n.5, but I decline to take judicial notice of them. A court may take judicial notice of patents or patent applications, *Anderson v. Kimberly-Clark Corp.*, 570 Fed. App’x 927, 932 n.4 (Fed. Cir. 2014), and there may be situations where judicial notice of a prosecution history is proper at the

motion to dismiss stage. This is not such a situation. The patent application and the prosecution histories are not referred to in Midwest’s complaint and are not central to its claim for infringement. The exception to considering materials outside the complaint in resolving a Rule 12(b)(6) motion is a narrow one, and “[i]t is not intended to grant litigants license to ignore the distinction between motions to dismiss and motions for summary judgment.” *Levenstein v. Salafsky*, 164 F.3d 345, 347 (7th Cir. 1998).

These materials are also not considered because defendants’ motion to dismiss, in large part, improperly seeks resolution of issues on the merits. Defendants seek a determination of the substantive merits of the controversy between the parties—their motion essentially asks for the court to construe claim 1 and compare it to their allegedly infringing CordSafe product. *See, e.g., Liquid Dynamics Corp. v. Vaughan Co., Inc.*, 355 F.3d 1361, 1367 (Fed. Cir. 2004) (resolving a patent infringement claim requires construing the patent claims and then comparing them to the allegedly infringing device). “[T]he purpose of a motion under Federal Rule 12(b)(6) is to test the formal sufficiency of the statement of the claim for relief; the motion is not a procedure for resolving a contest between the parties about the facts or the substantive merits of the plaintiff’s case.” 5B Wright & Miller Fed. Practice & Procedure Civil § 1356 (3d ed.). Here, the parties seek to admit materials outside the complaint to resolve matters of claim construction and invalidity based on anticipation and priority—matters typically resolved at later stage of litigation. When a defendant attaches to its motion to dismiss materials

outside the complaint and not central to it, “the court must either convert the 12(b)(6) motion into a motion for summary judgment under Rule 56 and proceed in accordance with the latter rule, or exclude the documents attached to the motion to dismiss and continue under Rule 12.” *Levenstein*, 164 F.3d at 347. Converting the defendants’ motion to a motion for summary judgment would be premature. Therefore, I do not consider the patent applications and prosecution histories submitted by the parties.

III. Analysis

Defendants move to dismiss Midwest’s infringement action, asserting that their CordSafe product lacks a two-groove configuration required in claim 1 and that the ’101 patent is invalid as anticipated over Midwest’s earlier patent publication.

A. Infringement Claim

Defendants contend that Midwest does not plausibly allege that their CordSafe product infringes the ’101 patent because defendants’ CordSafe product lacks a two-groove configuration in claim 1. Midwest responds that the two-groove configuration in claim 1 is a mere typographical error. As a threshold issue, Midwest also insists that noninfringement is an affirmative defense that it was not required to plead around. “[A] plaintiff ordinarily need not anticipate and attempt to plead around affirmative defenses,” and dismissal on an affirmative defense is only appropriate when a plaintiff pleads itself out of court on the face of the complaint. *Hyson USA, Inc. v. Hyson 2U, Ltd.*, 821 F.3d 935, 939 (7th Cir. 2016). Under 35 U.S.C. § 282(b), “[n]oninfringement” is specifically listed as a “defense” to

a claim for patent infringement, along with invalidity. But unlike invalidity, which concerns allegations outside of the plaintiff's prima facie case and is the defendant's burden to prove, noninfringement is not just a defense but also the failure of the plaintiff's prima facie cause of action for infringement. In that sense, it is not truly an affirmative defense—a plaintiff alleging infringement always has the ultimate burden to prove infringement by a preponderance of the evidence. *Technology Licensing Corp. v. Videotek, Inc.*, 545 F.3d 1316, 1327 (Fed. Cir. 2008).

Midwest must plausibly allege that the defendants infringed at least one claim of the '101 patent. Claim 1 provides, in part, that the claimed invention is:

1. An electrical cord covering system for covering a connection of a first electrical cord including a first plug and a first cable with a second electrical cord including a second plug and a second cable, wherein the electrical cord covering system comprises:

a first covering portion including:

a first casing piece and a second casing piece connected by a hinge;

a first securing portion attached to the first casing piece, and a second securing portion attached to the second casing piece, wherein the first securing portion and the second securing portion are configured to mate to hold the first covering portion in a closed position;

[. . .]

a first compression portion abutting the first casing piece, wherein the first compression portion comprises a groove configured to receive a portion of the first cable;

a second compression portion abutting the second casing piece, wherein the second compression portion comprises a groove configured to receive a portion of the first cable, wherein the first compression portion and the second compression portion are configured to engage with each other to form a channel, and

wherein the channel surrounds a portion of the first cable when the first covering portion is in the closed position such that a compression seal is formed around the first cable at the cable aperture of the first covering portion;

a second covering portion including:

a third casing piece and a fourth casing piece connected by another hinge;

a third securing portion attached to the third casing piece, and a fourth securing portion attached to the fourth casing piece, wherein the third securing portion and the fourth securing portion are configured to mate to hold the second covering portion in a closed position;

[. . .]

a third compression portion abutting the third casing piece, wherein the third compression portion comprises a groove configured to receive a portion of the second cable; and

a fourth compression portion abutting the fourth casing piece, wherein the second compression portion comprises a groove configured to receive a portion of the second cable, wherein the third compression portion and the fourth compression portion are configured to engage with each other to form a channel, and wherein the channel surrounds a portion of the second cable when the second covering portion is in the closed position such that a compression seal is formed around the second cable at the cable aperture of the second covering portion.

Midwest's complaint alleges that, along with meeting the other limitations in claim 1, defendants' CordSafe product meets claim 1's limitation about "compression portions" because the CordSafe product "includes two compression portions, one abutting each casing piece" and because "[e]ach compression portion comprises a groove configured to receive a portion of the cable." [1] ¶ 19. Defendants contend, however, that claim 1 requires the "second compression portion" to have *two* grooves, one to receive a portion of the first cable and one to receive a portion of

the second cable. Defendants cite claim 1's requirement that the electrical covering system include: "a second compression portion abutting the second casing piece, *wherein the second compression portion comprises a groove configured to receive a portion of the first cable*" and "a fourth compression portion abutting the fourth casing piece, *wherein the second compression portion comprises a groove configured to receive a portion of the second cable.*" [1-1] at col. 10, ll. 9–12, 54–57 (emphasis added). Midwest does not dispute that, as currently written, claim 1 requires the "second compression portion" to have two grooves (one for each cable). Midwest also does not dispute that defendants' CordSafe product only has one groove. Midwest argues, however, that the second reference to a "second compression portion" is a typographical error, obvious on the face of the patent, and should instead read: "a fourth compression portion abutting the fourth casing piece, wherein the *fourth* compression portion comprises a groove configured to receive a portion of the second cable."

A district court can correct a patent only if: (1) "the error is evident from the face of the patent," *H-W Technology, L.C. v. Overstock.com, Inc.*, 758 F.3d 1329, 1333 (Fed. Cir. 2014), (2) "the correction is not subject to reasonable debate based on consideration of the claim language and the specification," *Novo Industries, L.P. v. Micro Molds Corp.*, 350 F.3d 1348, 1357 (Fed. Cir. 2003), and (3) "the prosecution history does not suggest a different interpretation of the claims." *Id.* In deciding whether it has authority to correct a claim, a district court must consider any proposed correction from the point of view of one skilled in the art. *CBT Flint*

Partners, LLC v. Return Path, Inc., 654 F.3d 1353, 1358 (Fed. Cir. 2011) (citing *Ultimax Cement Mfg. Corp. v. CTS Cement Mfg. Corp.*, 587 F.3d 1339, 1353 (Fed. Cir. 2009)).² Midwest maintains that its proposed correction is supported by the structure of claim 1 and the specification. According to Midwest, if the error is accounted for, claim 1 is structured in two parts: (1) the first and second compression portions, casing pieces, and securing portions corresponding to the first covering portion for the first cable, and (2) the third and fourth compression portions, casing pieces, and securing portions corresponding to the second covering portion for the second cable. [1-1] at col. 9, l. 47 to col. 10, l. 64; *see* [27] at 12. Midwest also argues that this correction is supported by the specification and figures, which show that each covering portion covers one cable and show that the compression portions may be formed by left and right parts. [1-1] at col. 6, ll. 48–52. Defendants contend that Midwest’s proposed correction is subject to dispute and note that the specification describes at least one embodiment where the compression portion has two grooves. [1-1] at col. 5, ll. 13–15; *see* [27] at 8.

Whether the language in claim 1 of the ’101 patent is correctable is an issue more appropriately resolved in the context of claim construction, and I decline to skip to that stage now. The Federal Circuit has typically addressed patent correction hand-in-hand with claim construction or after claim construction. *See*,

² Midwest has not sought a certificate of correction from the USPTO under 35 U.S.C. § 255. A certificate of correction is only effective for causes of action arising after it was issued. *Novo Indus.*, 350 F.3d at 1356 (citing *Southwest Software, Inc. v. Harlequin Inc.*, 226 F.3d 1280, 1294 (Fed. Cir. 2000)).

e.g., *H-W Tech.*, 758 F.3d at 1333 (court properly declined to correct patent after claim construction); *CBT Flint*, 654 F.3d at 1358 (addressing whether there was a correctable error in terms of claim construction); *Novo Indus.*, 350 F.3d at 1353–58 (addressing whether district court lacked authority to correct error in claim during claim construction). While maintaining that the error and its correction are obvious on the face of the patent, Midwest does not object to claim construction now, if necessary. Defendants argue that no additional information is needed to construe claim 1 and that there is precedent for construing claims at the pleadings stage. *See, e.g., Atlas IP, LLC v. Exelon Corp.*, 189 F.Supp.3d 768, 778 (N.D. Ill. 2016) (dismissing infringement claim where it depended on claim construction that was wrong as a matter of law), *aff'd sub nom. Atlas IP, LLC v. Commonwealth Edison Co.*, No. 2016-2203, 2017 WL 1906917 (Fed. Cir. May 9, 2017).

But it is premature to address patent correction at this stage, before the parties have addressed the point of view of one skilled in the art.³ *See CBT Flint*, 654 F.3d at 1358 (“[I]n deciding whether it ha[s] authority to correct a claim, a district court must consider any proposed correction from the point of view of one skilled in the art.”). Although the parties have tacitly agreed to claim construction at this stage if the court finds it necessary, claim construction is generally inappropriate on a motion to dismiss because claims are afforded “their broadest possible construction” at the pleading stage. *In re Bill of Lading Transmission &*

³ Midwest conclusorily states that the purported typographical error is clear to one of skill in the art, but Midwest does not even address level of skill in the art and acknowledges that this issue is more appropriately resolved at claim construction. [27] at 8.

Processing Sys. Patent Litig., 681 F.3d 1323, 1343 n.13 (Fed. Cir. 2012) (reversing grant of Rule 12(b)(6) motion to dismiss, noting that “claim construction at the pleading stage—with no claim construction processes undertaken—was inappropriate”). Moreover, claim construction must take into account the meaning of the claim to a person of ordinary skill in the art at the time of the invention, *Phillips v. AWH Corp.*, 415 F.3d 1303, 1313 (Fed. Cir. 2005), and the parties have not yet developed that issue. Resolution of the purported error would also require analyzing the ’101 patent’s prosecution history, which is outside the complaint.

Atlas, cited by defendants, involved a different scenario where a Rule 12(b)(6) dismissal was appropriate because no reasonable claim construction would have allowed the plaintiff to state a claim for patent infringement—it did not involve an assertion that there was an error in the patent. *Atlas IP, LLC v. Exelon Corp.*, 189 F.Supp.3d 768, 778 (N.D. Ill. 2016). Although defendants reserve noninfringement arguments based on other limitations, [30] at 1 n.1, they do not dispute that if claim 1 of the ’101 patent is corrected per Midwest’s request, Midwest has stated a claim for patent infringement against defendants based on their CordSafe product. Ultimately, Midwest might not prevail on its claim for patent infringement. But giving the ’101 patent its broadest possible construction in this case, which accounts for a typographical error, Midwest has sufficiently stated a claim for patent infringement against defendants.

B. Invalidity Defense

Defendants also move for dismissal of Midwest’s complaint on their invalidity defense, arguing that the ’101 patent is invalid as anticipated over Midwest’s earlier

patent publication. Unlike a failed prima facie case for infringement, invalidity is an affirmative defense that is the defendants' burden to prove, *Technology Licensing*, 545 F.3d at 1327, and *Midwest* was not required to plead around it. *Hyson*, 821 F.3d at 939. Defendants' invalidity defense does not seek to test whether *Midwest* has stated a claim for relief. Instead, defendants' motion to dismiss seeks to introduce materials outside the pleadings in order to establish the merits of its invalidity defense. A Rule 12(b)(6) motion "is not a procedure for resolving a contest between the parties about the facts or the substantive merits of the plaintiff's case." 5B Wright & Miller Fed. Practice & Procedure Civil § 1356 (3d ed.). Resolving this invalidity defense requires analyzing matters outside the pleadings and on the merits, and therefore is not amenable to resolution on a Rule 12(b)(6) motion.

IV. Conclusion

Defendants' motion to dismiss, [21], is denied.

ENTER:



Manish S. Shah
United States District Judge

Date: 5/31/2017