

Exh. BB

PUB-NO: DE003321306A1
DOCUMENT-IDENTIFIER: DE 3321306 A1
TITLE: Motor vehicle trailer, preferably caravan

Abstract Text - FPAR (1):

CHG DATE=19990617 STATUS=O> A motor vehicle trailer, preferably a caravan, is described, having a rounded vehicle front, cover strips which are constructed as weather strip rails laterally covering the joints between the essentially plane side walls of the trailer, its arched front wall and the roof. The weather strip rails serve for the retraction of an awning or the like. The weather strip rails are of continuous construction for the purpose of inserting the awning or the like without difficulty.

Title of Patent Publication - TTL (1):

Motor vehicle trailer, preferably caravan

Nummer: 33 21 306
Int. Cl.³: B 60 P 3/32
Anmeldetag: 13. Juni 1983
Offenlegungstag: 13. Dezember 1984

3321306

113. 1/4

FIG 1

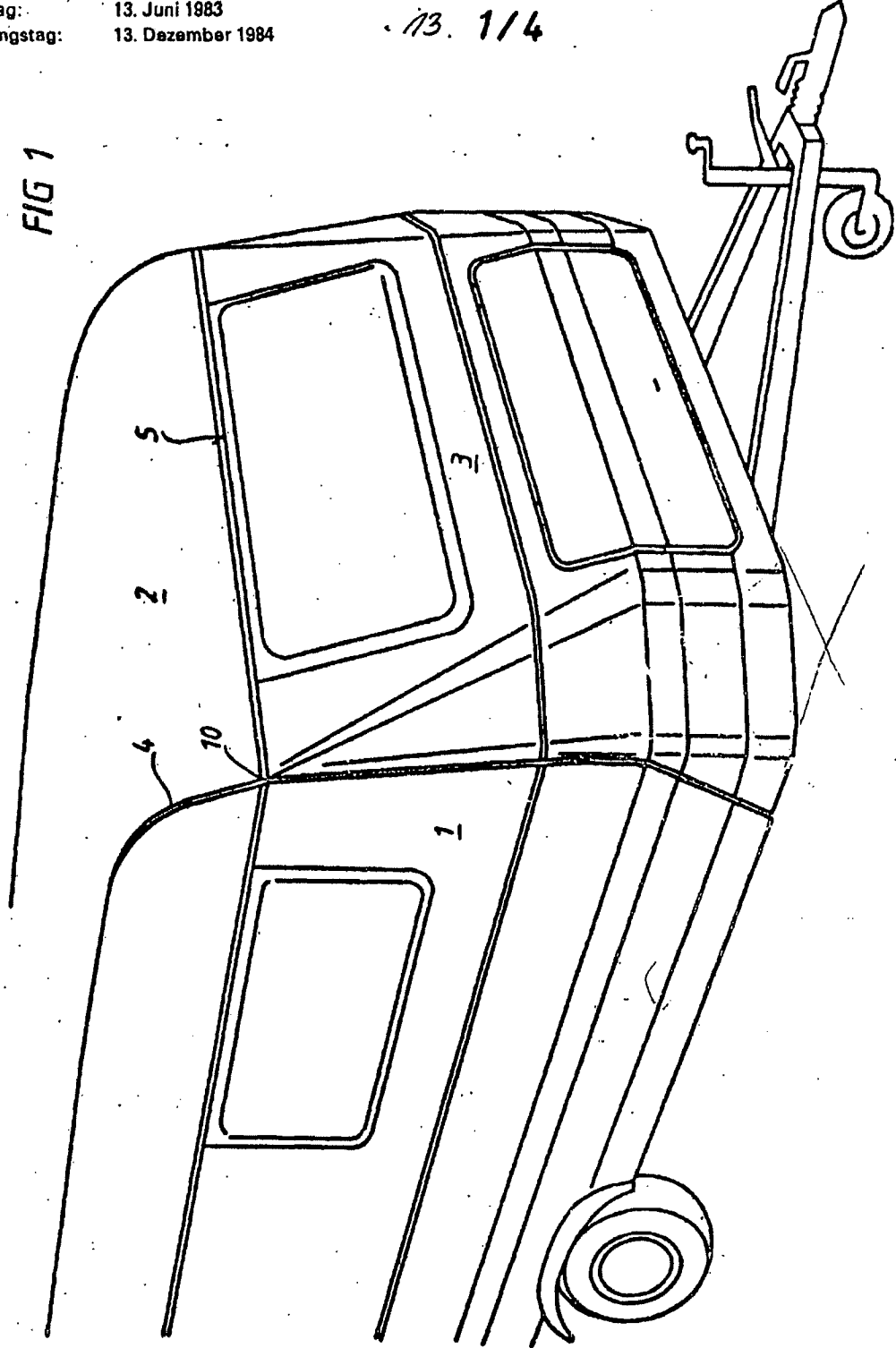

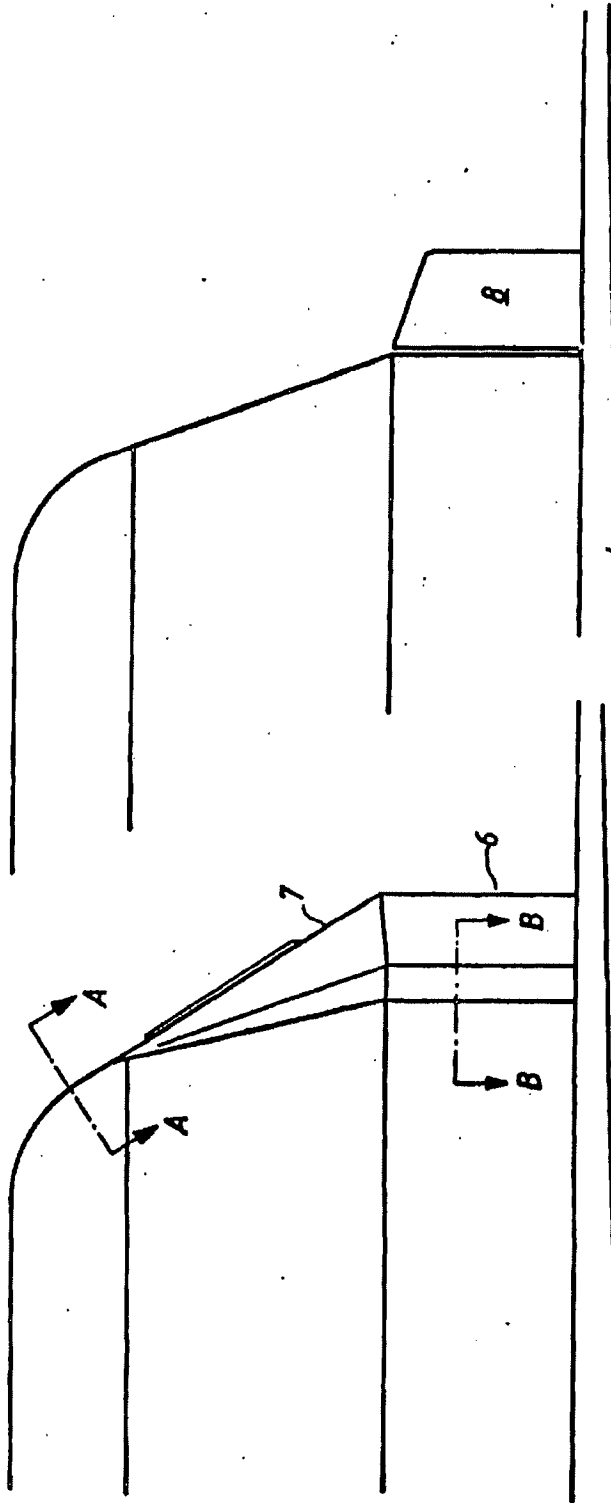

FIG 3

FIG 2

119. 3/4

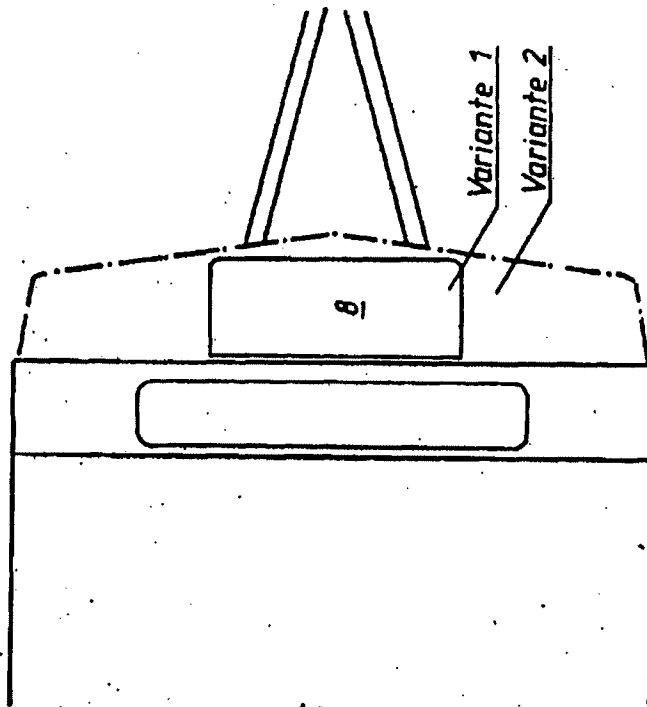

FIG 5

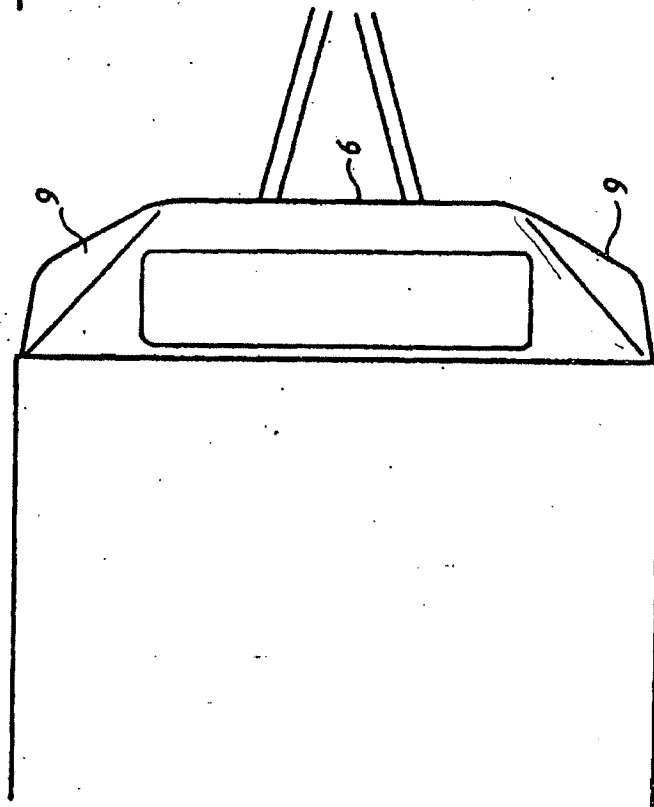

FIG. 4

12 4/4

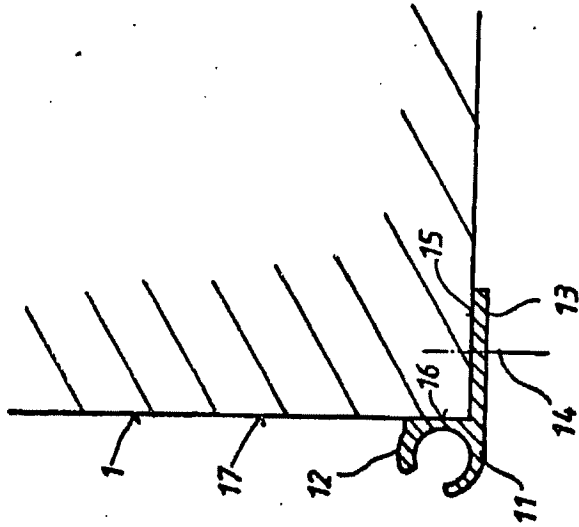

FIG 7

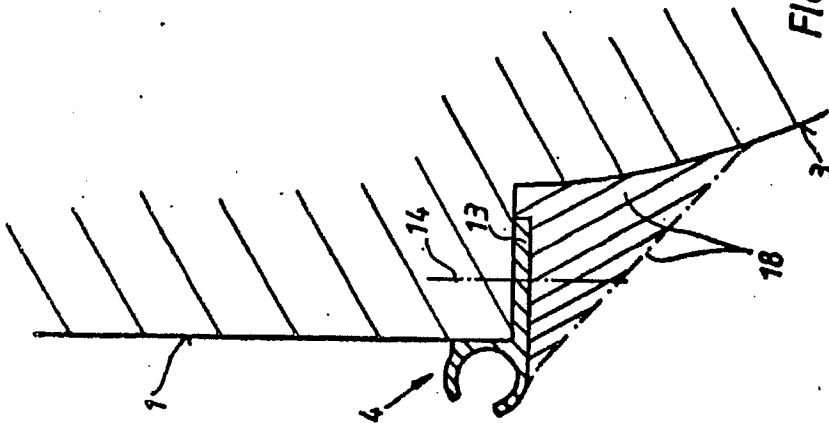

FIG 6