



US007440565B2

(12) **United States Patent**
McLarty et al.

(10) **Patent No.:** **US 7,440,565 B2**
(45) **Date of Patent:** **Oct. 21, 2008**

(54) **CONTACT NUMBER ENCAPSULATION SYSTEM**

(75) Inventors: **Brandon D. McLarty**, Indianapolis, IN (US); **Frederick Wittekind, IV**, Columbus, IN (US)
(73) Assignee: **One Number Corporation**, Anderson, IN (US)

5,904,013 A 5/1999 Greenspan et al.
5,930,700 A 7/1999 Pepper
6,304,649 B1 10/2001 Lauzon et al.
6,438,223 B1 8/2002 Eskafi
6,477,246 B1 11/2002 Dolan
6,563,911 B2 5/2003 Mahoney
6,597,781 B2 7/2003 Schwab et al.
6,631,186 B1 10/2003 Adams
6,687,360 B2 2/2004 Kung

(Continued)

(*) Notice: Subject to any disclaimer, the term of this patent is extended or adjusted under 35 U.S.C. 154(b) by 0 days.

OTHER PUBLICATIONS

(21) Appl. No.: **12/033,042**

Blankenhorn, D., "Voice Activated Dialer for the Mobile Cellular Telephone 3030 (Product Announcement)." Newsbytes, Jan. 17, 1992. File Segment: NW File 649, Gale Group Computer DB (Dialog File 275).

(22) Filed: **Feb. 19, 2008**

(Continued)

(65) **Prior Publication Data**
US 2008/0130861 A1 Jun. 5, 2008

Primary Examiner—Gerald Gauthier
(74) *Attorney, Agent, or Firm*—Krieg DeVault LLP

Related U.S. Application Data

(57) **ABSTRACT**

(63) Continuation of application No. 11/206,689, filed on Aug. 18, 2005.

(51) **Int. Cl.**
H04M 3/46 (2006.01)
(52) **U.S. Cl.** **379/211.02**; 370/352; 379/201.1; 379/207.12; 455/432.1; 707/3; 709/224
(58) **Field of Classification Search** 379/201.1, 379/207.12, 211.02; 370/352; 455/432.1; 707/3; 709/224

A contact number encapsulation system is disclosed that is operable to consolidate a plurality of contact numbers associated with a given user into a single contact number. The system includes a call processing application that uses information contained in a SIP message header to determine a list of contact numbers to call. The SIP message header contains a call destination indication that is used by the call processing application to retrieve the list of contact numbers. The list of contact numbers is user defined and may be updated or modified by an account holder at any given time. Once the list of contact numbers is obtained, a simultaneous call module is used to simultaneously call each number contained in the list. As such, the account holder only needs to provide the primary contact number to individuals desiring to reach him/her instead of various numbers that are associated with various locations the account holder may be located.

See application file for complete search history.

(56) **References Cited**

U.S. PATENT DOCUMENTS

5,166,972 A 11/1992 Smith
5,206,901 A 4/1993 Harlow et al.
5,454,032 A 9/1995 Pinard et al.
5,802,160 A 9/1998 Kugell et al.

18 Claims, 8 Drawing Sheets

Primary Contact Number	Associated Contact Numbers
xxx-xxx-xxxx	Contact Number A
	Contact Number B
	Contact Number C
	Contact Number D
	Contact Number E

U.S. PATENT DOCUMENTS

6,694,004 B1 2/2004 Knoerle et al.
 6,697,478 B1 2/2004 Meldrum
 6,751,216 B2 6/2004 Johnson
 6,778,640 B1 8/2004 Zhang et al.
 6,816,582 B2 11/2004 Levine et al.
 6,898,275 B2 5/2005 Dolan
 6,937,713 B1 8/2005 Kung
 6,940,951 B2 9/2005 Mahoney
 6,954,524 B2 10/2005 Gibson
 6,978,004 B1 12/2005 Levine
 6,993,360 B2 1/2006 Plahte
 7,020,259 B2 3/2006 Hussain
 7,076,045 B2 7/2006 Gibson
 7,088,810 B1 8/2006 Burg
 7,142,644 B2 11/2006 Lockwood
 7,142,646 B2 11/2006 Zafar
 7,143,417 B2 11/2006 Myers
 7,149,506 B2 12/2006 Osterhout
 7,162,236 B2* 1/2007 Dorenbosch et al. 455/432.1
 7,227,940 B2 6/2007 Gibson
 7,254,225 B2 8/2007 Schwab
 2003/0063733 A1 4/2003 Levine et al.
 2003/0123622 A1 7/2003 Gifford
 2004/0003114 A1 1/2004 Adamczyk
 2004/0203664 A1 10/2004 Lei
 2004/0258233 A1 12/2004 Poutschi
 2005/0007999 A1 1/2005 Becker et al.
 2005/0063529 A1 3/2005 Meldrum et al.
 2005/0070286 A1 3/2005 Awasthi
 2005/0123118 A1 6/2005 Terry
 2005/0130631 A1 6/2005 Maguire
 2005/0141490 A1 6/2005 Dolan
 2005/0177622 A1 8/2005 Spielman
 2006/0104431 A1 5/2006 Emery et al.
 2006/0105766 A1 5/2006 Azada
 2006/0126806 A1 6/2006 Trandal et al.
 2006/0153353 A1 7/2006 O'Neil
 2006/0153354 A1 7/2006 Brahm
 2006/0160566 A1 7/2006 Plahte et al.
 2006/0215830 A1 9/2006 Simpson
 2006/0217133 A1 9/2006 Christenson

2006/0218268 A1* 9/2006 Beck et al. 709/224
 2006/0227957 A1 10/2006 Dolan et al.
 2007/0003043 A1 1/2007 Kapur

OTHER PUBLICATIONS

Bradbury, J., "Dial M for Macintosh. (Sophisticated Circuits' Desktop Dialer telephone dialing device for the Macintosh." MacUser, V. 9, N. 3, p. 118(1), Mar. 1993. Gale Group Computer DB (Dialog File 275).
 Business Wire, "iVoice Receives Patent Award for Speech Enables, Automatic Telephone Dialer Using Names, Including Seamless Interface with Computer-Based Address Book Programs," Business Wire, p. 5288, May 28, 2003. Dialog File No. 621 Accession No. 3450671.
 Edge, "Cellular voice recognition: AT&T intros speaker dependent voice dialer technology in cellular market. (AT&T's Voice Activated Dialer for its Mobile Cellular Telephone 3030) (Product Announcement)," Edge, on & about AT&T, v. 7, n181, p. 8(1), Jan. 13, 1992, Gale Group Computer DB (Dialog File 275).
 Levergood T.M., et al, AudioFile: A Network-Transparent System for Distributed Audio Applications (1993). Book., <http://citeseer.ist.psu.edu/28948.html>.
 Lin, S.C., et al. "The development of FAX broadcasting system." System Theory, 1995. Proceedings of the Twenty-Seventh Southeastern Symposium, Pub. Date: Mar. 12-14, 1995, pp. 212-215, INSPEC Accession No. 4917805.
 Lin, S.C., et al. "FAX broadcasting system—The software aspects." Communications, Computers and Signal Processing, 1995. Proceedings, IEEE Pacific Rim Conference. Pub. Date May 17-19, 1995, pp. 554-557, INSPEC Accession No. 5112620.
 PC Week. "Micro Logic PIM upgrade adds phone dialer, network support. (Micro Logic Corp. introduces InfoSelect personal information manager)(product announcement)." PC Week, v. 7, n. 12, p. 24(1), Mar. 26, 1990, Gale Group Computer DB (Dialog File 275).
 Szlam, A., et al, Predictive Dialing Fundamentals; An Overview of Predictive Dialing Technologies, Their Applications, and Usage Today. Paperback, 172 pgs, Pub. Date Jan. 1996. CMP Publications. Business Wire; SpeechSwitch Receives Patent award for TAPI Interface Based, Speech Enables Automatic Telephone Dialer Using Names'; Company Secures Third Speech-Recognition Patent. Page: NA; Aug. 24, 2005.

* cited by examiner

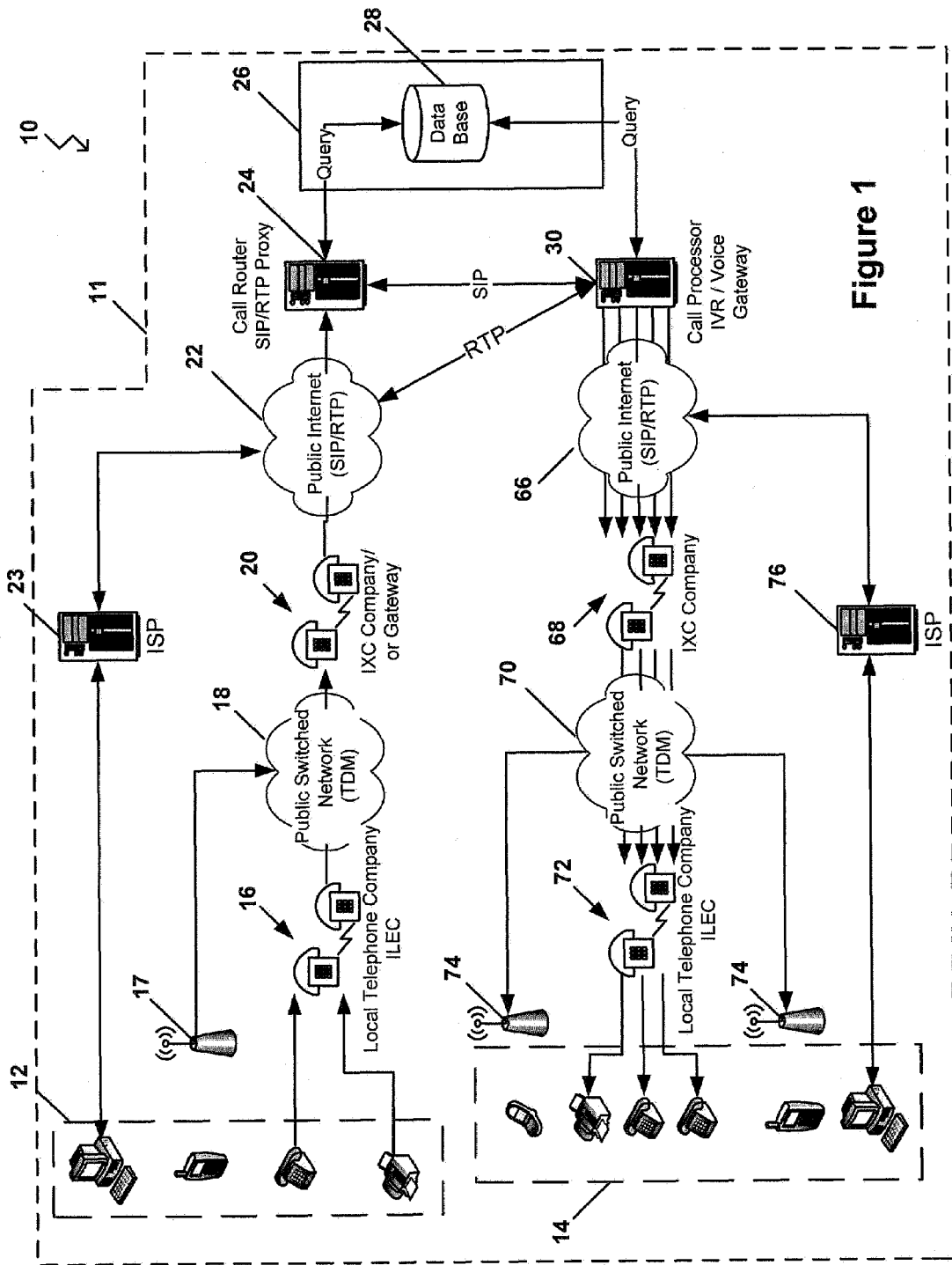

Primary Contact Number	Associated Contact Numbers
xxx-xxx-xxxx	Contact Number A
	Contact Number B
	Contact Number C
	Contact Number D
	Contact Number E

Figure 2

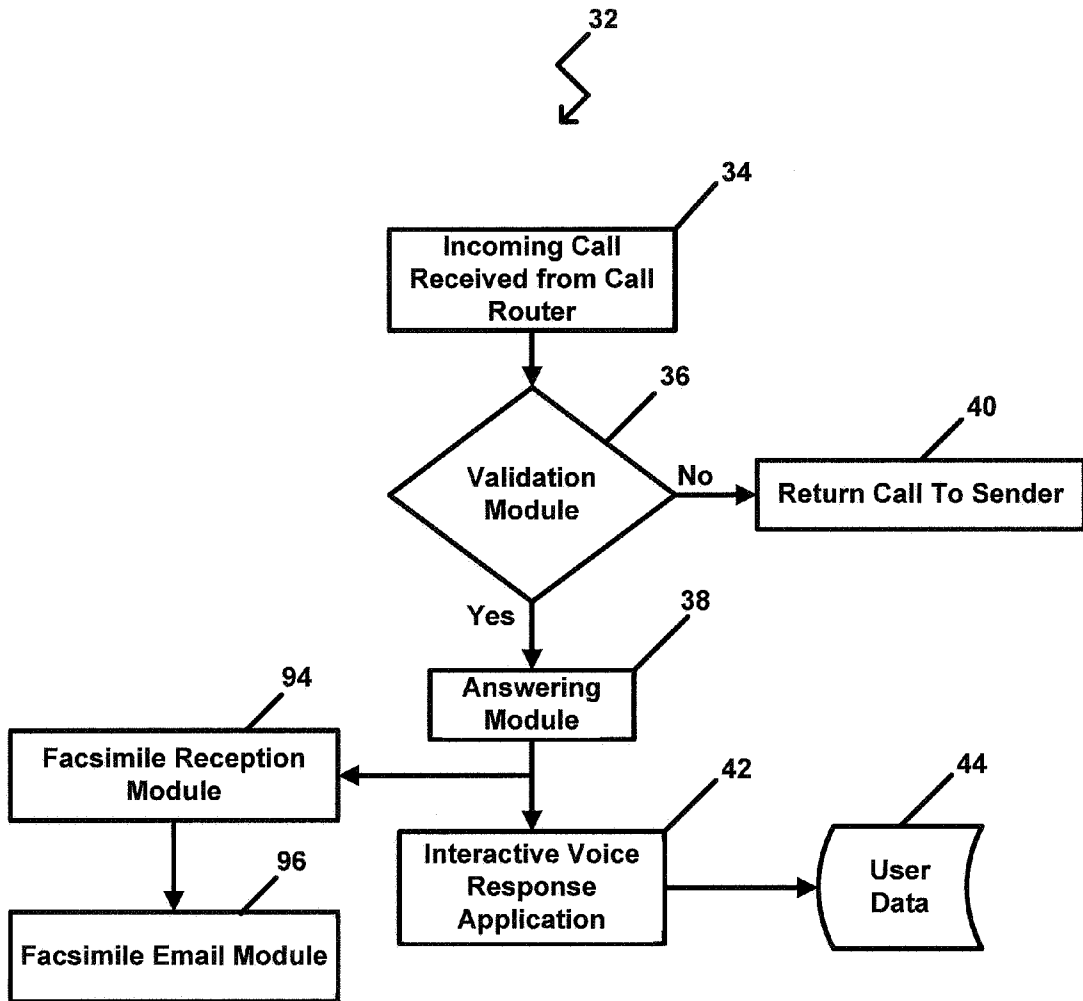

Figure 3

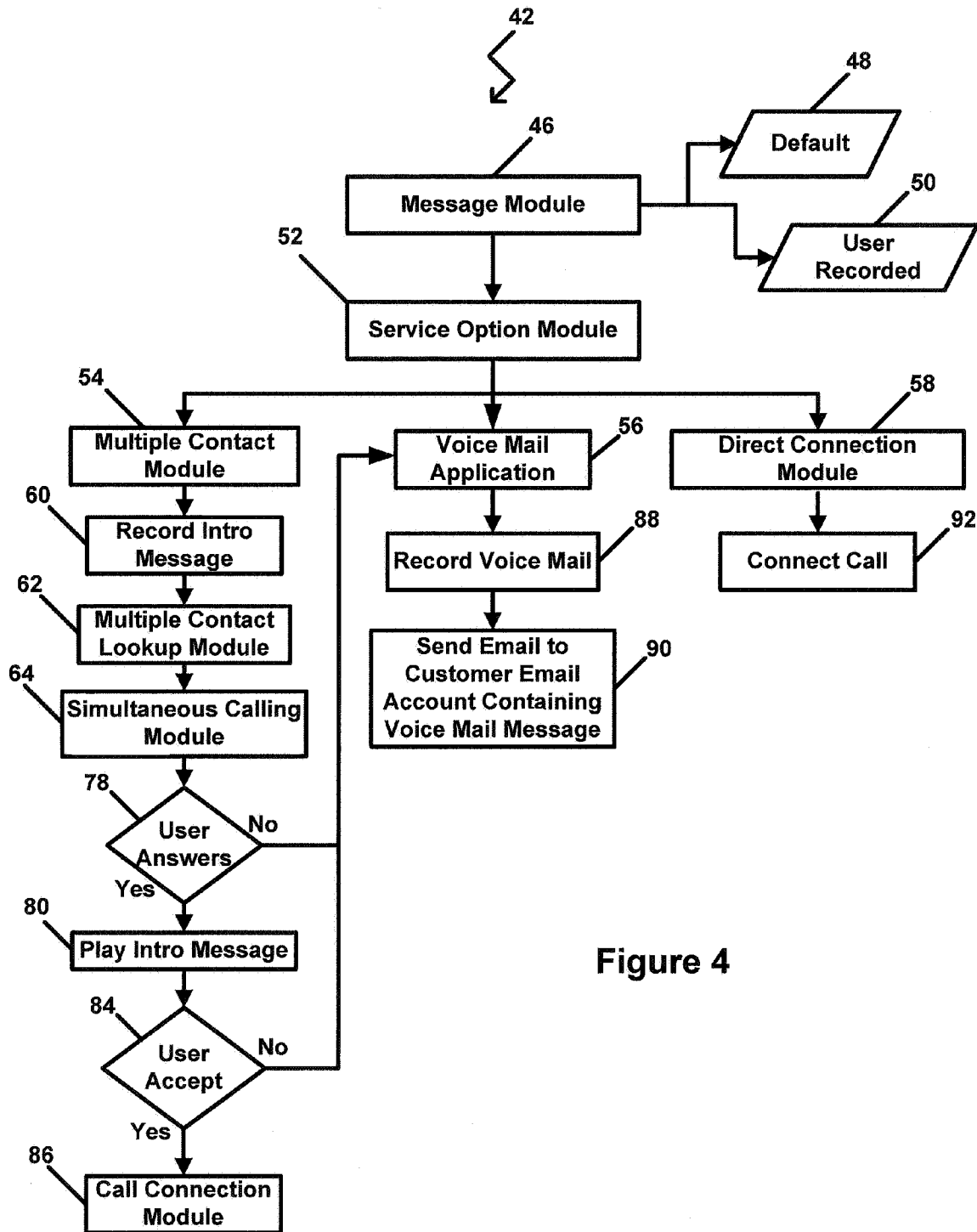

Figure 4

Do you have a cell phone, an office phone, a home office phone, and a fax number? Even if you only have a couple of those numbers do your customers know which one to call to place an order? Do your friends and family know which one to call to invite you to dinner? A one number from 1Num Technologies is the solution. Your customer, friends, and family only need to know your one number to reach you, fax you, or leave you a message. Sign up today and simply everyone's life.

98

Account Login

1Num:

Passcode:

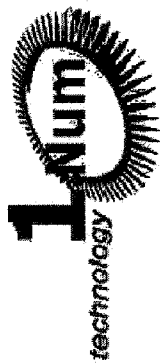

Home Page | 1Num Alert/Residential | 1Num Business | My Account | About Us | 1Num News | Sign Up

Log Out | Balance | Call log | Quick Reference | FAQ's

1Num Account management

3174896140 104

Reach Me #1: 555551212 Enable number: 106

Reach Me #2: 555551213 Enable number:

Reach Me #3: 555551214 Enable number:

Reach Me #4: Enable number:

Reach Me #5: Enable number: 108

Personal Operator: 555551000

This is the number that your caller will be live transferred to if they press "0" on the original greeting. If you enable this feature you may want to let your callers know of the option in your main greeting such as "Press zero to speak to the receptionist".

Availability Status: Unavailable 112 Available 114

Calling ID: Show Calling Party's Caller ID 118 Show 1Num Caller ID 120

Disable Call Screening: Activate Call Screening 124

1Num Passcode reset: Check box to change passcode. 126

Please enter only numbers between 1000, and 999999 in the table fields below. This will be your new web portal and voice portal passcode associated with this 1Num.

Passcode:

Verify:

Email voice messages to:

Figure 5

132



134

>Home page 1Num Alert 1Num Business My Account About us 1Num news Sign Up

Log In Contact Us FAQ's Terms of Service

Welcome to 1Num
 You have successfully signed up for 1Num service.
 Your account is set up service will be enabled to receive calls and record your greetings at the top of the hour. In the meantime, please log into your Voice Portal with the information below to set up your Reach Me numbers.
 Account Number: 01000300
 1 Number: 3184503166
 Passcode: 1234
 Please log in to you 1Num Total Control web portal. [Click here.](#)

To set up your account you will want to set Reach Me numbers and record a personal greeting.

Navigating your total control voice portal:

While your main greeting is playing press "*" then enter your voice portal password followed by the "#".

1. Enter your into your 1Num voice mail box.
4. Change your "Reach Me" numbers.
 (All 5 of your follow me numbers will ring simultaneously.)
 - Change Reach Me 1.
 - Change Reach Me 2.
 - Change Reach Me 3.
 - Change Reach Me 4.
 - Change Reach Me 5.
6. Change "Availability status"
 - Unavailable 1Num calls will ring your numbers.
 - Unavailable 1 Num calls will be sent directly to your voice mail.
7. Turn off email delivery of voice mail.
 - 9. Turn email delivery off. (can only be turned back on thru the 1Num web portal.)
8. Change "Receptionist Number" enter the 10 digit number your 1Num will deliver your caller to if J is pressed.
9. Change recorded messages/greetings
 - Change "main greeting" - what a caller hears when they dial your 1Num.
 - Change the "Announcement Request" -
 - Change the "call announce recording" - When you pick up your 1 1Num you will hear "this call is for" ...
 - 4. Change the "Unavailable greeting" - what callers will hear when being sent to voice mail.

136

138

140

142

144

146

Figure 6

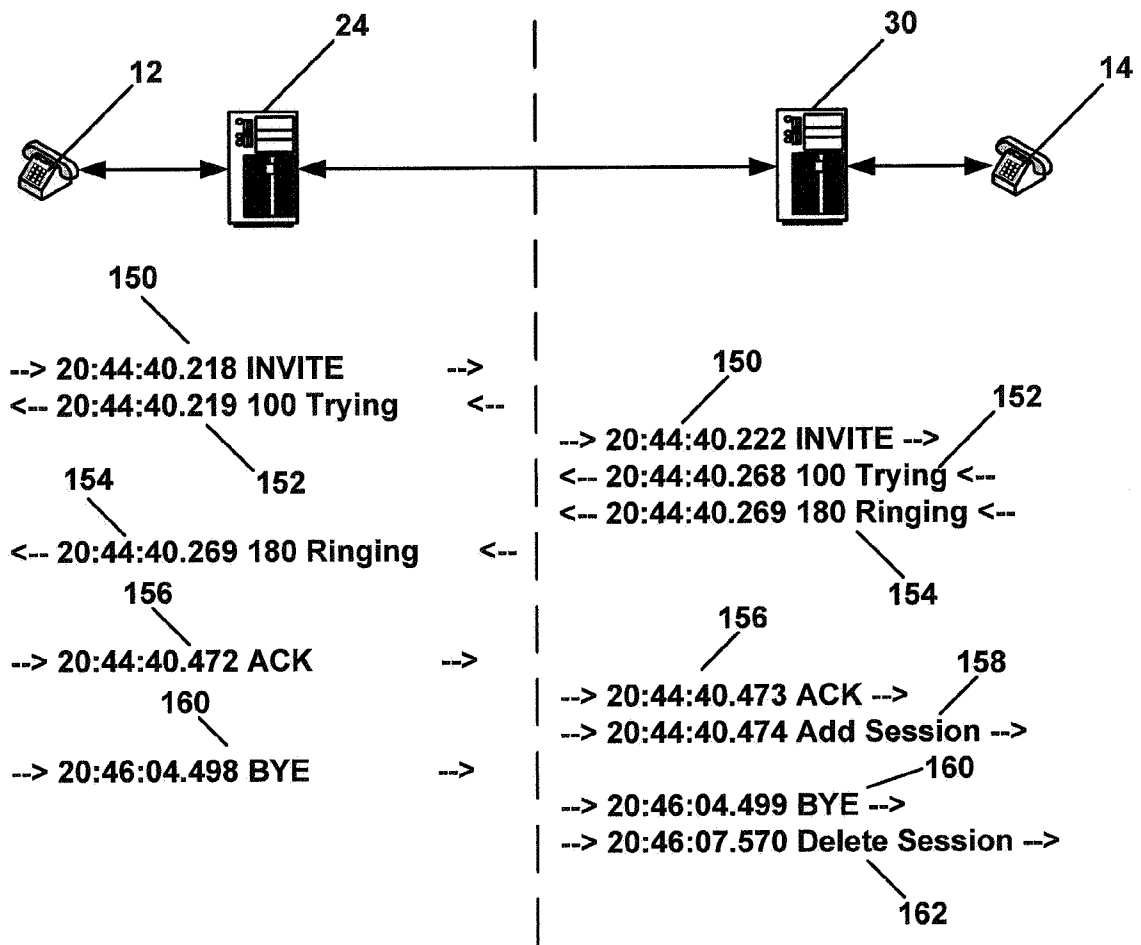

Figure 7a

SIP Message Header

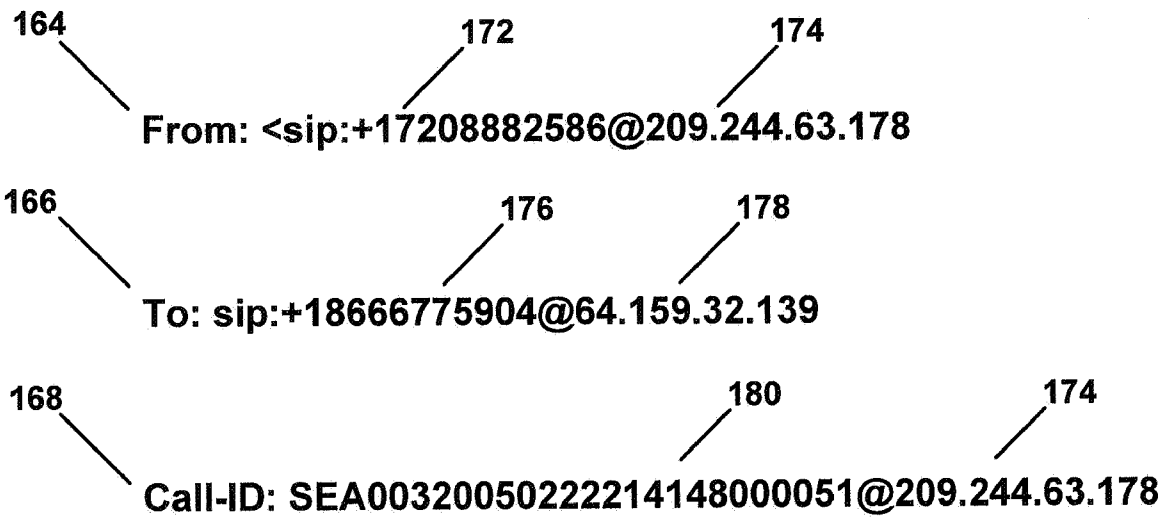

Figure 7b

CONTACT NUMBER ENCAPSULATION SYSTEM

CROSS REFERENCE TO RELATED APPLICATION

The present application is a continuation application of and claims the benefit of U.S. application Ser. No. 11/206,689 entitled "Contact Number Encapsulation System" filed on Aug. 18, 2005, which is hereby incorporated by reference in its entirety.

BACKGROUND OF THE INVENTION

1. Technical Field

The present invention relates generally to communication systems and more particularly, to a method and system for allowing telephone users to cause multiple phone lines to ring when a calling party dials a single primary contact number thereby eliminating the need for providing multiple contact numbers to third parties.

2. Related Art

The history of modern-day communications technology can be said to have started when Samuel Morse invented the wire line telegraph in 1832. However, it was Alexander Graham Bell's invention of the telephone, in 1874, that led to the development of our present day communications technology. Morse had simply created a way for humans to extend their ability to transfer information—instantly—over great distances. Bell gave us the ability to have the most intimate form of communication over distances—the use of our voices. As readily apparent, the invention of the telephone has dramatically changed the manner in which people communicate with one another and most people have telephones located at various access points or locations at any given time and are responsible for knowing or having access to various contact numbers associated with them.

The concept of the telephone instrument, as well as the system that allows it to work, was initially so strong that most communication technology developed during the past 125 years supports an efficient voice communication network. It wasn't until 2004 that major telecommunication carriers announced the need to develop, and support, a network designed for the purpose of transporting digital data. From 1874 to 1980, communication networks around the world were constructed to facilitate the efficient and economical transmission of voice conversations. Multiplexing and digital transmission systems were developed to "cram" more voice conversations into the existing copper wire communication facilities.

The Internet, first developed in 1973 as a project for the U.S. Department of Defense Advanced Research Projects Agency (ARPA), initiated a profound change in the future development of communication networks and technologies. Originally called the Arpanet, linking several Universities and research laboratories, it evolved into the world wide web ("WWW"). During this period, there were a number of significant technology advances and government enforced corporate reorganizations that helped to change the direction of communication systems development. Computing and communications technologies were provided a big boost by the invention of the integrated circuit (IC) in 1959. The IC permitted development and manufacture of smaller and more automated communication devices at a very low cost. The Carterphone Decision, by the U.S. Supreme Court, in 1968, made it possible for the connection of non-telephone company owned devices (until this point, only devices owned and

operated by the telephone companies were permitted). In the 1970s, fiber strands were first used as a communication medium. In 1983, the U.S. Supreme Court mandated reorganization of AT&T was enforced.

New inventions coupled with increasing business and consumer demand for computer and data communication services forced a change in, the nature of the development of communications networks. By 1995, most installation of communications networks was devoted to the efficient transmission of data generated by computers. However, these networks were still based on a voice communication design. The development and introduction of broadband data communications standards ("IEEE 802 Series") helped to create a demand for communication networks designed to support data communications. By 2003, wireless (cellular telephone) networks were available to almost every location of the United States (remote wilderness areas still lack coverage). According to the Cellular Telecommunications & Internet Association (CTIA), in 2003 there were more than 148 million wireless subscribers, and 92% were using digital service.

As communication technology continues to move forward and various types of devices become available that are capable of allowing people to communicate with one another, the amount of contact numbers associated with individuals will continue to grow dramatically. It is not uncommon for any given person to have four or five different contact numbers associated with them at any given time. For example, it is not uncommon for a single person to have a home phone number, a work phone number, a wireless terminal phone number, and a facsimile number. As a result, it is increasingly difficult to get in contact with any given individual because the calling party may not know exactly where the person they are trying to reach is located. Further, the calling party may only know one phone number for the individual they are trying to reach.

As a result of the aforementioned problems, a need exists for a communication encapsulation system that will work in conjunction with a wide variety of communication devices and systems to allow a single person to have one primary contact number instead of multiple contact numbers.

SUMMARY OF THE INVENTION

A contact number encapsulation system is disclosed that allows an account holder to be assigned a primary contact number for use in connection with conducting voice-based communication. Although the primary contact number is preferentially for use in voice communication, the contact number encapsulation system may also be capable of receiving incoming facsimiles as well. The primary contact number may be a custom telephone number that is assigned to a user at the time of account setup or it may be a telephone number that is transferred from a previous service provider at the time of account setup. The contact number encapsulation system allows people desiring to contact the owner of the primary contact number to use one number to reach the owner at various locations instead of the contact number that may be assigned to the owner at each respective location. Dialing the primary contact number will cause a plurality of user designated contact numbers to ring at the same time, thereby allowing individuals to only have one telephone number associated with them instead of multiple contact numbers for various locations.

The contact number encapsulation system may include a calling terminal that a caller may use to attempt to reach the owner of the primary contact number. Once the primary contact number is dialed by the calling terminal, the call may be

routed to a call router through the assistance of various different types of communication networks depending on what network the calling terminal is connected with at the time of making the call. The call router is operable to route the call to a predetermined destination. The primary contact number may be contained in a list in a database associated or connected with the call router that associates the primary contact number with a call processor server. The call router may use a lookup module to determine an IP address the call should be routed to by the call router, which in the present invention, corresponds to the call processor server.

The call processor server may include a validation module that determines if the primary contact number that is associated with the incoming call is a valid primary contact number. If the call designates a valid contact number, an answering module may answer the incoming call thereby establishing a communication session between the calling terminal and the call processor server. If the incoming call is a facsimile, the answering module will forward the call to a facsimile module that is operable to receive the incoming facsimile images and then forward them to a user designated email address as an attachment. If the incoming call is a voice call, the answering module may forward the call to an interactive voice response application.

The interactive voice response application may include a message module that plays a short introductory message recorded by the owner of the primary contact number or a default computer generated message. A service option module may then be used to present the calling party with various contact options (e.g.—“Press 1 to contact Jane Doe”, “Press 2 to leave a message for Jane Doe” and so forth). If the user selects the option associated with contacting the owner of the primary contact number (e.g.—by pressing 1 on the calling terminal), a multiple contact module may prompt the user to record a short introductory message (e.g.—“Please state your name”). The multiple contact module may store the message and then use a multiple contact lookup module to generate a list of contact numbers associated with the owner of the primary contact number.

The owner of the primary contact number may provide with at least two options to manage his/her account. The first option is a web-enabled control panel that allows the owner to enter contact numbers to be associated with the primary contact number. As such, once the owner logs into his/her account, they are provided with a control panel that allows them to enter the telephone numbers they want contacted if the primary contact number is dialed. The second option is a voice portal menu-based option, which allows the owner to call the primary contact number, enter designated access codes, and gain access to his/her account. The owner may then be provided with a menu of options that allows the owner to enter, edit, or delete contact numbers from their respective contact number list.

Once the list of contact numbers associated with the primary contact number is obtained or generated, a simultaneous calling module may be used to setup a plurality of calling sessions with all of the terminals associated with the numbers contained in the contact list. As such, the simultaneous calling module simultaneously calls every number in the contact list to attempt to reach the owner of the primary contact number. If the owner of the primary contact number answers one of the terminals, a media session may be established between the call reception terminal and the call processor server. The multiple contact module may then play the short introductory message recorded by the caller to the owner and prompt the owner to either accept the call or send the call to voice mail. If the owner accepts the call, a voice based media session is

established between the calling terminal and the call reception terminal. If the owner declines to accept the call, the calling party may then be directed to a voice mail application by the multiple contact module.

The contact number encapsulation system allows individuals to have one contact number associated with them instead of a plurality of contact numbers. Multiple contact numbers are difficult to remember, time consuming to locate, and time consuming to call each location that the party may be in an attempt to locate them. The present invention provides a method of allowing individuals to only have one contact number associated with them while at the same time allowing them to be reached at various locations in which they may have different contact numbers. The contact number encapsulation system is operable to simultaneously dial every user designated contact number that may be associated with the account owner when the primary contact number of the owner is dialed.

Other systems, methods, features and advantages of the invention will be, or will become apparent to one with skill in the art upon examination of the following figures and detailed description. It is intended that all such additional systems, methods, features and advantages be included within this description, be within the scope of the invention, and be protected by the following claims.

BRIEF DESCRIPTION OF THE DRAWINGS

The components in the figures are not necessarily to scale, emphasis instead being placed upon illustrating the principles of the invention. Moreover, in the figures, like reference numerals designate corresponding parts throughout the different views.

FIG. 1 represents an illustrative communication network in which an embodiment of the present invention may operate.

FIG. 2 is a table illustrating the association between a primary contact number and a plurality of other contact numbers associated with a given account holder.

FIG. 3 is a flow chart for a call processing application.

FIG. 4 is a flow chart for an interactive voice response application.

FIG. 5 represents an illustrative user account management interface that allows an account holder to modify their user account attributes and/or settings.

FIG. 6 represents an illustrative menu setup for a user account voice control portal.

FIG. 7a illustrates representative SIP commands or methods used by the contact number encapsulation system to establish a session between a calling terminal and a call receiving terminal.

FIG. 7b illustrates representative SIP message header information used by the contact number encapsulation system to call a plurality of call receiving terminals.

DETAILED DESCRIPTION OF THE PRESENTLY PREFERRED EMBODIMENTS

Referring to FIG. 1, a logical network flow in which a contact number encapsulation system 10 may function is illustrated. The contact number encapsulation system 10 allows a caller, with the assistance of a calling terminal 12, to place voice calls, send faxes, and send text messages to a call reception terminal 14 over a communication network 11. The calling terminal 12 or the call reception terminal 14 may be a wireless terminal, a wired terminal or phone, a facsimile terminal, an Internet based terminal using voice-over IP (“VoIP”) technology or any one of a variety of other types of

communication devices. For the purpose of the present invention, it is important to note that the communication network **11** is operable to allow communication, preferentially voice-based communication, to be conducted between the calling terminal **12** and the call reception terminal **14**. This is accomplished by establishing a communication path or link between the respective terminals **12**, **14** being used by the parties to communicate.

The communication network **11** may include an incumbent local exchange carrier (“ILEC”), a competitive local exchange carrier (“CLEC”), a regional bell operating company (“RBOC”) **16** that is connected with the calling terminal **12**. In the alternative, the calling terminal **12** may be a wireless terminal, in which case the calling terminal may be connected with a wireless communication system **17**. The calling terminal **12** may connect to the communication network **11** through the use of a wireless terminal, a traditional wired terminal or phone, a facsimile terminal, or through the use of an Internet based terminal using voice-over IP (“VoIP”) technology. The ILEC **16** may be connected with a PSTN **18**. The PSTN **18** may be connected with an inter-exchange carrier (“IXC”) **20** that is capable of providing interstate (i.e.—long distance) communications services within the U.S.

The IXC **20** may be connected with an Internet portal **22**. The Internet portal **22** may rely on different types of communication protocols that allow communication to be conducted over the communication network **11**. The Internet portal **22** may use session initiation protocol (“SIP”) to communicate or transport data as well as to initiate various types of actions to be taken over portions of the communication network **11**. SIP is an IP telephony signaling protocol developed by the Internet Engineering Task Force (“IETF”). It is primarily used for VoIP calls, however, SIP can also be used for video or any media type. SIP may also be used in conjunction with the instant messaging and presence leveraging extensions (“SIMPLE”) for instant messaging.

SIP is a text-based protocol that is based on HTTP and MIME, thereby making it suitable and very flexible for integrated voice-data applications. SIP is a signaling protocol used for establishing sessions in an IP network. SIP is designed for real-time transmission, uses fewer resources and is considerably less complex than H.323. Its addressing scheme uses universal resources locators (“URLs”) and is human readable; for example: sip:xyz@entity.com. SIP relies on the session description protocol (“SDP”) for session description and the real-time transport protocol (“RTP”) for actual data transport. In the present invention, once the session is established, RTP may be used to transmit the media (e.g.—audio) between the calling terminal **12** and the call reception terminal **14**.

SDP is an IETF protocol that defines a text-based message format for describing a multimedia session. Data such as version number, contact information, broadcast times and audio and video encoding types are included in the message. RTP is an IP protocol that supports real-time transmission of voice and video data streams. It is widely used for IP telephony and audio and video streaming. An RTP packet rides on top of UDP, the counterpart of TCP, and includes time-stamping and synchronization information in its header for proper reassembly at the receiving end. For example, as illustrated in FIG. **1**, the contact number encapsulation system **10** may use RTP to transmit audio or video data between the calling terminal **12** and the contact terminals **14** via the call processor server **30**.

The Internet portal **22** may be connected with a call router or proxy server **24**, which is a network device that forwards data packets from one network to another. Based on internal

routing tables, routers read each incoming packet and decide how to forward it. To which interface on the router outgoing packets are sent may be determined by any combination of source and destination address as well as current traffic conditions (load, line costs, bad lines, etc.). In the present invention, the call router **24** may be used to route or direct a call (i.e.—packets of data) being made by the calling terminal **12** to the appropriate or designated call reception terminal **14**. The Internet portal **22** may also be connected with an Internet service provider (“ISP”) **23** that allows various types of calling terminals **12** (e.g.—personal computers, VoIP terminals) to communicate over the communication network **11**.

As set forth in greater detail below, once the call and its associated data reach the call router **24**, the call router **24** may include a routing module **26** that determines where the call should be directed or routed. To determine where the call should be routed, the routing module **26** may query a routing database **28**. The routing database **28** may contain a routing table that includes a destination address that is dependent on information contained in the call’s SIP message header. In the present invention, the information or data contained in the call’s SIP message header causes the call router **24** to forward the call to a call processor gateway server **26**. The data in the call’s SIP message header that the routing module **26** may use corresponds to a primary contact or telephone number that the caller dialed when placing the call from the calling terminal **12**. The primary contact number that the calling terminal **12** dials causes the call router **24** to forward the call to the call processor gateway server **26** which then further processes the call.

Referring to FIG. **2**, the primary contact number may be a user specific telephone number that is assigned to a respective user account at the time the account is setup by the contact number encapsulation system **10**. In the alternative, the primary contact number may be transported to the contact number encapsulation system **10** from another carrier via Local Number Portability (“LNP”). As set forth in greater detail below, the owner of the primary contact number may designate a list of contact numbers to be associated with the primary contact number. The right-hand column of the table illustrated in FIG. **2** contains a list of contact numbers that may be associated with the primary contact number listed in the left-hand column. When a caller dials the primary contact number in an attempt to reach the account owner, the contact number encapsulation system **10** retrieves the list of associated contact numbers set forth in FIG. **2** and simultaneously calls all of the contact numbers contained in the list.

Referring to FIG. **3**, the call processor gateway server **30** may include a call processing application **32**. The call processing application **32** may receive a call at step **34** from the call router **24** that designates a primary contact number. Once received, the call processing application **32** may include a validation module **36** that determines if the call is a valid primary contact number for the call processor gateway server **26**. If the call identifies an invalid primary contact number or a number not associated with the service being provided, the validation module **36** may return the call to the sender at step **40**. If the call identifies a valid primary contact number, an answering module **38** may answer the call. The answering module **38** may forward the call to an interactive voice response application **42**. The interactive voice response application **42** may access a user database **44** that may contain user preferences and voice recordings to further handle the call, as set forth in greater detail below.

Referring to FIG. **4**, the interactive voice response application **42** may include a message module **46**. The message module **46** may access a default message **48** or a user recorded

message 50 that may be stored in the user database 44. When the call is answered by the answering module 38, the answering module 38 may answer the call and forward it directly to the interactive voice response application 42. The message module 46 may access an account associated with the primary contact number to retrieve either the default message 48 or the user recorded message 50. The message module 46 may use the call receiver's primary contact number as an identifier to lookup the respective message to play. By way of example only, the default message 48 may consist of a computer generated greeting and the user recorded message 50 may consist of a short recording made by the owner of the primary contact number.

After the initial message or greeting is played by the message module 46, the call may be passed or directed to a service option module 52. The service option module 52 may provide a user of the calling terminal 12 with a plurality of options. In an illustrative embodiment of the present invention, the service option module 52 may include a multiple contact module 54, a voice mail application 56, and a direct transfer module 58. The multiple contact module 54 may prompt the caller to record a short introduction message, such as the name of the caller, which is illustrated at step 60. The multiple contact module 54 may then use a multiple contact lookup module 62 to retrieve a list of contact numbers associated with the primary contact number from the user database 44. As set forth in greater detail below, users of the present invention are allowed to store, modify and edit a plurality of terminal contact numbers that are associated with the primary contact number that may be stored in the user database 44.

The multiple contact lookup module 62 may then pass the retrieved list of contact numbers to a calling module 64 that is operational to simultaneously call all of the contact numbers contained in the list of contact numbers. In other words, the calling module 64 simultaneously dials all of the contact numbers associated with the primary contact number at the same time so that all of the call reception terminals 14 associated with the call receiver ring or are called at the same time. This allows the call receiver, who may have numerous telephone numbers, to give out and use one contact number (i.e.—the primary contact number) to be reached at various locations instead of using individual numbers for each respective location.

As illustrated in FIG. 1, the call processor server 30 may be connected with a second Internet portal 66, which in turn may be connected with a second IXC 68. The second IXC 68 may be connected with a second PSTN 70, which in turn may be connected with a second ILEC, CLEC, or RBOC 72 or a second wireless access system 74. A second ISP 76 may also be connected with the second Internet portal 66 that is operable to allow various types of call reception terminals 14 (e.g.—computer terminals, VoIP terminals) to communicate over the communication network 11.

As set forth above, the communication network 11 supports various types of communication, preferentially voice communication, to be conducted between the calling terminal 12 and a receptive call reception terminal 14 through the use of the primary contact number. As clearly illustrated, there may be several network paths or communication links that exist between the calling terminal 12 and the call reception terminal 14. Those skilled in the art would recognize that the communication network 11 illustrated in FIG. 1 should be viewed in an illustrative sense at that other components and other types of network paths could exist that are capable of establishing a communication link between calling terminals 12 and call reception terminals 14.

Referring once again to FIG. 4, the calling module 64 calls all of the call reception terminals 14 associated with the primary contact number being dialed by the calling terminal 12. At step 78, if the call receiver answers the call on a respective call reception terminal 14, the short introduction message recorded by the caller may be played back to the call receiver, which is represented at step 80. If the call receiver does not answer the call, at step 78 the call may be sent to a voice mail application 56 after a predetermined period of time or number of rings.

After the short introduction message is played to the call receiver at step 80, the call receiver may be prompted to accept or decline the call, which is represented at step 84. If the call receiver accepts the call, the call is then connected to the associated call reception terminal 14 by a call connection module 86. The call connection module 86 establishes a communication link or talk path between the calling terminal 12 and the respective call reception terminal 14 that the call receiver answers. If the call receiver declines to answer the call, the call may be sent to the voice mail application 56. As clearly set forth in the description above, the contact number encapsulation system 10 allows a user to associate a plurality of contact numbers with a single primary contact number, thereby reducing the amount of phone numbers people have to remember in order to communicate with the user. The user only needs to give out a single contact number to contacts instead of having to provide multiple numbers to others so that individuals can communicate with the user at various locations.

As set forth above, when the caller enters the service option module 52, one of the options that the caller may be presented is to directly enter voice mail of the call receiver instead of attempting to reach the call receiver. If the caller selects to leave a voice mail or is sent to the voice mail application 56 in the event the call receiver does not answer, the voice mail application 56 may prompt the caller to leave a voice mail and may record the voice mail, which is represented at step 88. Although not illustrated, the voice mail message may be stored in a voice mail database and may be stored such that it is associated with the call receiver (i.e.—the primary contact number). A voice mail email module 90 may be used to automatically send an email to a designated email account of the call receiver that contains the voice mail message as a file attachment in a designated file format.

The interactive voice response application 42 may also include a direct connection module 58 that may allow the call receiver to designate a predetermined contact number to be called if a caller dials the primary contact number. The direct connection module 58 allows the call receiver to designate a predetermined contact number to be used instead of the list of contact numbers used by the calling module 64. For example, the call receiver may be on vacation and may want to use a vacation contact number instead of the list of contact numbers that are called by the calling module 64.

Referring back to FIG. 3, the answering module 38 may also be operable to forward an incoming call to a facsimile module 94. If the answering module 38 detects a facsimile signal when the incoming call is answered, the answering module 38 automatically switches into facsimile reception mode and receives the incoming facsimile message through the facsimile module 94. After the facsimile is received, a facsimile email module 96 may convert the facsimile into a predetermined file format and send the file to a call receiver's designated email account. The call receiver may then view the facsimile by accessing an email application and opening up the attachment in a designated viewer.

As illustrated in FIG. 5, the contact number encapsulation system 10 may also include a web-enabled user account interface 98 that allows an account holder to modify the account attributes associated with their respective primary contact number, which is illustrated in FIG. 5 at 100. The account holder may access the user account interface 98 by logging into their account via the Internet using a web-enabled terminal 14. For instance, the account holder may use a terminal 14 to access their account through ISP 76. The user account interface 98 functions as a control panel where the account holder may select and change various options and settings.

A comprehensive contact number list 102 may be included that allows the account holder to designate all of the contact numbers they want called when the primary contact number 100 receives an incoming data message (e.g.—telephone call, etc.). The comprehensive contact number list 102 may include a plurality of contact number entry fields 104 that allow a user to enter designated contact numbers that they want the calling module 64 to contact or call if the primary contact number 100 is contacted or dialed. The comprehensive contact number list 102 may be stored in the user database 44 and may be capable of being accessed by the call processor server 30. A plurality of contact number enablement fields 106 may also be included that allow a user to turn on or off respective contact numbers contained in the comprehensive contact number list 102.

The user account interface 98 may also include a personal operator designation field 108. The interactive voice response application 42 may also include an operator option that allows the account holder to designate an operator number that is called if, for example, a predetermined data input is entered by the caller once the answering module 38 answers the incoming call (e.g.—the caller presses “0” on a keypad of the terminal 12). For example, the account holder may have a personal assistant and if “0” is pressed by the caller, the call may then be routed to a contact number of the account holder’s personal assistant. The direct transfer module 58 may be used to forward the call to a contact number entered in the personal operator designation field 108.

A user availability status field 110 may also be included that allows the account holder to indicate whether or not they are available to receive calls. If the account holder selects an unavailable option 112, the answering module 38 may automatically forward the call to the voice mail application 56. If the user selects an available option 114, the answering module 38 may forward the call to the interactive voice response application 42 or the multiple contact module 54. A caller identification control field 116 may also be included that allows the account holder to turn on and off caller identification functions. An incoming caller identification option 118 allows the account holder to enable the display of the contact number of the calling terminal 12 on the call receiving terminal 14. A primary contact number option 120 may cause the calling module 64 to display the primary contact number of the account holder on the call receiving terminal 14 instead of the contact number of the calling terminal 12.

A call screening designation field 122 may be included that allows the account holder to enable or disable the portion of the multiple contact module 54 that prompts the caller to record a short introduction message. A screen activation option 124 and a screen deactivation option 126 may be selected to turn this feature on and off. A passcode reset field 128 may be included that allows the account holder to change their respective access passcode. This passcode may be used to access voicemail or change settings associated with the primary contact number through the use of various types of remote terminals 14 (e.g.—wired telephones, wireless termi-

nals, etc.) that may not have Internet access or be web-enabled. An email address designation field 130 may also be included that allows the account holder to designate the email address to which all voice mail messages and facsimiles may be forwarded. A store entry option 132 may be included that causes the settings or changes made by the account holder in the user account interface 98 to be stored in the user database 44 that contains account data about respective account holders assigned a primary contact number.

Referring to FIG. 6, the call receiving terminals 14 may also have access to a service portal application 134 that may be accessed by dialing the primary contact number and pressing a predetermined key on a keypad of the terminal 14 (e.g.—by pressing the “*” key). The service portal application 134 allows account holders to modify settings or properties associated with their respective account through the use of terminals 14 that may not have Internet access by contacting the primary contact number. As set forth above, the account holder may use keys on a keypad associated with the terminal 14 to navigate a menu based interactive system.

As illustrated in FIG. 6, the service portal application 134 may include various options such as an enter voice mail option 136, a change assigned contact numbers option 138, an availability designation option 140, a turn off email delivery of voice mail option 142, a change personal operator number option 144, and a change recorded messages/greetings option 146. All of the options and their respective functionality should be readily apparent based on the detailed description of the embodiments set forth above and as such, they will not be repeated. Once all of the changes are entered, when the user disconnects or hangs up, the changes may be stored in the user database 44.

Referring to FIGS. 1 and 7a, the contact number encapsulation system 10 is operable to establish a session between a calling terminal 12 and a call reception terminal 14 using SIP commands or methods. FIG. 7a represents a few illustrative SIP commands that may be used to establish the session between the calling terminal 12 and the call reception terminal 14. To initiate a session, the call router 24 may receive, or may generate in response to an incoming call from the calling terminal 12, an INVITE command 150 that is sent over the communication network 10. The INVITE command 150 may be generated in response to a user of the calling terminal 12 dialing a primary contact number associated with a given user. The INVITE command 150 indicates that the user associated with the primary contact number is being invited to participate in the session.

The call router 24 may forward the INVITE command 150 to the call processor server 30. As set forth in detail below, the call router 24 uses a lookup routine to determine the IP address of the call processor server 30. An SIP informational response 152 may be generated by the call processor server 30 that may be sent to the call router 24. The SIP informational response 152 may indicate that the call processor server 30 is attempting or trying to add the session. A second SIP informational response 154, which may also be passed to the call router 24, may be generated by the call processor server 30 that indicates that the call processor server 30 is ringing the call reception terminal 14.

An acknowledge (“ACK”) command 156 may be generated by the call router 24 to confirm that the call router 24 has received a final response from the call processor server 30 to the INVITE command 150. The ACK command 156 is sent to the call processor server 30. Once the ACK command 156 is received, an add session command 158 may be generated by the call processor server 30 that adds the session. At this point, the session between the calling terminal 12 and the call recep-

11

tion terminal **14** is established and RTP may be used to directly transmit media content between the respective terminals **12**, **14**. Once the session is over, a termination (“BYE”) command **160** may be generated by either the call router **24** or the call processor server **30** that indicates that the session should be terminated. A delete session command **162** may then be generated by the call processor server **30** that deletes the session.

Referring to FIGS. **1** and **7b**, as previously set forth, the SIP message header that the call processor **30** receives may contain various data fields and SIP commands. The SIP message header may contain an origination field **164**, a destination field **166**, and a caller identification field **168**. The origination field **164** may include a caller number field **172** and a caller IP address field **174**. The caller number field **172** corresponds to the telephone number that is assigned to the calling terminal **12**. The caller IP address field **174** corresponds to the IP address that the call processor server **30** should route data associated with the call, which typically corresponds to the call router **24**.

The destination field **166** may include a primary contact number field **176** and a primary contact IP address field **178**. The calling terminal **12** provides the information or data contained in the primary contact field **176** when a user dials a primary contact number. When the calling terminal **12** makes a call or attempts to establish a session by dialing a primary contact number, the call router **24** may obtain the primary contact IP address field **178** associated with the primary contact number from the database **28**. The primary contact IP address field **178** corresponds to the IP address of the call processing server **30**. As such, the call router **24** and the call processor server **30** are able to obtain IP addresses for one another so that data can be directed to the appropriate destinations. The caller identification field **168** is a unique field that is used to identify a call. A router gateway machine identification field **180** may be included to designate a particular call router **24** in case more than one call router **24** is associated with a given caller IP address field **174**.

As previously set forth, the call processing application **32** uses the information contained in the SIP message header to lookup and simultaneously ring a plurality of contact numbers that are associated with the primary contact number. The simultaneous calling module **64** creates a session between each call reception terminal **14** associated with the primary contact number. Once a user answers one of the respective terminals **14**, media (e.g.—the audio portion of the phone call) may be transmitted between the terminals **12**, **14** using RTP. In the preferred embodiment, the media is transmitted directly from the call processor server **30** to the Internet portal **22** and avoids the call router **24**.

While the present invention has been described with reference to specific exemplary embodiments, it will be evident that various modifications and changes may be made to these embodiments without departing from the broader spirit and scope of the invention as set forth in the claims. Accordingly, the specification and drawings are to be regarded in an illustrative rather than a restrictive sense.

What is claimed is:

1. A system, comprising:

a call processing server in communication with a call router operatively connectable to a communication network, said call router forwarding a session invite originating from a calling terminal to said call processing server, said session invite including a message header having a call destination field;

a multiple contact lookup application associated with said call processing server configured to obtain a plurality of

12

contact numbers associated with a primary contact number contained in said destination field;

a calling application associated with said call processing server configured to send said session invite to each of said plurality of contact numbers associated with said primary contact number;

a call connection application associated with said call processing server configured to establish a communication session between said calling terminal and a call reception terminal associated with a respective one of said plurality of contact numbers if a user accepts said session invite sent to said call reception terminal; and

a voicemail email application configured to automatically generate an email notification that is sent to a designated email account indicating receipt of a voicemail message.

2. The system of claim **1**, further comprising an application configured to present a caller using said calling terminal with a first option to attempt to directly contact said user or a second option to leave a voice mail message for said user during said initial session.

3. The system of claim **1**, further comprising a voicemail application for allowing a caller using said calling terminal to record a voicemail message if said user does not accept said session invite.

4. The system of claim **1**, further comprising a web-enabled control panel accessible by said user configured to allow said user to add contact numbers to said plurality of contact numbers, delete contact numbers from said plurality of contact numbers, and temporarily deactivate contact numbers contained in said plurality of contact numbers.

5. The system of claim **1**, further comprising a call answering application associated with said call processing server configured to establish an initial session between said calling terminal and said call processing server.

6. The system of claim **1**, wherein said communication session comprises a VoIP communication session.

7. The system of claim **1**, wherein said session invite comprises a SIP message and said communication session comprises a VoIP communication session.

8. A method, comprising:

receiving a call from a calling terminal designating a primary contact number with a call processing server;

retrieving a plurality of contact numbers correlated to said primary contact number;

establishing an initial session between said calling terminal and said call processing server;

attempting to establish a communication session with a plurality of call reception terminals associated with each contact number contained in said plurality of contact numbers;

establishing said communication session with a respective one of said call reception terminals if a recipient accepts said call using said respective one of said call reception terminals;

establishing a voice based communication session between said calling terminal and said call reception terminal if said recipient chooses to answer said call and forwarding said call to voicemail if said recipient chooses to forward said call to voicemail; and

generating an email notification that is sent to a designated email address indicating receipt of a voicemail message.

9. The method of claim **8**, further comprising generating a sound that is played to an initiator of said call on said calling terminal during said initial communication session.

10. The method of claim **8**, further comprising prompting an initiator of said call for a greeting during said initial session

13

and playing said greeting to said user prior to presenting said user with said option to answer said call or forward said call to voicemail.

11. The method of claim 8, further comprising providing a web-enabled control panel configured to display said plurality of contact numbers to said recipient, said web-enabled control panel being further configured to allow said recipient to edit contact numbers stored in said plurality of contact numbers, delete contact numbers stored in said plurality of contact numbers, and temporarily deactivate contact numbers stored in said plurality of contact numbers.

12. The method of claim 8, further comprising providing a web-enabled control panel configured to allow said recipient to control whether said call reception terminal displays a caller identification number associated with said first terminal or said primary contact number.

13. The method of claim 8, further comprising automatically transmitting said voice mail message to a designated email address of said recipient.

14. A system, comprising:

a web browser based control panel allowing a user to correlate a plurality of contact numbers to a primary contact number;

a database for storing said plurality of contact numbers linked to said primary contact number;

a call processing server operatively connectable to a communication network, said call processing server being

14

configured to receive a session invite designating said primary contact number from a calling terminal;

a lookup application configured to query said database to retrieve said plurality of contact numbers as a function of said primary contact number in response to said session invite;

a calling application configured to create a set of session invites to a plurality of call reception terminals assigned to said plurality of contact numbers; and

a session establishment application for establishing a session between said first terminal and a respective one of said plurality of second terminals if said user accepts said session invite on a respective second terminal.

15 15. The system of claim 14, said web browser based control panel being configured to allow said user to temporarily disable one or more of said plurality of contact numbers correlated to said primary contact number.

16. The system of claim 14, said web browser based control panel being configured to allow said user to activate and deactivate a call screening option.

17. The system of claim 14, said web browser based control panel being configured to allow said user to either display a caller identification number associated with said first terminal or said primary contact number.

18. The system of claim 14, wherein said web browser based control panel is configured to allow said user to activate and deactivate a do not disturb option.

* * * * *