

EXHIBIT F



US006298064B1

(12) **United States Patent**
Christie

(10) **Patent No.:** **US 6,298,064 B1**
(45) **Date of Patent:** **Oct. 2, 2001**

(54) **BROADBAND TELECOMMUNICATIONS SYSTEM**

OTHER PUBLICATIONS

- (75) Inventor: **Joseph Michael Christie**, San Bruno, CA (US)
- (73) Assignee: **Sprint Communications Company, L. P.**, Kansas City, MO (US)
- (*) Notice: Subject to any disclaimer, the term of this patent is extended or adjusted under 35 U.S.C. 154(b) by 0 days.

This patent is subject to a terminal disclaimer.

- (21) Appl. No.: **09/504,408**
- (22) Filed: **Feb. 15, 2000**

Related U.S. Application Data

- (63) Continuation of application No. 09/353,401, filed on Jul. 15, 1999, which is a continuation of application No. 08/525,897, filed on Sep. 8, 1995, now Pat. No. 5,991,301, which is a continuation-in-part of application No. 08/568,551, filed on Dec. 7, 1995, now Pat. No. 5,825,780, which is a continuation of application No. 08/238,605, filed on May 5, 1994, now abandoned.

- (51) **Int. Cl.⁷** **H04L 12/56; H04L 12/28**
- (52) **U.S. Cl.** **370/410; 370/466**
- (58) **Field of Search** 370/385, 386, 370/389, 395, 396, 397, 398, 399, 409, 410, 422, 426, 466, 467, 465; 379/229, 230, 231

(56) **References Cited**

U.S. PATENT DOCUMENTS

- 4,453,247 6/1984 Suzuki et al. .
- 4,720,850 1/1988 Oberlander et al. .
- 4,763,317 8/1988 Lehman et al. .

(List continued on next page.)

McDysan, David E. and Spohn, Darren L., ATM Theory And Application, 1994, p. 256: 9.3.1; ATM Layer VPI/VCI Level Addressing.

“Revised Draft Of Q.2650 (DSS2/B-ISUP Interworking Recommendation),” Study Group 11, Geneva, ITU—Telecommunication Standardization Sector, Nov. 29–Dec. 17, 1993.

“Draft Broadband/Narrowband NNI Networking Recommendation,” Study Group 11, Geneva, ITU—Telecommunication Standardization Sector, Dec. 1993.

Yoshikai, N., et al., “General Arrangements for Interworking Between B-ISDN and 63kbit/s Based ISDN (Draft Recommendation I.580), Study Group 13,” ITU-T Telecommunication Standardization Sector, pp. 1–51, (Mar. 7, 1994).

“Interworking B-ISUP and Q.93B for DDI, MSN, TP and SUB”, Study Group 11, Temporary Document 2/II-311, ITU—Telecommunication Standardization Sector, Nov. 29–Dec. 17, 1993.

Minoli, Daniel/DVI Communications, Inc./Stevens Institute of Technology and Dobrowski, George/Bell Communications Research (Bellcore), Principles Of Signaling For Cell Relay And Frame Relay © pp. 1–2, 5–6 and 229, 1994.

(List continued on next page.)

Primary Examiner—Ajit Patel

(74) *Attorney, Agent, or Firm*—Harley R. Ball; Steven J. Funk

(57) **ABSTRACT**

The invention is a system for providing virtual connections through an ATM interworking multiplexer on a call-by-call basis. A signaling processor receives signaling for a call and selects the virtual connection for the call. The signaling processor generates new signaling that identifies the selection and transfers the new signaling to the ATM interworking multiplexer that accepted the access connection for the call. The multiplexer converts user information from the access connection into ATM cells for transmission over the virtual connection in accord with the new signaling.

68 Claims, 12 Drawing Sheets

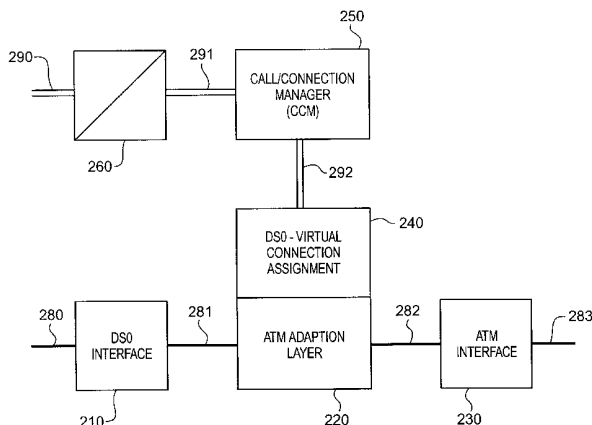

US 6,298,064 B1

Page 2

U.S. PATENT DOCUMENTS

4,926,416	5/1990	Weik .	
5,051,983	9/1991	Kammerl .	
5,115,431	5/1992	Williams et al. .	
5,168,492	12/1992	Beshai et al. .	
5,204,857	4/1993	Obara .	
5,233,607	8/1993	Barwig et al. .	
5,274,680	12/1993	Sorton et al. .	
5,327,421	7/1994	Hiller et al. .	
5,339,318	8/1994	Tanaka et al. .	
5,345,445	9/1994	Hiller et al. .	
5,345,446	9/1994	Hiller et al. .	
5,365,524	11/1994	Hiller et al. .	
5,392,402	2/1995	Robrock, II .	
5,414,701	5/1995	Shtayer et al. .	
5,420,858	5/1995	Marshall et al. .	
5,422,882	6/1995	Hiller et al. .	
5,426,636	6/1995	Hiller et al. .	
5,428,607	6/1995	Hiller et al. .	
5,428,609	6/1995	Eng et al. .	
5,434,852	7/1995	La Porta et al. .	
5,452,296	9/1995	Shimizu .	
5,452,297	9/1995	Hiller et al. .	
5,459,722	10/1995	Sherif .	
5,473,679	* 12/1995	La Porta et al.	370/410
5,479,402	12/1995	Hata et al. .	
5,483,527	* 1/1996	Doshi et al.	370/410
5,509,010	4/1996	LaPorta et al. .	
5,530,724	6/1996	Adrams et al. .	
5,570,368	10/1996	Murakami et al. .	
5,577,039	11/1996	Won et al. .	
5,623,491	4/1997	Skoog .	
5,623,493	4/1997	Kagemoto .	
5,673,262	9/1997	Shimizu .	
5,684,792	11/1997	Ishihara .	
5,771,234	6/1998	Wu et al. .	
5,787,086	7/1998	McClure et al. .	
5,805,568	9/1998	Shinbashi .	
5,825,780	10/1998	Christie .	
5,926,482	7/1999	Christie .	
5,991,301	11/1999	Christie .	
		6,014,378	1/2000 Christie et al. .
		6,016,319	* 1/2000 Kshirsagar et al. 370/410
		6,016,343	1/2000 Hogan et al. .
		6,023,474	2/2000 Gardner .
		6,064,648	* 5/2000 Hellman et al. 370/410
		6,067,299	5/2000 DuRee .
		6,081,529	6/2000 Christie .
		6,115,380	9/2000 Christie et al. .
		6,172,977	1/2001 Christie et al. .

OTHER PUBLICATIONS

McKinney, Scott, "ATM for Narrowband Services" 2460 IEEE Communications Magazine, Apr., 1994, New York, US, pp. 64-72.

Kuribayashi, Shin-Ichi, "Advanced Signaling Protocol for Broadband Services" Electronics and Communications in Japan, Part 1, vol. 78 No. 1, 1995, January, New York, US, pp. 1-12.

ITU-TQ. 1208, General Aspects of the Intelligent Network Application Protocol, ITU-T Recommendation Q.1208.

ITU-T Q.1218 Addendum 1, Series Q: Switching and Signalling Intelligent Network, Interface Recommendation for Intelligent Network CS-1, Addendum 1: Definition for two new contexts in the SDF data model.

Tanabe, Shirou, et al., "A New Distributed Switching System Architecture for B-ISDN," International Conference on Integrated Broadband Services and Networks, Oct. 15-18, 1990. The Institution of Electrical Engineers, Savory Place, London.

Palmer, Rob, et al., "An Experimental ATM Network Featuring De-Coupled Modular Control," IEEE Region 10 Conference, TENCON, Nov. 1992.

ITU-T Recommendation I.121 (Arp., 1991) Broadband Aspects of ISDN.

ITU-T Recommendation H.200 (Mar., 1993) Framework for Recommendations for Audiovisual Services.

* cited by examiner

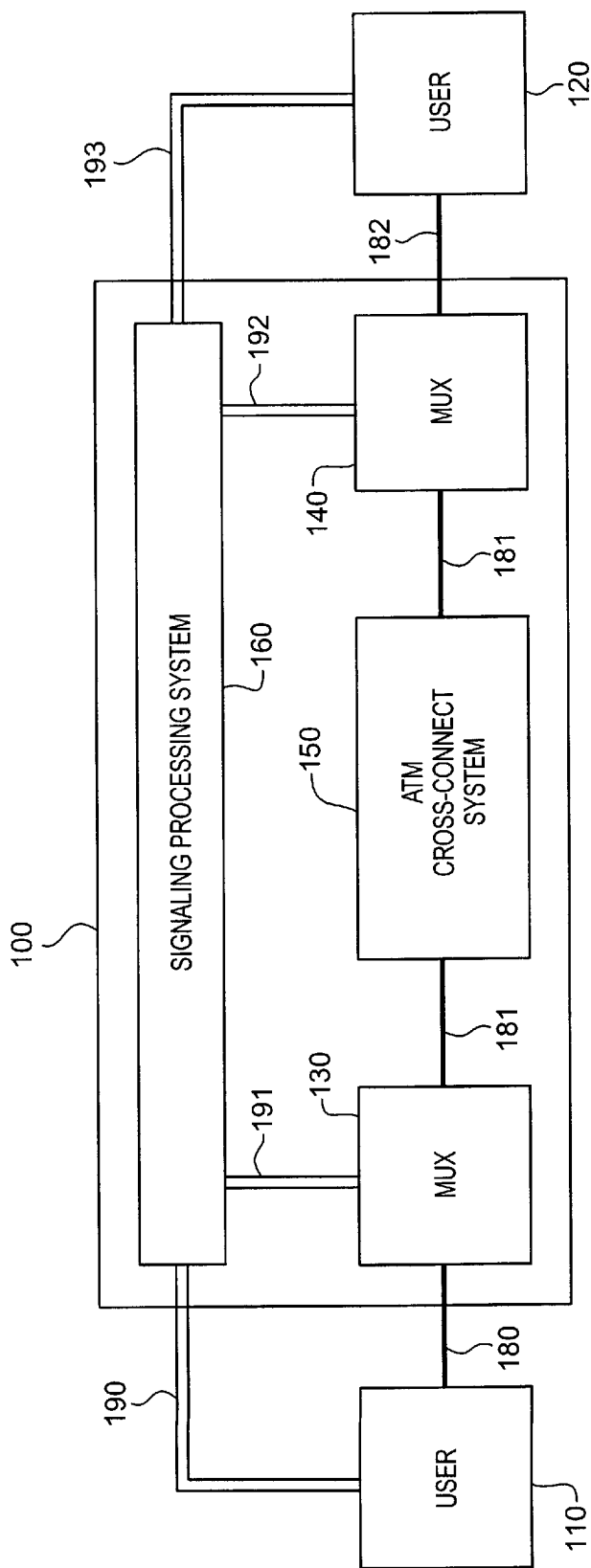

FIG. 1

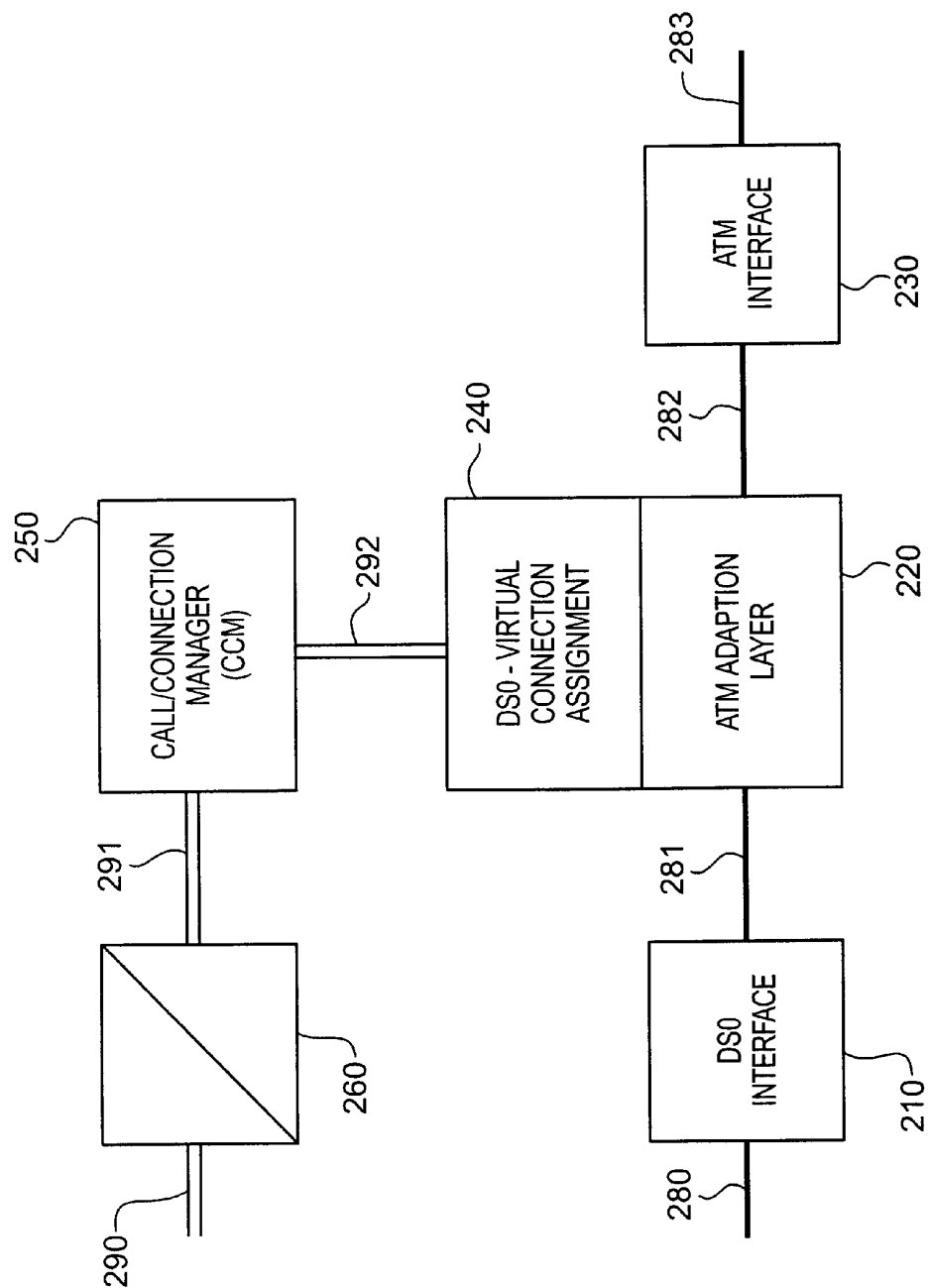

FIG. 2

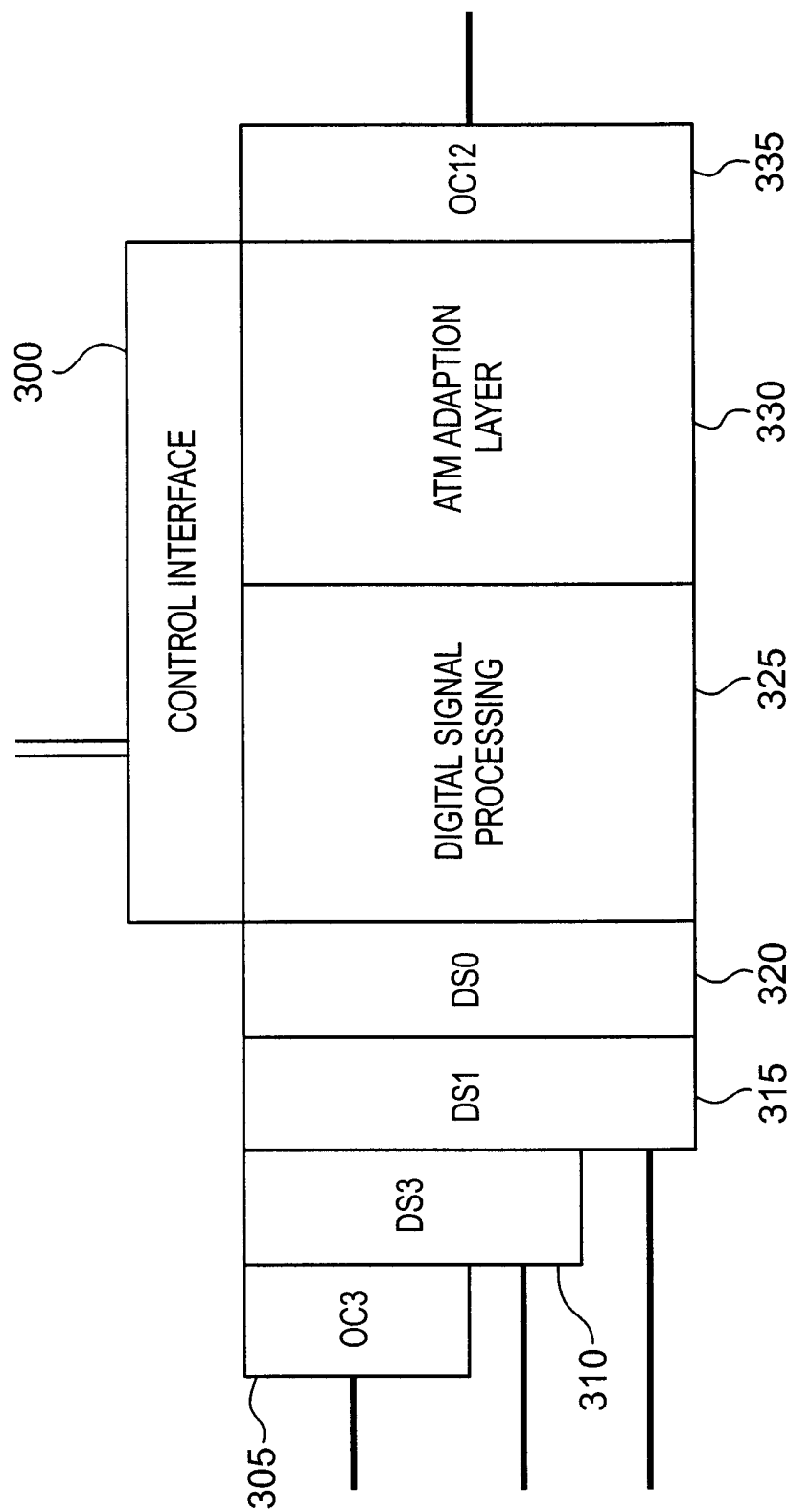

FIG. 3

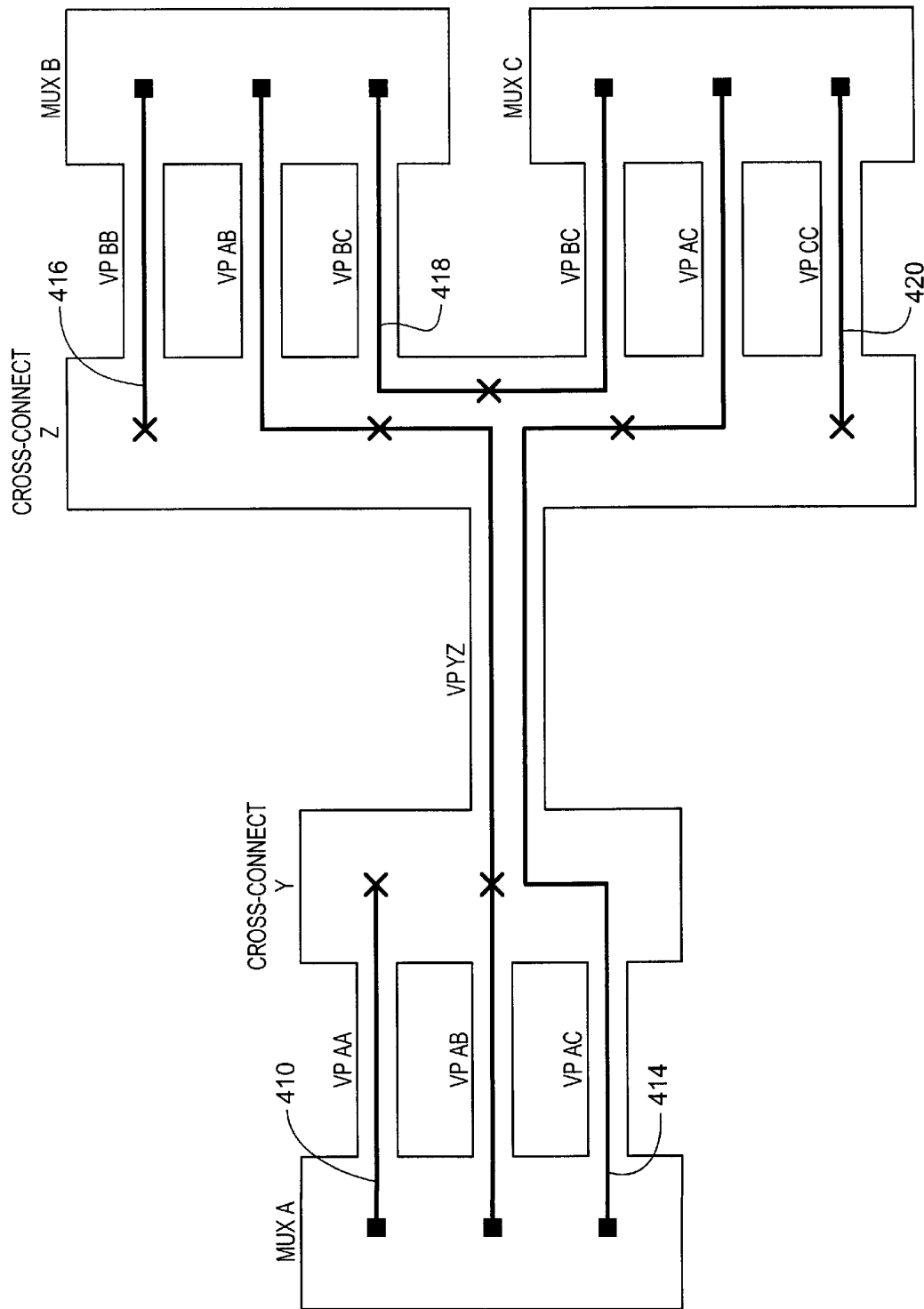

FIG. 4

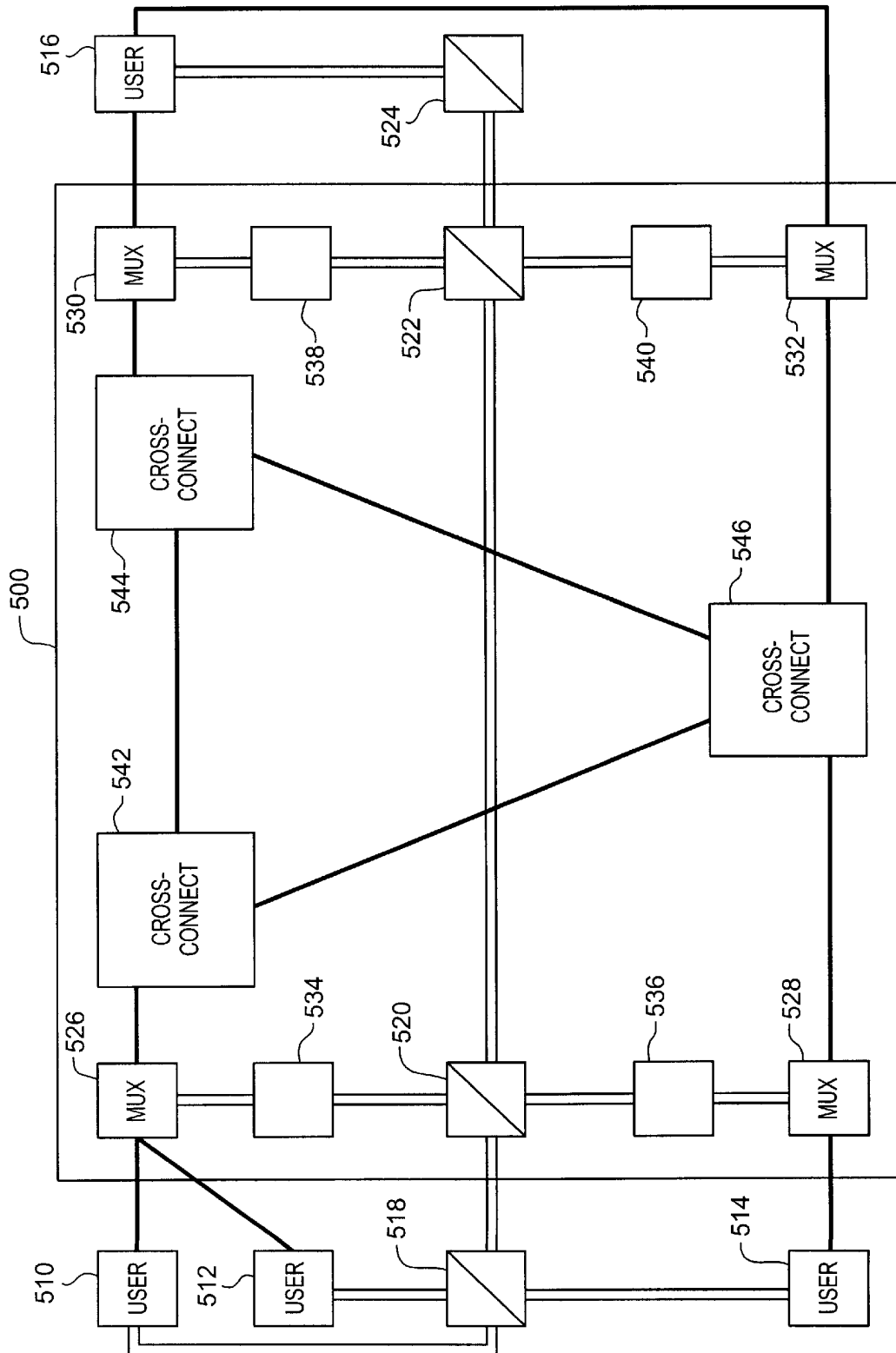

FIG. 5

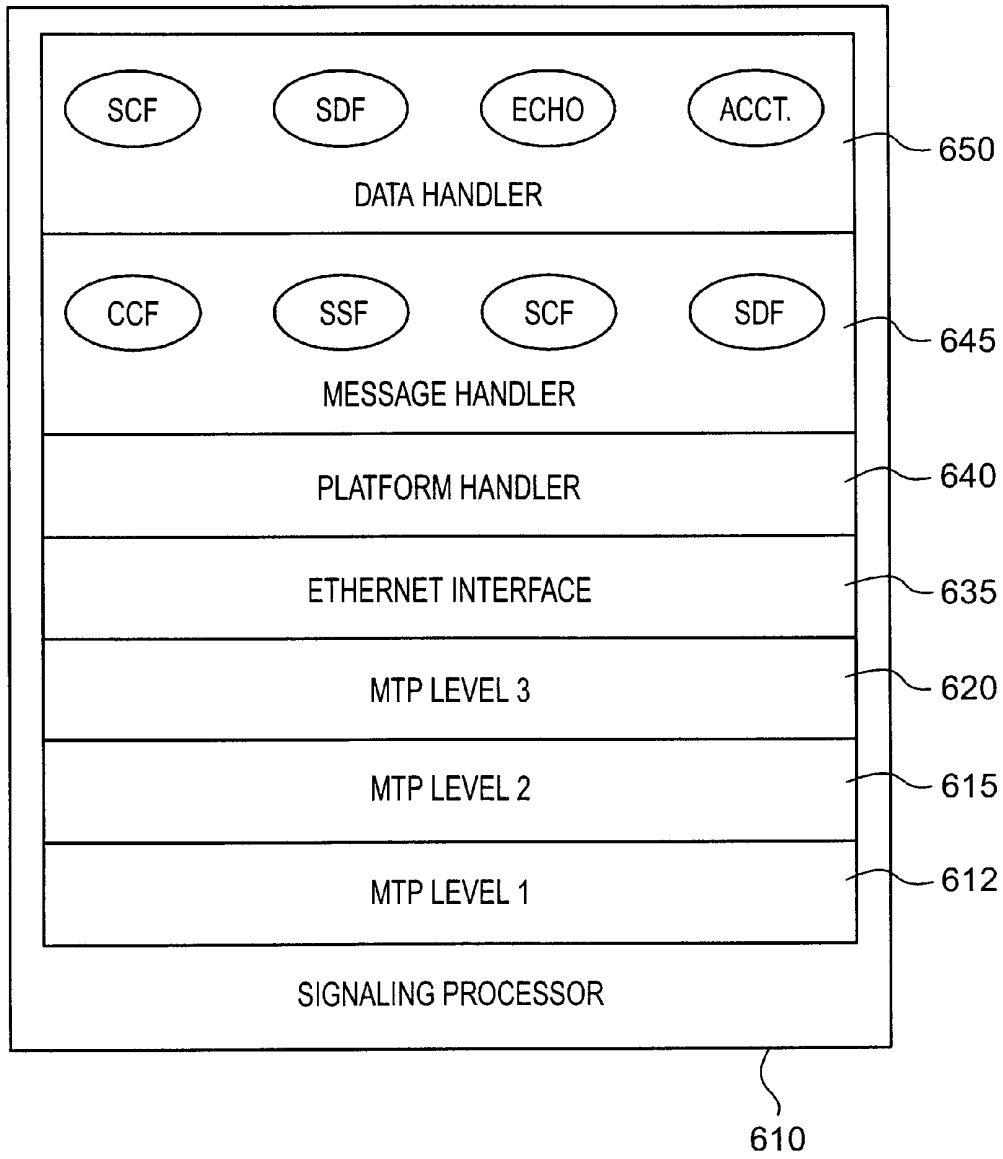

FIG. 6

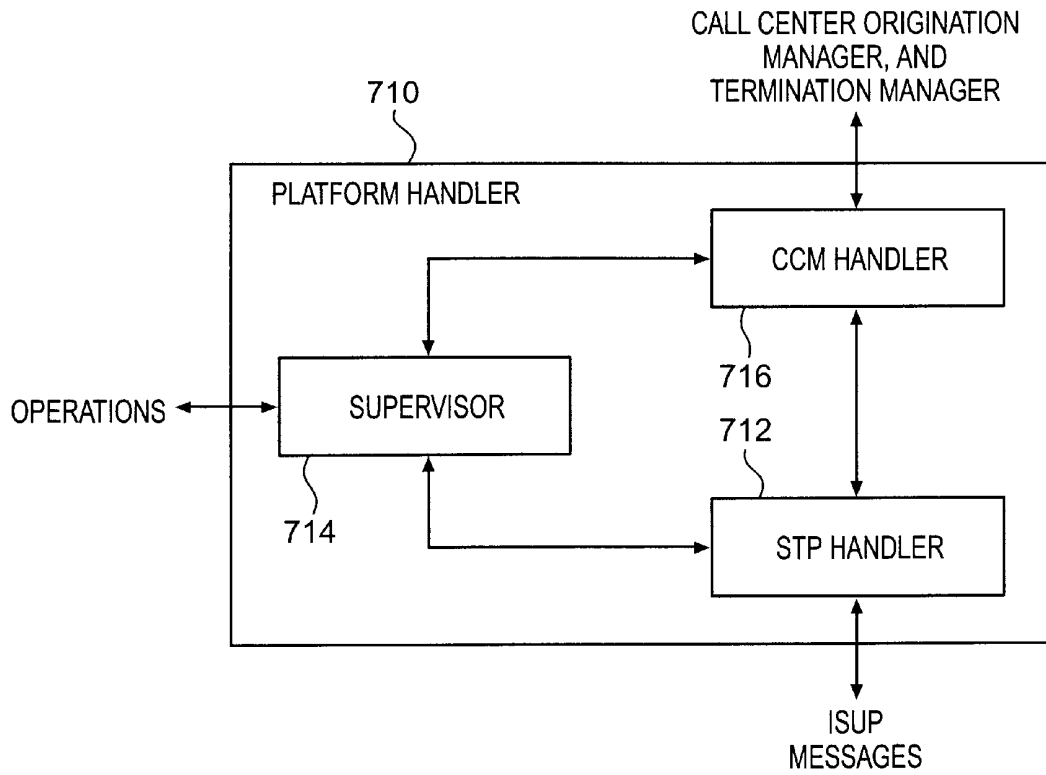

FIG. 7

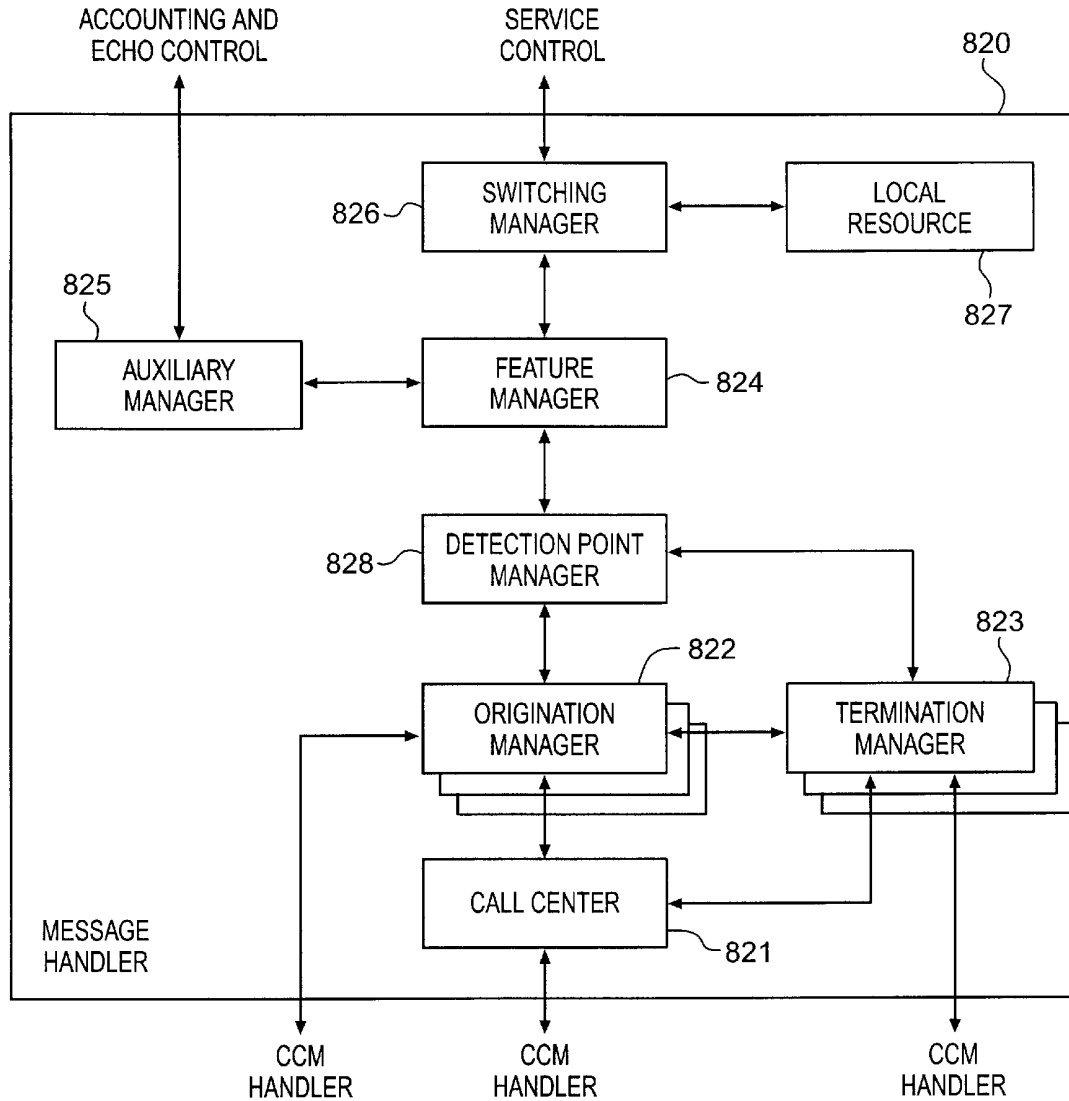

FIG. 8

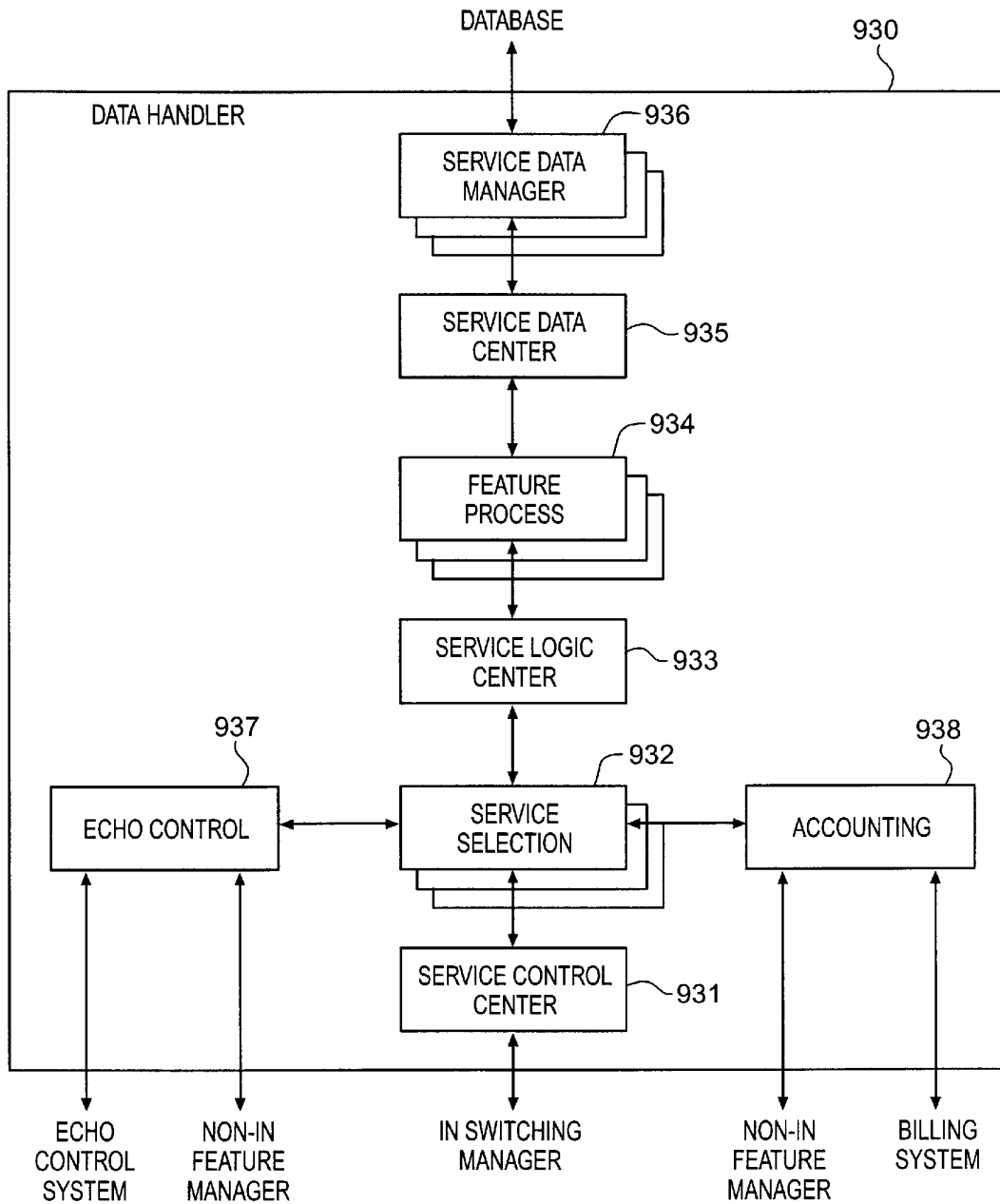

FIG. 9

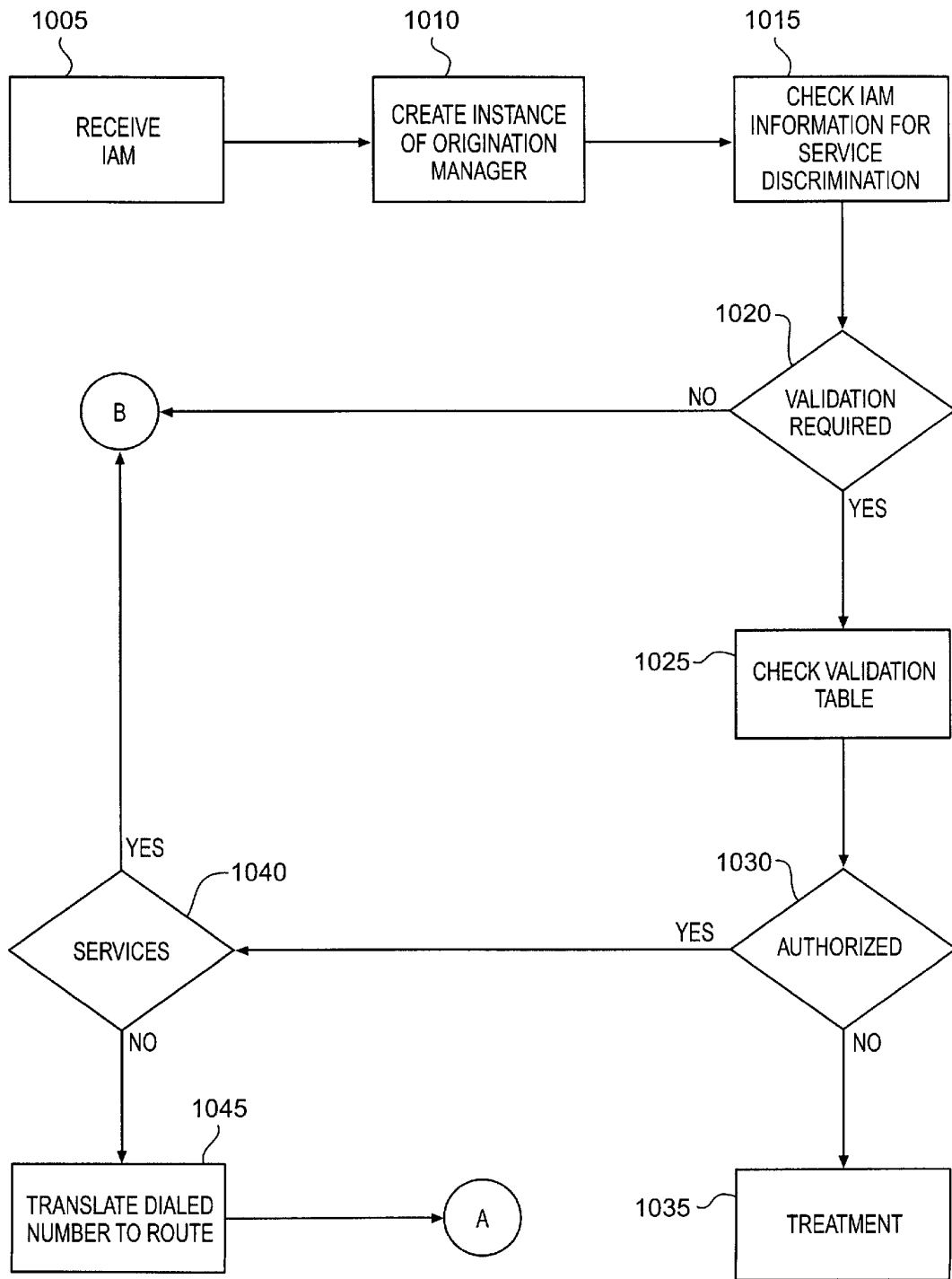

FIG. 10

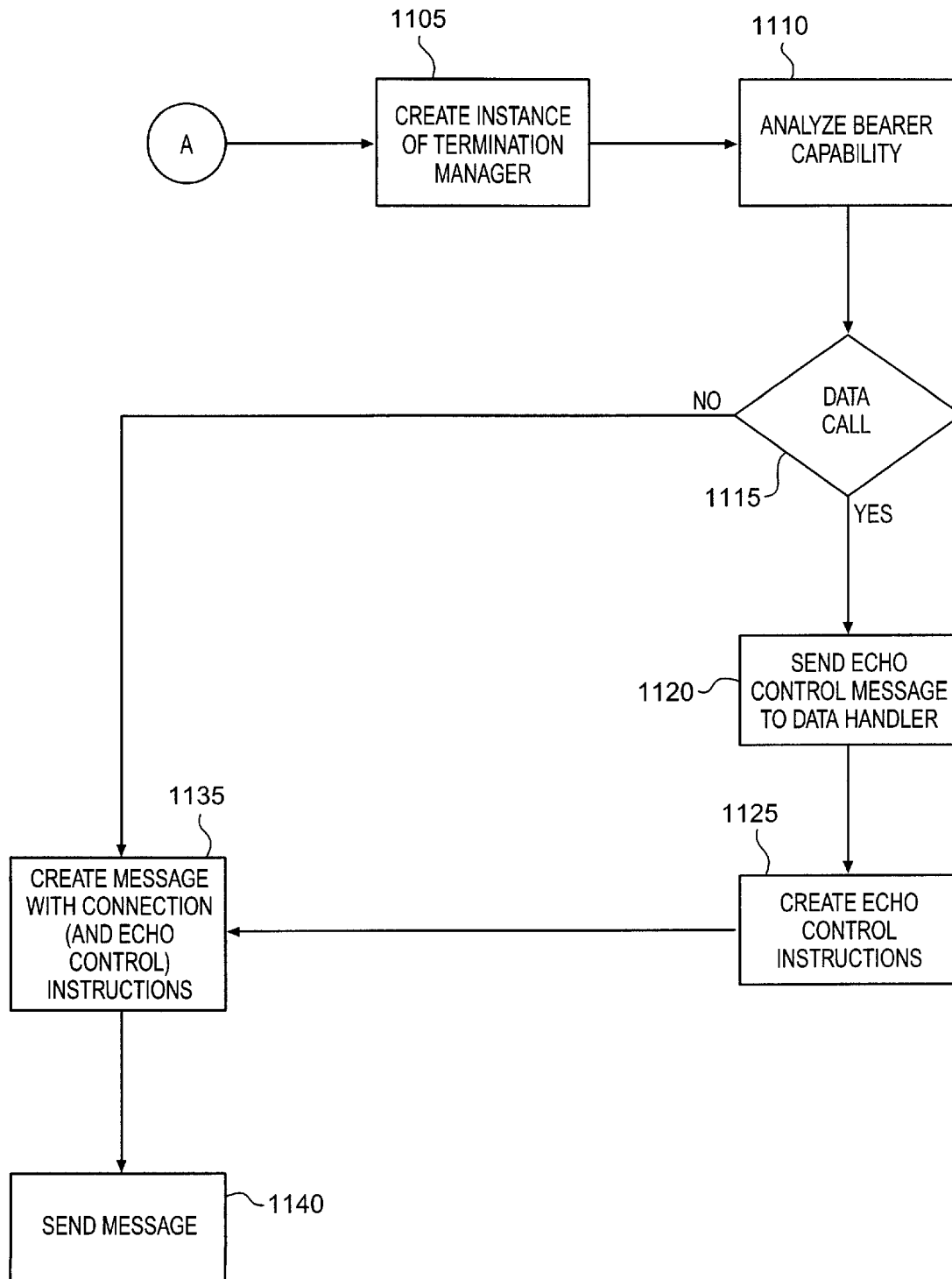

FIG. 11

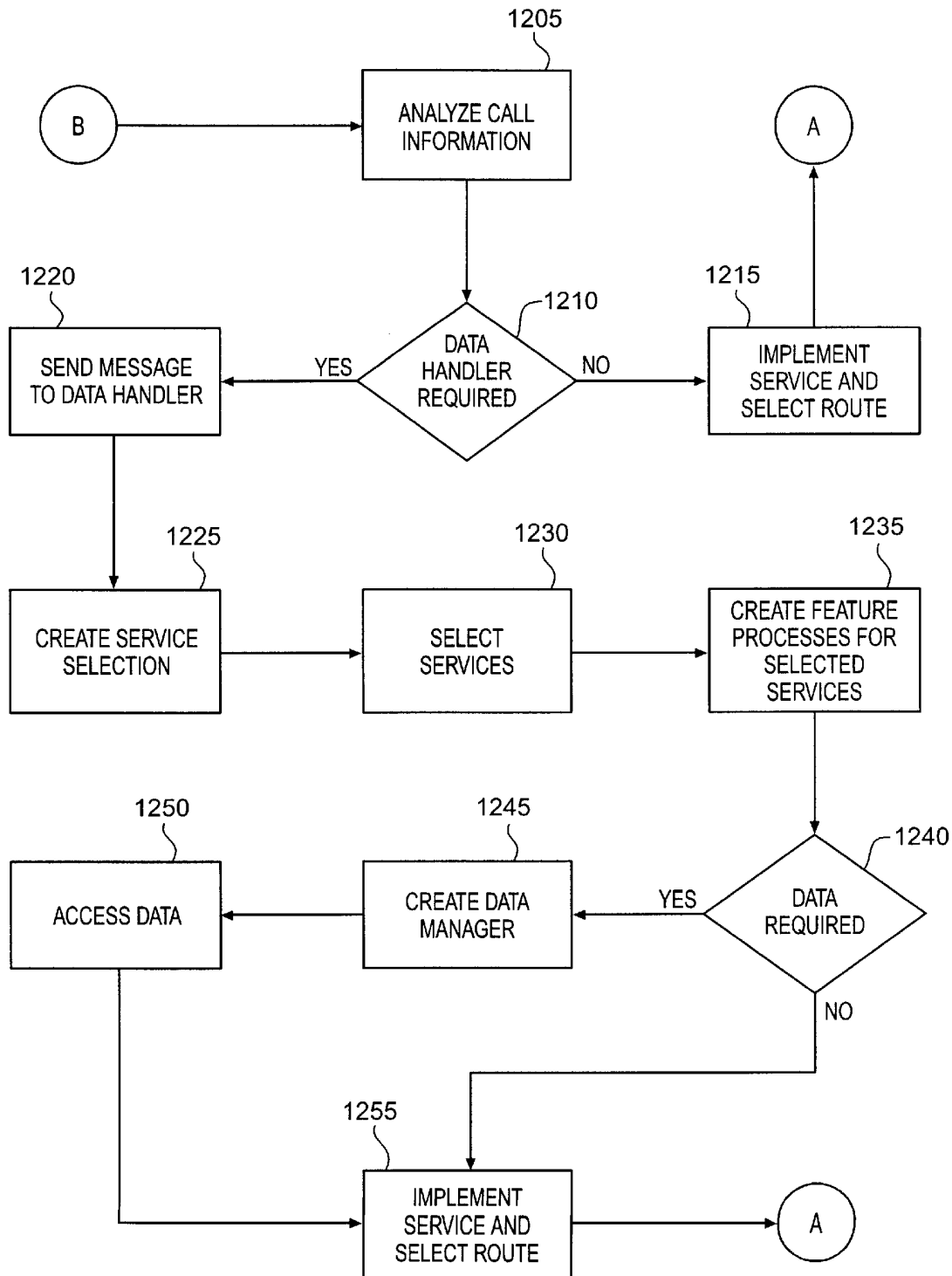

FIG. 12

US 6,298,064 B1

1

**BROADBAND TELECOMMUNICATIONS
SYSTEM****CROSS-REFERENCE TO RELATED
APPLICATIONS**

This application is a continuation of U.S. patent application Ser. No. 09/353,401, entitled "BROADBAND TELECOMMUNICATIONS SYSTEM", filed Jul. 15, 1999, which is incorporated by reference into this application and which is a continuation of U.S. patent application Ser. No. 08/525,897, filed on Sep. 8, 1995, which is incorporated by reference into this application, and which is a continuation-in-part of U.S. Pat. No. 08/568,551, filed Dec. 7, 1995, now U.S. Pat. entitled "METHOD, SYSTEM, AND APPARATUS FOR TELECOMMUNICATIONS CONTROL", which is incorporated by reference into this application, and which is a continuation of U.S. patent application Ser. No. 08/238,605, filed May 5, 1994, now abandoned, which is incorporated by reference into this application.

BACKGROUND

At present, Asynchronous Transfer Mode (ATM) technology is being developed to provide broadband switching capability. Some ATM systems have used ATM cross-connects to provide virtual connections. Cross-connect devices do not have the capacity to process signaling. Signaling refers to messages that are used by telecommunications networks to set-up and tear down calls. Thus, ATM cross-connects cannot make connections on a call by call basis. As a result, connections through cross-connect systems must be pre-provisioned. They provide a relatively rigid switching fabric. Due to this limitation, ATM cross-connect systems have been primarily used to provide dedicated connections, such as permanent virtual circuits (PVCs) and permanent virtual paths (PVPs). But, they do not provide ATM switching on a call by call basis as required to provide switched virtual circuits (SVCs) or switched virtual paths (SVPs). Those skilled in the art are well aware of the efficiencies created by using SVPs and SVCs as opposed to PVCs and PVPs. SVCs and SVPs utilize bandwidth more efficiently.

ATM switches have also been used to provide PVCs and PVPs. Since PVCs and PVPs are not established on a call-by-call basis, the ATM switch does need to use its call processing or signaling capacity. ATM switches require both signaling capability and call processing capability to provide SVCs and SVPs. In order to achieve virtual connection switching on a call by call basis, ATM switches are being developed that can process calls in response to signaling to provide virtual connections for each call. These systems cause problems because they must be very sophisticated to support current networks. These ATM switches must process high volumes of calls and transition legacy services from existing networks. An example would be an ATM switch that can handle large numbers of POTS, 800, and VPN calls. This generation of sophisticated ATM switches is not yet mature and should be expensive when they are first deployed.

Currently, ATM multiplexers are being developed that can interwork traffic into ATM cells and multiplex the cells for transport over an ATM network. One example of an application of these muxes is provided by T1 transport over an ATM connection. Traffic that leaves the switch in T1 format is muxed into ATM cells for transport over a high speed connection. Before the cells reach another switch, they are converted back into the T1 format. Thus, the ATM mux is

2

used for high speed transport. The ATM mux is not used to select virtual connections on a call-by-call basis. Unfortunately, there is not a telecommunications system that can provide ATM switching on a call by call basis without relying on the call processing and signaling capability of an ATM switch.

SUMMARY

The invention includes a method of operating a telecommunications system to provide a call with a virtual connection. The method is for use when a user places the call by sending signaling for the call to the telecommunications system and by transmitting user information to the telecommunications system over a particular connection. The system comprises an ATM interworking multiplexer and a signaling processor linked to the ATM interworking multiplexer. The method comprises receiving the signaling for the call into the signaling processor, processing the signaling to select the virtual connection, generating new signaling to identify the particular connection and the selected virtual connection, and then transmitting the new signaling to the ATM interworking multiplexer. The method also includes receiving the user information for the call from the particular connection into the ATM interworking multiplexer, converting the user information into ATM cells that identify the selected virtual connection in response to the new signaling, and transmitting the ATM cells over the selected virtual connection. The signaling for the call could be a call set-up message, such a Signaling System #7 (SS7) initial address message (IAM). The method could also include applying digital signal processing (DSP) to the call in the multiplexer in accord with DSP requirements selected by the signaling processor. DSP requirements could include echo control or encryption.

The invention also includes a telecommunications system to provide a call with a virtual connection in response to signaling for the call. The system comprises a signaling processor to receive and process signaling to select the virtual connection for the call, and to generate and transmit new signaling that identifies the selected virtual connection. The system includes an ATM interworking multiplexer to receive user information from a connection, convert the user information into ATM cells that identify the selected virtual connection, and transmit the ATM cells over the selected virtual connection. The system could also include an ATM cross-connect system connected to the ATM interworking multiplexer and configured to provide a plurality of virtual connections to the ATM interworking multiplexer.

The invention also includes an ATM interworking multiplexer for providing calls with virtual connections in response to signaling for each of the calls. The multiplexer comprises an access interface to receive user information for each call from a particular connection. It also includes a control interface to receive signaling for each call that identifies the particular connection and a virtual connection for that call. It also includes an ATM adaption processor to convert user information from the particular connection for each call into ATM cells that identify the virtual connection for that call. The multiplexer also includes an ATM interface to transmit the ATM cells for each call over the virtual connection. The multiplexer could include a digital signal processor to apply digital signal processing to the user information for each call. The processing could include echo control and encryption.

In various embodiments, the invention accepts calls placed over DS0 voice connections and provides virtual

US 6,298,064 B1

3

connections for the calls. In this way, broadband virtual connections can be provided to narrowband traffic on a call-by-call basis without requiring the call processing and signaling capability of an ATM switch.

BRIEF DESCRIPTION OF THE DRAWINGS

FIG. 1 is a block diagram of a version of the present invention.

FIG. 2 is a block diagram of a version of the present invention.

FIG. 3 is a block diagram of a version of the present invention.

FIG. 4 is a block diagram of a version of the present invention.

FIG. 5 is a block diagram of a version of the present invention.

FIG. 6 depicts a logic diagram of a version of the invention.

FIG. 7 depicts a logic diagram of a version of the invention.

FIG. 8 depicts a logic diagram of a version of the invention.

FIG. 9 depicts a logic diagram of a version of the invention.

FIG. 10 depicts a flow diagram of a version of the invention.

FIG. 11 depicts a flow diagram of a version of the invention.

FIG. 12 depicts a flow diagram of a version of the invention.

DETAILED DESCRIPTION

For purposes of clarity, the term “connection” will be used to refer to the transmission media used to carry user traffic. The term “link” will be used to refer to the transmission media used to carry signaling. On the Figures, connections are shown by a single line and signaling links are shown by double lines.

FIG. 1 depicts a version of the present invention. Shown is telecommunications system 100, user 110, and user 120. Telecommunications system 100 includes ATM interworking multiplexer (mux) 130, mux 140, ATM cross-connect system 150, and signaling processing system 160. User 110 is connected to mux 130 by connection 180. Mux 130 and mux 140 are connected through cross-connect system 150 by connection 181. Mux 140 is connected to user 120 by connection 182. Signaling processing system 160 is linked to user 110 by link 190, to mux 130 by link 191, to mux 140 by link 192, and to user 120 by link 193.

Those skilled in the art are aware that large networks have many more components than are shown. For example, there would typically be a multitude of virtual connections through ATM cross-connect system 150. The number of these components has been restricted for clarity. The invention is fully applicable to a large network.

User 110 and user 120 could be any entity that supplies telecommunications traffic to network 100. Some examples would be a local exchange carrier (LEC) switch or customer premises equipment (CPE). Typically, the user traffic would be provided to system 100 in DS3, DS1, or OC-3 format that have embedded DS0 and VT 1.5 circuits. Connections 180 and 182 represent any connection that might be used by user 120 to access system 100 and would also include formats such as E1, E3, and DS2. As such, these connections are

4

periodically referred to as access connections. Connections 180 and 182 would typically be DS0 connections embedded within a DS3 connection, however, the invention fully contemplates other connection being used with a few examples being a fractional DS1, a clear DS3, or even SONET OC-3. Links 190 and 193 are any links capable of transferring signaling messages with an example being Signaling System #7 (SS7) links. ATM cross-connect system 150 is any system that provides a plurality of virtual connections. Such a system could be comprised of individual ATM cross-connect devices interconnected by ATM connections using DS3 or SONET for transport. An example of an ATM cross-connect is the NEC Model 10. Connection 181 could be any virtual connection. Typically, the virtual connection would use DS3 or SONET for transport. ATM cross-connect system 150 would be pre-provisioned to provide a plurality of virtual connections through the cross-connect system, and virtual connection 181 represents one of these connections. As virtual connections are logical paths, many physical paths can be used based on the pre-provisioning of ATM cross-connect system 150. Links 191 and 192 could be any links capable of transporting data messages. Examples of such links could be SS7 or UDP/IP. The components described in this paragraph are known in the art.

Signaling processing system 160 is any processing platform that can receive and process signaling to select virtual connections, and then generate and transmit signaling to identify the selections. Various forms of signaling are contemplated by the invention, including SS7, C7, and user to network interface (UNI) signaling. A preferred embodiment of the signaling processor is discussed in detail toward the end of the disclosure.

Mux 130 could be any muxing system operable to place user information arriving over connection 180 on the virtual connection selected by signaling processing system 160. Typically, this involves receiving signaling messages from signaling processing system 160 that identify assignments of virtual connections to an access connection on a call by call basis. The mux would convert user traffic from access connection 180 into ATM cells that identify the selected virtual connection. Mux 140 is similar to mux 130. A preferred embodiment of these muxes are also discussed in detail below.

The system would operate as follows for a call from user 110 to user 120. User 110 would send a signaling message over link 190 to system 100 initiating the call. Signaling processing system 160 would process the message. Such processing could include validation, screening, translating, route selection, echo control, network management, signaling, and billing. In particular, a virtual connection through ATM cross-connect system 150 from mux 130 to mux 140 would be selected, and a connection from mux 140 to user 120 would also be selected. Although many possible connections would be available, only the selected connections are shown—connection 181 and connection 182. Generally, the selection is based on the dialed number, but call processing can entail many other factors with a few examples being network loads and user routing instructions. Signaling processing system 160 would then send signaling reflecting the selections to mux 130 and mux 140.

User 110 would also seize a connection to system 100. The connection is represented by connection 180 to mux 130. Although, only one connection is shown for purposes of clarity, numerous connections would typically be available for seizure. The seized connection would be identified in the signaling from user 110 to system 100. Signaling processing

US 6,298,064 B1

5

system **160** would include the identity of this connection in its signal to mux **130**.

If required, user **120** would receive signaling to facilitate completion of the call. The signaling from signaling processing system **160** would indicate that system **100** was connecting to user **120** over connection **182**. Typically, user **120** would accept and acknowledge the connection in a signaling message back to system **100**.

Mux **130** would receive signaling from signaling processing system **160** identifying connection **180** as the access connection and connection **181** as the selected virtual connection through ATM cross-connect system **150**. Mux **130** would convert the user information from connection **180** into ATM cells. Mux **130** would designate connection **181** in the cell headers. Connection **181** would have been previously provisioned through ATM cross-connect system **150** from mux **130** to mux **140**.

Mux **140** would receive signaling from signaling processing system **160** identifying connection **181** as the selected virtual connection and connection **182** as the selected access connection to user **120**. Mux **140** would convert cells arriving on connection **181** to user information suitable for connection **182** to user **120**. Although the above example employs two muxes, a single mux could be employed for calls that enter and exit system **100** through the same mux. In this case, the ATM system would simply provide a virtual connection back to the same mux.

From the above discussion, it can be seen that multiple virtual connections can be pre-provisioned through an ATM cross-connect system to interconnect ATM interworking multiplexers. When a user places a call, one of the virtual connections is selected for the call by the signal processing system and identified to the appropriate muxes. The muxes convert the user information into cells that identify the selected connection. As such, user information can be switched through an ATM fabric on a call by call basis. The system does not require the call processing or signaling capabilities of an ATM switch (although an ATM switch could be used to provide the virtual connections without using its call processing and signaling functions). The system can also implement enhanced services such as **N00** and virtual private network (VPN).

FIG. 2 depicts another embodiment of the invention. In this embodiment, the user information from the access connection is capable of being muxed to the **DS0** level, but this is not required in other embodiments. Additionally, **SS7** signaling is used in this embodiment, but other signaling protocols, such as **C7** or **UNI** signaling, are also applicable to the invention.

Shown are **DS0** interface **210**, ATM adaption layer (AAL) **220**, ATM interface **230**, **DS0**—virtual connection assignment **240**, call/connection manager (CCM) **250** and signal transfer point (STP) **260**. Also shown are connections **280–283** and links **290–292**.

Connection **280** could be any connection or group of connections that contain information that can be converted to **DS0** format. Examples of these connections are **OC-3**, **VT1.5**, **DS3**, and **DS1**. **DS0** interface **210** is operable to convert user information in these formats into the **DS0** format. AAL **220** comprises both a convergence sublayer and a segmentation and reassembly (SAR) layer. AAL **220** is operational to accept the user information in **DS0** format from **DS0** interface **210** and convert the information into ATM cells. AALs are known in the art and information about AALs is provided by International Telecommunications Union (ITU) document **I.363.1**. An AAL for voice is also

6

described in patent application Ser. No. 08/395,745, filed on Feb. 28, 1995, entitled “Cell Processing for Voice Transmission”, and hereby incorporated by reference into this application. ATM interface **230** is operational to accept ATM cells and transmit them over connection **283**. Connection **283** is a standard **DS3** or **SONET** connection transporting ATM cells. Connection **281** is operational for the **DS0** format and connection **282** is operational to transfer ATM cells.

It can be seen that a communications path through connections **280–283** could be established to carry user information. Although the communications path has been described from connection **280** to connection **283**, the invention contemplates components that are also operational to perform reciprocal processing in the reverse direction. If the communications path is bi-directional, user information in ATM cells arriving on connection **283** would be processed for output on connection **280** in the appropriate format. Those skilled in the art will appreciate that separate connections could also be set up in each direction, or that only a connection in one direction may be required. These components and their operation are known in the art.

Signaling links **290** and **291** are **SS7** links. Link **292** is a data link with an example being an ethernet connection transporting **UDP/IP**. **STP 260** is device that routes signaling messages. **STPs** are well known in the art. **CCM 250** would be identified by its own signaling point code. **STP 260** would route signaling messages addressed to this point code to **CCM 250**. In some embodiments, **STP 260** may also convert other point codes to the point code for **CCM 250** so these signaling messages are also routed to **CCM 250**. Although point code conversion is not essential, it facilitates the transition of a network to the system of the invention. The conversion could be implemented through a conversion table located between level **2** and level **3** of the message transfer part (**MTP**) function of **STP 260**. The conversion table would convert the destination point code of the message to that of **CCM 250**, so that the route function of **MTP 3** would forward the message to **CCM 250**. Point code conversion could be based on many factors with a few examples being the destination point code, the origination point code, the signaling link, the circuit identification code, the message type, and various combinations of these and other factors. For example, **SS7** Integrated Services User Part (**ISLUP**) messages with particular **OPC/DPC** combinations could have the **DPC** converted to the point code of **CCM 250**. These signaling messages would then be routed to **CCM 250** by **STP 260**. One version of a suitable **STP** is disclosed in U.S. patent application entitled “Telecommunications Apparatus, System, and Method with Enhanced Signal Transfer Point”, filed simultaneously with this application, assigned to the same entity, and hereby incorporated by reference into this application.

CCM 250 is a signaling processor that operates as discussed above. A preferred embodiment of **CCM 250** is provided later. In this embodiment **CCM 250** would be operable to receive and process **SS7** signaling to select connections, and to generate and transmit signaling identifying the selections.

Assignment **240** is a control interface that accepts messages from **CCM 250**. In particular, assignment **240** identifies **DS0**/virtual connection assignments in the messages from link **292**. These assignments are provided to AAL **220** for implementation. As such, AAL **220** obtains the virtual path identifier (**VPI**) and virtual channel identifier (**VCI**) for each call from assignment **240**. AAL **220** also obtains the identity of the **DS0** for each call (or the **DSOs** for an **Nx64**

US 6,298,064 B1

7

call). AAL 220 then converts user information between the identified DS0 and the identified ATM virtual connection. Acknowledgments that the assignments have been implemented may be sent back to CCM 250 if desired.

In operation, calls are processed as follows. Signaling messages for calls arrive on link 290 and are routed by STP 260 to CCM 250. Access connections are typically seized contemporaneously with the signaling. All of these connections are represented by connection 280. DS0 interface 210 would convert the traffic on connection 280 into the DS0 format and provide the DSOs to AAL 220 over connection 281.

The signaling received by CCM 250 would identify the access connections for the calls (i.e. the particular DSOs on connection 280), and contain call information, such as a dialed number. CCM 250 would process the signaling and select connections for the call. Since multiple virtual connections are pre-provisioned from ATM interface 230 to the other destinations in the network, CCM 250 can select a virtual connection to the destination. The selection process can be accomplished through table look-ups. For example, a table could be used to translate a portion of the dialed number into a VPI. The VCI would be selected based on the available VCIs in the selected VPI. The VPI/VCI combination would correspond to a unique virtual connection pre-provisioned from ATM interface 230 to the appropriate network destination. The selections represent the DS0—virtual connection assignments that are provided to assignment 240 over link 292.

Assignment 240 accepts the DS0—virtual connection assignments and provides them to AAL 220. When AAL 220 receives a particular assignment, it converts user information from the designated DS0 into cells that identify the designated VPI/VCI. The cells are provided to ATM interface 230 over connection 282. ATM interface 230 accepts the cells and places them within the transport format for connection 283. The cells are then transported over the selected virtual connection to the appropriate destination.

Calls also exit the network through connection 280. In this case, CCMs at the origination points select the virtual connections to ATM interface 230. The originating CCMs also send signaling messages to CCM 250. The signaling messages identify the destinations for the calls and the selected virtual connections. CCM 250 will have a list of available access connections to the identified destinations. CCM 250 will select the access connections to the destination from the list. For example, the connection selected by CCM 250 could be a DS0 embedded within a DS3 connected to a LEC. The virtual connections on connection 283 and selected access connections on connection 280 are provided to assignment 240 over link 292. Assignment 240 provides these assignments to AAL 220.

ATM interface 230 will demux the cells arriving from connection 283 and provide them to AAL 220. AAL 220 converts the user information in the cells into the DS0 format. AAL 220 make the conversion so that cells from a particular virtual connection are provided to the assigned DS0 on connection 281. DS0 interface will convert the DSOs from connection 281 into the appropriate format, such as DS3, for connection 280. Those skilled in the art are aware of the techniques for muxing and transporting DS0 signals.

From the above discussion, it can be seen that user information for calls can flow from connection 280 to connection 283, and in the reverse direction from connection 283 to connection 280. DS0 interface 210 and ATM interface

8

230 provide user information in their respective formats to AAL 220. AAL 220 converts the user information between DS0 and ATM formats based on the assignments from assignment 240. CCM 250 can select the DS0—virtual connection assignments that drive the process.

The ATM Interworking Multiplexer

FIG. 3 shows one embodiment of the mux that is suitable for the present invention, but muxes that support the requirements of the invention are also applicable. Shown are control interface 300, OC-3 interface 305, DS3 interface 310, DS1 interface 315, DS0 interface 320, digital signal processing(DSP) 325, AAL 330, and OC-12 interface 335.

OC-3 interface 305 accepts the OC-3 format and makes the conversion to DS3. DS3 interface 310 accepts the DS3 format and makes the conversion to DS1. DS3 interface 310 can accept DS3s from OC-3 interface 305 or from an external connection. DS1 interface 315 accepts the DS1 format and makes the conversion to DS0. DS1 interface 315 can accept DS1s from DS3 interface 310 or from an external connection. DS0 interface 320 accepts the DS0 format and provides an interface to digital signal processing (DSP) 325.

DS0 interface 320 is coupled to DSP 325. DSP 325 is capable of manipulating the user information to improve transmission quality. DSP processing primarily entails echo cancellation, but could include other features as well. As is known, echo cancellation can be required for voice calls. DSP 325 passes the DSOs through echo cancellers. These echo cancellers must be disabled for calls that do not require echo control. Data calls do not require echo cancellation, and the CCM has the ability to recognize data calls that require an echo canceller to be disabled. The CCM will send a control message through control interface 300 to DSP 325 indicating the particular echo canceller that is to be disabled. The CCM selects the echo canceller based on the CIC in the signaling it receives from the user. After the data call, the CCM sends a message that causes the particular echo canceller to be enabled again for subsequent voice calls. The above technique of applying echo control is preferred, but other means of implementing echo control instructions from the CCM are also applicable.

In addition to echo control, the CCM and the mux can work to provide other digital signal processing features on a call by call basis. Compression algorithms can be applied, either universally, or on a per call basis. The decibel level could be adjusted for calls from a particular origin or to a particular destination, i.e. where a hearing impaired person may reside. Encryption could be applied on a call-by-call basis based on various criteria like the origination number or the destination number. Various DSP features could be associated with various call parameters and implemented by the CCM through DSP 325.

DSP 325 is connected to AAL 330. AAL 330 operates as described above for an AAL. DSO—virtual connection assignments from control interface 300 are implemented by AAL 330 when converting between the DS0 and ATM formats.

Calls with a bit rate greater than 64 kbit/sec. are known as Nx64 calls. If desired, AAL 330 can be capable of accepting control messages through control interface 300 from the CCM for Nx64 calls. The CCM would instruct AAL 330 to group the DSOs for the call.

The ATM Cross-connect System

FIG. 4 depicts virtual connections provided by the ATM cross connect system in a version of the invention, although

US 6,298,064 B1

9

numerous other techniques for providing virtual connections will be appreciated by one skilled in the art, and the invention contemplates any such system. Shown are virtual connections **410**, **412**, **414**, **416**, **418**, and **420**. These virtual connections are shown interconnecting muxes A, B, and C through cross-connects Y and Z. Virtual connections are provisioned in between each mux. Each mux would have a virtual path to the cross-connect system that is designated for each possible destination mux. Virtual path AB contains virtual connection **412** from mux A to mux B. For calls that originate and terminate at the same mux, virtual connections **410**, **416**, and **420** are provisioned for that purpose. Virtual connections **414** and **418** connect muxes A/C and B/C respectively. Alternate routes for different virtual connections can be provisioned between the same two muxes.

Within each virtual path are thousands of virtual channels (not shown). Virtual connections are provisioned by cross-connecting VPI/VCI combinations at cross-connects Y and Z. If a call enters mux A and needs to terminate at mux B, the CCM will select virtual path AB. The selection could be based on a translation of the dialed number. Within virtual path AB, the CCM would select the particular virtual channel. This selection could be based on available VCIs within the VPI. In this way, pre-provisioned virtual connections can be selected on a call by call basis.

Typically, calls will require a bidirectional voice connection. For this purpose, a virtual connection must transport user information in both directions. The virtual connections can be provisioned so that the mux at the terminating end may use the same VPI/VCI for cells transported in the opposite direction. The terminating CCM could also translate the originating VPI/VCI into another VPI/VCI provisioned in the opposite direction and provide this VPI/VCI to the terminating mux.

Additionally, the number of active virtual connections in between cross-connects can be tracked. Virtual path YZ connects cross-connects Y and Z. The capacity of virtual path YZ would be sized based on network requirements, but should it become overloaded, the CCMs can be programmed to select an alternate virtual path.

Operation Within a Network

FIG. 5 depicts an embodiment of the invention with respect to a specific telecommunications network scenario, although the invention is not limited to this specific scenario. FIG. 5 shows telecommunications system **500**. Shown are user **510**, user **512**, user **514**, user **516**, STP **518**, STP **520**, STP **522**, STP **524**, mux **526**, mux **528**, mux **530**, mux **532**, call/connection manager (CCM) **534**, CCM **536**, CCM **538**, CCM **540**, ATM cross-connect **542**, ATM cross-connect **544**, and ATM cross-connect **546**. For clarity, the connections and signaling links are not numbered. All of these components are described, and the CCMs are also discussed below.

In operation, user **510** may forward an **800** call to system **500**. User **510** could be connected to mux **526** with a DS3 connection. The **800** call would occupy a DS0 embedded in the DS3 connected to mux **526**. User **510** would send an SS7 Initial Address Message (IAM) through STP **518** to system **500**. STP **520** would be configured to route the IAM to CCM **534**. An IAM contains information such as the dialed number, the caller's number, and the circuit identification code (CIC). The CIC identifies the DS0 used by user **510** for the call.

CCM **534** would process the IAM and identify that the call was an **800** call. Either through its own database or by accessing a service control point (SCP) (not shown), the

10

CCM would translate the dialed number based on the **800** subscriber's routing plan. For example, **800** calls from user **510** may be routed to user **512** during business hours, to user **514** at night, and to user **516** on weekends. If the call is placed from user **512** on a weekend, the call would be routed to user **516**. As such, CCM **534** would select a pre-provisioned virtual connection from mux **526** through ATM cross-connect **542** and ATM cross-connect **544** to mux **530**. CCM **534** would send an IAM message to CCM **538** through STP **520** and STP **522**. The IAM would indicate that a call was being routed to user **516** and would identify the selected virtual connection being used to reach mux **530**.

Typically, mux **530** would be connected to user **516** with a DS3 connection. CCM **538** would select a DS0 embedded in the DS3 and would send an LAM to user **516** through STP **522** and STP **524**. The CIC of the LAM would indicate that a call was being routed to user **516** over the selected DSO. User **516** would process the IAM and complete the call. When the call is answered, user **516** would transmit an answer message (ANM) through STP **524** back to system **500**.

CCM **534** would also send a UDP/IP message to mux **526** instructing it to assemble the user information in the DS0 from user **510** into ATM cells with a cell header identifying the selected virtual connection. CCM **538** would send a UDP/IP message to mux **530** instructing it to dis-assemble ATM cells from the selected virtual connection and output the user information to the selected DS0 to user **516**. ATM cross-connect **542** would route ATM cells from mux **526** to ATM cross-connect **544** based on the cell header. Likewise, ATM cross-connect **544** would route these cells to mux **530** based on the cell header. As such, user information for the call would flow from user **510** to user **516** over the DS0 from user **510**, the virtual connection selected by CCM **534**, and the DS0 to user **516** selected by CCM **538**. The muxes would implement the selections of the CCMs.

The call would require that a voice channel be available in both directions. As such, the DSOs and virtual connection would be bi-directional. Cut-through on the receive channel (from the user **516** to the user **510**) would occur after the address complete message (ACM) had been received by system **500**. Cut-through on the transmit channel (from the user **510** to the user **516**) would occur after the answer message (ANM) had been received by system **500**. This could be accomplished by not allowing mux **530** to release any cells for the call until the ANM has been received by system **500**.

If user **510** were to place the call at night, CCM **534** would determine that user **514** was the destination. Accordingly a pre-provisioned virtual connection from mux **526** through ATM cross-connect **542** and ATM cross-connect **546** to mux **528** would be selected for the call. CCM **536** would select the DS0 to user **514**.

If user **510** were to place the call during the day, CCM **534** would determine that user **512** was the destination. Accordingly a pre-provisioned virtual connection from mux **526** through ATM cross-connect **542** and back to mux **526** would be selected for the call. CCM **534** would also select the DS0 to user **512**.

The Call/Connection Manager (CCM)

FIGS. 6-12 refer to a preferred embodiment of the signaling processor, also known as the CCM, but any processor which supports the requirements stated for the invention would suffice. FIG. 6 depicts a signaling processor suitable for the invention. Signaling processor **610** would

US 6,298,064 B1

11

typically be separate from the mux, but those skilled in the art appreciate that they could be housed together. Also, signaling processor may support a single mux or support multiple muxes.

Signaling processor **610** includes Message Transfer Part (MTP) level 1 **612**, MTP level 2 **615**, and MTP level 3 **620**. MTP level 1 **612** defines the physical and electrical requirements for a signaling link. MTP level 2 **615** sits on top of level 1 and maintains reliable transport over a signaling link by monitoring status and performing error checks. Together, MTP levels 1–2 provide reliable transport over an individual link. A device would need MTP level 1–2 functionality for each link it uses. MTP level 3 **620** sits on top of level 2 and provides a routing and management function for the signaling system at large. MTP level 3 **620** directs messages to the proper signaling link (actually to the MTP level 2 for that link). MTP level 3 **620** directs messages to applications using the MTP levels for access the signaling system. MTP level 3 **620** also has a management function which monitors the status of the signaling system and can take appropriate measures to restore service through the system. MTP levels 1–3 correspond to layers 1–3 of the open systems interconnection basic reference model (OSIBRF). Both the MTP 1–3 and the OSIBRF are well known in the art

Also shown for signaling processor **610** are ethernet interface **635**, platform handler **640**, message handler **645**, and data handler **650**. Ethernet interface **635** is a standard ethernet bus supporting TCP/IP which transfers signaling messages from MTP level 3 to platform handler **640**. Also, if UDP/IP is used to communicate with the muxes, ethernet interface **335** would accept the links to the muxes. Those skilled in the art will recognize other interfaces and protocols which could support these functions in accord with the invention.

In accord with this invention, the logic of the signaling interface (indicated by reference numerals **612**, **615**, **620**, and **635**) would be operational to route select ISUP messages to platform handler **640**. Technique for doing this have been discussed above. Preferably, an SS7 interface to platform handler **640** could be constructed using commercially available SS7 software interface tools. An example of such tools would be SS7 interface software provided by Trillium, Inc.

Platform handler **640** is a system which accepts ISUP and B-ISUP messages from ethernet interface **635** and routes them to message handler **645**. Preferably, platform handler **640** is configured to route messages to a particular message handler processor based on the signaling link selection (SLS) code in the message. Message handler **645** is a system which exchanges signaling with platform handler **640** and controls the connection and switching requirements for the calls. It can select and implement services and initiate echo control. It also converts signaling between ISUP and B-ISUP. Data handler **650** is a set of logic coupled to message handler **645** which processes service requests and provides data to message handler **645**. Data handler **650** also controls echo cancellers and generates billing records for the call.

In the discussions that follow, the term ISUP will include B-ISUP as well. In operation, ISUP messages that meet the proper criteria are routed by MTP and/or ATM interface **615**, MTP level 3 **620**, and ethernet interface **635** to platform handler **640**. Platform handler **640** would route the ISUP messages to message handler **645**. Message handler **645** would process the ISUP information. This might include validation, screening, and determining if additional data is

12

needed for call processing. If so, data handler **650** would be invoked and would provide message handler **645** with the relevant data so message handler **645** could complete call processing. Message handler **645** would generate the appropriate ISUP message to implement the call and pass the signals to platform handler **640** for subsequent transmission to the designated network elements.

The distribution of functional entities among message handler **645** and data handler **650** are shown. These functional entities are well known in the art. Message handler **645** includes at least the call control function (CCF) and the service switching function (SSF). The CCF establishes and releases call connections, and the SSF recognizes triggers during call processing by the CCF and provides an interface between the CCF and the service control function (SCF). The SCF identifies services and obtains data for the service. In some embodiments, message handler **645** can include the SCF and the service data function (SDF). The SDF provides service data in real time to the SCF. Taken together, message handler **645** is able to at least control connections and recognize triggers. In some embodiments, message handler **645** can also identify services, obtain data for the services, and generate the signaling required to implement the services. Message handler **645** can provide signaling interworking (i.e. ISUP to B-ISUP), connection control, service selection and service implementation in a logically integrated package that interfaces with the network through conventional means.

Data handler **650** includes at least the SCF and the SDF. In some embodiments, message handler **645** and data handler **650** both include the SCF and the SDF and services are partitioned among the functional entities. Two other functions are shown in data handler that are not standardized functional entities. Accounting generates a billing record and echo handles the echo cancellers. Typically, an echo canceller is disabled for a data call and enabled after the data call for use on subsequent voice calls, however, other techniques are applicable.

In operation, the CCF would perform basic call processing until the SSF recognized a trigger and invoked the SCF. The SCF would identify the service associated with the trigger. The SCF would access data from the SDF in order to implement the service. The SCF would process the data from the SDF and provide the data to the CCF through the SSF. The CCF would then set-up the connections through conventional signaling to service switching points (SSPs). The SSPs are connected to the communications path and make the connections. Typically, an SSP is a switch. Also, echo cancellers may be controlled for the call, and a billing record could be generated for the call.

Those skilled in the art are aware of various hardware components which can support the requirements of the invention. For example, the platform handler, message handler, and data handler could each reside on a separate SPARC station **20**.

The Platform Handler

FIG. 7 shows a possible version of the platform handler. Platform handler **710** is shown. Platform handler **710** includes STP handler **712**, supervisor **714**, and CCM handler **716**. Platform handler **710** transmits and receives ISUP messages to/from the signaling interface (reference numerals **312**, **315**, **320**, and **335**). STP handler **712** would provide the ethernet—TCP/IP interface. STP handler **712** has a process to buffer and dis-assemble the incoming packets to the CCM, and buffer and assemble outgoing packets. STP

US 6,298,064 B1

13

handler **712** could also check the messages for basic flaws. Any technique for transfer of signaling messages to platform handler **710** is contemplated by the invention.

Supervisor **714** is responsible for managing and monitoring CCM activities. Among these are CCM start-up and shut-down, log-in and log-off of various CCM modules, handling administrative messages (i.e. error, warning, status, etc.) from the CCM modules, and handling messages from network operations such as queries, configuration instructions, and data updates. The connection to network operations is the man machine interface which allows the CCM to be controlled and monitored by either a remote or a local operator. Supervisor **714** has a process which retrieves configuration data from internal tables to initialize and configure the CCM. The CCM modules also have internal tables which are used in conjunction with this procedure. Supervisor **714** also communicates internally with STP handler **712** and CCM handler **716**.

CCM handler **716** exchanges ISUP information with STP handler **712**. CCM handler **716** also exchanges ISUP messages and CCM supervisory messages with the message handler. The connection between CCM handler **716** and the message handler could be an ethernet LAN transporting these messages encapsulated in TCP/IP packets, but other methods are known. CCM handler **716** would provide the ethernet—TCP/IP interface. CCM handler **716** has a process to buffer and dis-assemble the incoming packets from the message handler, and buffer and assemble outgoing packets to the message handler. CCM handler **716** could also check the messages for basic flaws.

Internally, platform handler **710** is equipped with bi-directional channels which exchange information among STP handler **712**, supervisor **714**, and CCM handler **716**. The channels between STP handler **712**, CCM handler **716**, and supervisor **714** carry supervisory and administrative information. The channel between STP handler **712** and CCM handler **716** carries ISUP message information.

Platform handler **710** accepts, disassembles, and buffers ISUP messages received from the network. It can perform basic checks on the messages before transferring them to the message handler. Should more than one message handler be connected to platform handler **710**, the ISUP messages could be allocated to the message handlers based on the SLS of the particular ISUP message. CCM handler **716** accepts routing instructions from the message handler for routing certain ISUP messages to select processes of the message handler. Platform handler **710** also provides supervision and a man/machine interface for the CCM.

The Message Handler.

FIG. 8 depicts a version of the message handler. Message handler **820** is shown and includes call center **821**, origination manager **822**, termination manager **823**, detection point manager **828**, feature manager **824**, auxiliary manager **825**, switching manager **826**, and local resource **827**. A primary function of message handler **820** is to process ISUP messages.

Call center **821** is the process which receives call set-up messages from the platform handler. ISUP call set-up is initiated with the LAM. When call center **821** receives an IAM, it creates an instance of an origination manager process with data defined by the information in the IAM. Origination manager **822** represents any of the origination manager processes spawned by call center **821**. The CCM handler is instructed of the new instance so that subsequent ISUP messages related to that call can be transferred directly

14

to the appropriate instance of origination manager **822** by the platform handler.

Origination manager **822** sets up a memory block called an originating call control block. The call control block provides a repository for information specific to a call. For example, the originating call control block could identify the following: the call control block, the origination manager, the message handler, the originating LEC, the LEC trunk circuit (CIC), the ATM virtual circuit, the ATM virtual path, the caller's number, the dialed number, the translated dialed number, the originating line information, the ANI service class, the selected route, the number of the selected route, the SLS, the OPC, the DPC, the service indicator (SIO), echo cancellation status, reason of release, call status, and pointers to adjacent call control blocks. In addition, the call control block would also contain the various times that signaling messages are received, such the address complete message (ACM), the answer message (ANM), the suspend message (SUS), the resume message (RES), and the release message (REL). Those skilled in the art would be aware of other pertinent data to include.

Origination manager **822** executes call processing in accordance with the Basic Call State Model (BCSM) recommended by the International Telecommunications Union (ITU), but with some notable exceptions. Origination manager **822** processes the IAM through each point in call (PIC) until a detection point (DP) is encountered. When a detection point is encountered, a message is sent to detection point manager **828** and processing is suspended at origination manager **822** until detection point manager **828** responds. An example of a detection point for origination manager **822** would be to authorize an origination attempt.

Detection point manager **828** accepts messages from origination manager **822** caused by a detection point encountered during call processing. Detection point manager **828** will identify whether or not the detection point is armed. An armed detection point has specific criteria which can affect call processing if met. If the detection point is not armed, detection point manager **828** will send a continue signal back to origination manager **822**. A continue message instructs origination manager **822** to continue call processing to the next detection point. If the detection point is armed, detection point manager **828** will take action to see if the detection point criteria are met. If detection point manager **828** requires assistance to process the armed detection point, it will send a message to feature manager **824**.

Feature manager **824** would accept messages from detection point manager **828** and either forward the a message to auxiliary manager **825** or to switching manager **826**. Particular feature messages would be routed to auxiliary manager **825** which will process these call features. These are typically non-IN features, such as echo control or POTS billing. Other feature messages would be routed to switching manager **826**. These are typically IN features. Examples of IN features are **800** number translation or a terminal mobility number translation. Feature manager **824** will pass information back to detection point manager **828** (then to origination manager **822**) when it is received back from auxiliary manager **825** or switching manager **826**.

Switching manager **826** which will determine if the request will be handled by local resource **827** or by the data handler. Local resource **827** will be structured to provide data more efficiently stored at message handler **820**. Examples of such data include: an automatic number identification (ANI) validation table which checks the caller's number, a dialed number translation table to translate POTS

US 6,298,064 B1

15

numbers into a routing instructions, or **N00** translation tables to translate select **800** numbers into routing instructions. Examples of a routing instruction yielded by the tables would be a particular access connection or a virtual connection. An example of data in the data handler would be virtual private network (VPN) routing tables or complex **800** routing plans.

Typically, originating manager **822** will execute through the pertinent points in call to a point indicating that set up is authorized. At this point, origination manager **822** will instruct call center **821** to create an instance of a termination manager. Termination manager **823** represents any of these termination managers. Origination manager **822** will also transfer IAM information to termination manager **823**. Termination manager **823** sets up a memory block called a terminating call control block. The call control block provides a repository for information specific to a call and is similar in composition to the originating call control block.

Termination manager **823** also operates in accord with the BCSM of the ITU, but also with some exceptions. Termination manager **823** continues processing for the call through its own points in call until detection points are encountered. When a detection point is encountered, a message is sent to detection point manager **828** and processing is suspended at termination manager **823** until detection point manager **828** responds. An example of detection point for termination manager **822** would be to authorize termination which would entail authorizing the call as set-up by origination manager **822**. Messages from termination manager **823** to detection point manager **828** are handled as discussed above for messages from originating manager **822**. When processing by termination manager **823** is complete, it will produce a signaling message to transmit through platform handler **410** to the appropriate multiplexers, and possibly to the users.

Message handler **820** communicates with the data handler using a data transfer protocol. Examples include UDP/IP, or the Intelligent Network Applications Protocol (INAP) which is contained within the component sublayer of Transaction Capabilities Application Part (TCAP).

The Data Handler

FIG. 9 shows a version of the data handler. Data handler **930** is shown. Data handler **930** includes service control center **931**, service selection **932**, service logic center **933**, feature process **934**, service data center **935**, service data manager **936**, echo control **937**, and accounting **938**. Data handler **930** receives service request messages from the message handler. These messages result from an armed detection points triggering the message handler to invoke data handler **930**. The messages also result from features implemented through the auxiliary manager. Service control center **931**, service logic center **933**, and service data center **935** are static processes created at start-up. Service control center **931** creates instances of service selection managers on a call by call basis. Service control center **931** notifies the Switching manager to route subsequent service request messages for that call to the appropriate service selection manager. Service selection manager **932** represents any of the service selection managers created by service control center **931**.

Service selection manager **932** executes the service portion of the call processing. Service selection manager **932** identifies the various services associated with each message and implements the service through messages to service logic center **933**. Service logic center **933** accepts messages

16

from service selection **932** and creates instances of the feature processes required for the identified services. Examples of feature processes are **N00**, messaging, personal/terminal mobility, and virtual private network (VPN). Feature processes are service logic programs which implement the required services for a call. Feature process **934** represents any of the feature processes created by service logic center **933**. Feature process **934** accesses the network resources and data required to implement the service. This would entail executing service independent blocks (SIBs). A SIB is a set of functions. An example of a function would be to retrieve the called number from a signaling message. SIBs are combined to build a service. An example of a SIB is translating a called number.

Those skilled in the art are familiar with the above services, although they have never been implemented by a system such as the present invention. **N00** services are services such as 800, 900, or 500 calling in which the dialed number is used to access call processing and billing logic defined by the subscriber to the service. Messaging entails connecting the caller to a voice messaging service. For example, the receipt of a release message (REL) with a cause of busy could be a trigger recognized by the message handler. In response, the data handler would create an instance of the messaging feature process and determined if a call placed to a particular dialed number would require the voice messaging platform. If so, the CCM would instruct an SSP to connect the caller to the voice message platform. Personal/Terminal mobility includes recognizing that the dialed number has mobility that requires a database look-up to determine the current number. The database is updated when the called party changes locations. VPN is a private dialing plan. It is used for calls from particular dedicated lines, from particular calling numbers (ANIs), or to particular dialed numbers. Calls are routed as defined for the particular plan.

In the execution of the SIB to provide the service, feature process **934** would invoke service data center **935** to create an instance of service data manager **936**. Service data manager **936** accesses the network databases that provide the data required for the service. Access could be facilitated by TCAP messaging to an SCP. Service data manager **936** represents any of the service managers created by service data center **935**. Once the data is retrieved, it is transferred back down to feature process **934** for further service implementation. When the feature processes for a call finish execution, service information is passed back down to the message handler and ultimately to the origination or termination manager for the call.

After a release message on a call, billing requests will be forwarded to accounting **938**. Accounting **938** will use the call control block to create a billing record. The call control block would contain information from the ISUP messages for the call and from CCM processing. From the address complete message (ACM), the call control block would include the routing label, CIC, message type, and cause indicators. From the answer message (ANM), the call control block would include the routing label, CIC, message type, and backward call indicators. From the initial address message (IAM), the call control block would include the routing label, CIC, message type, forward call indicators, user service information, called party number, calling party number, carrier identification, carrier selection information, charge number, generic address, origination line information, original called number, and redirecting number. From the release message (REL), the call control block would include the routing label, CIC, message type, and

US 6,298,064 B1

17

cause indicators. From the suspend message (SUS) or the pass along message (PAM), the call control block would include the routing label, CIC, and message type. Those skilled in the art are familiar with other pertinent information for a billing record and appreciate that some of this information could be deleted.

For POTS calls, the billing request will come from the origination and termination managers through the auxiliary manager. For IN calls, the request will come from service selection **932**. Accounting **938** will generate a billing record from the call control blocks. The billing record will be forwarded to a billing system over a billing interface. An example of such an interface is the I.E.E.E. **802.3 FTAM** protocol.

At some point during call set-up, the origination manager, termination manager or even the detection point process will check the user service information data and originating line information to assess the need for echo control. If the call is a data call, a message is sent to data handler **930**. Specifically, the message is routed through the auxiliary manager to the echo control manager **937** in data handler **930**. Based on the CIC, echo control manager **937** can select which echo canceller and DS0 circuit needs to be disabled. A message will be generated to that effect and transmitted over a standard data link to the pertinent echo canceller or echo control system. As described above, echo control can be implemented by the multiplexer. Once a release (REL) message is received for the call, the echo canceller is re-enabled. On a typical call, this procedure will occur twice. Once for an echo canceller on the access side, and again for an echo canceller on the terminating side. The CCM that handles the IAM for a particular call segment will control the particular echo cancellers for the segment.

IAM Call Processing

Prior to a description of IAM processing, a brief description of SS7 message is given. SS7 messaging is well known in the art. SS7 ISUP messages contain numerous fields of information. Each message will have a routing label containing a destination point code (DPC), an origination point code (OPC), and a signaling link selection (SLS) which are used primarily for routing the message. Each message contains a circuit identification code (CIC) which identifies the circuit to which the message relates. Each message contains the message type which is used to recognize the message. ISUP messages also contain mandatory parts filled with fixed length data and variable length data, in addition to a part available for optional data. These parts vary from message type to message type depending on the information needed.

The initial address message (IAM) initiates the call and contains call set-up information, such as the dialed number. IAMs are transferred in the calling direction to set up the call. During this process, TCAP messages may be sent to access remote data and processing. When the IAMs have reached the final network element, an address complete message (ACM) is sent in the backward direction to indicate that the required information is available and the called party can be alerted. If the called party answers, an answer message (ANM) is sent in the backward direction indicating that the call/connection will be used. If the calling party hangs up, a release message (REL) is sent to indicate the connection is not being used and can be torn down. If the called party hangs up, a suspend message (SUS) is sent and if the called party reconnects, a resume (RES) message keeps the line open, but if their is no re-connection, a release

18

message (REL) is sent. When the connections are free, release complete messages (RLC) are sent to indicate that the connection can be re-used for another call. Those skilled in the art are aware of other ISUP messages, however, these are the primary ones to be considered. As can be seen, the IAM is the message that sets-up the call.

In the preferred embodiment, call processing deviates from the basic call model recommended by the ITU, although strict adherence to the model could be achieved in other embodiments. FIGS. **10-12** depicts the preferred call processing. Referring first to FIG. **10**, When the IAM for a call is received at **1005**, the call center creates an instance of an origination manager at **1010**.

The origination manager begins call processing by sending an authorize message to the detection point manager. Detection point manager checks IAM information, including the dialed number, the CIC, and the originating line information, to perform service discrimination at **1015**. This is done to determine if the service requested requires validation at **1020**. Current call processing systems and the BCSM of the ITU both validate the call before performing service discrimination. In a significant advance over the prior art, the preferred embodiment deviates from known call processing methods by looking at the IAM information prior to validation to determine if validation is even required. For example, the calling party may not pay the bill for a call. The called party pays the bill on 800 calls and validation can be unnecessary. If validation is not required at **1020**, call processing proceeds directly to B. Advantageously, this avoids unnecessary look-ups in validation tables for a significant percentage of calls.

If validation is required at **1020**, a validation table is checked at **1025**. Validation checks to see if a call should be allowed and focuses on potential billing problems for the call. For example, calls from ANIs that are delinquent on payments pose problems for billing and may not be validated. Validation would entail messaging from the detection point manager through the feature manager and the switching manager to the local resource to access the tables. The table may list authorized ANIs, unauthorized ANIs, or both. If the call is not authorized at **1030**, treatment (i.e. route to an operator or message) is given to the call at **1035**.

If the call is authorized at **1030**, the services identified at **1015** are checked at **1040** to determine if the call can be routed. This would typically occur for POTS calls. If no additional services are required at **1040**, the dialed number is translated into a route instruction at **1045**. The route instruction could be a particular virtual connection and/or access connections. The processing then proceeds to A. If additional services are required at **1040**, processing proceeds to B.

FIG. **11** picks up processing at B after a route has been selected. A termination manager is created at **1105**. The termination manager is responsible for processing in accordance with the terminating BCSM of the ITU. However, in some embodiments, the processing can exhibit some deviation. For example, detection points such as select facility and validate call may be skipped.

The bearer capability is analyzed at **1110** to determine if the call is a data call at **1115**. This analysis could occur elsewhere in the call processing (i.e. by the origination manager after the route is selected.) If a data call is found at **1115**, an echo control message is sent to the data handler at **1120**. Echo control instructions are created at **1125**. The echo control instructions identify the connection for the call which requires echo control. The message could be sent to

the echo control system over a conventional data link from the CCM to the echo control system. If, the echo control is implemented in the multiplexers, the echo control message could be included with the route instruction message.

If the call is not a data call at 1115 or after echo control processing at 1125, a signaling message is created at 1135. The new signaling message identifies the access connections and virtual connection for the call. The new signaling message can also contain echo control instructions. The new signaling message is sent to the platform handler at 1140.

FIG. 12 picks up the processing at B. At this point, several things are known about the call concerning authorization and service requirements. The call information is then analyzed at 1205 as required to apply services to the call. If the data handler is not required at 1210, the service is implemented and the route is selected at 1215. This may occur if a service can be directly implemented by the origination manager or through the local resource. For example, particular 800 translations or dialed number service profiles (i.e call forwarding) can be stored in the local resource. In this case, route selection would be performed by the local resource after the information is analyzed to identify the correct entry to a local resource database. When the local resource is used, the messages must be routed from the detection point processor through the feature manager and switching manager to the local resource.

If the data handler is required for the call at 1210, a message is sent to the data handler at 1220. The messaging typically flows from the detection point processor to the feature manager and switching manager to the data handler. Upon receipt of the message at the data handler, the service control center creates an instance of the service selection process at 1225. The service selection process analyzes the message from the detection point processor and selects the feature processes for the call at 1230. For example, a call may be placed from a caller in a virtual private network (VPN) to a PCS number. In this case, both a VPN feature process and a PCS feature process would be created.

Each feature process would determine if data was required at 1240. For example, a personal mobility feature process would need to access a database to locate the called party's current telephone number. If data is required at 1240, the service data center creates a service data manager at 1245. The data manager manages the data session and accesses the appropriate database at 1250. After the data is collected (or none is needed), the service is implemented by the feature process at 1255. For some features, i.e. 800 service, this may include route selection. The results of the feature process analysis are returned to the origination manager to assimilate. If the feature process does not provide the route, the origination manager must select the route using the local resource or another feature process.

The IAM itself contains numerous fields of information. The following table describes the elements of an IAM with regard to the information content and call processing.

TABLE 1

<u>Initial Address Message</u>	
Parameter Field Name	Description
<u>ROUTING LABEL</u>	
Service Indicator	Set a 0101-ISDN user part
Priority	0 or 1 based on destination
Network ID	10 for national network or set based on international trunk group
Destination Point Code	Destination of IAM

TABLE 1-continued

<u>Initial Address Message</u>	
Parameter Field Name	Description
5 Originating Point Code	Origination of IAM
Signaling Link Connection	Link used for messages (same for all messages for the call)
Circuit ID Code	Circuit used for the call between OPC and DPC in the IAM
10 Message Type	0000 or 0001 for IAM
<u>NATURE OF CONNECTION INDICATORS</u>	
Satellite Indicator	Increment for each satellite used
Continuity Check Indicator	00 -- no check 01 -- set up check and start COT timer 10 -- start timer for COT message.
15 Echo Suppressor Indicator	Indicates if echo control already implemented or is set if echo control is implemented
<u>FORWARD CALL INDICATORS</u>	
20 National/International Call Indicator	0 for domestic 1 for international
End to End Method Indicator	Pass any information
Interworking Indicator	Pass any information
IAM Segmentation Indicator	0 for POTS
ISDN User Part Indicator	Pass any information
25 ISDN Preference Indicator	Pass any information and default to 00
ISDN Access Indicator	Pass any information
SCCP Method Indicator	00
<u>CALLING PARTIES CATEGORY</u>	
30 Calling Party Category	00000000 for unknown 00001010 for ordinary caller 00001101 for test call
<u>USER SERVICE INFORMATION</u>	
Information Transfer Capability	Pass any information unless destination requires particular settings, but always pass ISDN "unrestricted digital information"
Coding Standard	00
Extension	1
Information Transfer Rate	Pass any information (will be 10000 for POTS)
40 Transfer Mode	Set at 00 for 64 kbit/sec
Extension	1
User Layer Protocol Identification	Set based on rate adaption, typically 0100010 for user information layer 1
Extension	1 for normal calls 0 for rate adaption
45 Rate	Nothing for user information layer 1, but 0111 for other rate adaption
Extension	1
<u>CALLED PARTY NUMBER</u>	
50 Nature of Address Indicator	Identifies the type of call: 0000001 -- original NPA or 950 call 0000011 -- 1+ call 0000100 -- direct dial international call 1110001 -- operator call 1110010 -- operator default 1110011 -- international operator call 1110100 -- long distance operator call 1110101 -- cut through call 1110110 -- 950, hotel/motel, or non equal access call 1110111 -- test call
60 Odd/Even Numbering Plan	number of digits in a called number 000 -- default 001 -- for ISDN 101 -- private
Digits Field	number of the called party
<u>ACCESS TRANSPORT</u>	
65 Access Transport Elements	pass any information

TABLE 1-continued

<u>Initial Address Message</u>	
Parameter Field Name	Description
<u>CALLING PARTY NUMBER</u>	
Nature of Address Indicator	indicates the type of calling party address, unique numbers can be used for billing, but the charge number is used for non-unique numbers; 0000000 -- unknown 0000001 -- unique caller number 0000011 -- unique national number 0000100 -- unique international number 1110001 -- non-unique caller number 1110011 -- non-unique national number 1110100 -- non-unique international number 1110111 --test call
Odd/Even	Number of digits in the calling number
Screening	Not applicable
Presentation Allowed/ Restricted	Pass any information for POTS, but restrict for N00 calls that are not allowed
Numbering Plan	000 -- default 001 -- ISDN 101 -- private
Digits Field	Number of the calling party
<u>CARRIER IDENTIFICATION</u>	
Network Identification Plan	Number of digits in identification code for the requested carrier
Type of Network Identification	Identifies the network numbering plan for the call -- 010 for POTS call from LEC
Digit One	First digit in carrier identification code
Digit Two	Second digit in carrier identification code
Digit Three	Third digit in carrier identification code
Digit Four or Null	Fourth digit in carrier identification code (if there are four digits)
<u>CARRIER SELECTION INFORMATION</u>	
Carrier Selection Indicator	Indicates whether the carrier identification code was presubscribed or input
<u>CHARGE NUMBER</u>	
Nature of Address Indicator	This information may be used for billing. 00000001 -- caller number 00000010 -- no ANI, route to operator 00000011 -- caller's national number 00000101 -- route if 800, or route to operator 000011 -- no ANI 00001111 route if 800 or route to operator
Odd/Even	Number of digits in calling number
Numbering Plan	Pass any information
Digits Field	The number of calling party
<u>GENERIC ADDRESS</u>	
Nature of Address Indicator	Pass any information
Odd/Even	Pass any information
Screening	Pass any information
Presentation Allowed/ Restricted	Pass any information
Numbering Plan	Pass any information
Digits Field	Pass any information
<u>ORIGINATING LINE INFORMATION</u>	
Originating Line Information	Identifies particular types of calls, for example: 00000000 -- normal call 00000111 -- call from a restricted phone 00111111 -- call from a cellular roamer
<u>ORIGINAL CALLED NUMBER</u>	
Nature of address Indicator	Pass any information
Odd/Even	Pass any information
Screening	Pass any information
Presentation Allowed/ Restricted	Pass any information
Numbering Plan	Pass any information

TABLE 1-continued

<u>Initial Address Message</u>	
Parameter Field Name	Description
<u>REDIRECTING NUMBER</u>	
Digits Field	Pass any information
Nature of Address Indicator	Pass any information
10 Odd/Even	Pass any information
Screening	Pass any information
Presentation Allowed/ Restricted	Pass any information
Numbering Plan	Pass any information
Digits Field	Pass any information
<u>REDIRECTION INFORMATION</u>	
15 Redirection Indicator	Pass any information
Original Redirecting Reason	Pass any information
Redirection Counter	Pass any information
Redirection Reason	Pass any information
<u>SERVICE CODE</u>	
20 Service Code	Pass any information
<u>TRANSIT NETWORK SELECTION</u>	
Network Identification Plan	Identifies the number of digits in the carrier identification code (3 or 4)
25 Type of Network Identification	Type of network identification for transit network parameter
Digits 1, 2, 3, 4	Carrier identification code of the international transit carrier
Circuit Code	Indicates how the call was dialed: 0001 -- international call no operator requested 0010 -- international call, operator requested
<u>HOP COUNTER</u>	
35 Hop Counter	limits the number of times an IAM may transfer through a signaling point. If the count reaches the limit, release the call

Subsequent ISUP Message Processing

40 The processing of the IAM is discussed above. Those skilled in the art are will appreciate how other SS7 messages can be incorporated into the processing of the present invention. For example, the time an address complete message (ACM) is received is recorded in the call control block for billing and maintenance. Triggers can also be based on receipt of subsequent messages, such as the ACM. The process for the answer message (ANM) is much the same.

45 Cut-through is the time point at which the users are able to pass information along the call connection from end to end. Messages from the CCM to the appropriate network elements are required to allow for cut-through of the call. Typically, call connections include both a transmit path from the caller and a receive path to the caller, and cut through is allowed on the receive path after the ACM is received and on the transmit path after the ANM is received.

50 Upon receipt of a release (REL) message, the CCM will write a time for the message to the call control block and check for triggers upon release (such as call re-originate). Additionally, any disabled echo canceller will be re-enabled, and the call control block will be used to create a billing record. Upon the receipt of a release complete message (RLC), the CCM will transmit messages directing tear down of the call path. It will clear its call specific processes and reuse the call connections for subsequent calls.

60 Additionally, suspend messages (SUS) and pass along messages (PAM) may be processed by the CCM. A suspend

US 6,298,064 B1

23

message (SUS) indicates that the called party has disconnected and a REL will follow if the called party does not re-connect with a specified time. APAM is simply a message between signaling points and can contain a variety of information and be used for a variety of purposes.

The invention allows switching over an ATM fabric on a call by call basis. This allows efficient high capacity virtual connections to be exploited. Advantageously, the invention does not require signaling capability in an ATM switch. The invention does not require call processing capability in an ATM switch. This enables networks to implement ATM switching without these sophisticated ATM switches that support high volumes of calls. It also avoids the cost of these switches. The invention fully supports voice traffic and non-voice traffic. The invention supports services, such as NOO, VPN, personal/terminal mobility, and voice messaging without requiring the service capability in an ATM switch. Relying on ATM cross-connects is advantageous because ATM cross-connects are farther advanced than ATM switches, and the cross-connects require less administrative support.

Those skilled in the art will appreciate that variations from the specific embodiments disclosed above are contemplated by the invention. The invention should not be restricted to the above embodiments, but should be measured by the following claims.

I claim:

1. A communication method for a call comprising:
receiving set-up signaling associated with the call into a processing system;
processing the set-up signaling in the processing system to select a DS0 connection;
generating a message identifying the DS0 connection;
transmitting the message from the processing system;
receiving the message and an asynchronous communication associated with the call into an interworking unit;
in the interworking unit, converting the asynchronous communication into a user communication; and
transferring the user communication from the interworking unit to the DS0 connection in response to the message.
2. The method of claim 1 wherein transferring the user communication comprises transferring a voice communication.
3. The method of claim 1 wherein processing the set-up signaling in the processing system to select the connection comprises processing the set-up signaling in the processing system to select a trunk group.
4. The method of claim 1 wherein receiving the asynchronous communication comprises converting the asynchronous communication from an optical signal to an electrical signal.
5. The method of claim 1 wherein transferring the user communication comprises converting the user communication from an electrical signal to an optical signal.
6. The method of claim 1 wherein the asynchronous communication is in asynchronous transfer mode.
7. The method of claim 1 wherein the processing system is external to telecommunication switches.
8. The method of claim 1 wherein receiving and processing the set-up signaling to select the connection comprises receiving and processing an initial address message to select the connection.
9. The method of claim 1 wherein receiving and processing the set-up signaling to select the connection comprises receiving and processing a called number to select the connection.

24

10. The method of claim 1 wherein receiving and processing the set-up signaling to select the connection comprises receiving and processing a caller number to select the connection.

11. The method of claim 1 wherein processing the set-up signaling in the processing system to select the connection comprises accessing a service control point.

12. The method of claim 1 wherein processing the set-up signaling in the processing system to select the connection comprises executing a Call Control Function (CCF) and a Service Switching Function (SSF).

13. The method of claim 1 wherein processing the set-up signaling in the processing system to select the connection comprises accessing a remote node that executes a Service Control Function (SCF).

14. The method of claim 1 wherein processing the set-up signaling in the processing system to select the connection comprises validating a call.

15. The method of claim 1 wherein processing the set-up signaling in the processing system to select the connection comprises screening a call.

16. The method of claim 1 wherein processing the set-up signaling in the processing system to select the connection comprises routing a call.

17. The method of claim 1 wherein processing the set-up signaling in the processing system to select the connection comprises processing the set-up signaling for an NOO service.

18. The method of claim 1 wherein processing the set-up signaling in the processing system to select the connection comprises processing the set-up signaling for a mobility service.

19. The method of claim 1 wherein processing the set-up signaling in the processing system to select the connection comprises processing the set-up signaling for a virtual network service.

20. The method of claim 1 wherein processing the set-up signaling in the processing system to select the connection comprises processing the set-up signaling for a voice messaging service.

21. The method of claim 1 wherein processing the set-up signaling in the processing system to select the connection comprises selecting the connection based on a translation of a called number.

22. The method of claim 1 wherein processing the set-up signaling in the processing system to select the connection comprises selecting the connection based on network loads.

23. The method of claim 1 wherein processing the set-up signaling in the processing system to select the connection comprises selecting the connection based on destination conditions.

24. The method of claim 1 further comprising storing data for the user communication identifying an originating carrier, originating circuit, the connection, caller number, called number, originating line set-up signaling, and echo cancellation status.

25. The method of claim 1 further comprising storing data for the communication identifying receipt times for an answer message and a release message.

26. The method of claim 1 further comprising processing the set-up signaling in the processing system to generate an initial address message.

27. The method of claim 1 further comprising:
processing the set-up signaling in the processing system to generate an echo cancellation instruction;
transmitting the echo cancellation instruction from the processing system;

US 6,298,064 B1

25

receiving the echo cancellation instruction into the interworking unit; and

in the interworking unit, canceling echo from the asynchronous communication in response to the echo cancellation instruction.

28. The method of claim 1 further comprising:

processing the set-up signaling in the processing system to generate an encryption instruction;

transmitting the encryption instruction from the processing system;

receiving the encryption instruction into the interworking unit; and

in the interworking unit, decrypting the asynchronous communication in response to the encryption instruction.

29. The method of claim 1 further comprising:

processing the set-up signaling in the processing system to generate a compression instruction;

transmitting the compression instruction from the processing system;

receiving the compression instruction into the interworking unit; and

in the interworking unit, decompressing the asynchronous communication in response to the compression instruction.

30. The method of claim 1 further comprising:

processing the set-up signaling in the processing system to generate a decibel level instruction;

transmitting the decibel level instruction from the processing system;

receiving the decibel level instruction into the interworking unit; and

in the interworking unit, adjusting a decibel level of the user communication in response to the decibel level instruction.

31. The method of claim 1 further comprising:

processing the set-up signaling in the processing system to generate a DTMF tone detection instruction;

transmitting the DTMF tone detection instruction from the processing system;

receiving the DTMF tone detection instruction into the interworking unit; and

in the interworking unit, detecting a DTMF tone from the asynchronous communication in response to the DTMF tone detection instruction.

32. The method of claim 1 further comprising:

processing the set-up signaling in the processing system to generate a message instruction;

transmitting the message instruction from the processing system;

receiving the message instruction into the interworking unit; and

in the interworking unit, playing a message in response to the message instruction.

33. The method of claim 1 further comprising:

receiving and processing an answer message in the processing system to generate a cut-through instruction;

transmitting the cut-through instruction from the processing system;

receiving the cut-through instruction into the interworking unit; and

in the interworking unit, cutting-through the call in response to the cut-through instruction.

26

34. The method of claim 1 further comprising:

receiving and processing a release message in the processing system to generate a termination instruction; transmitting the termination instruction from the processing system;

receiving the termination instruction into the interworking unit; and

in the interworking unit, terminating the call in response to the termination instruction.

35. A communication system for a call comprising:

a processing system configured to receive set-up signaling associated with the call, process the set-up signaling to select a DS0 connection, generate a message identifying the DS0 connection, and transfer the message; and an interworking unit configured to receive the message and an asynchronous communication for the call, convert the asynchronous communication into a user communication, and transfer the user communication to the DS0 connection in response to the message.

36. The communication system of claim 35 wherein the user communication comprises a voice communication.

37. The communication system of claim 35 wherein the processing system is configured to process the set-up signaling to select a trunk group.

38. The communication system of claim 35 wherein the interworking unit is configured to convert the user communication from an electrical signal to an optical signal.

39. The communication system of claim 35 wherein the interworking unit is configured to convert the asynchronous communication from an optical signal to electrical an signal.

40. The communication system of claim 35 wherein the asynchronous communication is in asynchronous transfer mode.

41. The communication system of claim 35 wherein the processing system is external to telecommunication switches.

42. The communication system of claim 35 wherein the set-up signaling comprises an initial address message.

43. The communication system of claim 35 wherein the processing system is configured to process a called number in the set-up signaling to select the connection.

44. The communication system of claim 35 wherein the processing system is configured to process a caller number in the set-up signaling to select the connection.

45. The communication system of claim 35 wherein the processing system is configured to access a service control point to select the connection.

46. The communication system of claim 35 wherein the processing system is configured to execute a Call Control Function (CCF) and a Service Switching Function (SSF).

47. The communication system of claim 35 wherein the processing system is configured to access a remote node that executes a Service Control Function (SCF).

48. The communication system of claim 35 wherein the processing system is configured to process the set-up signaling to validate a call.

49. The communication system of claim 35 wherein the processing system is configured to process the set-up signaling to screen a call.

50. The communication system of claim 35 wherein the processing system is configured to process the set-up signaling to route a call.

51. The communication system of claim 35 wherein the processing system is configured to process the set-up signaling for an N00 service.

52. The communication system of claim 35 wherein the processing system is configured to process the set-up signaling for a mobility service.

US 6,298,064 B1

27

53. The communication system of claim 35 wherein the processing system is configured to process the set-up signaling for a virtual network service.

54. The communication system of claim 35 wherein the processing system is configured to process the set-up signaling for a voice messaging service.

55. The communication system of claim 35 wherein the processing system is configured to process the set-up signaling to select the connection based on a translation of a called number.

56. The communication system of claim 35 wherein the processing system is configured to process the set-up signaling to select the connection based on network loads.

57. The communication system of claim 35 wherein the processing system is configured to process the set-up signaling to select the connection based on destination conditions.

58. The communication system of claim 35 wherein the processing system is configured to store data for the communication identifying an originating carrier, originating circuit, the connection, caller number, called number, originating line set-up signaling, and echo cancellation status.

59. The communication system of claim 35 wherein the processing system is configured to store data for the communication identifying receipt times for an answer message and a release message.

60. The communication system of claim 35 wherein the processing system is configured to process the set-up signaling to generate an initial address message.

61. The communication system of claim 35 wherein: the processing system is configured to process the set-up signaling to generate and transmit an echo cancellation instruction; and

the interworking unit is configured to receive the echo cancellation instruction and cancel echo from the asynchronous communication in response to the echo cancellation instruction.

62. The communication system of claim 35 wherein: the processing system is configured to process the set-up signaling to generate and transmit an encryption instruction; and

the interworking unit is configured to receive the encryption instruction and decrypt the asynchronous communication in response to the encryption instruction.

28

63. The communication system of claim 35 wherein: the processing system is configured to process the set-up signaling to generate and transmit a compression instruction; and

the interworking unit is configured to receive the compression instruction and decompress the asynchronous communication in response to the compression instruction.

64. The communication system of claim 35 wherein: the processing system is configured to process the set-up signaling to generate and transmit a decibel level instruction; and

the interworking unit is configured to receive the decibel level instruction and adjust a decibel level in the user communication in response to the decibel level instruction.

65. The communication system of claim 35 wherein: the processing system is configured to process the set-up signaling to generate and transmit a DTMF tone detection instruction; and

the interworking unit is configured to receive the DTMF tone detection instruction and detect a DTMF tone in the asynchronous communication in response to the DTMF tone detection instruction.

66. The communication system of claim 35 wherein: the processing system is configured to process the set-up signaling to generate and transmit a message instruction; and

the interworking unit is configured to receive the message instruction and play a message in response to the message instruction.

67. The communication system of claim 35 wherein: the processing system is configured to receive and process an answer message to generate and transmit a cut-through instruction; and

the interworking unit is configured to receive the cut-through instruction and cut-through the call in response to the cut-through instruction.

68. The communication system of claim 35 wherein: the processing system is configured to receive and process a release message to generate and transmit a termination instruction; and

the interworking unit is configured to receive the termination instruction and terminate the call in response to the termination.

* * * * *