

**IN THE UNITED STATES DISTRICT COURT
FOR THE DISTRICT OF KANSAS**

HIGH POINT SARL,)
)
Plaintiff and Counterclaim-Defendant,)
)
v.)
)
SPRINT NEXTEL CORPORATION, et al.,)
)
Defendants and Counterclaimants.)
)
)

Case No. 09-02269-CM

MEMORANDUM AND ORDER

Plaintiff asserts that defendants infringe four United States patents¹ directed to a cellular code division multiple access (“CDMA”) telephone network and other wireless networks. After extensive briefing and argument on claim construction, Special Master Karl Bayer submitted a report and recommendation regarding his proposed constructions for the disputed claim terms (Doc. 722) (“R&R”).²

Each side submitted objections to the R&R. The court analyzed the patents, the technology tutorial transcript and slides, the numerous briefs, the claim construction transcript, the R&R, and each party’s objections to the R&R. Based on a *de novo* review, the court provides its claim construction ruling.

I. Technology Overview³

¹ The asserted patents include: (1) U.S. Patent No. 5,195,090 (“the ‘090 Patent”); (2) U.S. Patent No. 5,305,308 (“the ‘308 Patent”); (3) U.S. Patent No. 5,184,347 (“the ‘347 Patent”); and (4) U.S. Patent No. 5,195,091 (“the ‘091 Patent”).

² The court genuinely appreciates Special Master Bayer’s assistance with claim construction. His R&R was thoughtful and very well written. He did a nice job identifying the relevant issues, researching the applicable law, and providing a succinct analysis and recommendation.

³ The technology overview is not binding but is provided for context.

Cellular mobile telephone networks allow mobile telephone users to connect to the traditional land-based public telephone network, called the Public Switched Telephone Network (“PSTN”). Once connected to the PSTN, the call can be routed to any land-line telephone in the world or to any other mobile user connected to the PSTN.

The components of a typical mobile phone network include the mobile unit, a base station (or cell), a switching system, and the PSTN. The mobile unit sends call traffic over the air to a base

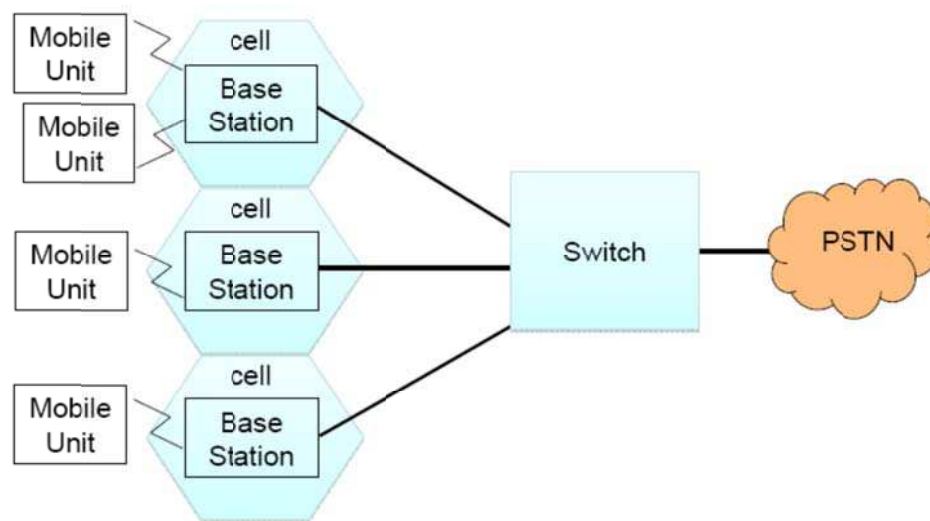

station by means of radio waves. This is the “air interface.” The remainder of the system is the “terrestrial infrastructure.” The patents discuss a way to design and implement the terrestrial infrastructure.

II. Legal Standards

This court’s claim construction analysis is guided by the Federal Circuit’s en banc opinion in *Phillips v. AWH Corp.*, 415 F.3d 1303 (2005). In that opinion, the Federal Circuit reiterated that claim terms are given their plain and ordinary meaning, which is “the meaning that the term would have to a person of ordinary skill in the art in question at the time of the invention, i.e., as of the effective filing date of the patent application.” *Id.* at 1313. To determine how a person of ordinary skill in the art would understand a claim term, courts look to several sources including “the words of the claims

themselves, the remainder of the specification, the prosecution history, and extrinsic evidence concerning relevant scientific principles, the meaning of technical terms, and the state of the art.” *Id.* at 1314.

In discussing these sources, the Federal Circuit explained that the claims themselves provide “substantial guidance as to the meaning of particular claim terms.” *Id.* Moreover, the other claims in the patent—both asserted and unasserted—can be valuable sources regarding the meaning of a claim term. *Id.* Despite the primacy of the claim language, the specification “is always highly relevant to the claim construction analysis” and “is the single best guide to the meaning of a disputed term.” *Id.* But the Federal Circuit has “expressly rejected the contention that if a patent describes only a single embodiment, the claims of the patent must be construed as being limited to that embodiment.” *Id.* at 1323. The prosecution history also helps demonstrate how the inventor understood the patent and whether the inventor limited the scope of the claims to obtain his patent. *Id.* at 1317.

Some claim terms are written in means-plus-function (“MPF”) format. This claiming format is allowed and defined by 35 U.S.C. § 112, ¶ 6, which allows an inventor to draft a claim in functional terms rather than defining the structural elements or components that accomplish the function. Claim elements that employ the word “means” are presumed to be in MPF format, and claim terms that do not include the word “means” are presumed to not be in MPF format. Construction of a MPF claim term involves two steps. *Applied Med. Res. Corp. v. U.S. Surgical Corp.*, 448 F.3d 1324, 1332 (Fed. Cir. 2006). First, the function must be identified. *Id.* Second, the structure in the specification that accomplishes the claimed function must be identified. *Id.*

III. Terms In Standard Format

The parties dispute multiple claim terms that are in standard claim format. The court addresses each term and the corresponding objections.

A. “TDM Communications Link Interface” and “Packet Communications Link Interface”

Neither party objects to the recommended constructions for these terms. And, after an independent review, the court agrees with the analysis in the R&R. Accordingly, the court determines that **“time-division-multiplexed (TDM) communications link interface”** means **“an interface which sends and/or receives time-division multiplexed traffic”** and that **“packet communications link interface”** means **“an interface which sends and/or receives packets.”**

B. “Switching System”

Sprint objects to the recommended construction for this term on the grounds of legal error. Specifically, Sprint argues that the R&R adopts the construction “closest” to the correct construction instead of declaring the correct construction. Doc. 747 at 31. Sprint proposes that the correct construction is “elements that are needed to switch digital traffic originating from or destined for a cell.” *Id.*

Sprint is correct that the court is obligated to declare the meaning of claim terms. *See Exxon Chem. Patents, Inc. v. Lubrizol Corp.*, 64 F.3d 1553, 1556 (Fed. Cir. 1995) (explaining that the judge must “declare the meaning of the claims” and not simply decide “which of the adversaries is correct”). Although the R&R might have inartfully used the word “closest,” it is clear to this court that the Special Master carefully reviewed the law and evidence, concluded that Sprint’s proposed construction was incorrect, and determined that High Point’s construction was correct.

In addition, the court’s independent review of the evidence further confirms that the proposed construction is correct. The claim language indicates that this term is a broad term and that there may be more than one switching system. *See, e.g.*, ‘090 Patent at 48:44 (“at least one switching system”). The claim context also indicates that the switching system includes the components that switch digital traffic. This understanding of the claim context is reinforced by the technical definition of “switching

system.” And both experts agree that this technical definition embodies the ordinary meaning of the word. Accordingly, the court overrules Sprint’s objection and determines that **“switching system”** means **“components of a mobile telecommunications network that switch digital traffic originating from or destined for a cell.”**

C. “Fluctuating Transmission Delay” and/or “Phase . . . Fluctuating”

Sprint objects to the proposed constructions for these terms and argues that the negative limitations proposed by Sprint are required by prosecution history estoppel. These terms appear in two related applications, and the same examiner reviewed both applications. The patent examiner rejected both applications under 35 U.S.C. § 101 for claiming the same invention. In responding to these objections, the patentee made the following statements:

Consequently, a system may have only one of the two sources of asynchrony enumerated in the two applications: either a transmission medium having a fluctuating transmission delay (the subject of the other application), or fluctuations between clock signals (the subject of this application).

Further, applicants’ attorney pointed out that the claims of the two applications explicitly distinguish in their recitations between these two sources of asynchrony. Each independent one of the claims 3-23 and 26-46 of this application recites that the first unit is timed by clock signals that have a phase different from and fluctuating with respect to clock signals that time the second unit, and do not have any recitations directed to the transmission medium. In contrast, each independent one of the claims of the other application recites a communications medium that has a fluctuating transmission delay, and recite the first and second units to be clocked by same-frequency clock signals. Consequently, the claims of the two applications clearly distinguish between which one of the two sources of asynchrony must be present for the claims to apply. Clearly, then, the claims of the two applications are directed to two independent and distinct inventions.

Doc. 627-12 at 3 (emphasis in original).

Sprint’s prosecution history estoppel argument focuses on the last sentence, where the patentee described the claims of the two applications as directed to “independent” inventions. Specifically, Sprint argues—based on an opinion of the Court of Customs and Patent Appeals—that “independent and distinct inventions” means that there is “no overlap in claim scope”

between the claims of the two applications. Doc. 747 at 33 (relying on *Application of Schneller*, 397 F.2d 350, 354–55 (C.C.P.A. 1968)). Therefore, to honor this disclaimer, Sprint argues that the construction for these claim terms must include the following negative limitations: “not due to clock drift” for the former and “not due to transmission delay” for the latter.

The court disagrees with Sprint’s argument because it focuses on a single word and not the overall context of the office action. The body of the argument explains that the claims of the two different inventions are designed to correct the operations of two devices that could become asynchronous due to different causes. The claims in each application then distinguish between which one of the two sources of asynchrony must be present for the claims to apply. Requiring a source of asynchrony to be present, however, does not mean that other sources of asynchrony cannot be present—particularly because the relevant claims are open ended.

The court agrees that the public has the right to rely on statements made during prosecution. But a member of the public reading this office action would not emphasize a single phrase to the exclusion of the rest of the office action—especially when emphasizing the single phrase and ignoring the context results in the claims not covering any disclosed embodiment. *See On-Line Techs., Inc. v. Bodenseewerk Perkin-Elmer GmbH*, 386 F.3d 1133, 1138 (Fed. Cir. 2004) (“[A] claim interpretation that excludes a preferred embodiment from the scope of the claim is rarely, if ever, correct.”). The court also rejects Sprint’s argument regarding the inclusion of “data” in the construction. Neither of the prosecution history statements represents the clear and unmistakable disavowal of claim scope required by the Federal Circuit. *Omega Eng’g, Inc. v. Raytek Corp.*, 334 F.3d 1314, 1325–26 (Fed. Cir. 2003) (“[F]or prosecution disclaimer to attach, our precedent requires that the alleged disavowing actions or statements made during prosecution be both clear and unmistakable.”).

The court overrules Sprint's objections and construes "fluctuating transmission delay" to mean "a delay in transmission of data that varies over time due at least in part to the path on which the data is sent" and "phase . . . fluctuating" to mean "a phase that varies over time due at least in part to clock drift."

D. "Call-Handling Module" and "Interface Arrangement"

Sprint objects to both recommended constructions and argues that these terms are in MPF format. Specifically, Sprint argues that "call-handling module" is a functional limitation that accomplishes 8 functions and lacks corresponding structure (rendering the claim invalid).⁴ Similarly, Sprint argues that "interface arrangement" is a functional limitation that accomplishes 14 functions and lacks corresponding structure (likewise rendering the claim invalid).⁵

These terms do not include the word "means" and, therefore, are presumed to not be in MPF format. *Personalized Media Comm'ns, LLC v. Int'l Trade Comm'n*, 161 F.3d 696, 703–04 (Fed. Cir. 1998). Sprint can rebut this heavy presumption if the intrinsic and extrinsic evidence so warrant. *Id.* at 704. In determining whether Sprint rebuts this presumption, "the focus remains on whether the claim as properly construed recites sufficiently definite structure to avoid the ambit of [35 U.S.C.] § 112, ¶ 6." *Id.*

The court agrees with the R&R that Sprint has not rebutted the presumption. As an initial point, there are several aspects of Sprint's proffered constructions that are concerning to the court. As one example, Sprint's proposed function for "interface arrangement" constitutes the entire claim minus

⁴ Sprint argues that claim 54 of the '090 Patent assigns eight functions to the call-handling module. Sprint acknowledges that the call-handling module is the structure that performs these functions but argues that call-handling module is a "nonce" term that does not identify any specific structure for performing the recited functions.

⁵ Sprint argues that claim 40 of the '347 Patent recites a cellular-radio telephone system that includes three components: (1) the arrangement, (2) at least one cell, and (3) a mobile-telephone switching system. Based on Sprint's reading of the claim, the entire method occurs in the arrangement. Sprint further argues that the specification fails to disclose any corresponding structure because the patent only discloses that the interface arrangement is inside (versus distinct from) the switching system.

the preamble. As another example, both of Sprint’s proposed functions repeatedly include the term to be construed (e.g., “receiving from a link at a call-handling module first packets . . .”). Such constructions seem redundant and would be difficult for a jury to apply.

Regardless, the court determines that “module” and “interface” are a sufficient recitation of structure to avoid 35 U.S.C. § 112, ¶ 6. Contrary to Sprint’s argument, neither term is a nonce term or a coined term that lacks a clear meaning. Rather, both terms have a well-known meaning to those of skill in the art. *See Stanacard, LLC v. Rebtel Networks, AB*, 680 F. Supp. 2d 483, 498 (S.D.N.Y. 2010) (“Numerous cases demonstrate that the term ‘module,’ in the context of the telecommunications field, denotes sufficient structure such that § 112, ¶ 6 does not apply.”); *see also* IEEE Dictionary (“interface”) (5th ed. 1993) (defining “interface” as “a hardware or software component that connects two or more other components for the purpose of passing information from one to the other”). Moreover, the fact that these terms do not connote a specific physical structure does not detract from the definiteness of the term. Instead, it is sufficient that these terms convey to one of skill in the art a variety of structures known as “modules” and “interfaces.” *See Semitool, Inc. v. Novellus Sys.*, 44 F. App’x 949, 956 (Fed. Cir. 2002) (determining that “wafer support” conveys sufficient structure to preclude the application of 35 U.S.C. § 112, ¶ 6 and explaining that “[t]he fact that the term ‘support’ does not specifically evoke a particular structure does not change that fact that it does connote structure”).

Because Sprint fails to rebut the presumption against MPF treatment, the court applies the traditional claim construction analysis to both terms. After an independent review of the intrinsic and extrinsic evidence, the court agrees with the proposed construction for both terms. Accordingly, the court determines that “**call-handling module**” means “**an assembly of interconnected components which processes incoming and outgoing call traffic**” and “**interface arrangement**” means “**an**

arrangement of interconnections between components of a wireless telecommunications network that synchronize the routing of call traffic between a cell and the source or destination of the call.”

E. “In Response To . . . Incoming” and “In Response To . . . Outgoing . . .”

Sprint objects to the recommended construction on grounds of legal error. Specifically, Sprint argues that this term is in step-plus-function (“SPF”) format. According to Sprint, the claim limitation is not merely transmitting packets. Rather, the claim requires transmitting packets in statistically multiplexed form. And statistical multiplexing is a function that is the result of several acts that are not recited in the claim. *See* 8-18-2011 Tr. at 491–96 (outlining Sprint’s position).

The court understands Sprint’s argument as well as Sprint’s concern that High Point is attempting to read “statistical multiplexing” out of every claim element. *Id.* at 554. But the court does not agree that statistical multiplexing is a function of this claim element. Simply because the packets are transmitted in “statistically-multiplexed form” does not mean that statistical multiplexing is a function of this claim term. Rather, the inclusion of statistically-multiplexed form is describing what is being transmitted.

In addition, the Federal Circuit has instructed that 35 U.S.C. § 112, ¶ 6 does not apply “without a showing that the limitation contains nothing that can be construed as an act.” *Masco Corp. v. United States*, 303 F.3d 1316, 1327 (Fed. Cir. 2002). Here, the claim element includes an act—namely transmitting packets. *See id.* (explaining that “transmitting a force” is not in SPF format).

Accordingly, the court determines that this claim element is not in SPF format. The court also agrees for the reasons in the R&R that these terms do not require additional construction. The court overrules Sprint’s objection and determines that these claim terms should be given their **plain and ordinary meaning**.

F. Third Unit / Third Operating Unit

The R&R determines that this term is in MPF format and recommends a function and corresponding structure. High Point objects to the Special Master's conclusion that this term is in MPF format. Like the terms previously considered, this claim element does not use the word "means." Therefore, Sprint has to overcome the presumption against MPF claiming.

The relevant claim language is: "a third unit for interfacing communications between the first and the second units" and "a third operating unit for interfacing the operations of the first unit with the operations of the second unit." Based on this language, the function for each term is easily discernible: "interfacing communications between the first and second units" and "interfacing the operations of the first unit with the operations of the second unit," respectively.

The issue becomes whether "third unit" and "third operating unit" connote sufficiently definite structure. The court determines that they do not. The term "unit" is a generic term, and the adjective "third" does not provide any generally understood structural meaning. *See Welker Bearing Co. v. PHD Inc.*, 550 F.3d 1090, 1096 (Fed. Cir. 2008) (determining that "mechanism for moving said finger" was a MPF limitation); *see also LG Elecs., Inc. v. Quanta Computer Inc.*, No. 07-cv-361-bbc, 2008 U.S. Dist. LEXIS 16669 at *4-5 (W.D. Wis. Mar. 4, 2008) (explaining that a "unit" could be "almost anything" and determining that "input unit," "recording unit," and "reproducing unit" were subject to construction under 35 U.S.C. § 112, ¶ 6). Accordingly, the court overrules High Point's objection and determines that "third unit" is in MPF format.

Although not the subject of a specific objection, the court also agrees with the recommended function and corresponding structure. Accordingly, these terms have the following function and corresponding structure:

Third Unit

Function: **Interfacing communications between the first and second units**

Structure: Clock circuit 600 for establishing a nominal frequency, adaptive synchronization circuit 611 and processor 602 programmed to control circuit 611 to change, as required, the timing of transmission or receipt signals at the first or second units so as to maintain the asynchrony between the first and second units within the prescribed window

Third Operating Unit

Function: Interfacing the operations of the first unit with the operations of the second unit

Structure: Clock circuit 600 for establishing a nominal frequency, adaptive synchronization circuit 611 and processor 602 programmed to control circuit 611 to change, as required, the timing of transmission signals at the first unit so as to maintain the asynchrony between the first and second units within the prescribed window

IV. Terms In MPF Format

The parties agree that the remaining terms are in MPF format and are governed by 35 U.S.C.

§ 112, ¶ 6. The court addresses each term below.

A. Claim 28 ('090 Patent)

There are two MPF terms in claim 28.

1. First Means

The relevant language is:

first means responsive to said radio reception of incoming voice call traffic from a plurality of the radio telephones, for statistically-multiplexing packets carrying the incoming call traffic of individual calls from the plurality of radio telephones, and responsive to receipt from a source of statistically-multiplexed packets carrying outgoing voice call traffic of the individual calls, for demultiplexing the received multiplexed packets for radio transmission of the outgoing traffic to the plurality of radio telephones[.]

'090 Patent at claim 28. Sprint objects to the recommended function and structure.

a) Function

Sprint argues that the recommended function should include the “responsive to” language.

After reviewing the claim language and relevant evidence, the court overrules Sprint’s objection on

this issue. The claim language indicates that the “responsive to” language is not describing the performed function. Rather, this language is describing the relationship between the first means and other claim elements. This understanding of the claim language is consistent with Federal Circuit case law explaining that the claimed function typically follows the word “for.” See *Micro Chem., Inc. v. Great Plains Chem. Co.*, 194 F.3d 1250, 1258 (Fed. Cir. 1999) (explaining that the function is “signaled by the preposition ‘for’”); *Rodime PLC v. Seagate Techs., Inc.*, 174 F.3d 1294, 1303 (Fed. Cir. 1999) (“The prepositional link ‘for’ ties the ‘means’ to its function.”). Also relevant to the court’s construction is the claim context. Specifically, the commas after “telephones” and “calls” indicate that the claim is beginning to recite the claimed functions.

Sprint also argues that the recommended construction essentially removes the “responsive to” limitation because High Point will argue that everything is responsive to said radio reception of incoming voice call traffic from a plurality of the radio telephones. That specific issue is not currently before the court, and the court does not express an opinion on it. Rather, the issue before the court is the proper construction for the “first means” limitation. And, for the reasons stated herein, the court determines that the “responsive to” language is not part of the function for that term. Sprint can address its concerns that High Point is improperly construing or applying the “responsive to” phrase either by seeking construction of the “responsive to” language or raising an invalidity argument.

The case law and office action amendment cited by Sprint do not alter the court’s conclusion. In the case cited by Sprint—*Mettler-Toledo, Inc. v. Fairbanks Scales Inc.*, 551 F. Supp. 2d 576, 596 (E.D. Tex. 2008)—the court did not engage in an analysis of the relevant issue because the parties agreed that the “responsive to” language was part of the function. Conversely, several cases identified by High Point analyze this issue and conclude that the “responsive to” language is not part of the function. See, e.g., *Alt v. Medtronic, Inc.* No. 2:04-cv-370, 2005 U.S. Dist. LEXIS 44928, at *13–14

(E.D. Tex. Nov. 30, 2005) (concluding that “responsive to” language “does not describe what function is performed, but rather how the function is performed”).⁶ The prosecution history statement identified by Sprint is also unpersuasive. In that office action response, the patentee is describing the role of the specification and the claims. It is not—contrary to Sprint’s argument—expressly stating that the function includes the “responsive to” language. Accordingly, the court overrules Sprint’s objection on this issue.

b) Structure

Based on this function, the R&R recommends that the corresponding structure is “cluster controller 244, including controller 393.” Sprint argues that the R&R “makes a fundamental legal error in omitting the algorithm” from the corresponding structure and a “fundamental factual error in assuming that ‘cluster controller 244 is a specialized device known to a person of ordinary skill in the art (“POSITA”) at the time of the invention.’” Doc. 747 at 17.

The initial issue before the court is whether a POSITA at the time of the invention would recognize cluster controller 244 as identifying a specialized device. This was a difficult issue, but the court answers this question in the negative. The court recognizes that there were devices at the time of the invention that were known as cluster controllers and did multiplexing. An example identified by High Point’s expert—but not identified in the specification—is IBM 3274. The IBM 3274 was available at the time of invention and connected terminals to a mainframe. But High Point did not identify a single available device that performed the claimed function. Indeed, High Point’s expert

⁶ Sprint argues that the district court in *Alt* construed the language between “means” and “for” as part of the function for another term in the patent. Doc. 627 at 28. The term Sprint is referring to is “[a]ctivity sensor means arranged and adapted to be implanted in the patient to respond to movements of the patient for conversion thereof into a rate determining signal to be applied to said rate selecting means.” In construing this term, the district court included the “to respond to” language in the function because (1) the specification indicated that the activity sensor must respond to movements of the patient first, before it can convert the movements into a rate determining signal, and (2) the claim does not use traditional MPF language because the “thereof” language refers back to the movement of the patient that the activity sensor responded to. *Alt*, 2005 U.S. Dist. LEXIS 44928, at *20–21. Similar circumstances are not present in this case.

concedes that “the particulars of cluster controller 244 and the manner in which it is used in the claimed inventions was not previously known[.]” 5-13-2011 Chandler Decl. at ¶ 20; *see also* 8-18-2011 Tr. at 667 (High Point’s expert agreeing that “the ones of ordinary skill in the art would not expect [the claimed functions] to be performed by existing cluster controllers”); *id.* at 733–34 (Sprint’s expert explaining that the known cluster controllers “were designed for completely different systems” and had “nothing to do with deterministic traffic, voice traffic, or anything else”).

The fact that the available cluster controllers did not perform the claimed functions indicates that a POSITA would not recognize cluster controller 244 as identifying a specialized device. *See* 8-18-2011 Tr. at 741 (Sprint’s expert concluding that “I don’t think anyone in the skill of the art would think they were the . . . same thing”). This conclusion is further supported by the specification because the specification does not treat cluster controller 244 as a reference to an available device. For example, unlike other components, the specification does not identify any specific examples of known cluster controllers nor does it indicate that cluster controllers were well known in the prior art. *See* ‘090 Patent at 18:5–6 (explaining that vocoders “are well known in the art”). In addition, the specification describes the components of cluster controller 244 and even includes figures showing the internal components of the cluster controller. ‘090 Patent at 11:54-12:19; *id.* at Fig. 2. One of these components is controller 393, which is described as a “general purpose microprocessor.” *Id.* at 11:60. And the parties agree that part of the claimed function occurs in this processor. *See, e.g.,* 8-18-2011 Tr. at 654 (explaining that statistical multiplexing is “software based”). The inclusion of these additional details—particularly the general-purpose microprocessor—indicates that the specification is not identifying a known specialized device. Rather, the specification is identifying a computer.

High Point argues that it is “irrelevant” that the available devices could not perform the claimed functions. To support this argument, High Point relies on the Federal Circuit’s opinion in *In*

re *Katz Interactive Call Processing Patent Litigation*, 639 F.3d 1303 (Fed. Cir. 2011). In that opinion, the Federal Circuit explained that “functions of ‘processing,’ ‘receiving,’ and ‘storing’ are coextensive with the structure disclosed, i.e., a general purpose processor.” *Id.* at 1316. By analogy, High Point argues that the function of “multiplexing” is coextensive with cluster controller and, therefore, an algorithm is not required.

The court does not find this argument persuasive. Since *Katz*, the Federal Circuit has explained that *Katz* represents a “narrow exception” and that “[i]t is only in the rare circumstances where any general-purpose computer without any special programming can perform the function that an algorithm need not be disclosed.” *Ergo Licensing, LLC v. CareFusion 303, Inc.*, 673 F.3d 1361, 1364–65 (Fed. Cir. 2012) (emphasis added). Here, the cluster controller identified by High Point did not perform the claimed function and the manner in which it is used in the claimed invention was not previously known. In addition, the function of statistical multiplexing packets is a principal feature of the invention. 8-17-2011 Tr. at 28. Therefore, the court determines that special programming would still be required.

Because cluster controller 244 is not identifying a specialized device, the court must determine the corresponding algorithm. *WMS Gaming Inc. v. Int’l Game Tech.*, 184 F.3d 1339, 1348–49 (Fed. Cir. 1999). The court determines that the algorithm proffered by High Point is correct. An algorithm may be expressed “in any understandable terms including as a mathematical formula, in prose . . . or in any other manner that provides sufficient structure.” *Finisar Corp. v. DirecTV Group, Inc.*, 523 F.3d 1323, 1340 (Fed. Cir. 2008). The algorithm identified by High Point is described in the specification and satisfies the *quid pro quo* for MPF claiming. ‘090 Patent at 13:30-55. Accordingly, the court sustains Sprint’s objection in part and determines that this term has the following function and corresponding structure:

Function: Statistically-multiplexing packets carrying the incoming call traffic of individual calls from the plurality of radio telephones, and demultiplexing the received multiplexed packets for radio transmission of the outgoing traffic to the plurality of radio telephones

Structure: Cluster controller 244, including controller 393, programmed to queue incoming traffic segments, format them into packets for transmission and transmit them one after the other into an allocated output pipe, and to deformat the outgoing packets and distribute the contents of the packets to the channel elements

2. Second Means

The relevant language is:

second means for informing the source how to adjust time instants of transmission from the source of the packets carrying the outgoing traffic to ensure receipt of the transmitted packets at the cell within predetermined windows of time[.]

‘090 Patent at claim 28. The parties agree on the claimed function—namely everything following the word “for.” But Sprint makes two objections.

First, Sprint argues that recommended construction reads “ensure” out of the claim. The basis for this argument is that “ensure” means “guarantee” and the corresponding structure does not guarantee particular timing. The court agrees that one meaning of “ensure” is “guarantee.” But the word “ensure” is susceptible to several other meanings. *See, e.g.*, Doc. 755 at 15 (outlining other uses of the word “ensure”). And the context of the claim and the specification indicate that the meaning advanced by Sprint is not correct. For example, the specification teaches that the packets may be received outside of the predetermined window and provides a mechanism for adjusting future transmission times. ‘090 Patent at Fig. 16; *id.* at column 18. The specification also instructs that the timing of receipt and transmission will be monitored throughout the call because additional corrections may need to be made. *Id.* Based on this intrinsic support, the court agrees with the R&R that the asserted claim does not create the “without fail” result urged by Sprint and overrules Sprint’s objection.

Second, Sprint argues that the recommended structure fails to include an algorithm. This objection is based on the argument that cluster controller 244 is not a specialized device. For the reasons articulated above (*see supra* IV(A)(1)(b)), the court agrees that cluster controller 244 is not a specialized device and that an algorithm is required. The court, however, disagrees with Sprint’s proposed algorithm. Instead, the court adopts the algorithm proposed by High Point because it discloses the necessary structure and allows a POSITA to understand the bounds of the invention. *See, e.g., AllVoice Computing PLC v. Nuance Commc’ns, Inc.*, 504 F.3d 1236, 1245 (Fed. Cir. 2007) (explaining that “algorithms in the specification need only disclose adequate defining structure to render the bounds of the claim understandable to one of ordinary skill in the art”). Accordingly, the court sustains Sprint’s objection in part construes the claimed function and corresponding structure as follows:

Function: Informing the source how to adjust time instants of transmission from the source of the packets carrying the outgoing traffic to ensure receipt of the transmitted packets at the cell within predetermined windows of time

Structure: Cluster controller 244, including controller 393, programmed to upon receipt of outgoing call traffic that arrives earlier or later than desired, the creation of a packet containing timing adjustment information for use by the source to bring receipt of future voice packets within predetermined time windows, and the transmission of the packet containing the timing adjustment information to the switching system

B. Claims 8, 10, 15, and 22 (‘090 Patent)

There are two MPF terms common to these four claims: “first means” and “second means.”

Each is addressed below.

1. First Means

The relevant claim language for all four claims is:

each cell including first means responsive to radio reception of incoming voice call traffic from radio telephones, for transmitting packets carrying the incoming traffic of individual calls on the connected at least one link in statistically-multiplexed form, and further for receiving packets carrying outgoing voice call traffic of the individual calls

on the connected at least one link in statistically-multiplexed form for radio transmission of the outgoing traffic to the radio telephones[.]

'090 Patent at claim 10. Sprint objects to the recommended function and structure.

a) Function

Similar to the above (*see supra* IV(A)(1)(a)), Sprint argues that the “responsive to” language should be part of the function. For substantially the same reasons, the court overrules this objection. Sprint also objects that the function should include the transformation of deterministic traffic to non-deterministic traffic (i.e., statistical multiplexing). Specifically, Sprint argues that the general construct of these claim terms is “means, responsive to the receipt of X, for transmitting Y” and requires the transformation of X to Y. Doc. 627 at 26. This argument rests on a similar premise as Sprint’s argument for “in response to . . . incoming” and “in response to . . . outgoing . . .” (*see supra* III(E)). And, for the same general reasons, the court finds it unconvincing. The “in statistically multiplexed form” is describing the type of packets that are transmitted but is not reciting an additional function. Indeed, as shown in claim 28, the patentee knew how to claim the function of statistical multiplexing but chose not to claim that function in these claims. Therefore, the court overrules these objections.

b) Structure

Sprint also objects to the recommended structure. Sprint argues that the corresponding structure should be the same for all four terms because the claimed function is the same. The R&R recommends that the corresponding structure for claims 8, 15, and 22 is DS1 interface 242 and the corresponding structure for claim 10 is DS1 interface 242, channel elements 245, and cluster controller 244, including controller 393. The R&R recommends a different structure for claim 10 because claim 10 expressly requires that “each first means include a plurality of channel elements . . . and third

means[.]” Sprint argues that the corresponding structure for all four claims should be the structure required for claim 10.

MPF claiming is authorized by 35 U.S.C. § 112, ¶ 6. This statute provides that “[a]n element in a claim for a combination may be expressed as a means or step for performing a specified function . . . and such claim shall be construed to cover the corresponding structure, material, or acts described in the specification and equivalents thereof.” Based on this statute, courts apply a two-step approach to construing MPF terms: (1) the court identifies the claimed function, and (2) the court identifies the structure in the specification that performs the claimed function. *Minks v. Polaris Indus.*, 546 F.3d 1364, 1377 (Fed. Cir. 2008). Here, the court determined the claimed function. And the evidence indicates that DS1 interface 242 is the structure that performs the claimed function. Accordingly, the court determines that the corresponding structure for all four claims is DS1 interface 242.

The court recognizes that claim 10 includes additional language that narrows the first means by requiring that the first means includes a plurality of channel elements and third means.⁷ This language has meaning because it constitutes narrowing limitations on the first means. But the briefing before the court does not provide a legal basis for adding corresponding structure that is unrelated to the claimed function. *See Laitram Corp. v. Rexnord, Inc.*, 939 F.2d 1533, 1538 (Fed. Cir. 1991) (explaining that judicially created doctrines cannot override the statutory requirements of 35 U.S.C. § 112, ¶ 6). Based on the law before it, the court disagrees with the recommended construction for several reasons.

First, the statute states that the claim shall be construed to cover “corresponding structure . . . described in the specification and equivalents thereof.” 35 U.S.C. § 112, ¶ 6. The R&R includes the additional structure for claim 10 because of the claim language and not because it is corresponding

⁷ The court has not been asked to construe “plurality of channel elements” and “third means.”

structure described in the specification.⁸ Second, the analysis for construing a MPF term requires the corresponding structure to be structure that performs the claimed function. *Minks*, 546 F.3d at 1377; *Asyst Techs., Inc. v. Empak, Inc.*, 268 F.3d 1364, 1371 (Fed. Cir. 2001) (excluding structure that enables but does not perform the claimed function); *Gemstar-TV Guide Int’l, Inc. v. Int’l Trade Comm’n*, 383 F.3d 1352, 1360–63 (Fed. Cir. 2004) (including structure because it performs claimed function). Here, neither party argues that the channel elements and third means perform the claimed function. Instead, both parties tacitly concede that the additional structure does not perform the claimed function. Third, the claimed function is the same for all four claims. Neither party argues that the additional language in claim 10 modifies the claimed function or incorporates additional functions. The court is unaware of case law that adopts different corresponding structure for identical functions in the same patent.

The court recognizes that this construction is not anticipated by either party and, therefore, it is unclear what overarching impact this construction has on the claims (e.g., it is unclear whether this construction excludes disclosed embodiments from the scope of claim 10).⁹ Despite the straightforward analysis articulated above, this issue was not directly addressed by either party. Therefore, the court may reconsider this construction if either party provides case law or analysis addressing the court’s concerns.¹⁰ But, based on the law and evidence before it, the court sustains in part Sprint’s objection and construes “first means” for all four claims as:

⁸ Neither party argues that the structure in claim 10 rebuts the MPF presumption.

⁹ This result could impact the interpretation of the claimed function.

¹⁰ The Supreme Court has explained that claim construction is not a purely legal matter but is rather a “mongrel practice” with “evidentiary underpinnings.” *Markman v. Westview Instruments*, 517 U.S. 370, 378, 390 (1996). Accordingly, this court may reconsider or modify any of these constructions if subsequent evidence compels an alternative construction. See *Pressure Prods. Med. Supplies v. Greatbatch Ltd.*, 599 F.3d 1308, 1316 (Fed. Cir. 2009) (concluding that it was proper for the trial court to supplement the definition of a claim term during trial); *Jack Guttman, Inc. v. Kopykake Enters., Inc.*, 302 F.3d 1352, 1361 (Fed. Cir. 2002) (“District courts may engage in a

Function: Transmitting packets carrying the incoming traffic of individual calls on the connected at least one link in statistically-multiplexed form, and receiving packets carrying outgoing voice call traffic of the individual calls on the connected at least one link in statistically-multiplexed form for radio transmission of the outgoing traffic to the radio telephones

Structure: DS1 interface 242

2. Second Means

The relevant language for all four claims is:

each switching system including second means responsive to receipt of outgoing voice call traffic destined for radio telephones served by a cell, for transmitting packets carrying the outgoing traffic of the individual calls in statistically-multiplexed form on the at least one link connected to the cell, and further for receiving packets carrying incoming voice call traffic of the individual calls in statistically-multiplexed form on the at least one line connected to the cell for transmission of the incoming traffic to destinations of the incoming traffic[.]

‘090 Patent at claim 10. Sprint objects to the recommended function and structure for substantially the same reasons it objected to “first means.” For the reasons explained above, the court overrules Sprint’s objections to the claimed function. Sprint also objects to the recommended structure and argues that the structure for all four claims should be the same. The court agrees with Sprint’s overarching argument for the reason stated above. But the court disagrees with Sprint’s proposed structure. Instead, the evidence indicates that the structure that performs the claimed function is, alternatively, fiber interface 454 within expansion interface 263, or DS1 trunk interface 442.

The court recognizes that this result—like first means—is not anticipated by either party. And the impact of this construction is equally unclear. Therefore, the court may reconsider this construction if either party can address the court’s concerns (*see supra* IV(B)(1)). But, based on the law and evidence currently before it, the court sustains in part Sprint’s objection and construes the second means in all four claims as:

rolling claim construction, in which the court revisits and alters its interpretation of the claim terms as its understanding of the technology evolves.”).

Function: Transmitting packets carrying the outgoing traffic of the individual calls in statistically-multiplexed form on the at least one link connected to the cell, and receiving packets carrying incoming voice call traffic of the individual calls in statistically-multiplexed form on the at least one link connected to the cell for transmission of the incoming traffic to destinations of the incoming traffic

Structure: Fiber interface 454 within expansion interface 263, and DS1 trunk interface 442

C. Claim 8 ('090 Patent)

Claim 8 includes two more MPF terms that require construction.

1. Means for Controlling [Incoming]

The relevant language is:

means for controlling time instants of switching system transmission from the switching system of the incoming traffic to ensure that the packets carrying the incoming traffic will have been received at the switching system within predetermined windows of time prior to the time instants of their transmission from the switching system[.]

'090 Patent at claim 8. Sprint objects to the recommended function and structure.

a) Function

Sprint objects that the word “ensure” means “guarantee.” For the reasons listed above (*see supra* IV(A)(2)), the court overrules Sprint’s objection. Sprint next objects that “their” refers to “packets carrying the incoming traffic.” The court agrees with Sprint. The court recognizes that this construction excludes every disclosed embodiment. The court strives to interpret claims to avoid this result. But this is a situation where there is only one reasonable interpretation of the claim language. Specifically, “their” is a plural pronoun. And the only plural noun (or antecedent) in the claim that “their” could be referring to is “packets carrying the incoming traffic.”

The court does not lightly reach this construction. But case law requires this result. For example, in *Chef America, Inc. v. Lamb-Weston, Inc.*, 358 F.3d 1371 (Fed. Cir. 2007), the court adopted a construction that excluded every disclosed embodiment. The court reached that conclusion

even though the specification indicated that the oven—not the dough—was to be heated to 400 to 850 degrees Fahrenheit. *Id.* at 1373–74. Here, the situation is the same. The court recognizes that the specification teaches that packets are received by the switching system and that segments are transmitted from the switching system. But the claim language never mentions “segments.” Rather, it only mentions packets.

High Point does not argue that “their” was a drafting mistake even though “their” was added by amendment one day after an examiner interview. *See Novo Indus., L.P. v. Micro Molds Corp.*, 350 F.3d 1348, 1354 (Fed. Cir. 2003) (outlining the standard for a district court to apply to “correct an error in a patent by interpretation of the patent where no certificate of correction has been issued”). That is its prerogative. Rather, High Point argues that a POSITA would understand that “their” had to be referring to call traffic segments. That might be true.¹¹ But that is not enough for the court to alter the claim language in this case particularly when High Point’s position requires the court to conclude that “their” is referring to a plural noun that does not expressly appear in the claim. *See, e.g., Allen Eng’g Corp. v. Bartell Indus., Inc.*, 299 F.3d 1336, 1349 (Fed. Cir. 2002) (determining that Allen “stretches the law too far” when it argues that “one of skill in the art would understand that the term ‘perpendicular’ in the claim should be read to mean ‘parallel’”).

For these reasons, the court agrees with Sprint that “their” is referring to “packets carrying the incoming traffic.” It is undisputed that this result excludes all disclosed embodiments. As such, this claim element lacks corresponding structure. Accordingly, the court sustains Sprint’s objection in part and construes this term as:

Function: Controlling time instants of switching system transmission from the switching system of the incoming traffic to ensure that the packets carrying the incoming traffic will have been received at the switching system within

¹¹ The court notes that Sprint’s expert does not reach this conclusion. *See* 8-18-2011 at 905:9–15 (testifying that “their” referred to packets). And High Point’s expert did not originally reach this conclusion. *See id.* at 900:22–901:3 (testifying in his deposition that “their” referred to time instants).

predetermined windows of time prior to the time instants of the transmission of the packets from the switching system

Structure: **Not disclosed**

2. Means for Controlling [Outgoing]

The relevant language is:

means for controlling time instants of switching system transmission from the switching system of the packets carrying the outgoing traffic to ensure receipt of the transmitted packets, at a cell serving a user terminal for which the transmitted packets are destined, within predetermined windows of time[.]

'090 Patent at claim 8. Sprint objects to the claimed function and structure. For the reasons stated above (*see supra* IV(A)(2)) the court overrules Sprint's objection with respect to "ensure." The court also overrules Sprint's objection to the corresponding structure. Processor 602 accomplishes the claimed function, and the recommended algorithm is the corresponding structure. Accordingly, the court overrules Sprint's objections and construes this term as:

Function: **Controlling time instants of switching system transmission from the switching system of the packets carrying the outgoing traffic to ensure receipt of the transmitted packets, at a cell serving a user terminal for which the transmitted packets are destined, within predetermined windows of time**

Structure: **Processor 602, programmed to respond to timing information contained in packets received from a cell by adjusting the timing of transmission from the switching system of future outgoing packets to bring receipt of those packets at the cell within predetermined time windows**

D. '308 Patent

The court reviewed each party's objections to the recommended function and structure of these claim terms. For substantially the same reasons as those identified in the R&R, the court overrules all of Sprint's objections to these terms. With respect to the first means, the court determines that additional structure is not required for claims 13 and 17 to account for the "at regular interval" language. The claimed functions are "transmitting" and "receiving" packets. The evidence at the

Markman hearing indicates that these functions are performed by LAN bus interface 601. With respect to the third means, the court determines that a vocoder is a known structure that is capable of performing the claimed function. For example, the patent expressly states that vocoders “are well known in the art.” ‘090 Patent at 18:5-6. It is not a general purpose computer and, therefore, an algorithm is not required. Finally, with respect to fourth means, the court determines that “assigning” is not a claimed function.

High Point asks this court to clarify the recommended structure for the first means. As noted above, the corresponding structure is LAN bus interface 601. Accordingly, the court sustains High Point’s objection on this issue. The court makes the following constructions:

First Means

Function (claim 13): Receiving at regular intervals from a packet transmission medium first packets each carrying a block of coded voice traffic for an individual call incoming from a radio telephone and transmitting at regular intervals on the packet transmission medium second packets each carrying a block of coded voice traffic for the individual call outgoing to a radio telephone

Function (claim 17): Receiving from a packet transmission medium first packets for a plurality of calls, the first packets for each individual call being received at regular intervals and each carrying a block of coded voice traffic incoming from a radio telephone for the individual call, and transmitting on the packet transmission medium second packets for the plurality of calls, the second packets for each individual call being transmitted at regular intervals and each carrying a block of coded voice traffic outgoing to the radio telephone for the individual call

Function (claim 28): Receiving from a packet transmission medium first packets each carrying a block of coded voice traffic for a call incoming from a radio telephone and transmitting on the packet transmission medium second packets each carrying a block of coded voice traffic for the call outgoing to a radio telephone

Structure (all): LAN bus interface 601

Third Means

Function (claim 13, 28): Decoding the blocks of coded incoming call traffic output by the second means to generate an output stream of incoming call traffic, and coding a received input stream of outgoing call traffic into blocks of coded outgoing call traffic for receipt by the second means

Function (claim 17): Decoding the blocks of coded incoming call traffic output by the second means for a different individual one of the calls to generate an output stream of incoming call traffic for the individual one call, and coding a received input stream of outgoing call traffic for the individual one call to generate blocks of coded outgoing call traffic for the individual one call for receipt by the second means

Structure (all): Vocoder 604

Fourth Means

Function (claim 13, 28): Transmitting the output stream of incoming call traffic generated by the third means in first time slots that are assigned to the individual call on a time-division-multiplexed medium, and receiving the input stream of outgoing call traffic in second time slots that are assigned to the individual call on the time-division multiplexed medium and supplying the received stream to the third means

Function (claim 17): Transmitting the output streams of incoming traffic for the individual calls generated by the plurality of third means in first time slots of a time-division-multiplexed medium, the output stream of incoming traffic for each individual one of the calls being transmitted in ones of the first time slots which are assigned to the individual one of the calls, and receiving input streams of outgoing call traffic for the individual calls in second time slots of the time-division-multiplexed medium, the input stream of outgoing traffic for each individual one of the call being received in ones of the second time slots which are assigned to the individual one of the calls, and supplying the received streams to the plurality of the third means

Structure (all): TDM bus interface 608

IT IS THEREFORE ORDERED that plaintiff's Motion to Adopt in Part, and Clarify and Modify In Part, the Special Master's Report and Recommendation on Claim Construction (Doc. 742) is granted in part.

IT IS FURTHER ORDERED that Sprint's Motion for Review of Special Master Bayer's Report and Recommendation on Claim Construction (Doc. 744) is granted in part.

IT IS FURTHER ORDERED that the Special Master's Report and Recommendation on Claim Construction (Doc. 722) is adopted in part.

Dated this 3rd day of August, 2012, at Kansas City, Kansas.

s/ Carlos Murguia
CARLOS MURGUIA
United States District Judge