

**UNITED STATES DISTRICT COURT  
WESTERN DISTRICT OF LOUISIANA  
LAFAYETTE DIVISION**

**TOTAL REBUILD, INC.**

**CASE NO. 6:15-CV-1855**

**VERSUS**

**JUDGE TERRY A. DOUGHTY**

**PHC FLUID POWER, L.L.C.**

**MAG. JUDGE CAROL B.  
WHITEHURST**

**MEMORANDUM OPINION AND ORDER ON CLAIM CONSTRUCTION**

On April 4, 2019, the parties stipulated to submitting the pending claim construction for United States Patent No. 8,146,428 (“the ’428 Patent”) on the briefs. [Doc. No. 265]. Having considered the arguments made by the parties in their briefing [Doc. Nos. 73, 78, & 83], having considered the intrinsic evidence, and having made subsidiary factual findings about the extrinsic evidence, the Court hereby issues this Claim Construction Memorandum and Order. *See Phillips v. AWH Corp.*, 415 F.3d 1303, 1314 (Fed. Cir. 2005); *Teva Pharm. USA, Inc. v. Sandoz, Inc.*, 135 S. Ct. 831, 841 (2015).

TABLE OF CONTENTS

I. BACKGROUND ..... 3

II. APPLICABLE LAW ..... 5

III. CONSTRUCTION OF AGREED TERMS ..... 11

IV. CONSTRUCTION OF DISPUTED TERMS ..... 12

    1. “explosion-proof safety housing” ..... 12

    2. “closeable access opening in said housing” ..... 20

    3. “means within said housing for coupling said high-pressure pneumatics testing equipment to said high-pressure device for testing” ..... 24

    4. “means linking said high-pressure pneumatics testing equipment to said control panel” ..... 31

    5. “means for monitoring and recording” ..... 40

    6. “stationary housing” ..... 45

V. CONCLUSION..... 50

## I. BACKGROUND

The '428 Patent was filed on August 7, 2009, issued on April 3, 2012, and is titled Safety System. The '428 Patent generally relates to a safety system for testing high-pressure devices. '428 Patent at Abstract. The specification states that “[t]he testing of high-pressure devices and the various components of the high-pressure devices, by its very nature, is an inherently dangerous activity as one is in search of faults in devices that can potentially lead to disastrous.” *Id.* at 1:28–31. The specification indicates that the main design problem is “the creation of a barrier that will not only stop the fragments in case the high-pressure testing equipment happens to fail but will also include safety features to help minimize the exposure of operator(s) to the high-pressure testing equipment during the testing stage.” *Id.* at 1:56–60.

In one embodiment, safety system 10 includes “a stationary explosion-proof safety housing comprising a bunker housing 11 having a chamber 12 therein.” *Id.* at 2:49–51. Figure 1 is a schematic view of this embodiment.

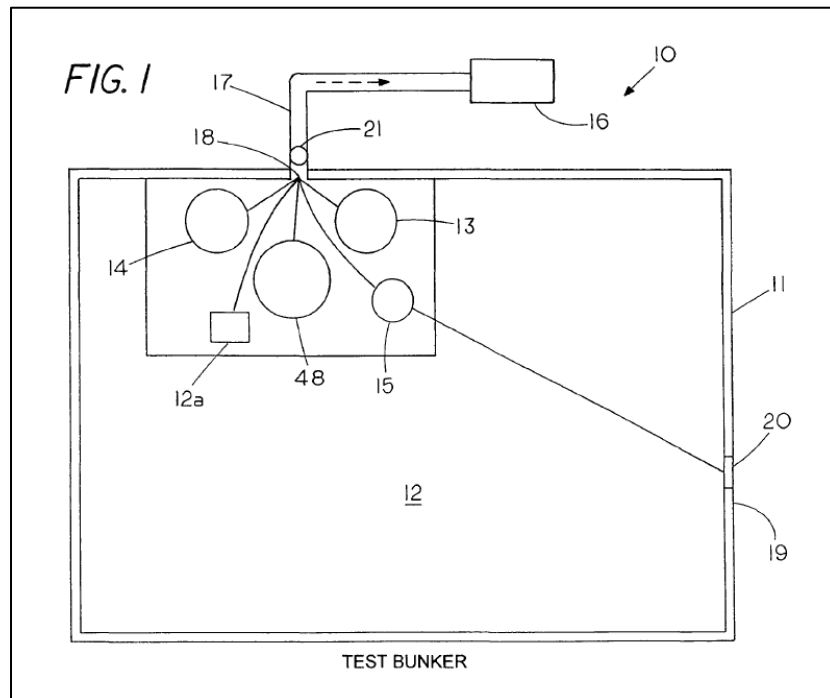

*Id.* at Figure 1. The specification states that “bunker housing 11 may be formed from a plurality of materials that is able to withstand the impact of high velocity projectile/high-speed flying fragments resulting from explosion of pressure equipments including valves, piping, fittings, ruptured disks, intensifiers and pumps, as well as pressure vessels.” *Id.* at 2:51–56. The specification further states that “high-pressure pneumatics testing equipment [13, 14, 15] and means 12a for coupling the high-pressure pneumatics testing equipment to a high-pressure device for testing” are located entirely within chamber 12. *Id.* at 3:1–3. Similarly, the specification indicates that “a majority if not all associated pumps, plumbing, hoses, and bleed valves are to also be located entirely within chamber 12.” *Id.* at 3:35–38.

The specification further discloses that “[s]afety system 10 also includes a control panel 16 located outside of the chamber 12 of bunker housing 11 and means linking the high-pressure pneumatics testing equipment to the control panel 16 for operating the high-pressure pneumatics testing equipment within bunker housing 11 from control panel 16.” *Id.* at 3:26–31. The specification indicates that this keeps “all pressure in the bunker housing 11 away from the operator.” *Id.* at 3:16.

Claim 1 of the ’428 Patent recites the following elements (disputed term in italics):

1. A safety system for testing high-pressure devices comprising:
  - an *explosion-proof safety housing*;
  - a high-pressure pneumatics testing equipment located within said housing;
  - a bleed valve coupled to said high-pressure pneumatics testing equipment;
  - a *closeable access opening in said housing* for inserting a high-pressure device for testing within said housing;
  - means within said housing for coupling said high-pressure pneumatics testing equipment to said high-pressure device for testing*;
  - a control panel located remote from said housing; and
  - means linking said high-pressure pneumatics testing equipment to said control panel* for operating said high-pressure

pneumatics testing equipment within said safety housing from said control panel.

## II. APPLICABLE LAW

### A. Claim Construction

“It is a ‘bedrock principle’ of patent law that ‘the claims of a patent define the invention to which the patentee is entitled the right to exclude.’” *Phillips v. AWH Corp.*, 415 F.3d 1303, 1312 (Fed. Cir. 2005) (en banc) (quoting *Innova/Pure Water Inc. v. Safari Water Filtration Sys., Inc.*, 381 F.3d 1111, 1115 (Fed. Cir. 2004)). To determine the meaning of the claims, courts start by considering the intrinsic evidence. *Id.* at 1313; *C.R. Bard, Inc. v. U.S. Surgical Corp.*, 388 F.3d 858, 861 (Fed. Cir. 2004); *Bell Atl. Network Servs., Inc. v. Covad Commc’ns Group, Inc.*, 262 F.3d 1258, 1267 (Fed. Cir. 2001). The intrinsic evidence includes the claims themselves, the specification, and the prosecution history. *Phillips*, 415 F.3d at 1314; *C.R. Bard, Inc.*, 388 F.3d at 861. The general rule—subject to certain specific exceptions discussed *infra*—is that each claim term is construed according to its ordinary and accustomed meaning as understood by one of ordinary skill in the art at the time of the invention in the context of the patent. *Phillips*, 415 F.3d at 1312–13; *Alloc, Inc. v. Int’l Trade Comm’n*, 342 F.3d 1361, 1368 (Fed. Cir. 2003); *Azure Networks, LLC v. CSR PLC*, 771 F.3d 1336, 1347 (Fed. Cir. 2014) (“There is a heavy presumption that claim terms carry their accustomed meaning in the relevant community at the relevant time.”) (vacated on other grounds).

“The claim construction inquiry . . . begins and ends in all cases with the actual words of the claim.” *Renishaw PLC v. Marposs Societa’ per Azioni*, 158 F.3d 1243, 1248 (Fed. Cir. 1998). “[I]n all aspects of claim construction, ‘the name of the game is the claim.’” *Apple Inc. v. Motorola, Inc.*, 757 F.3d 1286, 1298 (Fed. Cir. 2014) (quoting *In re Hiniker Co.*, 150 F.3d 1362, 1369 (Fed. Cir. 1998)). First, a term’s context in the asserted claim can be instructive. *Phillips*, 415 F.3d at

1314. Other asserted or unasserted claims can also aid in determining the claim’s meaning, because claim terms are typically used consistently throughout the patent. *Id.* Differences among the claim terms can also assist in understanding a term’s meaning. *Id.* For example, when a dependent claim adds a limitation to an independent claim, it is presumed that the independent claim does not include the limitation. *Id.* at 1314–15.

“[C]laims ‘must be read in view of the specification, of which they are a part.’” *Id.* (quoting *Markman v. Westview Instruments, Inc.*, 52 F.3d 967, 979 (Fed. Cir. 1995) (en banc)). “[T]he specification ‘is always highly relevant to the claim construction analysis. Usually, it is dispositive; it is the single best guide to the meaning of a disputed term.’” *Id.* (quoting *Vitronics Corp. v. Conceptronic, Inc.*, 90 F.3d 1576, 1582 (Fed. Cir. 1996)); *Teleflex, Inc. v. Ficosa N. Am. Corp.*, 299 F.3d 1313, 1325 (Fed. Cir. 2002). But, “[a]lthough the specification may aid the court in interpreting the meaning of disputed claim language, particular embodiments and examples appearing in the specification will not generally be read into the claims.” *Comark Commc’ns, Inc. v. Harris Corp.*, 156 F.3d 1182, 1187 (Fed. Cir. 1998) (quoting *Constant v. Advanced Micro-Devices, Inc.*, 848 F.2d 1560, 1571 (Fed. Cir. 1988)); *see also Phillips*, 415 F.3d at 1323. “[I]t is improper to read limitations from a preferred embodiment described in the specification—even if it is the only embodiment—into the claims absent a clear indication in the intrinsic record that the patentee intended the claims to be so limited.” *Liebel-Flarsheim Co. v. Medrad, Inc.*, 358 F.3d 898, 913 (Fed. Cir. 2004).

The prosecution history is another tool to supply the proper context for claim construction because, like the specification, the prosecution history provides evidence of how the U.S. Patent and Trademark Office (“PTO”) and the inventor understood the patent. *Phillips*, 415 F.3d at 1317. However, “because the prosecution history represents an ongoing negotiation between the PTO

and the applicant, rather than the final product of that negotiation, it often lacks the clarity of the specification and thus is less useful for claim construction purposes.” *Id.* at 1318; *see also Athletic Alternatives, Inc. v. Prince Mfg.*, 73 F.3d 1573, 1580 (Fed. Cir. 1996) (ambiguous prosecution history may be “unhelpful as an interpretive resource”).

Although extrinsic evidence can also be useful, it is “less significant than the intrinsic record in determining the legally operative meaning of claim language.” *Phillips*, 415 F.3d at 1317 (quoting *C.R. Bard, Inc.*, 388 F.3d at 862). Technical dictionaries and treatises may help a court understand the underlying technology and the manner in which one skilled in the art might use claim terms, but technical dictionaries and treatises may provide definitions that are too broad or may not be indicative of how the term is used in the patent. *Id.* at 1318. Similarly, expert testimony may aid a court in understanding the underlying technology and determining the particular meaning of a term in the pertinent field, but an expert’s conclusory, unsupported assertions as to a term’s definition are entirely unhelpful to a court. *Id.* Generally, extrinsic evidence is “less reliable than the patent and its prosecution history in determining how to read claim terms.” *Id.* The Supreme Court recently explained the role of extrinsic evidence in claim construction:

In some cases, however, the district court will need to look beyond the patent’s intrinsic evidence and to consult extrinsic evidence in order to understand, for example, the background science or the meaning of a term in the relevant art during the relevant time period. *See, e.g., Seymour v. Osborne*, 11 Wall. 516, 546 (1871) (a patent may be “so interspersed with technical terms and terms of art that the testimony of scientific witnesses is indispensable to a correct understanding of its meaning”). In cases where those subsidiary facts are in dispute, courts will need to make subsidiary factual findings about that extrinsic evidence. These are the “evidentiary underpinnings” of claim construction that we discussed in *Markman*, and this subsidiary factfinding must be reviewed for clear error on appeal.

*Teva Pharm. USA, Inc. v. Sandoz, Inc.*, 135 S. Ct. 831, 841 (2015).

## B. Departing from the Ordinary Meaning of a Claim Term

There are “only two exceptions to [the] general rule” that claim terms are construed according to their plain and ordinary meaning: “1) when a patentee sets out a definition and acts as his own lexicographer, or 2) when the patentee disavows the full scope of the claim term either in the specification or during prosecution.”<sup>1</sup> *Golden Bridge Tech., Inc. v. Apple Inc.*, 758 F.3d 1362, 1365 (Fed. Cir. 2014) (quoting *Thorner v. Sony Computer Entm’t Am. LLC*, 669 F.3d 1362, 1365 (Fed. Cir. 2012)); *see also GE Lighting Solutions, LLC v. AgiLight, Inc.*, 750 F.3d 1304, 1309 (Fed. Cir. 2014) (“[T]he specification and prosecution history only compel departure from the plain meaning in two instances: lexicography and disavowal.”). The standards for finding lexicography or disavowal are “exacting.” *GE Lighting Solutions*, 750 F.3d at 1309.

To act as his own lexicographer, the patentee must “clearly set forth a definition of the disputed claim term,” and “clearly express an intent to define the term.” *Id.* (quoting *Thorner*, 669 F.3d at 1365); *see also Renishaw*, 158 F.3d at 1249. The patentee’s lexicography must appear “with reasonable clarity, deliberateness, and precision.” *Renishaw*, 158 F.3d at 1249.

To disavow or disclaim the full scope of a claim term, the patentee’s statements in the specification or prosecution history must amount to a “clear and unmistakable” surrender. *Cordis Corp. v. Boston Sci. Corp.*, 561 F.3d 1319, 1329 (Fed. Cir. 2009); *see also Thorner*, 669 F.3d at 1366 (“The patentee may demonstrate intent to deviate from the ordinary and accustomed meaning of a claim term by including in the specification expressions of manifest exclusion or restriction, representing a clear disavowal of claim scope.”). “Where an applicant’s statements are amenable to multiple reasonable interpretations, they cannot be deemed clear and unmistakable.” *3M*

---

<sup>1</sup> Some cases have characterized other principles of claim construction as “exceptions” to the general rule, such as the statutory requirement that a means-plus-function term is construed to cover the corresponding structure disclosed in the specification. *See, e.g., CCS Fitness, Inc. v. Brunswick Corp.*, 288 F.3d 1359, 1367 (Fed. Cir. 2002).



*Innovative Proprs. Co. v. Tredegar Corp.*, 725 F.3d 1315, 1326 (Fed. Cir. 2013); *see also Avid Tech., Inc. v. Harmonic, Inc.*, 812 F.3d 1040, 1045 (Fed. Cir. 2016) (“When the prosecution history is used solely to support a conclusion of patentee disclaimer, the standard for justifying the conclusion is a high one.”).

Although a statement of lexicography or disavowal must be exacting and clear, it need not be “explicit.” *See Trs. of Columbia Univ. v. Symantec Corp.*, 811 F.3d 1359, 1364 (Fed. Cir. 2016) (“a patent applicant need not expressly state ‘my invention does not include X’ to indicate his exclusion of X from the scope of his patent”). Lexicography or disavowal can be implied where, *e.g.*, the patentee makes clear statements characterizing the scope and purpose of the invention. *See On Demand Mach. Corp. v. Ingram Indus., Inc.*, 442 F.3d 1331, 1340 (Fed. Cir. 2006) (“[W]hen the scope of the invention is clearly stated in the specification, and is described as the advantage and distinction of the invention, it is not necessary to disavow explicitly a different scope.”). Nonetheless, the plain meaning governs “[a]bsent implied or explicit lexicography or disavowal.” *Trs. of Columbia Univ.*, 811 F.3d at 1364 n.2.

### C. 35 U.S.C. § 112(6) (pre-AIA) / § 112(f) (AIA)<sup>2</sup>

A patent claim may be expressed using functional language. *See* 35 U.S.C. § 112, ¶ 6; *Williamson v. Citrix Online, LLC*, 792 F.3d 1339, 1347–49 & n.3 (Fed. Cir. 2015) (en banc in relevant portion). Section 112, Paragraph 6, provides that a structure may be claimed as a “means . . . for performing a specified function” and that an act may be claimed as a “step for performing a specified function.” *Masco Corp. v. United States*, 303 F.3d 1316, 1326 (Fed. Cir. 2002).

---

<sup>2</sup> Because the application resulting in the ’428 Patent was filed before September 16, 2012, the effective date of the America Invents Act (“AIA”), the Court refers to the pre-AIA version of § 112.

But § 112, ¶ 6 does not apply to all functional claim language. There is a rebuttable presumption that § 112, ¶ 6 applies when the claim language includes “means” or “step for” terms, and that it does not apply in the absence of those terms. *Masco Corp.*, 303 F.3d at 1326; *Williamson*, 792 F.3d at 1348. The presumption stands or falls according to whether one of ordinary skill in the art would understand the claim with the functional language, in the context of the entire specification, to denote sufficiently definite structure or acts for performing the function. *See Media Rights Techs., Inc. v. Capital One Fin. Corp.*, 800 F.3d 1366, 1372 (Fed. Cir. 2015) (§ 112, ¶ 6 does not apply when “the claim language, read in light of the specification, recites sufficiently definite structure” (quotation marks omitted) (citing *Williamson*, 792 F.3d at 1349; *Robert Bosch, LLC v. Snap-On Inc.*, 769 F.3d 1094, 1099 (Fed. Cir. 2014))); *Williamson*, 792 F.3d at 1349 (§ 112, ¶ 6 does not apply when “the words of the claim are understood by persons of ordinary skill in the art to have sufficiently definite meaning as the name for structure”); *Masco Corp.*, 303 F.3d at 1326 (§ 112, ¶ 6 does not apply when the claim includes an “act” corresponding to “how the function is performed”); *Personalized Media Communications, L.L.C. v. International Trade Commission*, 161 F.3d 696, 704 (Fed. Cir. 1998) (§ 112, ¶ 6 does not apply when the claim includes “sufficient structure, material, or acts within the claim itself to perform entirely the recited function . . . even if the claim uses the term ‘means.’”) (quotation marks and citation omitted).

When it applies, § 112, ¶ 6 limits the scope of the functional term “to only the structure, materials, or acts described in the specification as corresponding to the claimed function and equivalents thereof.” *Williamson*, 792 F.3d at 1347. Construing a means-plus-function limitation involves multiple steps. “The first step . . . is a determination of the function of the means-plus-function limitation.” *Medtronic, Inc. v. Advanced Cardiovascular Sys., Inc.*, 248 F.3d 1303, 1311 (Fed. Cir. 2001). “[T]he next step is to determine the corresponding structure disclosed in the

specification and equivalents thereof.” *Id.* A “structure disclosed in the specification is ‘corresponding’ structure only if the specification or prosecution history clearly links or associates that structure to the function recited in the claim.” *Id.* The focus of the “corresponding structure” inquiry is not merely whether a structure is capable of performing the recited function, but rather whether the corresponding structure is “clearly linked or associated with the [recited] function.” *Id.* The corresponding structure “must include all structure that actually performs the recited function.” *Default Proof Credit Card Sys. v. Home Depot U.S.A., Inc.*, 412 F.3d 1291, 1298 (Fed. Cir. 2005). However, § 112, ¶ 6 does not permit “incorporation of structure from the written description beyond that necessary to perform the claimed function.” *Micro Chem., Inc. v. Great Plains Chem. Co.*, 194 F.3d 1250, 1258 (Fed. Cir. 1999).

### III. CONSTRUCTION OF AGREED TERMS

The parties agreed to the constructions of the following terms/phrases:

<b>Claim Term/Phrase</b>	<b>Agreed Construction</b>
“control panel located remote from said housing”	“a device, positioned outside of or exterior to the housing for operating the high-pressure testing equipment”
“said sensor coupled to said bleed valve”	“a sensor in communication with the bleed valve for actuation of the bleed valve”
“activate said bleed valve to prevent pressure buildup”	“actuation of the bleed valve to prevent pressure buildup in the high-pressure testing equipment when door is open”
“portable housing”	“a housing that is movable or transportable to different testing sites”
“bleed valve coupled to said high-pressure pneumatics testing equipment”	“a valve joined or linked to testing equipment to prevent pressure buildup in testing equipment when the closable access opening is not closed”
“sensor for sensing that said access opening is closed”	“a switch capable of sensing input regarding whether the door is open or closed”

[Doc. No. 59 at 1-2].<sup>3</sup> In view of the parties’ agreement on the proper construction of the identified terms, the Court hereby **ADOPTS** the parties’ agreed constructions.

**IV. CONSTRUCTION OF DISPUTED TERMS**

The parties dispute the meaning and scope of six terms/phrases of the ’428 Patent.

**1. “explosion-proof safety housing”**

<u>Disputed Term</u>	<u>Plaintiff’s Proposal</u>	<u>Defendant’s Proposal</u>
“explosion-proof safety housing”	“a case or enclosure to cover and protect a structure or a mechanical device able to withstand and confine shock pressure, pressure blasts, flying fragments or debris, and energy resulting from combustion”	“stationary bunker or portable housing with an enclosed space or cavity”

**a) The Parties’ Positions**

The parties dispute whether the term “explosion-proof safety housing” should be construed as a “stationary bunker or portable housing with an enclosed space or cavity,” as Defendant proposes. Plaintiff argues that the term “housing” is well understood as “[a] case or enclosure to cover and protect a structure or a mechanical device.” [Doc. No. 73 at 16] (citing Dictionary of Engineering, McGraw-Hill, 2nd ed. 2002). Plaintiff further argues that the term “housing” does not require considerable explanation and must be given its ordinary meaning. *Id.* at 17. Plaintiff contends that Figure 1 “shows the housing as a case or enclosure to contain within the housing not only the device to be tested but as well the pneumatic testing equipment and associated pumps, plumbing, hoses, and valves.” *Id.* (citing ’428 Patent at 3:36–38).

Regarding Defendant’s construction, Plaintiff argues that it violates the doctrine of claim differentiation. *Id.* Plaintiff contends that interpreting the term “housing” to mean a “stationary

---

<sup>3</sup> Citations to the parties’ filings are to the filing’s number in the docket [Doc. No.] and pin cites are to the page numbers assigned through ECF.

bunker” or “portable housing,” would render claims 7, 8, and 14 superfluous and redundant to claims 1 and 11, respectively. *Id.* at 18. Plaintiff further argues that the phrase “explosion-proof” indicates that the housing must be capable of not only functioning as a case or enclosure for containing the device to be tested, but also to withstand and contain such shock pressures, pressure blasts, flying fragments or debris, and the energy resulting from combustion. *Id.* at 18-19. Plaintiff contends that Defendant’s construction completely ignores that the housing is “explosion-proof,” and does not accurately reflect the use of the term in the art or in the context of the patent. *Id.* at 19. According to Plaintiff, the term “explosion-proof safety housing” must be construed to be “a case or enclosure to cover and protect a structure or a mechanical device able to withstand and confine shock pressure, pressure blasts, flying fragments or debris, and energy resulting from combustion.” *Id.*

Defendant responds that the specification defines an “explosion-proof safety housing” as “comprising a bunker housing 11 having a chamber 12 therein.” [Doc. No. 78 at 16] (citing ’428 Patent at 2:49–51). According to Defendant, the definition of “explosion-proof safety housing” that includes “bunker” must be taken into account. *Id.* at 16-17. Defendant further contends that Plaintiff argues that the safety-housing must have a roof or top portion to cover the devices being tested in the housing. *Id.* at 17. Defendant argues that there is no language in the specification or the claims that sets the requirement that the safety housing must have a roof or cover. *Id.* Defendant contends that Plaintiff has presented no evidence that any bunker must have a roof or cover. *Id.*

Defendant also contends that the term “chamber” is defined as “a natural or artificial enclosed space or cavity.” *Id.* (citing Merriam-Webster.com, <http://www.merriam-webster.com/dictionary/chamber>). Defendant argues that the chamber (12) is displayed in Figure

1 as a volume within the housing. *Id.* Defendant also argues that the chamber (44) in Figure 5 is also displayed as a volume within the housing. *Id.* at 18 (citing '428 Patent at 5:44-47). According to Defendant, the '428 Patent clearly describes both a stationary bunker and a portable housing, each with an enclosed space or cavity. *Id.*

Regarding Plaintiff's construction, Defendant argues that Plaintiff's construction ignores these limitations in the specification and instead turns to extrinsic evidence to support its construction of "explosion-proof safety housing." *Id.* Defendant also argues that Plaintiff's interpretation is also erroneous because it misapplies the doctrine of claim differentiation. *Id.* at 19. Defendant contends that the dependent claims, claims 7, 8, and 14, recite either "stationary housing" or "portable housing" but not both terms. *Id.* Defendant argues that under its construction the dependent claims will be narrower, and thus necessarily not superfluous to the independent claims. *Id.*

Plaintiff replies that Defendant's disregard of the term "explosion proof" dilutes the meaning of the term and defines it so that it may apply to inapplicable prior art. [Doc. No. 83 at 10]. Plaintiff argues that the correct construction of "explosion proof safety housing" must be construed to include the meaning of the limitation "explosion proof." *Id.* Plaintiff also argues that Defendant's construction attempts to read the limitations of dependent claims 7, 8, and 14 into independent claims 1 and 11. *Id.* Plaintiff contends that Defendant's construction would be redundant because the limitations of "a stationary bunker or portable housing" would already have been stated in the construction of independent claims 1 and 11. *Id.* Finally, Plaintiff states that it has no objection to including "bunker" and "chamber" in its proposed construction. *Id.*

#### **b) Analysis**

The phrase "explosion-proof safety housing" appears in claims 1, 7, 8, 11, 14, and 16 of

the '428 Patent. The Court finds that the phrase is used consistently in the claims and is intended to have the same general meaning in each claim. The Court further finds that the term “housing” does not require construction, because the term is unambiguous, and is easily understandable by a jury, and should be given its plain and ordinary meaning. Indeed, Defendant includes the term “housing” in its proposed construction. That said, the specification also identifies the “explosion-proof safety housing” as a bunker or an enclosure. Specifically, the specification states that Figure 1 “shows a schematic view of an embodiment of a safety system 10 of the present invention for safely pressure testing high-pressure devices and components of high-pressure equipments.” '428 Patent at 2:40–43. The specification adds that “[s]afety system 10 includes a stationary explosion-proof safety housing comprising *a bunker housing 11 having a chamber 12 therein.*” *Id.* at 2:49–51 (emphasis added). The following figure shows the housing (11) outlined in red.

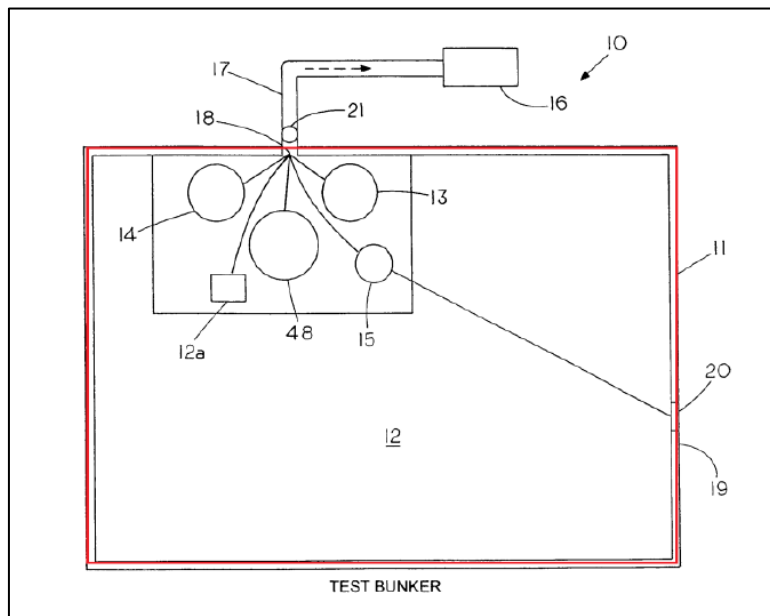

*Id.* at Figure 1 (annotated). The specification states that the high pressure testing equipment (*i.e.*, low-pressure pump 13, intermediate-pressure pump 14, high-pressure pump 48, and bleed valve 15) are enclosed in housing 11. *Id.* at 3:13–16. Similarly, in describing an alternate embodiment, the specification states that “unlike the bunker housing 11 of safety system 10, which comprises a

stationary *enclosure*, the testing housing 45 of portable safety system 40 comprises a smaller portable *enclosure or housing* that may be moved to different testing sites.” *Id.* at 5:43–47. Accordingly, the specification identifies the recited “housing” as an “enclosure” or a “bunker.”

Regarding the term “explosion-proof safety,” the Court finds that the term should be construed to mean “able to withstand and confine shock pressure, pressure blasts, flying fragments or debris, and energy resulting from combustion or release of elastic energy stored in a compressible fluid.” In describing bunker housing 11, the specification states the following:

In regards to bunker housing 11, bunker housing 11 may be form from a plurality of materials that is *able to withstand the impact of high velocity projectile/high-speed flying fragments* resulting from explosion of pressure equipments including valves, piping, fittings, ruptured disks, intensifiers and pumps, as well as pressure vessels. The materials of bunker housing 11 may also *be able to withstand and confine shock wave or shock pressure* radiated by explosions resulting from the use of a gas as the pressure medium in high-pressure testing or is fluids is used as the pressure medium in high-pressure testing, the flashing or geysering of a compressed fluid to a vapor state resulting from the compressed fluid rapidly passing through an orifice wherein elastic energy is then converted to heat. Suitable materials for the manufacture of bunker housing 11 include but are not limited to concrete and various metals such as steel, aluminum and their alloys.

*Id.* at 2:51–67 (emphasis added). Similarly, the Background section of the specification states that “[e]xamples of two types of hazards that are associated with the testing of high-pressure devices include *shock from a pressure blast and flying fragments and debris* . . . . The energy released to create such overpressures may *result from combustion, or may be due to the release of elastic energy stored in a compressible fluid.*” *Id.* at 1:36–45 (emphasis added). The specification adds that the main “design problems associated with *the hazards of shock from a pressure blast and flying fragment and debris* is the creation of high-pressure testing equipments that will operate safely under the desired pressure and the creation of a barrier that will not only stop the fragments in case the high-pressure testing equipment happens to fail but will also include safety features to help minimize the exposure of operator(s) to the high-pressure testing equipment during the testing



stage.” *Id.* at 1:52–59.

Thus, the use of the phrase “explosion-proof safety” in the context of the intrinsic evidence means that the housing must be capable of not only functioning as a housing or enclosure for the testing equipment, but must also withstand and confine shock pressures, pressure blasts, flying fragments or debris, and the energy resulting from combustion or release of elastic energy stored in a compressible fluid. This limitation provides that the high pressure device is tested in a safe manner by keeping all pressure in the housing away from the operator. *See e.g.*, ’428 Patent at 3:13–16 (“The high-pressure equipment testing equipments may be fluid driven and are controlled by pneumatic switches located outside of bunker housing 11 for safety purposes so as to keep all pressure in the bunker housing 11 away from the operator.”). Accordingly, the intrinsic evidence indicates that the term “explosion-proof safety” means “able to withstand and confine shock pressure, pressure blasts, flying fragments or debris, and energy resulting from combustion or release of elastic energy stored in a compressible fluid.”

Turning to the parties’ construction, Plaintiff’s construction is similar to the Court’s construction, except it incorporates an extrinsic definition for the term “housing.” Plaintiff argues that the Dictionary of Engineering defines “housing” as “[a] case or enclosure to cover and protect a structure or a mechanical device.” [Doc. No. 73 at 16] (Dictionary of Engineering, McGraw-Hill, 2nd ed. 2002). Plaintiff also argues that the term “housing” does not “require considerable explanation to be understood and must be given its ordinary meaning.” *Id.* at 17. The Court agrees that the term “housing” does not require construction, and that the intrinsic evidence further clarifies that “housing” may include a bunker or enclosure.<sup>4</sup> Accordingly, the Court finds

---

<sup>4</sup> In its Reply Brief, Plaintiff states that it does not oppose including the term “bunker” in the construction. [Doc. No. 83 at 11].

Plaintiff's extrinsic definition for housing unnecessary. The Court generally adopts the remaining portion of Plaintiff's construction with the exception of adding "or release of elastic energy stored in a compressible fluid." As indicated above, the specification states that "the energy released to create such overpressures may *result from combustion, or may be due to the release of elastic energy stored in a compressible fluid.*" '428 Patent at 1:43–45 (emphasis added).

Regarding Defendant's construction, the Court rejects it because it is contrary to the doctrine of claim differentiation. The doctrine of claim differentiation is a presumption "that limitations stated in dependent claims are not to be read into the independent claim from which they depend." *Karlin Tech. Inc. v. Surgical Dynamics, Inc.*, 177 F.3d 968, 972 (Fed. Cir. 1999). Claim differentiation is only a presumption and is not "a hard and fast rule of construction" *Seachange Int'l, Inc. v. C-Cor Inc.*, 413 F.3d 1361, 1369 (Fed. Cir. 2005) (quoting *Kraft Foods, Inc. v. Int'l Trading Co.*, 203 F.3d 1362, 1368 (Fed. Cir. 2000)). However, the presumption is at its strongest when a limitation from a dependent claim is sought to be read into an independent claim. *Seachange*, 413 F.3d at 1369 (citing *Liebel-Flarshiem Co. v. Medrad, Inc.*, 358 F.3d 898, 910 (Fed. Cir. 2004)); *see also Ecolab Inc. v. Paraclipse, Inc.*, 285 F.3d 1362, 1375 (Fed. Cir. 2002).

Here, Defendant's construction improperly limits the "housing" to both "stationary" and "portable." The limitation of a "stationary housing" appears in claim 7, a dependent claim of independent claim 1. Similarly, the limitation of "portable housing" appears in claims 8 and 14, dependent claims of independent claims 1 and 11, respectively. Thus, Defendant's construction would incorrectly read the limitations of dependent claims 7, 8, and 14 into independent claims 1 and 11, and would violate the doctrine of claim differentiation. "Claim differentiation, while often argued to be controlling when it does not apply, is clearly applicable when there is a dispute over

whether a limitation found in a dependent claim should be read into an independent claim, and that limitation is the only meaningful difference between the two claims.” *Wenger Mfg., Inc. v. Coating Mach. Sys., Inc.*, 239 F.3d 1225, 1233 (Fed. Cir. 2001). Here, the only meaningful difference in dependent claim 7 is “stationary,” and in dependent claims 8 and 14 is “portable.” Accordingly, the Court rejects Defendant’s construction.

More importantly, Defendant’s construction ignores and completely reads the “explosion-proof safety” limitation out of the claims. The correct construction of the phrase “explosion proof safety housing” must include the meaning of the term “explosion proof.” *Merck & Co. v. Teva Pharm. USA, Inc.*, 395 F.3d 1364, 1372 (Fed. Cir. 2005) (“A claim construction that gives meaning to all the terms of the claim is preferred over one that does not do so.”). As discussed above, the term “explosion-proof safety” means “able to withstand and confine shock pressure, pressure blasts, flying fragments or debris, and energy resulting from combustion or release of elastic energy stored in a compressible fluid.” Defendant’s construction not only fails to interpret the disputed term in light of the intrinsic evidence, it completely eliminates a critical limitation from the scope of the claims. Finally, in reaching its conclusion, the Court has considered the extrinsic evidence submitted by the parties, and given it its proper weight in light of the intrinsic evidence.

#### c) Court’s Construction

The Court construes the term “**explosion-proof safety housing**” to mean “**housing, bunker, or enclosure able to withstand and confine shock pressure, pressure blasts, flying fragments or debris, and energy resulting from combustion or release of elastic energy stored in a compressible fluid.**”

**2. “closeable access opening in said housing”**

<u>Disputed Term</u>	<u>Plaintiff’s Proposal</u>	<u>Defendant’s Proposal</u>
“closeable access opening in said housing”	“a door in the housing which may be opened and closed for inserting a high-pressure device for testing”	“a closeable walk-in door to the stationary bunker for entry by operators, or a small closeable door on the portable test housing”

**a) The Parties’ Positions**

The parties agree that the “opening in said housing” is a door. The parties dispute whether the “door” must be large enough to allow an operator to walk into the housing or bunker, as Defendant proposes. Plaintiff argues that the specification explains that the explosion-proof safety housing (11, 45) includes a closeable access opening (19) comprising a door wherein a high-pressure device for testing may be inserted or placed within housing (11, 45) through the opening 19. [Doc. No. 73 at 20] (citing ’428 Patent at 2:1–3, 3:4–7, 3:55–64, 5:60–6:1, Figure 1).

Regarding Defendant’s construction, Plaintiff argues that it requires “walk-in . . . for entry by operators” for the “stationary housing,” and “small” closeable door for the “portable test housing.” *Id.* Plaintiff further argues that there is no reference in the intrinsic evidence for limiting the closeable access opening so narrowly. *Id.* Plaintiff contends that Defendant’s argument neglects that the use of the word “enter” could allow access or entry of an operator by other means, such as reaching through the access. *Id.* at 21 (citing ’428 Patent at 3:55–57). According to Plaintiff, the use of the word “enter” alone does not rise to the level of manifest exclusion or of restriction as to the size of the door. *Id.* Plaintiff also argues that Defendant has provided no support for the limitation that the closable access be limited to “small”. *Id.* (citing ’428 Patent 5:45–46). Plaintiff contends that without a recitation of the “closable access” being “small,” Defendant’s construction has no support. *Id.* at 21–22.

Defendant responds that the specification discusses the purpose of the closeable access

opening, and states that “[w]hen safety enter switch 20 senses that door 19 is closed, housing door 19 is locked with a device such as an air cylinder so that no user/personnel can enter chamber 12.” [Doc. No. 78 at 20] (citing ’428 Patent at 3:55–57). According to Defendant, the closeable access opening must be one that a user can walk through if the door can be locked “so that no user/personnel can enter chamber 12.” *Id.* Defendant argues that Plaintiff’s construction would render the limitation in the specification meaningless. *Id.* Finally, Defendant contends that there is no closeable access opening numbered in Figure 5 (the portable test housing embodiment), yet the closeable access opening must exist for operation of the device. *Id.*

Plaintiff replies that the “closeable access opening in said housing” is set forth in the specification as door 19 in housing 11 for inserting a high-pressure device for testing. [Doc. No. 83 at 12] (citing ’428 Patent at 2:1–3, 3:4–7, 5:60–6:1, Figure 1). Plaintiff contends that the parties appear to agree that the “closeable access opening” is a door, but Defendant’s construction improperly limits the size of the door. *Id.* Plaintiff argues that Defendant neglects that the “closeable access” would allow access or entry of an operator by any means such as a reaching through the access. *Id.* at 13. Plaintiff further argues that for claims 8 and 14, which introduce the limitation of the “portable housing,” the closeable access would be inherently smaller, but this cannot apply to independent claims 1 and 11 due to the doctrine of claim differentiation. *Id.* Plaintiff restates that without a recitation of the “closeable access” being “small,” Defendant’s construction has no support. *Id.* at 14.

#### **b) Analysis**

The phrase “closeable access opening in said housing” appears in claims 1, 3, 4, 11, 16, and 18 of the ’428 Patent. The Court finds that the phrase is used consistently in the claims and is intended to have the same general meaning in each claim. The Court further finds that the intrinsic

evidence does not limit or require the “opening” to be a certain size, as required by Defendant’s construction. The specification generally discloses two embodiments. In the first embodiment, the specification describes the safety system as “a stationary explosion-proof safety housing comprising a bunker housing 11 having a chamber 12 therein.” ’428 Patent at 2:49–51. The specification discloses that the “[s]afety system 10 also includes a closeable access opening comprising a door 19 in bunker housing 11 for inserting a high-pressure device for testing within bunker housing 11.” *Id.* at 3:4–7, *see also id.* at Abstract (“[A] closeable access opening in the housing for inserting a high-pressure device for testing within the housing”), 2:1–3 (“[I]ncludes a closeable access opening in the safety housing for inserting a high-pressure device for testing within the safety housing”), 2:16–18 (“[I]nserting a high-pressure device for testing within the housing through the access opening.”), 5:66–6:1 (“[I]nserting a high-pressure device for testing within the explosion-proof safety housing 11, 45 through the access opening 19.”).

As indicated, the specification does not limit or require the “opening” to be a certain size. The opening is only described as providing access for inserting a high-pressure device within the explosion-proof safety housing (11, 45). *See, id.* This does not require the opening to be a “walk-in door to the stationary housing,” as Defendant proposes. Instead, it only requires that the door 19 allows for access to the chamber 12 for insertion or placement of the device to be tested. Indeed, the second embodiment disclosed also includes similar components (*i.e.*, a low-pressure pump 41, an intermediate-pressure pump 42, a high-pressure pump 49 and a bleed valve 43), but is described as a “smaller portable enclosure or housing that may be moved to different testing sites.” ’428 Patent at 5:46–47. Because the intrinsic evidence does not limit the size of the housing 11, the “opening” to the housing will be given its full meaning. *Johnson Worldwide Assocs. v. Zebco Corp.*, 175 F.3d 985, 989 (Fed. Cir. 1999) (“General descriptive terms will ordinarily be given

their full meaning; modifiers will not be added to broad terms standing alone”). It would be improper to limit the “stationary housing” and the recited “opening” so narrowly, because it would fail to give appropriate weight to the intrinsic evidence.

Defendant argues that “[t]he closeable access opening must be one that a user can walk through if the door can be locked ‘so that no user/personnel can enter chamber 12.’” [Doc. No. 78 at 20] (citing ’428 Patent at 3:55–57). According to Defendant, “the closeable access opening ensures ‘no user/personnel’ can enter the chamber.” *Id.* Defendant argues that Plaintiff’s construction would render the limitation in the specification meaningless. *Id.* The Court disagrees. The use of the word “enter” alone does not rise to the level of manifest exclusion or restriction as to the size of the opening. *Innova/Pure Water, Inc. v. Safari Water Filtration Sys.*, 381 F.3d 1111, 1117 (Fed. Cir. 2004) (“[C]laims will not be read restrictively unless the patentee has demonstrated a clear intention to limit the claim scope using words or expressions of manifest exclusion or restriction.”) (internal citations omitted). Furthermore, Defendant’s argument neglects that “entry” could be by other means that does not require a walk-in door (*e.g.*, placing a hand/arm into the housing).

In summary, the stationary housing 11 is described in the specification as intended to “withstand and confine shock wave or shock pressure radiated by explosions,” and to allow “inserting a high-pressure device for testing within bunker housing 11.” ’428 Patent at 3:57–58, 4:4-7. The intrinsic evidence does not limit the recited “housing” to one particular size, and the terms “housing” and “opening” will be given their full meaning. Accordingly, the Court rejects Defendant’s construction because it is not supported by the intrinsic evidence. Finally, in reaching its conclusion, the Court has considered the extrinsic evidence submitted by the parties, and given it its proper weight in light of the intrinsic evidence.

**c) Court’s Construction**

The Court construes the term “**closeable access opening in said housing**” to mean “**a door in the housing which may be opened and closed for inserting a high-pressure device for testing.**”

**3. “means within said housing for coupling said high-pressure pneumatics testing equipment to said high-pressure device for testing”**

<u>Disputed Term</u>	<u>Plaintiff’s Proposal</u>	<u>Defendant’s Proposal</u>
“means within said housing for coupling said high-pressure pneumatics testing equipment to said high-pressure device for testing”	“means-plus-function term encompassing pressure containing hoses, fittings, pressure containing fittings, manifold fittings, pump fittings, and any equivalents thereto”	“means for coupling” not supported in the specification; no corresponding structure is defined or clearly indicated in the figures”

**a) The Parties’ Positions**

The parties agree that the phrase “means within said housing for coupling said high-pressure pneumatics testing equipment to said high-pressure device for testing” is subject to § 112 ¶ 6. Defendant contends that the phrase is indefinite, and argues that there is insufficient structure disclosed in the specification. Plaintiff argues that it is entitled to have the phrase construed to encompass any structures disclosed in the patent specification, as well as any equivalents thereto that perform the claimed function. [Doc. No. 73 at 23]. Plaintiff contends that “means 12a” functions for coupling the high pressure pneumatics testing equipment to the high-pressure device. *Id.* (citing ’428 Patent at 3:2–4, Figure 1). Plaintiff also contends that means for coupling high pressure pneumatics are well understood and defined as “to connect with a coupling, such as of two belts or two pipes.” *Id.* (citing Dictionary of Engineering, McGraw-Hill, 2nd ed. 2002).

Plaintiff further contends that the specification identifies plumbing structures of hoses and pumps for the purpose of coupling the high pressure pneumatics testing equipment to the high-



pressure device. *Id.* at 24 (citing '428 Patent at 3:36–38). Plaintiff argues that the term “means within said housing for coupling” did not require considerable explanation to be understood as being the hoses, pumps, manifolds, and fittings coupling the high-pressure pneumatics testing equipment to a high-pressure device for testing. *Id.*

Regarding Defendant’s construction, Plaintiff argues that Defendant attempts to invalidate the limitation as indefinite. *Id.* Plaintiff contends that it has identified the function and structure of the means-plus-function term. *Id.* Plaintiff argues that the Court should adopt its construction because it is the only construction provided. *Id.* at 25.

Defendant responds the phrase lacks support in the specification because there is no corresponding structure defined or clearly indicated in the figures. [Doc. No. 78 at 21]. Defendant argues that the claimed function is the coupling of the high-pressure pneumatics testing equipment to the high-pressure device for testing. *Id.* (citing '428 Patent at 3:1–4). Defendant contends that the term “couple” is defined as “something that joins or links two things together.” *Id.* at 21-22. (citing Merriam-Webster.com, <http://www.merriamwebster.com/dictionary/couple>). Defendant further contends that the only reference to this means is found in Figure 1, marked as 12a. *Id.* at 22. Defendant argues that the 12a reference is ambiguous and not in the form of a hose. *Id.* Defendant further contends that a patentee is only entitled to “corresponding structure . . . described in the specification and equivalents thereof,” not any device capable of performing the function. *Id.* (citing 35 U.S.C. § 112 ¶ 6; *Blackboard, Inc. v. Desire2Learn Inc.*, 574 F.3d 1371, 1385 (Fed. Cir. 2009)).

Defendant also argues that Plaintiff is only entitled to have the phrase construed to encompass only “corresponding” structures. *Id.* at 23. Defendant contends that there is no structure in the specification that corresponds to the recited function. *Id.* Defendant further

contends that whether the claim term was “well understood in the art” is irrelevant to what is disclosed in the specification. *Id.* Defendant concludes that the phrase must be found indefinite because the specification fails to disclose the requisite type of means. *Id.* at 24.

Plaintiff replies that the specification identifies the structures of “pumps, plumbing, hoses, and bleed valves” as being the articles “located entirely within chamber 12.” [Doc. No. 83 at 15] (citing ’428 Patent at 3:36–38, Figure 1). According to Plaintiff, the hoses and pumps are recited for the purpose of functioning as coupling the high pressure pneumatics testing equipment to the high-pressure device. *Id.* Plaintiff argues that “[i]t has been well-established that a specification need not disclose what is well-known in the art and that a patent need not teach, and preferably omits, what is well known in the art.” *Id.* (citing *Streck, Inc. v. Research & Diagnostic Sys., Inc.*, 665 F.3d 1269, 1288 (Fed. Cir. 2012); *Hybritech Inc. v. Monoclonal Antibodies, Inc.*, 802 F.2d 1367, 1384 (Fed. Cir. 1986)). Plaintiff further argues that structures for providing coupling to the high-pressure testing equipment are present and disclosed within the specification. *Id.* at 15-16. Finally, Plaintiff contends that Defendant has not provided the Court with a claim construction. *Id.* at 16.

#### **b) Analysis**

The phrase “means within said housing for coupling said high-pressure pneumatics testing equipment to said high-pressure device for testing” appears in asserted claims 1 and 11 of the ’428 Patent. The phrase uses the words “means . . . for” and specifies a function, thus the Court presumes that the patentees intended to invoke the statutory mandates for means-plus-function clauses. *York Prods. v. Central Tractor Farm & Family Ctr.*, 99 F.3d 1568, 1574 (Fed. Cir. 1996) (“In determining whether to apply the statutory procedures of section 112, ¶ 6, the use of the word ‘means’ triggers a presumption that the inventor used this term advisedly to invoke the statutory

mandates for means-plus-function clauses.”). Furthermore, the parties agree that the phrase is subject to § 112 ¶ 6. Accordingly, the Court finds that the phrase is governed by 35 U.S.C. § 112, ¶ 6.

“The first step in construing [a means-plus-function] limitation is a determination of the function of the means-plus-function limitation.” *Medtronic*, 248 F.3d at 1311. The parties generally agree that the function is “coupling the high-pressure pneumatics testing equipment to the high-pressure device for testing.” (73 at 23, 78 at 21). The Court agrees that the intrinsic evidence indicates that the recited function is “coupling the high-pressure pneumatics testing equipment to the high-pressure device for testing.”

Having determined the limitation’s function, “the next step is to determine the corresponding structure disclosed in the specification and equivalents thereof.” *Medtronic*, 248 F.3d at 1311. The specification indicates that the corresponding structure that performs the recited function of “coupling the high-pressure pneumatics testing equipment to the high-pressure device for testing” is plumbing and hoses. Specifically, the specification states that “[l]ocated entirely within chamber 12 is at least one high-pressure pneumatics testing equipment and means 12a for coupling the high-pressure pneumatics testing equipment to a high-pressure device for testing.” ’428 Patent at 3:1–4. The specification further states that “a majority if not all associated pumps, *plumbing, hoses*, and bleed valves are to also be located entirely within chamber 12.” *Id.* at 3:36–37 (emphasis added); *see also id.* at 5:37–39 (“[M]ost if not all associated pumps, *plumbing, hoses*, and bleed valves located entirely within chamber 44 of a testing housing 45.”) (emphasis added). A person or ordinary skill in the art would understand that the identified plumbing and hoses is the corresponding structure that performs the function of coupling the high pressure pneumatics

testing equipment to the high-pressure device.<sup>5</sup> Thus, the specification clearly indicates that the corresponding structure is the “plumbing and hoses and equivalents thereof.”

Plaintiff argues that “it is well-established that a specification need not disclose what is well-known in the art and that a patent need not teach, and preferably omits, what is well known in the art”. [Doc. No. 73 at 24] (citing *Streck, Inc. v. Research & Diagnostic Sys., Inc.*, 665 F.3d 1269, 1288 (Fed. Cir. 2012); *Hybritech Inc. v. Monoclonal Antibodies, Inc.*, 802 F.2d 1367, 1384 (Fed. Cir. 1986)). The cases cited by Plaintiff are inapposite. At issue in those cases was whether the disclosure was enabling, it was not a § 112 ¶ 6 issue. *See Streck, Inc. v. Research & Diagnostic Sys., Inc.*, 665 F.3d at 1292 (“[A] reasonable jury could not have found the patents invalid for lack of enablement by clear and convincing evidence”); *Hybritech Inc. v. Monoclonal Antibodies, Inc.*, 802 F.2d at 1384 (Fed. Cir. 1986) (“We hold as a matter of law that the ’110 patent disclosure is enabling.”). Under § 112 ¶ 6, a patentee is only entitled to “corresponding structure . . . *described in the specification* and equivalents thereof.” 35 U.S.C. § 112 ¶ 6 (pre-AIA) (emphasis added); *see also Blackboard, Inc. v. Desire2Learn Inc.*, 574 F.3d 1371, 1385 (Fed. Cir. 2009) (“That ordinarily skilled artisans could carry out the recited function in a variety of ways is precisely why claims written in ‘means-plus-function’ form must disclose the particular structure that is used to perform the recited function.”).

Turning to Defendant’s indefinite proposal, Defendant contends that there is no corresponding structure defined or clearly indicated *in the figures*. [Doc. No. 78 at 21] (emphasis added). As it is a challenge to the validity of a patent, the failure of any claim in suit to comply with § 112 must be shown by clear and convincing evidence. *Nautilus Inc. v. Biosig Instruments, Inc.*, 134 S. Ct. 2120, 2130 n.10 (2014). Defendant argues that the only reference to the recited

---

<sup>5</sup> The pumps and bleed valves are separately claimed elements. *See, e.g.*, Claims 1 and 11.

means is found in Figure 1, marked as 12a. [Doc. No. 78 at 22].

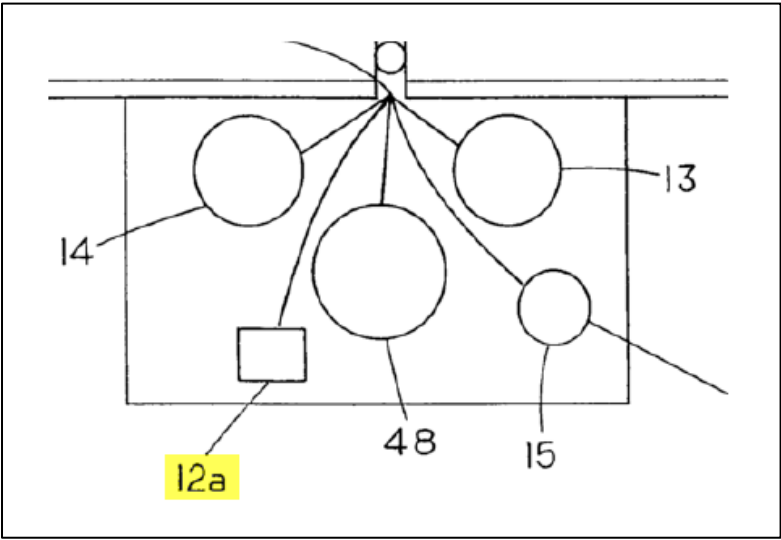

'428 Patent at Figure 1 (partial excerpt). Defendant contends that the figure only shows a nondescript box. *Id.* at 22. Defendant's analysis, however, is incomplete and ignores the corresponding structure identified in the specification. As discussed above, the specification states that "[l]ocated entirely within chamber 12 is at least one high-pressure pneumatics testing equipment and means 12a for coupling the high-pressure pneumatics testing equipment to a high-pressure device for testing," and that "a majority if not all associated pumps, *plumbing, hoses,* and bleed valves are to also be located entirely within chamber 12." '428 Patent at 3:1-4, 3:36-37 (emphasis added).

Indeed, Defendant argues in other briefing that "[a]ny tubing or hose that connects the pumps to the device to be tested would be part of the claimed 'means within said housing for coupling said high-pressure pneumatics testing equipment to said high-pressure device for testing,' and not the 'high-pressure pneumatics testing equipment' itself." [Doc. No. 240 at 9]. Accordingly, the Court finds that Defendant has failed to prove by clear and convincing evidence that the phrase is indefinite. *Intel Corp. v. VIA Techs., Inc.*, 319 F.3d 1357, 1366 (Fed. Cir. 2003) ("[Defendant] needed to prove, by clear and convincing evidence, that the specification lacks

adequate disclosure of structure to be understood by one skilled in the art as able to perform the recited functions.”).

Defendant is correct that the specification does not explicitly identify “fittings, pressure containing fittings, manifold fittings, pump fittings” as the corresponding structure. Thus, the Court rejects this portion of Plaintiff’s construction. However, this neither excludes nor includes these items as “equivalents” to the identified “plumbing and hoses.” It only indicates that these items were not identified in the specification as the corresponding structure for the recited function.

Additionally, the Court’s construction indicates that plumbing and hoses that couple the high-pressure pneumatics testing equipment to the high-pressure device for testing are not the recited “high-pressure pneumatics testing equipment.” The “high-pressure pneumatics testing equipment” is a separately claimed element from the structure for “coupling said high-pressure pneumatics testing equipment to said high-pressure device.” The plain language of the claims requires both the “high-pressure pneumatics testing equipment” and the “means . . . for coupling” to be “within said housing.” To the extent that a party contends that plumbing and hoses are the recited “high-pressure pneumatics testing equipment,” the Court rejects that argument. Finally, in reaching its conclusion, the Court has considered the extrinsic evidence submitted by the parties and given it its proper weight in light of the intrinsic evidence.

### c) Court’s Construction

In light of the evidence, the Court finds that the phrase “**means within said housing for coupling said high-pressure pneumatics testing equipment to said high-pressure device for testing**” is governed by 35 U.S.C. § 112, ¶ 6, and construes the phrase as follows:

**Function: Coupling the high-pressure pneumatics testing equipment to the high-pressure device for testing.**

**Corresponding Structure: Plumbing and hoses and equivalents thereof.**

**4. “means linking said high-pressure pneumatics testing equipment to said control panel”<sup>6</sup>**

<u>Disputed Term</u>	<u>Plaintiff’s Proposal</u>	<u>Defendant’s Proposal</u>
“means linking said high-pressure pneumatics testing equipment to said control panel”	“means-plus-function term encompassing electronic cables, data cables, audio/video cables, digital and/or analog cables, power cables, pressure containing hoses and tubing, and any equivalents thereto”	“tubing capable of communicating pressure from the control panel to the testing equipment”

**a) The Parties’ Positions**

The parties agree that the phrase “means linking said high-pressure pneumatics testing equipment to said control panel” is subject to § 112 ¶ 6. The parties dispute the corresponding structure for the phrase. Plaintiff argues that it is entitled to have the phrase construed to encompass any structures disclosed in the patent specification, as well as any equivalents thereto that perform the claimed function. [Doc. No. 73 at 25-26]. Plaintiff contends that in claims 1, 9, and, 11 of the ’428 Patent, the function of the “means linking” is to link and facilitate the function of the control panel and to operate the high-pressure testing equipment. *Id.* at 27 (citing ’428 Patent at 3:26-30, 6:40-43, 7:10-13, 7:35-38, 8:23-26). Plaintiff further argues that in claims 2, 12, and 17 of the ’428 Patent, the control panel is further defined as functioning to monitor and record the operation of the high-pressure testing equipment from the control panel. *Id.* (citing ’428 Patent at 6:45-48, 7:40-43, 8:29-31).

---

<sup>6</sup> The parties originally proposed construing the phrase “coupling said control panel to the testing equipment inside said housing” recited in claim 16 for construction. [Doc. No. 73 at 25, Doc. No. 78 at 24]. On November 20, 2018, the parties notified the Court that “claim construction is unnecessary for the phrase ‘coupling said control panel to the testing equipment inside said housing’ in claim 16 of US. Patent No. 8,146,428.” [Doc. No. 165 at 1]. Accordingly, the Court will not construe the phrase because the parties have indicated that there is not a claim construction dispute for this term.

Regarding the corresponding structure, Plaintiff contends that for claims 1, 9, and 11 the corresponding structure is “[t]ubing 17 [that] runs from the chamber 12 through a small opening 18 on bunker housing 11 to the control panel 16.” *Id.* at 28 (citing ’428 Patent at 4:12–14). Plaintiff further argues that the control panel 16 is described as comprising pump on/off switch 34, an adjustable resistor 39, and ball valve 37. *Id.* (citing ’428 Patent at 5:5–10, Figure 4). Plaintiff contends that this conforms to the description that control panel 16 operates the high-pressure pneumatic testing equipment. *Id.* (citing ’428 Patent at 3:26–31). Plaintiff further contends that the “control panel” has physical control switches, resistors, valves, etc. or their digital computational equivalent means of controlling the testing equipment. *Id.*

Plaintiff next argues that the recited structures for the limitations of claims 2, 12, and 17 are described as chart recorders and pressure gauges on the control panel. [Doc. No. 73 at 28-29] (citing ’428 Patent at 5:27–29, 5:4–7, 5:17–29, Figure 4). Plaintiff contends that in addition to the traditional chart recorders using ink pen on plain paper, heated stylus on heat sensitive paper, or light or electron beam on photosensitive paper, and pressure gauges having metallic sensing elements or piezoelectric crystals to measure pressure was well known in the field of engineering and equipment testing. *Id.* at 29 (citing Dictionary of Engineering, McGraw-Hill, 2nd ed. 2002; Doc. No. 83-2)

Plaintiff also argues that the structural equivalence for the “means for monitoring and recording” includes physical or analog pressure gauge, chart recorder, etc. or their digital and computational equivalents. *Id.* Plaintiff argues that claims of a patent generally are not strictly limited to a device described in the specifications or depicted in a drawing. *Id.* (citing *Arnold PipeRentals Co. v. Engineering Enterprises, Inc.*, 350 F.2d 885 (5th Cir. 1965); *Ziegler v. Phillips Petroleum Co.*, 483 F.2d 858 (5th Cir. 1973)). Plaintiff contends that the operation of the control



panel to turn on/off the testing equipment and allow for input of pressure is well known to require tubing and pressure containing hoses to facilitate the passage of pneumatic pressures and other electronic cables and power cables. *Id.* at 30.

Plaintiff further argues that “means linking” for a control panel 16 for monitoring and recording are well known to include analog/digital cables, data cables, audio/video cables, electronic and power cables capable. *Id.* (citing Doc. No. 83-2). Plaintiff contends that claims 1, 9, and 11 should be construed as a means-plus-function phrase comprising tubing, pressure containing hoses, electronic cables, power cables, and any equivalents thereto. *Id.* Plaintiff further contends that claims 2, 12, and 17 should be construed as a means-plus-function phrase including the previous structures as well as comprising analog/digital cables, data cables, audio/video cables, electronic and power cables, and any equivalents thereto. *Id.*

Defendant responds that the specification describes tubing being used to communicate pressure between the control panel and the testing equipment. [Doc. No. 78 at 24] (citing ’428 Patent at 4:5-15). Defendant argues that Figure 1 displays tubing (17). *Id.* at 25. According to Defendant, the construction for these terms is “tubing capable of communicating pressure from the control panel to the testing equipment.” *Id.* at 24.

Defendant further argues that the *quid pro quo* of invoking mean-plus-function is that the patentee must detail in the specification an adequate disclosure showing what is meant by that language. *Id.* at 25 (citing *B. Braun Med., Inc. v. Abbott Lab.*, 124 F.3d 1419, 1425 (Fed. Cir. 1997)). Defendant contends that the structural equivalence under § 112, ¶ 6 is met only if the differences are insubstantial. *Id.* at 26 (citing *Chiuminatta Concrete Concepts, Inc. v. Cardinal Indus., Inc.*, 145 F.3d 1303, 1308 (Fed. Cir. 1998)). Defendant argues that for the “means linking said high-pressure pneumatics testing equipment to said control panel,” Plaintiff erroneously

proposes equivalents as “electronic cables, data cables, audio/video cables, digital and/or analog cables, [and] power cables.” *Id.* Defendant contends that these items will transmit a wholly different way to achieve a wholly different result than the tubing described in the specification. *Id.* at 26-27.

Defendant argues that Plaintiff ignores that means-plus-function claims are limited to the particular structures the specification describes as performing the recited function (and their statutory equivalents), even if a person of ordinary skill in the art would know what other structures could be employed to perform the function. *Id.* at 27 (citing *Ergo Licensing, LLC v. CareFusion 303, Inc.*, 673 F.3d 1361, 1364 (Fed. Cir. 2012)). According to Defendant, the Court should disregard any exemplary language proposed by Plaintiff that lacks support in the specification. *Id.*

Plaintiff replies that Defendant’s construction are overly simplified interpretation for the structural limitations of the “means linking” and “means for monitoring and recording.” [Doc. No. 83 at 17]. Plaintiff argues that it is entitled to have the phrases construed to encompass any structures disclosed in the patent specification, as well as any equivalents. *Id.* Plaintiff repeats the argument that the function of the “means linking” in claims 1 and 11 is to link and facilitate the function of the control panel as to operate the high-pressure testing equipment. *Id.* at 18.

Plaintiff also repeats that the control panel 16 is described as comprising pump on/off switch 34, an adjustable resistor 39, and ball valve 37. *Id.* Plaintiff further contends that switches, resistors, valves, etc. or their digital computational equivalent perform the claimed function of operating the high-pressure testing equipment in substantially the same way of setting limits and sending signals from and to the high-pressure testing equipment through the cables, hoses, tubing, and other equivalent structural “means linking” to achieve substantially the same result of facilitating the high-pressure test. *Id.*

Plaintiff repeats that the recited structures for the limitations of claims 2, 12, and 17 are described as chart recorders and pressure gauges on the control panel. *Id.* Plaintiff further contends that physical or analog pressure gauge, chart recorder, etc. or their digital and computational equivalents perform the claimed function of monitoring and recording the operation of the high-pressure testing equipment in substantially the same way of receiving data and signals from the testing equipment through the cables, hoses, tubing, and equivalent structural “means linking” to achieve substantially the same result of allowing for the monitoring and recording of the test. *Id.* at 19.

Plaintiff further argues that the claims of a patent generally are not strictly limited to a device described in the specifications or depicted in a drawing. *Id.* According to Plaintiff, the specification recites multiple embodiments (*e.g.* a stationary embodiment, portable embodiment, etc.) that contain the disputed “means linking” and “means for monitoring and recording,” and recites the structure in general terms. *Id.* Plaintiff further argues that the Affidavit of Mr. Lavergne provides the Court with the state of the art at the time the ’428 Patent was filed regarding common equivalents of the “means linking/coupling” and “means for monitoring and recording.” *Id.* at 20. Plaintiff argues that the testimony of the inventor is necessary to provide the Court with the knowledge and insight of the art at the time of filing the invention. *Id.* at 22. Plaintiff contends that the Affidavit of Mr. Lavergne does not contradict the claim language, and does not contradict the import of the specification. *Id.*

#### **b) Analysis**

The phrase “means linking said high-pressure pneumatics testing equipment to said control panel” appears in asserted claims 1, 2, 9, 11, and 12 of the ’428 Patent. The phrase uses the words “means . . . for” and specifies a function, thus the Court presumes that the patentees intended to

invoke the statutory mandates for means-plus-function clauses. *York Prods. v. Central Tractor Farm & Family Ctr.*, 99 F.3d 1568, 1574 (Fed. Cir. 1996) (“In determining whether to apply the statutory procedures of section 112, ¶ 6, the use of the word ‘means’ triggers a presumption that the inventor used this term advisedly to invoke the statutory mandates for means-plus-function clauses.”). Furthermore, the parties agree that the phrase is subject to § 112 ¶ 6. The Court agrees, but finds that the parties have not identified the entire mean-plus-function limitation recited in the claims. Specifically, the claims recite “means linking said high-pressure pneumatics testing equipment to said control panel *for operating said high-pressure pneumatics testing equipment.*” *See, e.g.*, ’428 Patent at 6:40–42 (emphasis added). Accordingly, the Court finds that the phrase is governed by 35 U.S.C. § 112, ¶ 6.

“The first step in construing [a means-plus-function] limitation is a determination of the function of the means-plus-function limitation.” *Medtronic*, 248 F.3d at 1311. Plaintiff contends that the function is “to link and facilitate the function of the control panel . . . as to operate the high-pressure testing equipment.” [Doc. No. 73 at 27]. Defendant does not propose a function for the disputed term. The intrinsic evidence indicates that the recited function is “linking the high-pressure pneumatics testing equipment to the control panel to operate the high-pressure pneumatics testing equipment.” Plaintiff further contends that for claims 2, 12, and 17 the function includes “facilitate the monitoring and recording of such operation.” The Court notes that claims 2, 12, and 17 are dependent claims, and relate to the disputed phrase “means for monitoring and recording,” which is discussed in more detail below. Accordingly, the Court will address this argument when it addresses the “means for monitoring and recording” phrase.

Having determined the limitation’s function, “the next step is to determine the corresponding structure disclosed in the specification and equivalents thereof.” *Medtronic*, 248

F.3d at 1311. The specification indicates that the corresponding structure that performs the recited function of “linking the high-pressure pneumatics testing equipment to the control panel to operate the high-pressure pneumatics testing equipment” is tubing capable of communicating pressure. Specifically, the specification states that “the embodiment of FIG. 1 shows the control panel 16 *linked* to the low-pressure pump 13, intermediate-pressure pump 14, high-pressure pump 47, and the bleed valve 15 by a 1/8” 60,000 psi rate cone and reinforced thread tubing 17 with a 4 to 1 safety factor.” ’428 Patent at 4:8–13 (emphasis added). The specification further states that “[t]ubing 17 runs from the chamber 12 through a small opening 18 on bunker housing 11 to the control panel 16 and may also be reinforce by a steel piping.” *Id.* at 4:13–15.<sup>7</sup> The specification further indicates that the tubing must be capable of communicating pressure when it discloses that the pump on/off valve is “is connected to control panel 16 and is *air operated* to switch pump on/off valve 29 on and off.” *Id.* at 4:62–63 (emphasis added). Thus, the corresponding structure that performs the recited function of “linking the high-pressure pneumatics testing equipment to the control panel to operate the high-pressure pneumatics testing equipment” is tubing capable of communicating pressure.

The specification also identifies pump on/off switch 34, air regulator 35, ball valve 37, filter 38, and adjustable resistor 39 as corresponding structure for performing the recited “linking and operating” function. Specifically, the specification states the following”

FIG. 4 is a schematic view showing the general components of the control panel 16 of safety system 10 comprising a pump on/off switch 34, an air regulator 35, an air drive pressure gauge 36, a ball valve 37, and a filter 38. Pump on/off switch 34 functions by sending a pneumatic signal to the corresponding high-pressure equipment testing device to either turn on or off the particular device. Pump on/off switch 34 is shown in fluid communication with air regulator 35, which includes an adjustable resistor 39 to allow the user to control or set the amount fluid flow that is directed into control panel 16. To prevent over pressurization, air regulator

---

<sup>7</sup> The reinforced tubing is a separately claimed element. *See, e.g.*, Claim 9.

35 has the ability to automatically bleed off excess air that is directed through control panel 16.

Air regulator 35 is shown in fluid communication with ball valve 37, which functions to control the main pressure of control panel 15 on and off. Located between and in fluid communication with air regulator 35 and ball valve 37 is air drive pressure gauge 36, which similar to air drive pressure gauge 25, functions to display the pressure being directed through control panel 16. Also in fluid communication with ball valve 37 is filter 38, which functions to remove and automatically drain liquids from the air entering control panel 16.

'428 Patent at 5:4–26. Accordingly, the specification identifies pump on/off switch, air regulator, ball valve, filter, and adjustable resistor as the corresponding structure for performing the “linking and operating” function.<sup>8</sup>

Plaintiff argues that the specification identifies pump on/off switch 34, adjustable resistor 39, and ball valve 37 as the corresponding structure. [Doc. No. 73 at 28] (citing '428 Patent at 5:5-10, Figure 4). The Court agrees. The specification clearly identifies these components as the corresponding structure. '428 Patent at 5:4–7 (“FIG. 4 is a schematic view showing the general components of the control panel 16 of safety system 10 comprising a pump on/off switch 34, an air regulator 35, an air drive pressure gauge 36, a ball valve 37, and a filter 38.”).

Plaintiff also argues that “[t]he operation of the control panel 16 to turn on and off the testing equipment as well as allow for input of pressure is well known to require tubing and pressure containing hoses to facilitate the passage of pneumatic pressures and other such electronic cables and power cables which would allow for turning the pneumatic testing equipment on and off.” [Doc. No. 73 at 30]. The Court agrees that the corresponding structure is tubing and pressure containing hoses, but disagrees that the specification identifies “cables” as the corresponding structure that performs the recited “linking” function. The specification does not identify or

---

<sup>8</sup> As will be discussed in more detail below, the identified air drive pressure gauge 36 is the corresponding structure for the phrase “means for monitoring and recording.”

disclose any electronic cables and power cables. Thus, the Court rejects this portion of Plaintiff's construction. However, this neither excludes nor includes these items as "equivalents," or as even required in the operation of the control panel. It only indicates that these items were not identified in the specification as the corresponding structure for the recited "linking and operating" function.

Regarding Plaintiff's proposed "analog/digital cables, data cables, audio/video cables, electronic and power cables capable of facilitating and allowing for the operation and function of chart recording and pressure gauge devices." [Doc. No. 73 at 30]. The Court notes that the function of "monitoring and recording the operation of the high-pressure pneumatics testing equipment" is recited in dependent claims 2, 12, and 17, which is another disputed term. Accordingly, the Court will address this argument when it address that term.

Defendant's construction identifies the tubing as the corresponding structure, but omits the identified pump on/off switch, air regulator, ball valve, filter, and adjustable resistor. Thus, for the reasons stated above, the Court finds Defendant's identified structure to be incomplete. Finally, in reaching its conclusion, the Court has considered the extrinsic evidence submitted by the parties, and given it its proper weight in light of the intrinsic evidence.

### **c) Court's Construction**

In light of the evidence, the Court finds that the phrase "**means linking said high-pressure pneumatics testing equipment to said control panel for operating said high-pressure pneumatics testing equipment**" is governed by 35 U.S.C. § 112, ¶ 6, and construes the phrase as follows:

**Function: Linking the high-pressure pneumatics testing equipment to the control panel to operate the high-pressure pneumatics testing equipment.**

**Corresponding Structure: Pump on/off switch, air regulator, ball valve, filter,**

**adjustable resistor, tubing capable of communicating pressure and equivalents thereof.**

**5. “means for monitoring and recording”**

<u>Disputed Term</u>	<u>Plaintiff’s Proposal</u>	<u>Defendant’s Proposal</u>
“means for monitoring and recording”	“means-plus-function term encompassing chart recorders, monitors, screens, gauges, computers, data recording instruments, and any equivalents thereto”	“gauges and chart recorders connected to the control panel”

**a) The Parties’ Positions**

The parties agree that the phrase “means for monitoring and recording” is subject to § 112 ¶ 6. The parties dispute the corresponding structure for the phrase. Plaintiff argues that control panel 16 is shown with a chart recorder for monitoring and recording the operation of the high-pressure pneumatics testing equipment. [Doc. No. 73 at 31] (citing ’428 Patent at 5:26–29, Figure 4). Plaintiff further argues that gauge 36 is provided in the apparatus to display the pressure being directed through the control panel 16. *Id.* (citing ’428 Patent at 5:4–7, 5:17–23, Figure 4). Plaintiff contends that it was well known that chart recorders and gauges were and are incorporated as analog/digital computational programs and systems operated and executed through computers. *Id.* (citing Doc. No. 83-2). Plaintiff also contends that monitors, screens, computers, and other data recording instruments are equivalent devices and instruments which facilitate such operations. *Id.* at 32.

Defendant responds that the specification describes the control panel as “comprising a pump on/off switch 34, an air regulator 35, an air drive pressure gauge 36, a ball valve 37, and a filter 38.” [Doc. No. 78 at 29] (citing ’428 Patent at 5:4–7). Defendant argues that only the gauge (36) functions as a means for “monitoring and recording.” *Id.* (citing ’428 at 5: 22–23). Defendant also contends that the specification identifies a chart recorder as means for “monitoring and



recording.” *Id.* (citing ’428 Patent at 5:26–29).

Defendant further argues that Plaintiff again proposes improper equivalents under § 112, ¶ 6. *Id.* Defendant contends that the means-plus-function claims are limited to the particular structures the specification describes as performing the recited function (and their statutory equivalents), regardless of whether a person of ordinary skill in the art would know what other structures could be employed to perform the function. *Id.* at 30. Defendant argues that Plaintiff’s overly broad “equivalents” render its construction insupportable in light of the embodiment disclosed in the specifications. *Id.*

Plaintiff replies that Defendant’s construction are overly simplified interpretation for the structural limitations of the “means linking” and “means for monitoring and recording.” [Doc. No. 83 at 17]. Plaintiff argues that it is entitled to have the phrases construed to encompass any structures disclosed in the patent specification, as well as any equivalents. *Id.* Plaintiff repeats the argument that the function of “means for monitoring and recording” in claims 2, 12, and 17 is to facilitate the monitoring and recording of such operation. *Id.* at 18. Plaintiff also repeats that the recited structures for the limitations of claims 2, 12, and 17 are described as chart recorders and pressure gauges on the control panel. *Id.* Plaintiff further contends that physical or analog pressure gauge, chart recorder, etc. or their digital and computational equivalents perform the claimed function of monitoring and recording the operation of the high-pressure testing equipment in substantially the same way of receiving data and signals from the testing equipment through the cables, hoses, tubing, and equivalent structural “means linking” to achieve substantially the same result of allowing for the monitoring and recording of the test. *Id.* at 19.

Plaintiff further argues that the claims of a patent generally are not strictly limited to a device described in the specifications or depicted in a drawing. *Id.* According to Plaintiff, the

specification recites multiple embodiments (*e.g.*, a stationary embodiment, portable embodiment, etc.) that contain the disputed “means linking” and “means for monitoring and recording,” and recites the structure in general terms. *Id.* Plaintiff further argues that the Affidavit of Mr. Lavergne provides the Court with the state of the art at the time the ’428 Patent was filed regarding common equivalents of the “means linking/coupling” and “means for monitoring and recording.” *Id.* at 20. Plaintiff argues that the testimony of the inventor is necessary to provide the Court with the knowledge and insight of the art at the time of filing the invention. *Id.* at 22. Plaintiff contends that the Affidavit of Mr. Lavergne does not contradict the claim language, and does not contradict the import of the specification. *Id.*

#### **b) Analysis**

The phrase “means for monitoring and recording” appears in asserted claims 2 and 12 of the ’428 Patent.<sup>9</sup> The phrase uses the words “means for” and specifies a function, thus the Court presumes that the patentees intended to invoke the statutory mandates for means-plus-function clauses. *York Prods. v. Central Tractor Farm & Family Ctr.*, 99 F.3d 1568, 1574 (Fed. Cir. 1996) (“In determining whether to apply the statutory procedures of section 112, ¶ 6, the use of the word ‘means’ triggers a presumption that the inventor used this term advisedly to invoke the statutory mandates for means-plus-function clauses.”). Furthermore, the parties agree that the phrase is subject to § 112 ¶ 6. The Court agrees, but finds that the parties have not identified the entire mean-plus-function limitation recited in the claims. Specifically, the claims recite “means for monitoring and recording *the operation of said high-pressure pneumatics testing equipment.*” *See,*

---

<sup>9</sup> Claim 2 recites “means for monitoring and recording the operation of said high-pressure pneumatics testing equipment.” Claim 12 recites “means for monitoring and recording of the operation of said high-pressure pneumatics testing equipment.” Claim 17 is a method claim, and recites “the step of monitoring and recording of the operation of said high-pressure pneumatics testing equipment from said control panel.”

*e.g.*, '428 Patent at 6:47–48 (emphasis added). Accordingly, the Court finds that the phrase is governed by 35 U.S.C. § 112, ¶ 6.

“The first step in construing [a means-plus-function] limitation is a determination of the function of the means-plus-function limitation.” *Medtronic*, 248 F.3d at 1311. Plaintiff contends that the function is “to monitor and record the operation of the high-pressure testing equipment from the control panel.” [Doc. No. 73 at 27]. Defendant does not propose a function for the disputed term. The intrinsic evidence indicates that the recited function is “monitoring and recording the operation of the high-pressure pneumatics testing equipment.”

Having determined the limitation’s function, “the next step is to determine the corresponding structure disclosed in the specification and equivalents thereof.” *Medtronic*, 248 F.3d at 1311. The specification indicates that the corresponding structure that performs the recited function of “monitoring and recording the operation of the high-pressure pneumatics testing equipment” is gauges and chart recorders connected to the control panel. Specifically, the specification states that “FIG. 4 is a schematic view showing the general components of the control panel 16 of safety system 10 comprising . . . pressure gauge 36.” '428 Patent at 5:3–5.

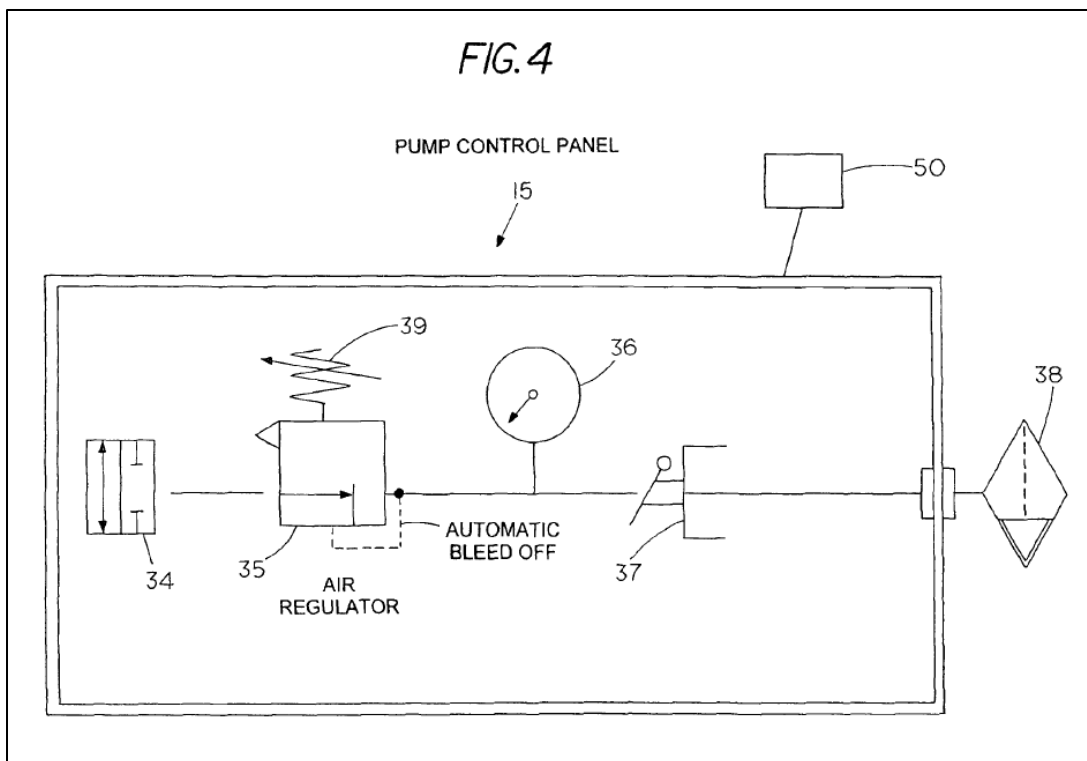

*Id.* at Figure 4. The specification states that “drive pressure gauge 36 . . . functions to display the pressure being directed through control panel 16.” *Id.* at 5:21–23. The specification further states that “[i]n the embodiment of FIG. 4, control panel 16 is shown also including means for monitoring and recording the operation of the high-pressure pneumatics testing equipment comprising a chart recorder.” *Id.* at 5:26–29. Thus, the specification clearly identifies the corresponding structure that performs the recited function of “monitoring and recording the operation of the high-pressure pneumatics testing equipment” as gauges and chart recorders connected to the control panel.

Plaintiff argues that “[t]he recited structures for the limitations of Claims 2, 12, and 17 are described as chart recorders and pressure gauges on the control panel to facilitate the monitoring and recording of the high-pressure test conducted.” [Doc. No. 73 at 28-29, 30, 31]. The Court agrees. Plaintiff further argues that the corresponding structure includes “analog/digital cables, data cables, audio/video cables, electronic and power cables capable of facilitating and allowing for the operation and function of chart recording and pressure gauge devices.” *Id.* at 30. Plaintiff

also argues that corresponding structure includes “monitors, screens, computers, and other data recording instruments.” *Id.* at 32. The Court disagrees that the specification identifies these items as the corresponding structure for the recited function.

The specification does not identify or disclose a monitor, a screen, a computer, and other data recording instrument as the corresponding structure. Thus, the Court rejects this portion of Plaintiff’s construction. However, this neither excludes nor includes these items as “equivalents,” or as even required to monitor and record the operation of the high-pressure pneumatics testing equipment. It only indicates that these items were not identified in the specification as the corresponding structure for the recited function. Finally, in reaching its conclusion, the Court has considered the extrinsic evidence submitted by the parties, and given it its proper weight in light of the intrinsic evidence.

**c) Court’s Construction**

In light of the evidence, the Court finds that the phrase “**means for monitoring and recording [of] the operation of said high-pressure pneumatics testing equipment**” is governed by 35 U.S.C. § 112, ¶ 6, and construes the phrase as follows:

**Function: Monitoring and recording the operation of the high-pressure pneumatics testing equipment.**

**Corresponding Structure: Gauges and chart recorders connected to the control panel and equivalents thereof.**

**6. “stationary housing”**

<u>Disputed Term</u>	<u>Plaintiff’s Proposal</u>	<u>Defendant’s Proposal</u>
“stationary housing”	“the housing substantially fixed in place or position”	“relatively non-movable bunker intended for movement of personnel into and out of bunker chamber”

### a) The Parties' Positions

As with the term “closeable access opening,” the parties dispute whether the housing must be “intended for movement of personnel into and out of bunker chamber,” as Defendant proposes. Thus, the only new claim construction dispute is the construction for the term “stationary.” However, the parties essentially agree on the construction for this term. Plaintiff argues that the specification does not describe “stationary” because it is a term generally understood by laypersons and those of skill in the art. [Doc. No. 73 at 32] (citing Merriam-Webster’s 11th Collegiate Dictionary 2003).

Regarding Defendant’s construction, Plaintiff argues that it attempts to read a “walk-in” limitation into the construction of the “stationary housing.” *Id.* Plaintiff contends that the closeable access opening (door 19) is only described as being provided for allowing for insertion or placing of a high-pressure device within the explosion-proof safety housing (11, 45). *Id.* at 33 (citing ’428 Patent at 3:4–7). Plaintiff argues that nothing requires the stationary housing to be capable of allowing movement of personnel into and out of the bunker chamber. *Id.* Plaintiff further argues that entry into the chamber 12 does not in and of itself suggest or describe personnel being capable of bodily going into and out of the stationary housing. *Id.* According to Plaintiff, “entry” could be by other means of entry of operators or personnel into the housing. *Id.* Plaintiff further argues that the specification does not define a size limit for housing 11. *Id.* at 34 (citing ’428 Patent at 3:57–58, 4:4–7). Plaintiff contends that limiting the stationary housing so narrowly would fail to give appropriate weight to the intrinsic evidence. *Id.*

Defendant responds that a “bunker” is defined as “a protective embankment or dugout” or “a strong building that is mostly below ground and that is used to keep soldiers, weapons, etc., safe from attacks.” [Doc. No. 78 at 30] (citing Merriam-Webster.com, <http://www.merriam-webster.com/dictionary/bunker>). Defendant argues that the stationary housing contemplates a user

being inside the bunker at times to manage the testing equipment and the device being tested, and then outside the bunker during the actual testing to protect the operator. *Id.* at 31. Defendant contends that the specification contemplates a user entering the bunker chamber. *Id.* (citing '428 Patent at 3:55–57).

Regarding Plaintiff's construction, Defendant argues that Plaintiff ignores its own use of the term "bunker." *Id.* Defendant further argues that Plaintiff's construction of "stationary housing" does not comport with Plaintiff's construction of "explosion-proof safety housing." *Id.* at 32. According to Defendant, its construction of "stationary housing" is consistent with its construction of "explosion-proof safety housing" because both define "housing" as a bunker. *Id.*

Plaintiff replies that it has no objection to the inclusion of "bunker" or "chamber" within the defining terms of "housing." [Doc. No. 83 at 22]. Plaintiff argues that "stationary housing" should be construed to mean "a case, enclosure, bunker, or chamber substantially fixed in place or position." *Id.* at 23. Plaintiff contends that Defendant's construction is based entirely on the use of the term "enter" in the specification. *Id.* (citing '428 Patent at 3:55–57). Plaintiff contends that Defendant resorts to citing the definition of a military "bunker" from Merriam-Webster's online dictionary. *Id.* at 24. Plaintiff argues that an equivalent of "bunker" is "a bin or compartment for storage." *Id.* (citing <http://www.merriam-webster.com/dictionary/bunker>). According to Plaintiff, Defendant's reliance on extrinsic evidence carries little weight for its proposition that the size of the bunker be intended for movement of personnel into and out of the bunker chamber. *Id.*

Plaintiff further argues that the word "enter" alone does not rise to the level of manifest exclusion or of restriction as to the size. *Id.* Plaintiff contends that Defendant neglects that "entry" could be by other means of entry of operators or personnel into the housing. *Id.* Plaintiff argues that the specification does not define a size limit for housing 11. *Id.* (citing '428 Patent at 3:57–

58, 4:4–7).

**b) Analysis**

The limitation of “stationary housing” appears in dependent claim 7, which depends from independent claim 1. Independent claim 1 is where the phrase “explosion-proof safety housing” initially appears, and it is dependent claim 7 that recites “[t]he safety system for testing high-pressure devices as described in claim 1 wherein said explosion-proof safety housing comprises a stationary housing.” It is understood that a claim in dependent form shall be construed to incorporate by reference all the limitations of the claim to which it refers. 35 U.S.C. § 112. Thus, “housing,” as construed by the Court in the term “explosion-proof safety housing” in claim 1, is read into the meaning of “stationary housing” for claim 7. It is redundant, unnecessary, and potentially confusing to construe the term “housing” again in this claim. Accordingly, the Court finds that the only term that requires construction is “stationary.”

The Court finds that “stationary” means “relatively non-movable or substantially fixed in place,” as proposed by the parties. As discussed, the term “stationary” appears in dependent claim 7, and indicates that the recited “explosion-proof safety housing” is “stationary.” The specification further states that “[s]afety system 10 includes a stationary explosion-proof safety housing comprising a bunker housing 11 having a chamber 12 therein.” ’428 Patent at 2:49–51.

This is in contrast to dependent claim 8, which requires the recited “explosion-proof safety housing” to be “portable.” Likewise, the specification describes the embodiment disclosed in Figure 5 as a “portable safety system.” *Id.* at 5:30–31. The specification states that “unlike the bunker housing 11 of safety system 10, which comprises a stationary enclosure, the testing housing 45 of portable safety system 40 comprises a smaller portable enclosure or housing *that may be moved to different testing sites.*” *Id.* at 5:43–47 (emphasis added). The specification adds that



“[f]or ease in transportation, the control panel 46 may be attached to an exterior surface of the test housing 45 and the housing may include wheels 47 to expedite the transport of portable safety system 40.” *Id.* at 5:47–50. This is consistent with the parties’ agreed construction that “portable housing” means “a housing that is movable or transportable to different testing sites. [Doc. No. 59 at 2]. Accordingly, the intrinsic evidence indicates that “stationary,” in contrast to “portable,” means “relatively non-movable or substantially fixed in place.” The extrinsic evidence cited by Plaintiff is consistent with the intrinsic evidence, and defines “stationary” as “not moving: staying in one place or position.” [Doc. No. 73 at 32] (citing Merriam-Webster’s 11th Collegiate Dictionary 2003).

Regarding Defendant’s construction, the Court rejects it because it attempts to read an unwarranted size limitation into the construction of the term “housing.” Defendant argues that the “stationary housing” should be construed as being “intended for movement of personnel into and out of bunker chamber.” As discussed above for the term “explosion-proof safety housing,” the stationary housing 11 is described in the specification as intended to “withstand and confine shock wave or shock pressure radiated by explosions,” and to allow “inserting a high-pressure device for testing within bunker housing 11.” ’428 Patent at 3:57–58, 4:4–7. The specification does not limit the size of housing 11. Accordingly, the Court has resolved the parties’ claim construction dispute as it relates to the size of the housing when it construed the term “explosion-proof safety housing.” For the reason discussed above, the Court rejects this portion of Defendant’s construction. Finally, in reaching its conclusion, the Court has considered the extrinsic evidence submitted by the parties, and given it its proper weight in light of the intrinsic evidence.

#### **c) Court’s Construction**

The Court construes the term “stationary” to mean “**relatively non-movable or**

**substantially fixed in place.”**

**V. CONCLUSION**

The Court adopts the above constructions. The parties are ordered to not refer, directly or indirectly, to each other’s claim construction positions in the presence of the jury. Likewise, the parties are ordered to refrain from mentioning any part of this opinion, other than the definitions adopted by the Court, in the presence of the jury. However, the parties are reminded that the testimony of any witness is bound by the Court’s reasoning in this order but any reference to claim construction proceedings is limited to informing the jury of the definitions adopted by the Court.

Monroe, Louisiana, this 10<sup>th</sup> day of June, 2019.

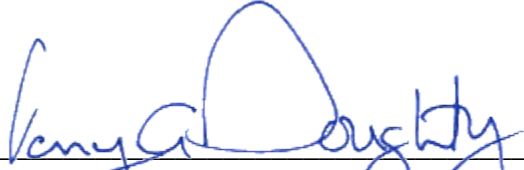
  
**TERRY A. DOUGHTY**  
**UNITED STATES DISTRICT JUDGE**