

UNITED STATES DISTRICT COURT
DISTRICT OF MASSACHUSETTS

CARDIONET, LLC, and BRAEMAR	*	
MANUFACTURING, LLC,	*	
	*	
Plaintiffs,	*	
	*	Civil Action No. 1:15-cv-11803-IT
v.	*	
	*	
INFOBIONIC, INC.,	*	
	*	
Defendant.	*	

MEMORANDUM & ORDER

December 10, 2018

TALWANI, D.J.

I. Introduction

Plaintiffs CardioNet, LLC and Braemar Manufacturing, LLC (collectively, “CardioNet”) brought this suit alleging that Defendant InfoBionic, Inc. (“Infobionic”) infringed on various patents owned by CardioNet. The parties asked the court to construe sixteen claim terms. See J. Claim Constr. and Prehr’g Statement [#243]. Prior to construing any of these claim terms, the court addressed Defendant’s Motion for Judgment on the Pleadings and Plaintiffs’ Motion for Reconsideration and concluded that the asserted claims as to United States Patent Nos. 7,212,850 (the “’850 patent”) and 7,907,996 (the “’996 patent”) are invalid under Alice Corp. Pty. Ltd. v. CLS Bank Int’l, 134 S. Ct. 2347 (2014). Mem. & Order [#289]; Mem. & Order [#312]. Also, prior to the court’s construction of the disputed terms, the Patent Trial and Appeals Board (“PTAB”) issued its Final Written Decisions in the inter partes review (“IPR”) proceeding involving United States Patent Nos. 6,225,901 (the “’901 patent”), 6,940,403 (the “’403 patent”), and RE43,767 (the “’767 patent”), finding all claims, except claim 10 of the ’403 patent, unpatentable. [’901 Patent] Final Written Decision [#259-1]; [’403 Patent] Final Written

Decision [#259-2]; [’767 Patent] Final Written Decision [#318-1]. The United States Court of Appeals for the Federal Circuit affirmed the decisions as to the ’901 patent and the ’403 patents, and Defendant reports that no appeal of the PTAB’s decision on the ’767 patent was filed. Notice 1 [#318]; Fed. Cir. J. [#318-2]. Accordingly, after reviewing the parties’ filings and holding a Markman hearing, the court issues the following construction of the three claim terms from United States Patent No. 7,099,715 (the “’715 Patent”) and five claim terms from the ’403 patent still in dispute.

II. Legal Framework

The construction of claim terms is a question of law. Markman v. Westview Instruments, Inc., 517 U.S. 370, 372 (1996) (“[T]he construction of a patent, including terms of art within its claim, is exclusively within the province of the court.”). “[T]he words of a claim ‘are generally given their ordinary and customary meaning.’” Phillips v. AWH Corp., 415 F.3d 1303, 1312 (Fed. Cir. 2005) (en banc) (citation omitted). “[T]he ordinary and customary meaning of a claim term is the meaning that the term would have to a person of ordinary skill in the art in question at the time of . . . the effective filing date of the patent application.” Id. at 1313. In construing claim terms, courts look to “the words of the claims themselves, the remainder of the specification, the prosecution history, and extrinsic evidence concerning relevant scientific principles, the meaning of technical terms, and the state of the art.” Id. at 1314 (quoting Innova/Pure Water, Inc. v. Safari Water Filtration Sys., Inc., 381 F.3d 1111, 1116 (Fed. Cir. 2004)).

A. The Language of the Claims

The claim construction analysis begins with the claims themselves. Id. at 1312. “[T]he claims of a patent define the invention to which the patentee is entitled the right to exclude.” Id. (quoting Innova, 381 F.3d at 1115). “[T]he context in which a term is used in the asserted claim

can be highly instructive.” Id. at 1314; see id. (“This court’s cases provide numerous . . . examples in which the use of a term within the claim provides a firm basis for construing the term.”). For example, “[b]ecause claim terms are normally used consistently throughout the patent, the usage of a term in one claim can often illuminate the meaning of the same term in other claims.” Id. Additionally, “the presence of a dependent claim that adds a particular limitation gives rise to a presumption that the limitation in question is not present in the independent claim.” Id. at 1315.

B. The Specification

The claims “do not stand alone” but “are part of ‘a fully integrated written instrument,’ consisting principally of a specification.” Id. at 1315 (internal citation omitted). “For that reason, claims ‘must be read in view of the specification, of which they are a part.’” Id. (quoting Markman v. Westview Instruments, Inc., 52 F.3d 967, 979 (Fed. Cir. 1995) (“Markman I”). “[T]he specification ‘is always highly relevant to the claim construction analysis. Usually, it is dispositive; it is the single best guide to the meaning of a disputed term.’” Id. (quoting Vitronics Corp. v. Conceptor, Inc., 90 F.3d 1576, 1582 (1996)).

“[T]he specification may reveal a special definition given to a claim term by the patentee that differs from the meaning it would otherwise possess. In such cases, the inventor’s lexicography governs.” Id. at 1316; see CCS Fitness, Inc. v. Brunswick Corp., 288 F.3d 1359, 1366 (Fed. Cir. 2002) (stating that an inventor may “act[] as his own lexicographer” by “clearly set[ting] forth a definition of the disputed claim term in . . . the specification”). “In other cases, the specification may reveal an intentional disclaimer, or disavowal, of claim scope by the inventor.” Phillips, 415 F.3d at 1316. Nevertheless, the court must be careful to “us[e] the specification [only] to interpret the meaning of a claim” and not to “import[] limitations from the

specification into the claim.” Id. at 1323; see also id. (“[A]lthough the specification often describes very specific embodiments of the invention, we have repeatedly warned against confining the claims to those embodiments.”). Although this distinction “can be a difficult one to apply in practice[,] . . . the line between construing terms and importing limitations can be discerned with reasonable certainty and predictability if the court’s focus remains on understanding how a person of ordinary skill in the art would understand the claim terms.” Id.

C. The Patent Prosecution History

In construing claim terms, courts should also consider the patent’s prosecution history. Id. at 1317. The prosecution history consists of the record of the proceedings before the United States Patent and Trademark Office (“PTO”), both pre- and post-issuance proceedings, and prior art cited during the examination of the patent. Id.; see Aylus Networks, Inc. v. Apple Inc., 856 F.3d 1353, 1360 (Fed. Cir. May 11, 2017) (“[e]xtending the prosecution disclaimer doctrine to [inter partes review] proceedings will ensure that claims are not argued one way in order to maintain their patentability and in a different way against accused infringers”). “Like the specification, the prosecution history provides evidence of how the PTO and the inventor understood the patent.” Phillips, 415 F.3d at 1317. The prosecution history can also provide evidence as to “whether the inventor limited the invention in the course of prosecution, making the claim scope narrower than it would otherwise be.” Id. “Yet because the prosecution history represents an ongoing negotiation between the PTO and the applicant, rather than the final product of that negotiation, it often lacks the clarity of the specification and thus is less useful for claim construction purposes.” Id. As a result, courts must “not rely on the prosecution history to construe the meaning of the claim to be narrower than it would otherwise be unless a patentee limited or surrendered claim scope through a clear and unmistakable disavowal.” 3M Innovative

Props. Co. v. Tredegar Corp., 725 F.3d 1315, 1322 (Fed. Cir. 2013); see Aylus Networks, 856 F.3d at 1360.

D. Extrinsic Evidence

Extrinsic evidence “consists of all evidence external to the patent and prosecution history, including expert and inventor testimony, dictionaries, and learned treatises.” Phillips, 415 F.3d at 1317 (quoting Markman I, 52 F.3d at 980). “[W]hile extrinsic evidence can shed useful light on the relevant art, . . . it is less significant than the intrinsic record in determining the legally operative meaning of claim language.” Id. (internal quotation marks and citation omitted). This is because extrinsic evidence suffers from several defects, including its independence from the patent, potential bias, and varying relevance. Id. at 1318-19. Such evidence is therefore “unlikely to result in a reliable interpretation of patent claim scope unless considered in the context of the intrinsic evidence.” Id. at 1319.

IV. Analysis

A. Disputed Terms in the '715 Patent

The '715 patent, titled “Distributed Cardiac Activity Monitoring with Selective Filtering,” is directed to optimizing the identification of R waves in the QRS complex of an electrocardiogram by selectively activating a T wave filter. '715 Patent col. 1, ll. 17-21, col. 2, ll. 52-55 [#225-2]. The '715 patent explains that a person’s heart rate cycle has certain generally recognized waveforms, that identification of heartbeats is often accomplished by identifying the “R wave” in the QRS complex, and that abnormal “T waves” may interfere with this identification. When activated, the system “filters” out T waves. Pls.’ Suppl. Opening Claim Constr. Mem. (“Pls.’ Claim Constr. Mem.”) 5 [#224]; Def.’s Suppl. Prelim. Claim Constr. Br. (“Def.’s Claim Constr. Br.”) 3 [#225]; '715 Patent col. 1, ll. 17-21, col. 3, ll. 53-60 [#225-2]. The

use of the disputed terms in Claim 1 is as follows:

A machine-implemented method comprising: identifying heart beats in a sensed cardiac signal; **activating** a [**frequency domain T wave filter**],¹ used in said identifying heart beats, in response to a message from a monitoring station generated at least in part based upon discovery of a **predetermined characteristic** in the sensed cardiac signal; and outputting information corresponding to the identified heart beats to a communications channel of a distributed cardiac activity monitoring system.

'715 Patent col. 6, ll. 27-37 [#225-2] (emphasis added).

1. “activating” and “activates” and “activate”

The terms “activating,” “activates” and “activate” appears in claims 1, 11 and 20 of the '715 patent. Id.; id. at col. 7, ll. 4-18, 45-53. CardioNet contends that these terms are commonly understood words, and that no construction is necessary as the plain and ordinary meaning applies. Pls.' Claim Constr. Mem. 21 [#224]. InfoBionic agrees that the terms are commonly understood but asserts that “[i]n the context of the ‘715 patent,” the plain meaning of “activate” is “turn on,” and that “activating,” “activates,” and “activate” should be construed as “turning on,” “turns on,” and “turn on.” Def.'s Claim Constr. Br. 9 [#225]. CardioNet responds that this understanding presupposes that the filter is a separate device that needs to be “turned on” while the filter can be a software component that is “activated,” but not necessarily “turned on” after the device has already been turned on. Pls.' Claim Constr. Mem. 21 [#224]. In CardioNet's view, InfoBionic's construction would exclude an embodiment where the filter is always “turned on,” such that “activating” is choosing between an already-filtered signal and an un-filtered signal. Id. at 21-22. InfoBionic, in turn, contends that CardioNet seeks to avoid construing the term so that it can argue that a filter that is functional but not activated meets the claim language. Def.'s

¹ The original term “T wave filter frequency domain” was corrected to “frequency domain T wave filter” by a certificate of correction. '715 Patent Certificate of Corr. 1 [#154-4].

Claim Constr. Br. 9 [#225].

“The plain meaning of claim language ordinarily controls.” InterDigital Commc’ns, LLC v. Int’l Trade Cmm’n, 690 F.3d 1318, 1324 (Fed. Cir. 2012). Here, “activate” has a plain meaning that would exclude a filter that is “not activated.” InfoBionic’s construction requiring the filter to be “turned on,” rather than merely “activated,” does not follow from the claim language.

The parties’ primary arguments are focused on the specifications. One exception to the general rule that the plain meaning controls is when a patentee disavows the full scope of a claim term either in the specification or during prosecution. Aventis Pharma S.A. v. Hospira, Inc., 675 F.3d 1324, 1330 (Fed. Cir. 2012) (quoting Thorner v. Sony Comput. Entm’t Am. LLC, 669 F.3d 1362, 1365 (Fed. Cir. 2012)). The court finds no such disavowing intent here.

InfoBionic notes the use in the specifications of the words “turn on” to refer to the T wave filter being “activated.” Def.’s Claim Constr. Br. 9 [#225] (citing ’715 Patent col. 5, ll. 30-33; col. 3, ll. 24-27 [#225-2]). But the specification also includes alternatives that do not use the phrase “turn on”: for example, “the selector [marked 240 in the figure] can be analog, selective activation circuitry that selects one of its two inputs (from the signal amplifier [marked 220 in the figure] and from the T wave filter [marked 230 in the figure]) to be provided to the beat detector [marked 250 in the figure].” Id. col. 3, ll. 20-24. That one embodiment includes activating the device by turning the filter on and off does not preclude activating the device by selecting one of multiple inputs. Rather than limit the full scope of the claim, the specifications disclose an exemplary approach to activating a T wave filter that would be limited by InfoBionic’s approach.

Accordingly, the court construes the claim terms “activating” / “activates” / “activate” in

accordance with their plain and ordinary meanings and does not limit the terms to “turning on.”

2. “frequency domain T wave filter”

The term “frequency domain T wave filter” also appears in claims 1, 11, and 20 of the Id. Col. 6, ll. 27-37; col. 7, ll. 4-18, 45-53; ’715 Patent Cert. of Correction 1 [#154-4]. CardioNet proposes that the term “frequency domain T wave filter” be construed as “filter that reduces the relative size of the T-wave in the signal based on the frequencies in the signal.” Pls.’ Claim Constr. Mem. 22 [#224]. In CardioNet’s view, the filter is not limited to reducing the amplitude of low frequency signals. Instead, the “frequency domain T wave filter” could reduce the low frequency signals, increase the amplitude of higher frequency signals, or both. Id. at 22-23. Conversely, InfoBionic contends that the term should be construed as “filter in the frequency range where the T wave is mostly located.” Def.’s Claim Constr. Br. 10 [#225]. InfoBionic argues the claim term is limited to a filter in the frequency range where the T-wave is found (i.e., low-frequency signals). Id. at 11.

The language of the claims is more consistent with CardioNet’s proposed construction than InfoBionic’s proposed construction. “The presence of a dependent claim that adds a particular limitation gives rise to a presumption that the limitation is not present in the independent claim.” Phillips, 415 F.3d at 1315. Here, there are a number of dependent claims that add particular limitations. Dependent claim 4 of the ’715 patent, for example, describes a filter that “reduces signal amplitude at low frequencies,” i.e., the frequency range where the T wave is mostly located. Dependent claim 7, in contrast, describes a filter that “has a frequency response of about +2 dB or more in a high frequency range of twenty to twenty-five Hertz”; or, in other words, increases the signal amplitude at high frequencies. Adopting InfoBionic’s proposed construction would render language in the dependent claim 4 superfluous, add a

dependent claim's limitation into an independent claim, and ignore altogether dependent claim 7.

The claim specifications also support CardioNet's construction. The specifications state that "[t]he filter can be such that it reduces signal amplitude at low frequencies of the sensed cardiac signal and increases signal amplitude at high frequencies of the sensed cardiac signal." '715 Patent col. 4, ll. 20-23; see also col. 3, ll. 57-60 ("The T wave filter [] can reduce the amplitude of T waves, while preserving or slightly increasing the amplitude of R waves" (emphasis added)). InfoBionic argues that the specifications never describe an embodiment that does not also include the reduction of signal amplitude at low frequencies. But regardless, InfoBionic's reading ignores language in both dependent claim 7 and the specifications that contemplated increasing the amplitude of R waves to reduce the relative size of the T waves.

InfoBionic argues that the prosecution history supports its construction. InfoBionic points to CardioNet's statement that a prior art reference that "reduces signal amplitude at high frequencies" is "the opposite of T wave filtering." Def.'s Claim Constr. Br. 13 [#225] (quoting Resp. to Action of Sept. 22, 2005 10 [225-8]). In InfoBionic's view, this statement shows that CardioNet "defined a T wave filter as a filter that reduces signal amplitude at low frequencies." Id. at 11 [#225]. But CardioNet's statement that the prior art reducing signal amplitude at high frequencies is opposite from the T wave filter is entirely consistent with its construction that the filter not only reduces signal amplitudes at low frequencies, but that it also may increase signal amplitude at high frequencies.

InfoBionic also contends that the "frequency domain" nature of the T wave filter was critical to the allowance of the claims, noting that the PTO had rejected the claims until CardioNet agreed to alter the claim language "T wave filter" "to specifically claim a frequency domain T wave filter." Id. (quoting Examiner-Initiated Interview Summ. Cont. Sheet [#225-9],

Notice of Allowability, Examiner's Am. [#225-10]). In InfoBionic's view, "frequency domain" refers to the frequency range where the T wave is mostly located. But the cited documents make no distinctions between the frequency range where T waves are located versus other frequency ranges. Instead, they contrast "the frequency domain" at issue in CardioNet's patent versus the "time domain" at issue in the prior reference. That the filter is focused on frequencies is apparent in CardioNet's proposed construction where the relative size reduction is achieved "based on the frequencies in the signal."

Finally, InfoBionic relies on dictionary definitions to argue that CardioNet's construction seeks to "analyze T waves" rather than filtering them out, while InfoBionic's focus on the low frequency range where the T wave is mostly located is consistent with the plain meaning of the word "filter." But the claim language and specification support the proposition that the T-wave filter can filter out the T-wave in the cardiac signal by reducing the amplitude of low frequency signals where T-waves are likely, increasing the amplitude of other frequency signals where T-waves are unlikely, or both.

Accordingly, the court construes the claim term "frequency domain T wave filter" as a "filter that reduces the relative size of the T-wave in the signal based on the frequencies in the signal."

3. "a predetermined characteristic" and "a predetermined criteria"

The term "a predetermined characteristic" / "a predetermined criteria" appears in a claim 1 and 11 of the '715 patent. '715 Patent col. 6, ll. 27-37; col. 7, ll. 4-18 [#225-2]. CardioNet contends that the claim language does not limit the predetermined characteristic to a predetermined characteristic of the T wave, and that the term should be given its plain and ordinary meaning. In CardioNet's view, the filter may be activated when any abnormal cardiac

signal is detected, such as more generalized irregularities caused by atrial fibrillation. Pl.'s Claim Constr. Mem. 24 [#224]. InfoBionic argues that regardless of any broader meaning in the abstract, since the claims require that the decision to activate the T wave filter be based, at least in part, on the predetermined characteristic, activating the T wave filter must address the predetermined characteristic. Def.'s Claim Constr. Br. 15 [#225]. InfoBionic argues further that the only characteristic or criteria disclosed by the '715 patent is "an abnormal (e.g., tall) T wave," and accordingly, InfoBionic proposes that the term be construed as "an abnormal (e.g., tall) T wave." Id. at 16.

CardioNet argues in response that this construction would exclude several embodiments disclosed in the specifications. As an example, CardioNet points to language that "[a] T wave filter is selectively activated in response to discovery of a predetermined characteristic in the sensed cardiac signal." '715 Patent col. 4, ll. 11-13 [#225-2]. But this generality is immediately followed by a specific example: "[t]he discovery of the predetermined characteristic can involve an operator's identification of a tall T wave in at least a portion of the sensed cardiac signal." Id. at col. 4, ll. 13-16.

In seeking to identify the predetermined characteristic of the sensed cardiac signal without reference to the T wave, CardioNet cites language in the specifications referencing "signal morphology analysis, an atrial fibrillation/atrial flutter (AF) detector, AF decision logic, and an event generator." Pls' Claim Constr. Mem. 24 [#224] (quoting '715 Patent col. 3, ll. 44-46. [#225-2]; Pls.' Rebuttal Claim Constr. Mem. 15 [#241] (same)). But, with a bit more context, it is evident that the cited language is not identifying the sensed cardiac signal but additional "logic." The specifications state:

The beat detector [marked 250 in the figure] can provide information regarding the time period between ventricular contractions to additional logic [marked 260 in the figure]. The additional logic [marked 260 in the figure] can include logic to determine if an abnormal T

wave potentially is occurring based on signal morphology analysis, an atrial fibrillation/atrial flutter (AF) detector, AF decision logic, and an event generator.

'715 Patent col. 3, ll. 40-46 [#225-2]. The referenced figure 2 (set forth below) underscores that the additional logic is in addition to, and not a characteristic of, the sensed cardiac signal detected by the beat detector [marked 250 in the figure].

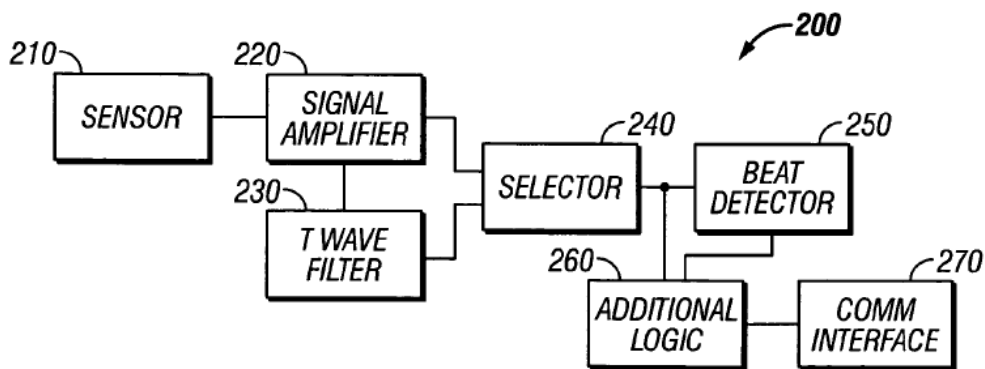

FIG. 2

That the “signal morphology analysis, an atrial fibrillation/atrial flutter (AF) detector, AF decision logic, and an event generator” are in addition to, and not a characteristic of the sensed cardiac signal is consistent with the claim language itself, which contemplates that the T wave filter is activated “in response to a message from a monitoring station generated at least in part based upon discovery of a predetermined characteristic in the sensed cardiac signal.” *Id.* at col. 6, ll. 27-36 (emphasis added); see also *id.* at col. 7, ll. 4-8 (referencing an apparatus to activate the T wave filter “based at least in part upon a predetermined criteria” (emphasis added)).

InfoBionic also points to the prosecution history, asserting that the Examiner understood the “predetermined characteristic” referred to “the identification of a tall T wave in a portion of a sensed cardiac signal.” Def.’s Claim Constr. Br. 16 [225] (citing Office Action of Sept. 22, 2005 4 [#225-11]). CardioNet offers no rebuttal to this reading of the prosecution history.

In light of the more generalized references in the specifications to an “abnormal T wave,” the court does not fully adopt InfoBionic’s definition, but does find that the characteristic must be tied to the T wave. Accordingly, the court construes the term “a predetermined characteristic” / “a predetermined criteria” as “a predetermined characteristic of the T wave” / “a predetermined criteria of the T wave.”

B. Disputed Terms in the ’403 Patent

The ’403 patent is directed to remote mobile monitoring. A centralized station controls a remote monitor to monitor subjects at a different location. See ’403 Patent col. 3, ll: 24-34 [#136-1]; ’901 Patent col. 2, ll. 1-5 [#136-2]. CardioNet argued at the Markman Hearing that the centralized control of portable units was a new concept, see Markman Hr’g Tr. 8 [#300], but the PTAB subsequently found all claims except claim 10 unpatentable on grounds of obviousness. [’403 Patent] Final Written Decision 33 [#259-2]. The remaining claim, claim 10, claims:

The apparatus of claim 1, wherein the request signal from the external source comprises a periodic status query from the **central monitoring device**.

’403 Patent col. 10, ll. 9-11 [#136-1] (emphasis added). Because claim 10 depends on claim 1, the disputed terms in claim 1 remain at issue.

Claim 1 claims:

Apparatus for remotely monitoring and assessing the status of a human subject, the apparatus comprising:

at least one **automatic sensor** associated with and monitoring the condition of the human subject; and

a **portable monitoring unit** capable of communicating with a **central monitoring device**, the **portable monitoring unit** comprising:

a programmable microprocessor in communication with the at least one **automatic sensor**, the microprocessor being **responsive to the occurrence of any of a set of activating parameters**, the activating parameters selected from the group consisting of a preselected state of the at least one **automatic sensor** and a request signal from an **external**

source,

a first transceiver in communication with the microprocessor, for communicating signals between the microprocessor and the **central monitoring device**, and

a power supply connected to provide power to the microprocessor and to at least one of the microprocessor and the first transceiver.

Id. col. 9, ll. 26-46 (emphasis added).

The disputed term “central monitoring device” appears in both claim 10 and claim 1. The disputed terms “automatic sensor,” “portable monitoring unit,” “responsive to the occurrence of any of a set of activating parameters,” and “external source” appear in claim 1.

1. **“central monitoring device”**

CardioNet contends that no construction is needed for this term and that the plain and ordinary meaning applies. Pls.’ Claim Constr. Mem. 13 [#224]. InfoBionic proposes the term be construed as “[a] central computer or terminal used for monitoring,” emphasizing that the term is singular, and not plural. Def.’s Claim Constr. Br. 16-17 [#225].

InfoBionic contends that the “central monitoring device” should be construed as a means-plus-function term under the former 35 U.S.C. § 112, ¶ 6.² That paragraph provided:

An element in a claim for a combination may be expressed as a means or step

² As set forth in Williamson v. Citrix Online, LLC, 792 F.3d 1339, 1343 n.2 (Fed. Cir. 2015) (en banc), 35 U.S.C. § 112 was amended and subsections were renamed by the America Invents Act, Pub. L. No. 112–29 (“AIA”), which took effect on September 16, 2012. In considering a patent for which the application was filed before that date, the court uses the pre-AIA version of § 112. Id. Here, the ’403 patent was issued prior to 2012.

for performing a specified function without the recital of structure, material, or acts in support thereof, and such claim shall be construed to cover the corresponding structure, material, or acts described in the specification and equivalents thereof.

The claims here do not include the word “means,” and accordingly, the court begins with the rebuttable presumption that the § 112, ¶ 6 does not apply. Williamson v. Citrix Online, LLC, 792 F.3d 1339, 1348 (Fed. Cir. 2015) (en banc). InfoBionic may overcome this presumption by demonstrating that the claim term, as understood by persons of ordinary skill in the art “fails to ‘recite sufficiently definite structure’ or else recites ‘function without reciting sufficient structure for performing that function.’” Id. (quoting Watts v. XL Sys., Inc., 232 F.3d 877, 880 (Fed. Cir. 2000)).

InfoBionic argues that the term “device” and the term “monitoring device” are words that do not themselves connote sufficiently definite structure, and that nothing in the claims describe the structure. Def.’s Claim Constr. Br. 17-18 [#225]. CardioNet objects that InfoBionic is disregarding the “central monitoring” portion of the phrase and is merely asserting that the term “device” is ambiguous. Pls.’ Rebuttal Claim Constr. Mem. 8 [#241]. But, the inclusion of these words, that the claim term modifies “device” by its function (monitoring) and location (central), offers little about the structure used to accomplish the claimed function. CardioNet’s description of the term in earlier briefing (before InfoBionic flagged the “means-plus-function” issue) focused on this very function and location, but not on structure. There CardioNet asserted that “[a] person of ordinary skill in the art would have understood that the phrase ‘central monitoring,’ as used in the claims, refers to the process of watching, keeping track of, or checking on a remote subject from a central location so that responsive action can be taken while monitoring.” Pls.’ Claim Constr. Mem. 12 [#224]; see also id. (citing InfoBionic’s expert agreement that “central monitoring” is the “process of watching patients from a central location.”

(emphasis added, emphasis in original removed)). Accordingly, the court finds that the term “central monitoring device” fails to recite sufficiently definite structure, that the presumption against means-plus-function claiming is rebutted, and that the limitation is subject to the provisions of § 112, ¶ 6.

Where § 112, ¶ 6 applies, the scope of the claim is limited “to only the structure, materials, or acts described in the specification as corresponding to the claimed function and equivalents thereof.” Williamson, 792 F.3d at 1347. The disclosures relating to the central monitoring device in the specifications provide as follows:

Typically, the central monitoring device **14** further includes a terminal **52** having a communications device interface **58** to the second transceiver **50**, and connections to a display **54** that may be viewed by an operator **56**. The terminal **52** may be a simple manual system, or preferably, it may be more complex as illustrated. In this more complex terminal **52**, there is a computer **60** that communicates with the display **54** and communicates with and oversees the operations of the portable monitoring unit **12** in the manner to be discussed subsequently . . . [T]he central monitoring device [may be] movable or portable.

. . .

There are two types of . . . central monitoring devices illustrated [in figure 2], a central monitoring device **14a** in wireless communication with the cell site **70**, and a central monitoring device **14b** in land-line communication with the cell site **70** through the central office **72**. The central monitoring devices **14a** would typically be mobile units, while the central monitoring device **14b** would typically be a stationary unit. This architecture allows central monitoring devices **14** to be used in a wide variety of application and to monitor many different portable units **12**, of the same or different types and applications.

'901 Patent col. 5, ll. 36-45, 47-48; col. 6, ll. 4-14 [#136-2]. The parties disagree whether this limits the term “central monitoring device” to a single computer or terminal, or multiple components. But the language repeatedly references “central monitoring devices” in the plural form when referencing those devices in wireless communication, and moreover, the disclosed embodiment in figure 2 shows multiple of those units or devices (marked as **14a**) as being in communication with each other as a system of computers. It is only the central monitoring device

in land-line communication (**14b**), that appears as a single unit. Accordingly, although the court agrees with InfoBionic that the term “central monitoring device” should be construed as a means-plus-function term, the court nonetheless agrees with CardioNet that the term is not limited to a central monitoring device of just a singular computer or terminal. Accordingly, the court gives the term its plain and ordinary meaning.

2. **“automatic sensor”**

Again, CardioNet contends that no construction is needed, and the plain and ordinary meaning applies. InfoBionic asserts that the term must be construed as “[a] sensor that includes a microprocessor capable of responding to an external request signal.” Def.’s Claim Constr. Br. 19 [#225]. InfoBionic’s argument rests solely on CardioNet’s representations to the PTO during IPR.

In making this argument, InfoBionic contends in part that “it is unjust to permit CardioNet to pursue narrow interpretations of the term in the IPRs to try to preserve validity and then argue a broader interpretation in court to pursue alleged infringement.” *Id.* at 20. Moreover, InfoBionic asserts that if CardioNet prevails in the IPR, it should be estopped from asserting a broader claim construction here. *Id.* (citing B&B Hardware, Inc. v. Hargis Indus., Inc., 135 S. Ct. 1293, 1306 (2015)). The difficulty with the “unjust result” argument is that CardioNet did not succeed in preserving the validity of the claim or obtain any claim allowance by its proposed limiting language. Instead, after noting that the parties had agreed there that “automatic” means “self-acting,” and that “sensor” is a “device that responds to a physical stimulus . . . and transmits a resulting impulse,” the PTO determined that the term “is not further limited to a device that includes processing ability.” [’403 Patent] Final Written Decision 11 [#259-2]. With this construction, the PTO determined that prior art included an “automatic sensor” of the type

required by claim 1, and that the claim was invalid. Id.

InfoBionic's further argument that CardioNet should be bound by its statements as "unambiguous disclaimers" is undermined by its choice of somewhat different language than that used by CardioNet in the PTO proceeding. There, CardioNet and its expert argued that "a person of ordinary skill in the art would understand that an 'automatic sensor' must have some processing capability that allows it to take some action, e.g., send or respond to a request signal." Fernald Dec. 15 [#225-14]; see also '901 Patent Owner Resp. 30-31 [#226-3]. But to state that the sensor must have "processing capability that allows it to take some action, e.g., send or respond to a request signal," without any further definition of "processing capability" is not the same as the requirement for a "microprocessor" that InfoBionic seeks here.

Finally, although the standard is different in an IPR proceeding, where the PTO seeks "the broadest reasonable interpretation in light of the specification of that patent," the parties have pointed to nothing (other than CardioNet's purported disclaimer in the IPR proceeding) that would lead to a different construction of the term. Accordingly, the court adopts the PTO's construction of the term as a "self-acting device that responds to a physical stimulus . . . and transmits a resulting impulse."

3. "portable monitoring unit"

Again, CardioNet contends that no construction is necessary for this term and that the plain and ordinary meaning applies. Pls.' Claim Constr. Mem. 15-16 [#224]. InfoBionic proposes that the term be construed instead as "[a] device that has the ability to analyze, make decisions, and take action based on an analysis of signals from the automatic sensor." Def.'s Claim Constr. Br. 22-23 [#225].

CardioNet argues that the term is already defined in the claims themselves, and thus

needs no further definition. Indeed, claim 1 dictates that the portable monitoring unit is comprised of three separate components (a programmable microprocessor, a transceiver, and a power supply) and explains further that through these components, the portable monitoring unit acts on and analyzes data from the automatic sensor. CardioNet argues that construction is therefore unnecessary. It asserts further that InfoBionic's proposed language is too narrow.

InfoBionic argues that its proposed language is taken verbatim from the patentee's description of the "portable monitoring unit" in the prosecution history of the '901 patent. Def.'s Opening Claim Constr. Br. 8 [#128]. There, the patentee contended that "[t]he portable monitoring unit has the ability to analyze, make decisions, and take action based on the analysis of the signals from the sensors, in order to determine whether to establish communications with the central monitoring device, what actions to take regarding the person being monitored, and the like." Patent Appl. 74 [#128-6]. The patentee argued further that an important conceptual difference between the patentee's system and the prior art is that "the portable monitoring unit has the ability to make decisions regarding subject condition, and take responsive action, based on information gathered from the various sensors." *Id.* at 75. InfoBionic contends that these statements limit the claim term, "[s]ince, by distinguishing the claimed invention over the prior art, an applicant is indicating what the claims do not cover, he is by implication surrendering such protection." Def.'s Opening Claim Constr. Br. 10 [#128] (quoting *Ekchian v. Home Depot*, 104 F.3d 1299, 1304 (Fed. Cir. 1997)). The court, however, must not just determine whether the issue was raised during the claim prosecution, but must determine if the patentee clearly and unmistakably disavowed the claim scope. *3M Innovative Proprs. Co.*, 725 F.3d at 1322. Here, there is no dispute that the claim requires a portable monitoring unit to potentially be responsive to the automatic sensor. That is, that the portable monitoring unit, rather than the sensor, requires

a microprocessor. Markman Hr’g Tr. 30:14-31:10 [#300]. It is not clear, however, what additionally was purportedly disavowed.

Moreover, the construction sought by InfoBionic would result in superfluous language, as the functionality InfoBionic seeks to include is separately set forth in the claim itself. Accordingly, the court agrees that the plain and ordinary meaning of the term applies.

4. “responsive to the occurrence of any of a set of activating parameters”

CardioNet contends no construction of this term is necessary and that the plain and ordinary meaning applies. Pls.’ Claim Constr. Mem. 16 [#224]. InfoBionic contends that the term should be construed as “[c]onfigured to change to (or continue in) an active state of relatively higher power consumption if one of a set of activating parameters occurs” as that is the only disclosed responsive act. Def.’s Claim Constr. Br. 23 [#225].

CardioNet argues that the claim simply requires that the microprocessor be “responsive to” any of “the listed activating parameters,” and that “responsive” is not limited. Pls.’ Opening Claim Constr. Mem. 22 [#129]. CardioNet objects that InfoBionic’s proposed construction, tying “responsiveness” of the microprocessor to an “active state of relatively higher power consumption,” would render the language of claim 4 (which claims the apparatus of claim 1 where the programmable microprocessor “has an active state and inactive state”) superfluous. Pls.’ Claim Constr. Mem. 16-17 [#224]. But claim 1 does claim that the microprocessor be “responsive to . . . activating parameters.” ’403 Patent col. 9, ll. 35-37 [#136-1] (emphasis added), and the plain and ordinary meaning of those words includes the notion of changing to or continuing in an active state. What distinguishes claim 4 then is that the claimed microprocessor there has an “inactive” state, while claim 1 could apply to a microprocessor that merely continues in an active state in response to the activating parameters.

But, while the court agrees with InfoBionic that the “response” is related to “changing or

continuing in an active state,” and that an active state uses more energy than an inactive state, the proposed construction is unnecessary. The court finds that because the term as stated limits the parameters to which the microprocessor must respond to “activating parameters,” no further construction is needed, and the plain and ordinary meaning applies.

5. “external source”

CardioNet again contends that the plain and ordinary meaning applies, while InfoBionic contends that the term should be construed as “[a] source other than the portable monitoring unit itself.” Pls.’ Opening Claim Constr. Mem. 21 [#129]; Def.’s Claim Constr. Br. 23 [#225]. While this dispute may have mattered as to claim terms that have now been invalidated by the PTAB, the dispute does not matter as to claim 10, which limits the external source to “a periodic status query from the central monitoring device.” Given that limitation in the claim itself, InfoBionic’s proposed construction is unnecessary. The court finds that the plain and ordinary meaning applies. Accordingly, the court construes the disputed terms still at issue as follows:

1. “activating,” “activates” and “activate” in claims 1, 11 and 20 of the ’715 patent are given their plain and ordinary meanings;
2. “frequency domain T wave filter” in claims 1, 11 and 20 of the ’715 patent is construed as a “filter that reduces the relative size of the T-wave in the signal based on the frequencies in the signal”;
3. “a predetermined characteristic” and “a predetermined criteria” in claim 1 and 11 of the ’715 patent are construed as “a predetermined characteristic of the T wave” and “a predetermined criteria of the T wave”;
4. “central monitoring device” in claims 1 and 10 of the ’403 patent is given its plain and ordinary meaning;
5. “automatic sensor” in claim 1 of the ’403 patent is construed as a “self-acting

device that responds to a physical stimulus . . . and transmits a resulting impulse”;

6. “portable monitoring unit” in claim 1 of the ’403 patent is given its plain and ordinary meaning;

7. “responsive to the occurrence of any of a set of activating parameters” is given its plain and ordinary meaning; and

8. “external source” is given its plain and ordinary meaning.

IT IS SO ORDERED.

Date: December 10, 2018

/s/ Indira Talwani
United States District Judge