

Exhibit 10

Not Reported in F.Supp.2d, 2009 WL 3536616 (E.D.Mich.)
(Cite as: **2009 WL 3536616 (E.D.Mich.)**)

H

Only the Westlaw citation is currently available.

United States District Court,
E.D. Michigan,
Northern Division.
SAGINAW PROPERTY, LLC, Plaintiff,
v.
VALUE CITY DEPARTMENT STORES, LLC and
Retail Ventures, Inc., Defendants.

No. 08-13782-BC.
Oct. 30, 2009.

West KeySummaryGuaranty 195 30

195 Guaranty

195II Construction and Operation

195k29 Parties

195k30 k. In general. [Most Cited Cases](#)

Corporations and Business Organizations 101
3656

101 Corporations and Business Organizations

101XV Unincorporated Business Organizations

101XV(E) Limited Liability Companies

101k3656 k. Mergers, acquisitions, and
reorganizations. [Most Cited Cases](#)

(Formerly 241Ek27 Limited Liability Companies)

A parent limited liability company was not liable for the unpaid rent payments of a bankrupt subsidiary company under a guaranty agreement that was executed to support the subsidiary's lease. The parent acquired the subsidiary through a reverse triangular merger and was therefore not a party to the guaranty or liable as a successor to the subsidiary's original parent company.

[Stuart H. Teger](#), Honigman, Miller, Detroit, MI, for Plaintiff.

[Scott R. Knapp](#), Dickinson Wright, Lansing, MI, for Defendant.

ORDER GRANTING DEFENDANT RETAIL VENTURES MOTION FOR SUMMARY JUDGMENT. DENYING PLAINTIFF SAGINAW PROPERTY'S MOTION FOR SUMMARY JUDGMENT AS TO LIABILITY. AND DISMISSING PLAINTIFF'S CLAIMS AGAINST RETAIL VENTURES WITH PREJUDICE

THOMAS L. LUDINGTON, District Judge.

*1 Plaintiff Saginaw Property, LLC (“Saginaw Property”) filed a complaint seeking to recoup rental payments from Defendants Value City Department Stores, LLC (“Value City LLC”) and Retail Ventures, Inc. (“Retail Ventures”) on September 3, 2008. Now before the Court are the Parties cross motions for summary judgment on the issue of whether Retail Ventures is liable to Saginaw Property for the unpaid rent.

The facts are not in dispute. Value City of Michigan, Inc. (“Value City of Michigan”) leased retail space from Saginaw Property's predecessor in 1997. Value City Department Stores, Inc. (“Value City Inc.”), Value City of Michigan's parent company, executed a guaranty in support of that lease. The guaranty provides that Value City Inc., “together with its successors and assigns, including, without limitation, any entity succeeding thereto by merger, consolidation or acquisition of its assets substantially as an entirety,” will meet the obligations of Value City of Michigan in the event of a default. [Dkt. # 18-A at 1]. In 2003, Value City Inc. reorganized; first creating Retail Ventures, then merging with a subsidiary of Retail Ventures so that Value City Inc. survived as a wholly owned subsidiary of Retail Ventures. Value City Inc. later merged with and into Defendant Value City LLC, and Value City Inc. subsequently dissolved.

The crux of this dispute is whether Retail Ventures is a “successor” of Value City Inc. under the lease guaranty. It is undisputed that Value City LLC is a successor to Value City Inc. and liable pursuant to the guaranty, but this Court stayed the case against Value City LLC on January 27, 2009

Not Reported in F.Supp.2d, 2009 WL 3536616 (E.D.Mich.)
 (Cite as: 2009 WL 3536616 (E.D.Mich.))

[Dkt. # 16], pending resolution of Value City LLC's bankruptcy proceedings. *See* 11 U.S.C. § 362. Retail Ventures has not sought bankruptcy protection.

This case presents a unique legal question, even though the issue arises from a fairly common corporate transaction. The Defendants used a vehicle known as a reverse triangular merger, common in acquisitions, for a corporate restructuring. If the transaction occurred as part of an acquisition, Retail Ventures would not be a “successor” to Value City Inc., as that term is commonly understood, and therefore not liable on the guaranty. However, the parties have not cited a Michigan case discussing successor liability in the context of a similar corporate restructuring, nor has the Court's search revealed any such authority, meaning the Court is presented with an issue of first impression under Michigan Law.^{FN1}

^{FN1} Retail Ventures cites *Cima v. Wellpoint Health Networks, Inc.*, No. 05-4127, 2008 U.S. Dist. LEXIS 84882 (S.D.Ill. Oct. 22, 2008), and contends the transaction at issue in *Cima* was “nearly identical” to the transaction in this case. [Dkt. # 19 at 14]. It is identical to the extent that the *Cima* court held that an acquiring corporation in a reverse triangular merger is not liable as the successor to the target, but like most cases that discuss this type of merger, the acquiring corporation was unrelated to the target before the transaction. This case is unique because it is a restructuring transaction not an acquisition. The acquiring corporation was actually created by the target in order to restructure the company.

The difference between an acquisition and a corporate restructuring does not present a justification for departing from settled law. Furthermore, plaintiff Saginaw Property has not presented a detailed factual record concerning the initial restructuring, nor alleged that it was fraudulent or otherwise improper. Consequently, Retail Ventures' motion for summary judgment will be **GRANTED**,

Saginaw Property's motion will be **DENIED**, and all Plaintiff's claims against Retail Ventures will be **DISMISSED WITH PREJUDICE**.

I

*2 On August 13, 1997, MRSLV Saginaw, LLC (“MRSLV”), as landlord, and Value City of Michigan, as tenant, entered into a twenty-year lease for a commercial property in Saginaw, Michigan. The lease established an annual rent of \$823,472.00, to be paid in monthly installments of \$68,622.67.

Contemporaneous to the execution of the lease agreement, Value City Inc. and MRSLV executed a guaranty of the lease agreement. [Dkt. # 12-3]. Value City Inc. became the guarantor, “together with its successors and assigns, including, without limitation, any entity succeeding thereto by merger, consolidation or acquisition of its assets substantially as an entirety ...” [Dkt. # 18-A]. As the guarantor, Value City Inc. “unconditionally and irrevocably guarantee[d]” that tenant Value City of Michigan would complete the duties created by the lease. *Id.* The guaranty is unaffected by “the voluntary or involuntary liquidation, dissolution, sale of all or substantially all of the assets ... bankruptcy ... [or] reorganization ...” *Id.* ¶ 2(g). Likewise, a sale by MRSLV of the leased premises did not alter the guaranty. *Id.* ¶ 2(n). The guaranty was binding on the successors and assigns of MRSLV and Value City Inc. *Id.* ¶ 16.

On September 21, 2005, Saginaw Property acquired the shopping center owned by MRSLV, including the leased premises. In April of 2008, Value City of Michigan vacated the property and ceased paying monthly rent. Saginaw Property filed suit against Defendants alleging that both are “successors” under the guaranty and liable for unpaid rent. It is undisputed that Value City LLC is the successor to Value City Inc., and therefore a “guarantor” under the lease. The principal question is whether Retail Ventures is also a successor and guarantor.

Not Reported in F.Supp.2d, 2009 WL 3536616 (E.D.Mich.)
 (Cite as: 2009 WL 3536616 (E.D.Mich.))

Plaintiff acknowledges that Value City Inc. did not merge directly with Retail Ventures. Rather, Plaintiff characterizes Retail Ventures as the successor to Value City Inc. because of a triangular merger that combined Value City Inc. with a wholly owned subsidiary of Retail Ventures. By contrast, Retail Ventures labels its relationship as a shareholder of Value City Inc., and later, a holder of membership interests in Value City Inc.'s successor, Value City LLC.

The structure of the related entities has changed substantially since the lease and guaranty were signed in 1997. At that time, Value City Inc. owned Value City of Michigan, other Value City subsidi-

aries, Filene's Basement, and DSW Shoes. Graphics adopted from Retail Ventures' renewed motion for summary judgment [Dkt. # 19] are useful to understanding the series of transactions that led to the current structure. The graphics refer to Retail Ventures as "RVI," Value City Inc. as "VCDS, Inc.," and Value City LLC as "VCDS LLC." The first graphic depicts the structure of the related entities at the time the lease agreement and guaranty were signed in 1997.

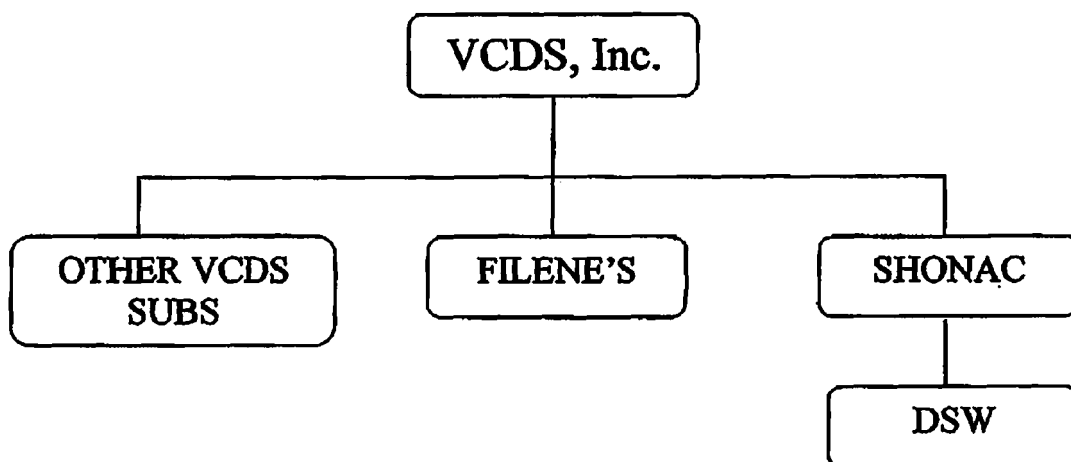

*3 Value City Inc. completed the first phase of its reorganization in 2003. First, it formed Retail Ventures as a wholly-owned affiliate that would become a holding company.

Not Reported in F.Supp.2d, 2009 WL 3536616 (E.D.Mich.)
 (Cite as: 2009 WL 3536616 (E.D.Mich.))

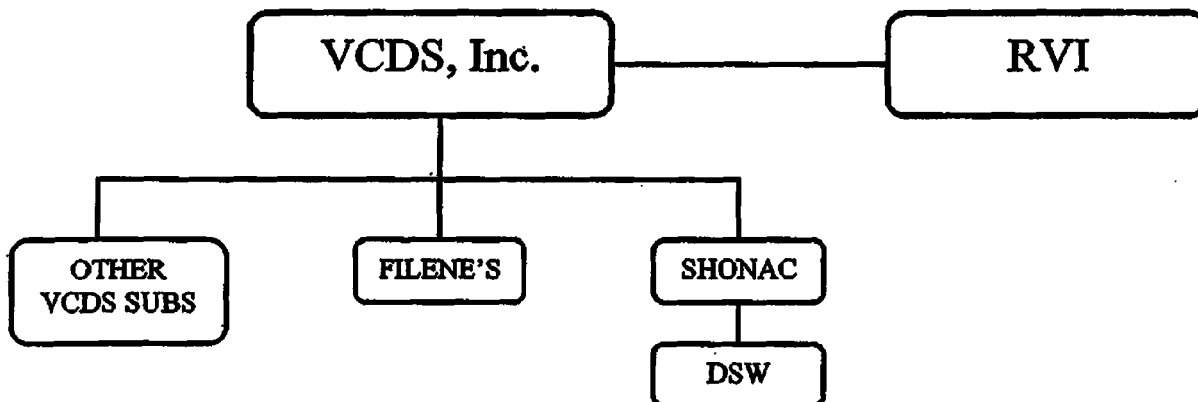

Next, Retail Ventures formed several wholly owned subsidiary affiliates, including one called "Merger Sub Inc."

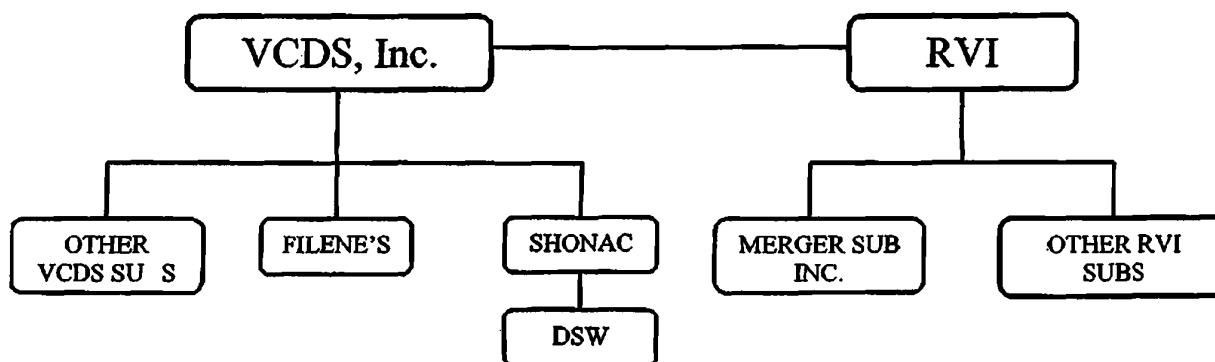

Next, Merger Sub Inc. merged with and into Value City Inc. with Value City Inc. as the surviving corporation.

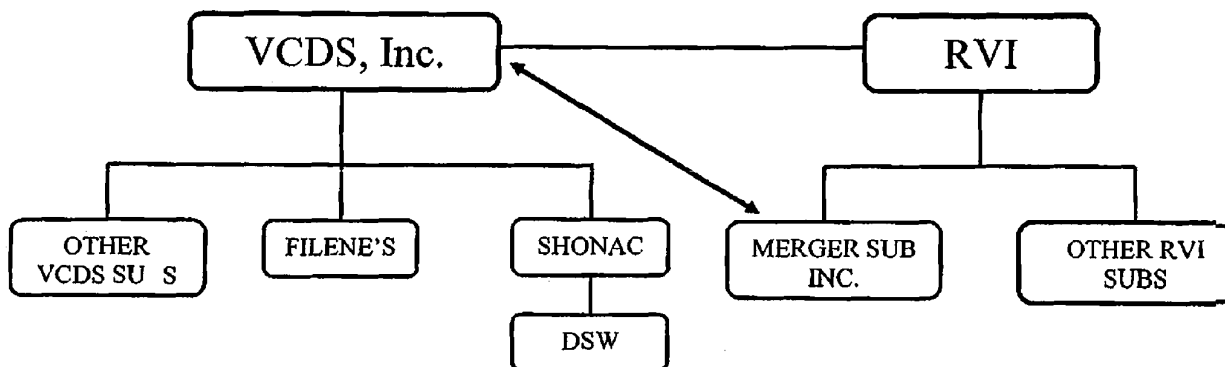

Value City Inc. became a wholly owned subsidiary of Retail Ventures.

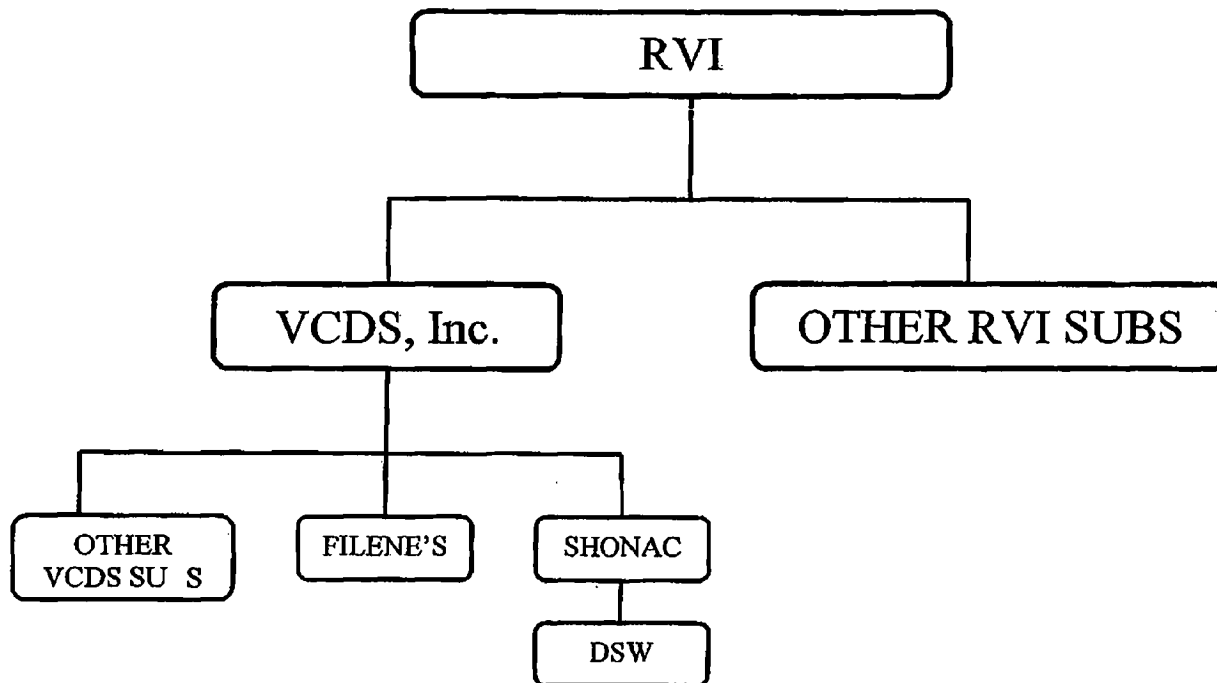

Retail Ventures explained the restructuring and the related shareholder transactions in its renewed motion for summary judgment:

Through the merger between [Value City Inc.] and Merger Sub Inc., (1) [Retail Ventures] received newly issued common shares of [Value City Inc.] in exchange for all of the common shares of Merger Sub held by [Retail Ventures], (2) all of [Retail Ventures'] common shares (which were owned by [Value City Inc.]) were cancelled and (3) the outstanding common shares of [Value City Inc.] (i.e. the public shares) were converted into and exchanged for common shares of [Retail Ventures].

Renewed Mot. for Summ. J. Ex. B at 5; [Dkt. # 19]. Such transactions are known as triangular mergers, whereby the acquiring company, Retail Ventures, forms a wholly-owned subsidiary that merges with the target, Value City Inc., and the outstanding shares of the target are exchanged for shares of the acquiring company or some other consideration. This transaction is a reverse triangular merger because the target, Value City Inc., survived as a separate entity with its assets and liabilities intact, and

distinct from its new shareholder-owner, Retail Ventures.

Retail Ventures explained the transaction in a form 8k filed with the Securities and Exchange Commission on October 8, 2003:

Effective October 8, 2003, [Value City Inc.] reorganized [its] corporate structure into a “holding company” structure, consisting of a holding company conducting all of the business previously conducted by [Value City Inc.] through [Value City Inc.] and other wholly-owned direct and indirect operating subsidiaries. The name of the new holding company is [Retail Ventures] and as with [Value City Inc.], it is an Ohio corporation. As described below, in connection with reorganization, holders of common stock of [Value City Inc.] became holders of an identical number of shares of common stock of [Retail Ventures], and [Value City Inc.] became a wholly-owned subsidiary of [Retail Ventures].

In the merger, [Value City Inc.] merged with Value City Merger Sub, Inc., a newly-formed, wholly owned direct subsidiary of [Retail Ven-

tures] (the “Merger”), with [Value City Inc.] as the surviving corporation of the Merger. In the Merger, each outstanding share of common stock of [Value City Inc.] and each share of common stock of [Value City Inc.] held in treasury was automatically converted into one share of common stock of [Retail Ventures]. Each share of Value City Merger Sub, Inc. common stock was converted into a share of [Value City Inc.] common stock. Additionally, each outstanding option to purchase shares of [Value City Inc.] common stock was automatically converted into an option to purchase, upon the same terms and conditions, an identical number of shares of [Retail Ventures] common stock, and the stock options were assumed by and continued as stock options of [Retail Ventures]. In addition, Retail Ventures assumed sponsorship of all employee benefits pursuant to the terms of the Merger. [Value City Inc.] will continue to operate as a wholly owned subsidiary of [Retail Ventures] under the name “Value City Department Stores, Inc.”

*4 As a result of the reorganization, all the business and operations previously conducted by [Value City Inc.] and its subsidiaries are now conducted by [Retail Ventures] and its subsidiaries, and the assets and liabilities of [Retail Ventures] and its subsidiaries on a consolidated basis are the same as the assets and liabilities of [Value City Inc.] and its subsidiaries immediately before the reorganization. The capital stock of [Retail Ventures] has the same designations, rights, and preferences as the capital stock of [Value City Inc.] prior to the reorganization. In addition, the persons who were directors and executive officers of [Value City Inc.] prior to the reorganization are directors and executive officers of [Retail Ventures] after the reorganization.

[Dkt. # 18-E at 2].

On October 7, 2003, Retail Ventures issued a press release entitled “[Value City Inc.] Is Now [Retail Ventures].” [Dkt. # 19-C]. The press release provides the following summary of the reorganiza-

tion:

[Value City Inc.] today announced the adoption of a new holding company structure for its operating units and stand-alone service organization. As a result, the stock of [Value City Inc.] will be exchanged on a share-for-share basis for shares of the new holding company, [Retail Ventures], and [Value City Inc.] will become a wholly owned subsidiary of [Retail Ventures].

[Dkt. # 19-C].

A Retail Ventures executive, James McGrady, described the restructuring as follows:

[Value City Inc.] caused [Retail Ventures] to be incorporated as a direct, wholly-owned subsidiary of [Value City Inc.]. [Retail Ventures] then caused certain subsidiaries, including Merger Sub, to be incorporated as wholly-owned subsidiaries of [Retail Ventures]. Merger Sub, not [Retail Ventures], was then merged with and into [Value City Inc.]. Through the merger between [Value City Inc.] and Merger Sub, (1) [Retail Ventures] received newly-issued common shares of [Value City Inc.] in exchange for all of the common shares of Merger Sub held by [Retail Ventures], (2) all of [Retail Ventures'] common shares (which were owned by [Value City Inc.]) were cancelled and (3) the outstanding common shares of [Value City Inc.] (i.e., the public shares) were converted into and exchanged for common shares of [Retail Ventures].

Following the reorganization of the corporate structure ... [Value City Inc.] remained a separate and distinct corporate entity and continued to maintain its own assets and liabilities. [Retail Ventures] held 100% of the investment of [Value City Inc.].

[Dkt. # 13-3 at 2-3].

In December 2004, Retail Ventures and Value City Inc. further reorganized. First, Retail Ventures created Value City LLC as a wholly-owned subsidi-

Not Reported in F.Supp.2d, 2009 WL 3536616 (E.D.Mich.)
 (Cite as: 2009 WL 3536616 (E.D.Mich.))

ary, and then merged Value City Inc. into Value City LLC and dissolved Value City Inc. Value City LLC then distributed all of its stock in Filene's Basement and DSW to Retail Ventures in exchange for a \$240 million promissory note, dated January 1, 2005. [Dkt. # 19-E]. The promissory note was signed by the same person on behalf of both companies-James A. McGrady, who apparently served as both the executive vice president of Retail Ventures and the vice president of Value City LLC. The note was paid in full, including interest, by August 15, 2006. [Dkt. # 19-F]. Importantly, Saginaw Property has not alleged that the sale of Filene's and

DSW was fraudulent or otherwise unlawful. Nor has Saginaw Property argued that the proceeds of the sale were improperly distributed to the holders of equity interests in Value City LLC to the detriment of the company's creditors.

*5 The resulting structure is represented by the diagram below.

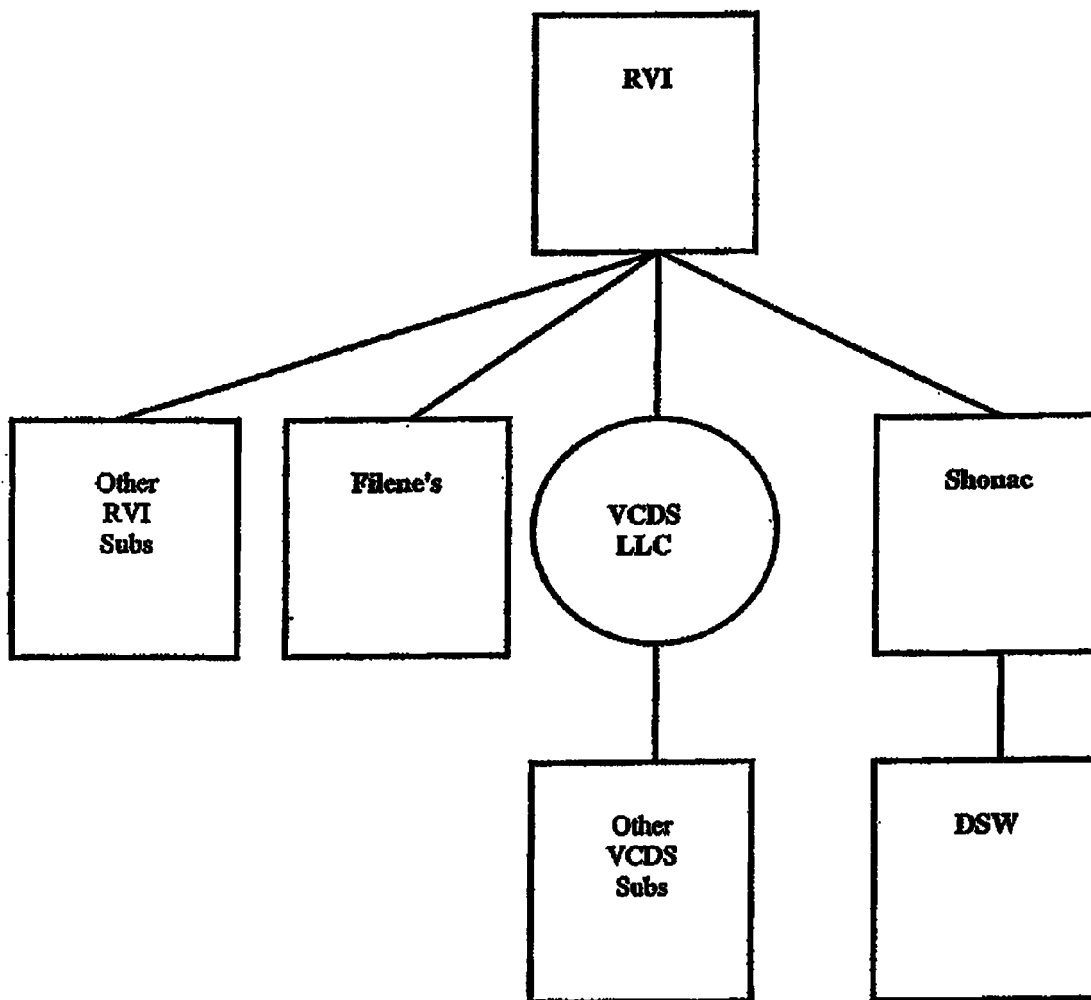

Finally, on January 23 2008, Retail Ventures

sold eighty-one percent of its interest in Value City

Not Reported in F.Supp.2d, 2009 WL 3536616 (E.D.Mich.)
 (Cite as: 2009 WL 3536616 (E.D.Mich.))

LLC to VCHI Acquisition Co., an entity owned by VCDS Acquisition Holdings, LLC, Emerald Capital Management, LLC, and Crystal Value, LLC. That transaction left Retail Ventures with a nineteen percent interest in its co-defendant, Value City LLC. Value City Inc. no longer existed, and any ownership stake Value City Inc. or Value City LLC had

held in DSW or Filene's had been sold to Retail Ventures. DSW and Filene's are not depicted in the diagram below.

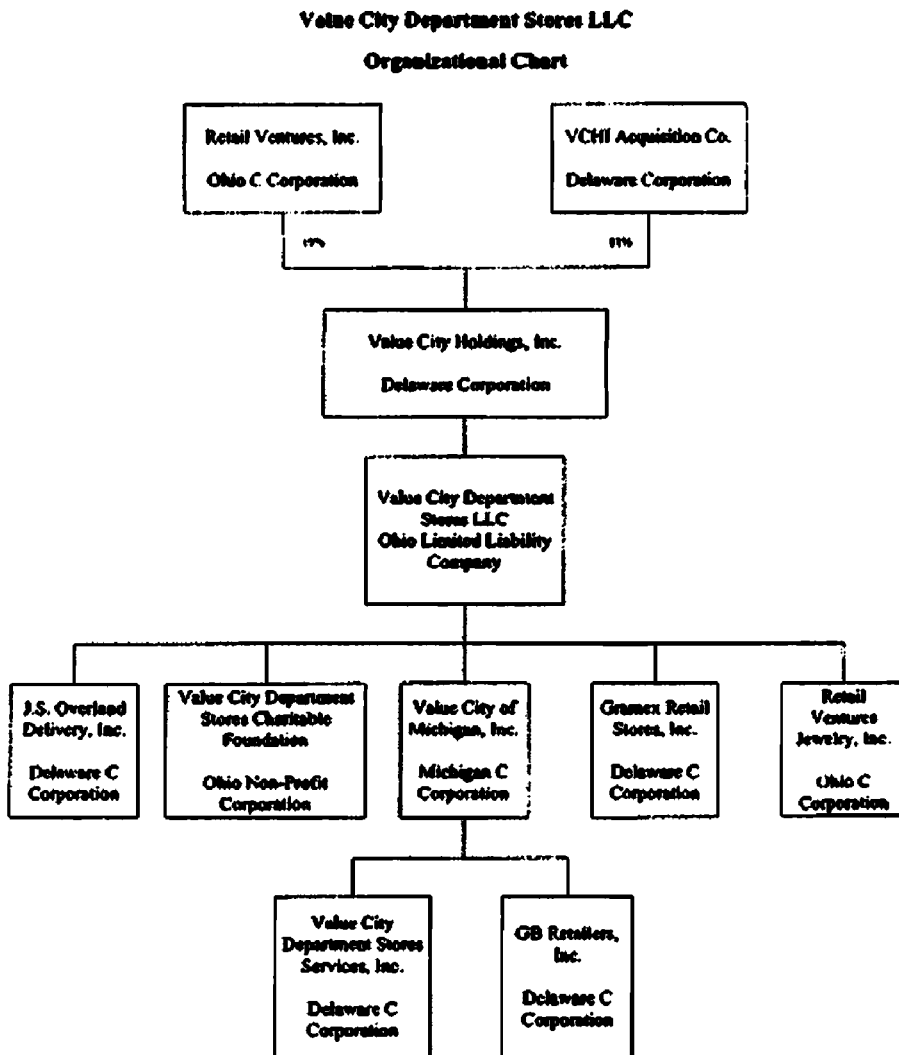

Retail Ventures' McGrady said of the series of transactions:

The October 8, 2003 reorganization of [Value City Inc.] was not a merger or consolidation between [Retail Ventures] and [Value City Inc.]. Furthermore, the 2003 reorganization of [Value

City Inc.] was a corporate restructuring and not an acquisition by [Retail Ventures] of the assets of [Value City Inc.] substantially as an entirety.

[Dkt. # 13-3 at 2-3]. Consequently, in its view, Retail Ventures is not liable under the 1997 lease guaranty because it is not the “successor” of Value

Not Reported in F.Supp.2d, 2009 WL 3536616 (E.D.Mich.)
(Cite as: 2009 WL 3536616 (E.D.Mich.))

City Inc within the meaning of the lease guaranty and Michigan law. Rather, it is simply the owner of nineteen percent of the membership interests in Value City LLC, Value City Inc.'s only real successor. [Dkt. # 19]. Saginaw Property, on the other hand, contends that no matter how the transactions are formally characterized, the company that was Value City Inc. "is now" Retail Ventures, consequently Retail Ventures must be Value City Inc.'s successor and liable under the guaranty. [Dkt. # 18].

On September 3, 2008, Saginaw Property filed the instant complaint. On October 26, 2008, Value City LLC petitioned for Chapter 11 bankruptcy protection in the Southern District of New York. Retail Ventures did not file for protection. On January 27, 2009 this Court stayed the proceedings against Value City LLC, but held that the proceedings could not be stayed as to Retail Ventures because Retail Ventures had not filed for Chapter 11 protection. [Dkt. # 16]. The parties then filed cross-motions for summary judgment [Dkt. # 18 & 19] on the issue of whether Retail Ventures is liable to Saginaw Property under the 1997 guaranty.

II

A motion for summary judgment is governed by [Federal Rule of Civil Procedure 56](#). The motion should be granted if "the pleadings, the discovery and disclosure materials on file, and any affidavits show that there is no genuine issue as to any material fact and that the movant is entitled to judgment as a matter of law." [Fed. R. Civ. Pro. 56\(c\)](#). When the "record taken as a whole could not lead a rational trier of fact to find for the nonmoving party," there is no genuine issue of material fact. [Mich. Paytel Joint Venture v. City of Detroit](#), 287 F.3d 527, 534 (6th Cir.2002).

The party seeking summary judgment has the initial burden of informing the Court of the basis for its motion, and identifying where to look in the record for relevant facts, "which it believes demonstrate the absence of a genuine issue of material fact." [Crelotex Corp. v. Catrett](#), 477 U.S. 317, 323,

106 S.Ct. 2548, 91 L.Ed.2d 265 (1986). The burden then shifts to the opposing party who must "set out specific facts showing a genuine issue for trial." [Fed. R. Civ. Pro. 56\(e\) \(2\)](#); [Anderson v. Liberty Lobby, Inc.](#), 477 U.S. 242, 250, 106 S.Ct. 2505, 91 L.Ed.2d 202 (1986). If the opposing party fails to raise genuine issues of fact and the record indicates the moving party is entitled to judgment as a matter of law, the court shall grant summary judgment. [Anderson](#), 477 U.S. at 250. The Court must view the evidence and draw all reasonable inferences in favor of the non-moving party and determine "whether the evidence presents a sufficient disagreement to require submission to a jury or whether it is so one-sided that one party must prevail as a matter of law." [Anderson v. Liberty Lobby, Inc.](#), 477 U.S. 242, 251-52, 106 S.Ct. 2505, 91 L.Ed.2d 202 (1986).

*6 The party opposing the motion may not "rely on the hope that the trier of fact will disbelieve the movant's denial of a disputed fact," but must make an affirmative showing with proper evidence in order to defeat the motion. [Street v. J.C. Bradford & Co.](#), 886 F.2d 1472, 1479 (6th Cir.1989). A party opposing a motion for summary judgment must designate specific facts in affidavits, depositions, or other factual material showing "evidence on which the jury could reasonably find for the plaintiff." [Anderson](#), 477 U.S. at 252. "[T]he party opposing the summary judgment motion must 'do more than simply show that there is some "metaphysical doubt as to the material facts." ' " [Highland Capital, Inc. v. Franklin Nat. Bank](#), 350 F.3d 558, 564 (6th Cir.2003) (citing [Pierce v. Commonwealth Life Ins. Co.](#), 40 F.3d 796, 800 (6th Cir.1994) (quoting [Matsushita Elec. Indus. Co. v. Zenith Radio Corp.](#), 475 U.S. 574, 586, 106 S.Ct. 1348, 89 L.Ed.2d 538 (1986))).

III

The question framed by the parties cross motions is whether Retail Ventures is a successor to Value City Inc. within the meaning of the 1997 guaranty. The guaranty provision provided that it

Not Reported in F.Supp.2d, 2009 WL 3536616 (E.D.Mich.)
 (Cite as: 2009 WL 3536616 (E.D.Mich.))

bound Value City Inc. “together with its successors and assigns, including, without limitation, any entity succeeding thereto by merger, consolidation or acquisition of its assets substantially as an entirety”

Value City Inc., Value City LLC, and Retail Ventures are or were organized under Ohio law, but the guaranty contains a choice of law clause, which provides that Michigan law should apply. [Dkt. # 12-A ¶ 5]. Because neither party raised the choice of law issue, and both implicitly rely on Michigan law, the Court will accept the parties' premise that the choice of law provision governs the successor liability provision of the guaranty and apply Michigan law.

Under Michigan law, the interpretation of a contract is a question of law. *Royal Ins. Co. of Am. v. Orient Overseas Container Line Ltd.*, 525 F.3d 409, 421 (6th Cir.2008) (citation and quotation omitted). “The question of whether the language of a written agreement is ambiguous is one of law; therefore, it may be resolved summarily.” *Parrett v. Am. Ship Bldg. Co.*, 990 F.2d 854, 858 (6th Cir.1993) (citations and quotation omitted). “Ambiguity exists if the language is susceptible to two or more reasonable interpretations.” *Royal*, 525 F.3d at 421 (citation and quotation omitted). When a contract is clear and unambiguous “there is no issue of fact to be determined.” *Id.*

Neither party contends there is any issue of fact that must be determined before interpreting the contract. Therefore, its meaning is a matter of law to be decided by the Court. The narrow issue is whether Retail Ventures is Value City's “successor.” That term that has a specific meaning under Michigan Law. The term was also defined in the guaranty, and includes “without limitation, any entity succeeding thereto by merger, consolidation or acquisition of Value City Inc.'s assets substantially as an entirety”

*7 Here, Saginaw Property advances three alternative theories to support its contention that the

2003 reorganization converted Retail Ventures into a successor of Value City Inc. Specifically, it contends that (A) Retail Ventures acquired all of Value City Inc.'s assets; (B) that Retail Ventures merged with Value City Inc.; and/or (C) that Retail Ventures “is” Value City Inc. Saginaw Property, however, does not cite any legal authority to advance its arguments. In fact, Saginaw Property's motion for summary judgment cites a single case as its legal authority. That case deals with contract interpretation under Michigan law, not successor liability.

A

Saginaw Property asserts that Retail Ventures became Value City Inc.'s successor through the acquisition of all or substantially all of Value City Inc.'s assets during the 2003 reorganization. As a general rule, when one company sells its assets to another the buyer is not the “successor” to the seller, and therefore not responsible for the seller's liabilities, unless the buyer assumed those liabilities or one of four narrow exceptions applies. *See* John R. Trentacosta, Michigan Contract Law § 16.17 (1998 & Supp.2008).

Saginaw Property's contends that the language of the guaranty demonstrates an assumption of liability by Retail Ventures because the guaranty expressly states that any company acquiring all or substantially all of Value City Inc.'s assets would become a successor within the terms of the guaranty. This argument fails because Retail Ventures never acquired any, much less substantially all, of Value City Inc.'s assets during the first phase of the reorganization. Value City Inc.'s public shareholders received common stock in Retail Ventures in exchange for their common stock in Value City Inc. Additionally, Value City Inc. issued new common stock to Retail Ventures in exchange for the common stock Retail Ventures held in Merger Sub. Stock is an asset of the person or entity who owns it and holds the certificate, but not of the corporation that issues it. *See Black's Law Dictionary* 112 (7th ed. 1999) (“Asset. 1. An Item that is owned and has

Not Reported in F.Supp.2d, 2009 WL 3536616 (E.D.Mich.)
 (Cite as: 2009 WL 3536616 (E.D.Mich.))

value. 2. (*pl.*) The entries on a balance sheet showing the items of property owned, including cash, inventory equipment, real estate, accounts receivable, and goodwill.”). Following the first phase of the reorganization, Value City Inc. retained all of the assets it held before the reorganization, including the real property it owned, the inventory in its stores, its leases, accounts, goodwill associated with its brand, and any ownership interests it held in its subsidiaries, like Value City of Michigan. The 2003 transaction was a reorganization in which the shares of Value City Inc. were exchanged on a one-for-one basis for shares of Retail Ventures, it was not a sale of substantially all of Value City Inc.’s assets to Retail Ventures.

Retail Ventures would eventually purchase some of Value City Inc.’s assets in the second phase of the reorganization, namely Value City Inc.’s ownerships interests in DSW and Filene’s, but that transaction was not completed until January 1, 2005. Moreover, there is no allegation that the price Retail Ventures paid for those assets was too low, or that the proceeds of the sale were distributed to Value City Inc.’s shareholders at the expense of its creditors.

*8 Even if the Court were to consider the series of transactions a sale of substantially all of Value City Inc.’s assets to Retail Ventures, the transactions still would not convert Retail Ventures into Value City Inc.’s successor because Retail Ventures was not a party to the lease guaranty. As a non-party, Retail Ventures is not bound by the guaranty’s terms and is only a successor if it would be recognized as a successor under Michigan law. *EEOC v. Waffle House, Inc.*, 534 U.S. 279, 294, 122 S.Ct. 754, 151 L.Ed.2d 755 (2002) (“It goes without saying that a contract cannot bind a non-party.”). The Michigan Supreme Court has held that successor liability will only arise in the context of an asset sale in five circumstances:

(1) where there is an express or implied assumption of liability; (2) where the transaction amounts to a consolidation or merger; (3) where

the transaction was fraudulent; (4) where some of the elements of a purchase in good faith were lacking, or where the transfer was without consideration and the creditors of the transferor were not provided for; or (5) where the transferee corporation was a mere continuation or reincarnation of the old corporation.

Craig v. Oakwood Hosp., 684 N. W.2d 296,314 (Mich.2004) (footnote omitted); *see also Johnson v. Ventra Group, Inc.*, 191 F.3d 732 (6th Cir.1999). Here, there was no express or implied assumption of liability. Moreover, Saginaw Property has not alleged that the transaction was fraudulent, or that the transaction lacked the elements of a purchase in good faith and did not provide for creditors. The only remaining issues, then, are whether the transaction was actually a merger or de facto merger, and whether Retail Ventures is liable as a “mere continuation or reincarnation” of Value City Inc. *Craig*, 684 N.W.2d at 314.

B

Retail Ventures never merged with Value City Inc., even though it did acquire all of Value City Inc.’s stock as the result of a merger. The transaction structure, used here to affect a corporate reorganization, is not uncommon. The reverse triangular merger is popular precisely because it allows the acquiring company, Retail Ventures, to gain control of the target, Value City Inc., without actually merging with the target or risking its own assets on the targets liabilities. *See, e.g., Kaufmann v. LVA Holdings, Inc.*, No. 05-cv-02140, 2006 U.S. Dist. LEXIS 49499 at *2 (D.Col. Oct. 22, 2008) (“The recognized purpose of this type of merger agreement is to avoid successor liability which would be the consequence of a direct merger of two constituent corporations. [It] is an artful but lawful dodge”). Value City Inc. remained separate and distinct from Retail Ventures throughout the 2003 reorganization. The fact that Value City Inc. actually created Retail Ventures and then merged with a subsidiary of its own newly created subsidiary does not alter the equation.

Not Reported in F.Supp.2d, 2009 WL 3536616 (E.D.Mich.)
 (Cite as: 2009 WL 3536616 (E.D.Mich.))

Nor did the transaction amount to a de facto merger. Under Michigan law, a de facto merger will lead to successor liability where each of four elements is met:

*9 (1) There is a continuation of the enterprise of the seller corporation, so that there is a continuity of management, personnel, physical location, assets, and general business operations.

(2) There is a continuity of shareholders which results from the purchasing corporation paying for the acquired assets with shares of its own stock, this stock ultimately coming to be held by the shareholders of the seller corporation so that they become a constituent part of the purchasing corporation.

(3) The seller corporation ceases its ordinary business operations, liquidates, and dissolves as soon as legally and practically possible.

(4) The purchasing corporation assumes those liabilities and obligations of the seller ordinarily necessary for the uninterrupted continuation of normal business operations of the seller corporation.

Craig, 684 N.W.2d at 314-15 (citing *Turner v. Bituminous Cas. Co.*, 397 Mich. 406, 244 N.W.2d 873, 879 (Mich.1976); see also *Chrysler Corp. v. Ford Motor Co.*, 972 F.Supp. 1097 (E.D.Mich.1997)). Here, even though the first two elements and potentially the fourth element were met, Value City Inc. never “ceased its ordinary business operations” or “liquidate[d] and dissolve[d].” In fact, Value City Inc. continued to operate Value City Department Stores as a wholly-owned subsidiary of Retail Ventures until Value City Inc. merged with Value City LLC. It is undisputed that Value City LLC is a successor to Value City Inc. Moreover, Value City Inc. retained all of its own assets following the merger with Merger Sub, such that Value City Inc.’s ability to meet its obligations to its creditors was unaffected by the reorganization.

C

Finally, Retail Ventures is not liable under the guaranty as a “mere continuation” of Value City Inc. The “mere continuation” or “continuity of enterprise” theories are similar to the de facto merger theory. *Trentacosta*, *supra* § 16.17; see also *Craig*, 684 N.W.2d at 315 (calling for analysis of the nature of the transaction to determine whether the buyer is the “mere continuation” of the seller). The continuity of enterprise theory, however, has only been applied in the context of products liability. *City Management Corp. v. U.S. Chemical Co.*, 43 F.3d 244, 251-53 (6th. Cir.1994) (interpreting Michigan law and holding continuity of enterprise theory is limited to products liability cases). Therefore, it does not apply to the lease guaranty at issue here.

IV

In this Court’s January 27, 2009 opinion, it emphasized that Saginaw property had not offered any evidence of a merger between Value City Inc. and Retail Ventures, and that absent a merger, Saginaw Property would have to prove that Retail Ventures stripped “significant assets for inadequate consideration” from Value City Inc. in order to prevail on the successor liability claim. *Saginaw Property, LLC v. Value City Dept. Stores, LLC*, No. 08-13782, 2009 WL 189963 (E.D.Mich. Jan.27, 2009). Saginaw Property has still not offered any evidence that there was a merger or consolidation between Retail Ventures and Value City Inc. Nor has it offered any proof that Retail Ventures received Value City Inc.’s assets for too little consideration or otherwise acted fraudulently in an attempt to avoid its obligations to Saginaw Property or its other creditors. Retail Ventures has met the burden of demonstrating an absence of genuine issues of material fact, and its entitlement to judgment as a matter of law. *Fed.R.Civ.P. 56*.

*10 Accordingly, it is **ORDERED** that Defendant Retail Ventures, Inc.’s motion for summary judgment is **GRANTED**.

It is further **ORDERED** that Plaintiff Saginaw

Not Reported in F.Supp.2d, 2009 WL 3536616 (E.D.Mich.)
(Cite as: **2009 WL 3536616 (E.D.Mich.)**)

Property, LLC's motion for summary judgment is
DENIED.

It is further **ORDERED** that Plaintiff Saginaw
Property, LLC's claims against Defendant Retail
Ventures, Inc. are **DISMISSED WITH PREJU-
DICE.**

E.D.Mich.,2009.

Saginaw Property, LLC v. Value City Dept. Stores,
LLC

Not Reported in F.Supp.2d, 2009 WL 3536616
(E.D.Mich.)

END OF DOCUMENT