



(12) **United States Patent**
Lesesky et al.

(10) **Patent No.:** **US 6,744,352 B2**
 (45) **Date of Patent:** ***Jun. 1, 2004**

(54) **SYSTEM, APPARATUS AND METHODS FOR DATA COMMUNICATION BETWEEN VEHICLE AND REMOTE DATA COMMUNICATION TERMINAL, BETWEEN PORTIONS OF VEHICLE AND OTHER PORTIONS OF VEHICLE, BETWEEN TWO OR MORE VEHICLES, AND BETWEEN VEHICLE AND COMMUNICATIONS NETWORK**

(75) Inventors: **Alan Lesesky**, Charlotte, NC (US); **Bob Weant**, Rock Hill, SC (US)

(73) Assignee: **Vehicle Enhancement Systems, Inc.**, Rock Hill, SC (US)

(*) Notice: Subject to any disclaimer, the term of this patent is extended or adjusted under 35 U.S.C. 154(b) by 0 days.

This patent is subject to a terminal disclaimer.

(21) Appl. No.: **10/051,772**

(22) Filed: **Jan. 17, 2002**

(65) **Prior Publication Data**

US 2003/0003777 A1 Jan. 2, 2003

Related U.S. Application Data

(63) Continuation-in-part of application No. 10/007,032, filed on Nov. 8, 2001, now Pat. No. 6,608,554, which is a continuation of application No. 09/569,995, filed on May 12, 2000, now Pat. No. 6,411,203, which is a continuation of application No. 08/907,861, filed on Aug. 8, 1997, now Pat. No. 6,064,299, which is a continuation-in-part of application No. 08/594,255, filed on Jan. 30, 1996, now Pat. No. 6,111,524, and a continuation-in-part of application No. 08/554,907, filed on Nov. 9, 1995, now abandoned.

(51) **Int. Cl.**⁷ **G08B 21/00**

(52) **U.S. Cl.** **340/431; 340/933**

(58) **Field of Search** **340/431, 435, 340/928, 933, 942, 944, 825.54, 825.69, 310.02; 307/9.1, 10.1; 280/441.1, 232**

(56) **References Cited**

U.S. PATENT DOCUMENTS

4,398,172 A 8/1983 Carroll et al. 340/942

(List continued on next page.)

FOREIGN PATENT DOCUMENTS

EP 0744322 A2 11/1996 16/2
 EP 0 802 082 A2 10/1997
 WO 93/22848 11/1993

(List continued on next page.)

OTHER PUBLICATIONS

“Materialflub per Infrarot”, Technische Rundschau, 1990.
 Translation of article entitled “Materialflub per Infrarot”, Technische Rundschau, 1990.
 Affidavit by Alan C. Lesesky.

Primary Examiner—Van Trieu

(74) *Attorney, Agent, or Firm*—Bracewell & Patterson, LLP

(57) **ABSTRACT**

A system, an apparatus, and methods are provided for data communications associated with a vehicle. The apparatus preferably includes at least one electronic subsystem associated with the vehicle and a plurality of electrical conductors connected to the at least one electronic subsystem and associated with the vehicle. A vehicle data communications protocol converter is preferably connected to the plurality of electrical conductors for converting a first data communications protocol associated with data communications along the plurality of electrical conductors to a second data communications protocol such as an infrared, an RF data, an Internet, or other network communications protocol. The apparatus also preferably includes a transceiver connected to the data communications protocol converter for transmitting the second data communications protocol from the vehicle and receiving the data communications protocol from another portion of the vehicle, a remote data communications terminal, another vehicle, or another communications network.

65 Claims, 33 Drawing Sheets

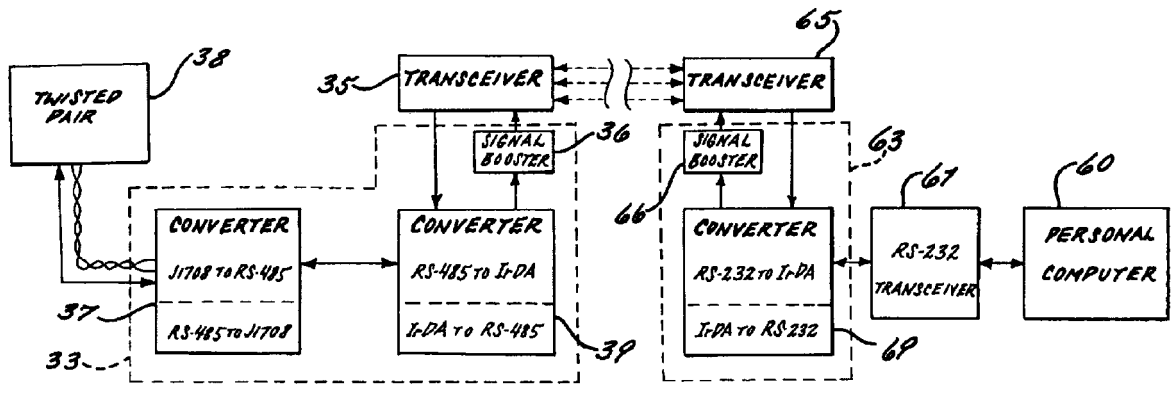

U.S. PATENT DOCUMENTS

4,506,386	A	3/1985	Ichikawa et al.	455/343
4,926,417	A	* 5/1990	Futami et al.	340/438
4,952,908	A	8/1990	Sanner	340/429
4,996,719	A	2/1991	Okazaki et al.	455/606
5,007,042	A	* 4/1991	Santi	340/310.02
5,025,253	A	6/1991	DiLullo et al.	340/825.54
5,081,667	A	1/1992	Drori et al.	379/59
5,385,476	A	1/1995	Jasper	439/38
5,442,810	A	8/1995	Jenquin	455/99
5,446,470	A	8/1995	Avignon et al.	343/713
5,488,352	A	1/1996	Jasper	340/431
5,503,421	A	* 4/1996	DeLisser et al.	280/441.1
5,570,087	A	10/1996	Lemelson	340/870.05
5,587,890	A	12/1996	Happ et al.	361/826
5,677,667	A	10/1997	Lesesky et al.	340/431
5,716,071	A	2/1998	Stanley et al.	280/407
5,732,074	A	3/1998	Spaur et al.	370/313
5,739,592	A	4/1998	Rigsby et al.	307/9.1
5,783,993	A	7/1998	Briski et al.	340/525
5,790,536	A	8/1998	Mahaney et al.	370/338
5,794,164	A	8/1998	Beckert et al.	701/1
5,798,577	A	8/1998	Lesesky et al.	307/10.7
5,802,545	A	9/1998	Coverdill	711/35
5,825,287	A	10/1998	Zarybnicky, Sr. et al. ..	340/453
5,852,405	A	12/1998	Yoneda et al.	340/825.02
D403,659	S	1/1999	Lesesky	D13/156

D404,170	S	1/1999	Lesesky	D26/124
5,884,202	A	3/1999	Arjomand	
5,900,803	A	5/1999	Politz et al.	340/825.54
5,917,632	A	6/1999	Lesesky	340/431
6,025,563	A	2/2000	Lesesky et al.	177/136
6,064,299	A	5/2000	Lesesky et al.	340/431
6,089,588	A	7/2000	Lesesky et al.	280/422
6,094,609	A	7/2000	Arjomand	
6,111,524	A	8/2000	Lesesky et al.	340/942
6,127,939	A	10/2000	Lesesky et al.	340/438
D434,006	S	11/2000	Lesesky et al.	D13/147
6,150,793	A	11/2000	Lesesky et al.	320/104
6,254,201	B1	7/2001	Lesesky et al.	303/122.02
6,352,137	B1	3/2002	Stegall et al.	188/1.11
6,378,959	B2	4/2002	Lesesky et al.	303/122.02
6,430,485	B1	8/2002	Hullinger	

FOREIGN PATENT DOCUMENTS

WO	97/17232	5/1997	16/2
WO	97/28988	8/1997	16/2
WO	98/34812	8/1998	7/70
WO	98/37432	8/1998		
WO	99/06987	2/1999		
WO	99/21383	4/1999	7/30
WO	99/35009	7/1999	16/2

* cited by examiner

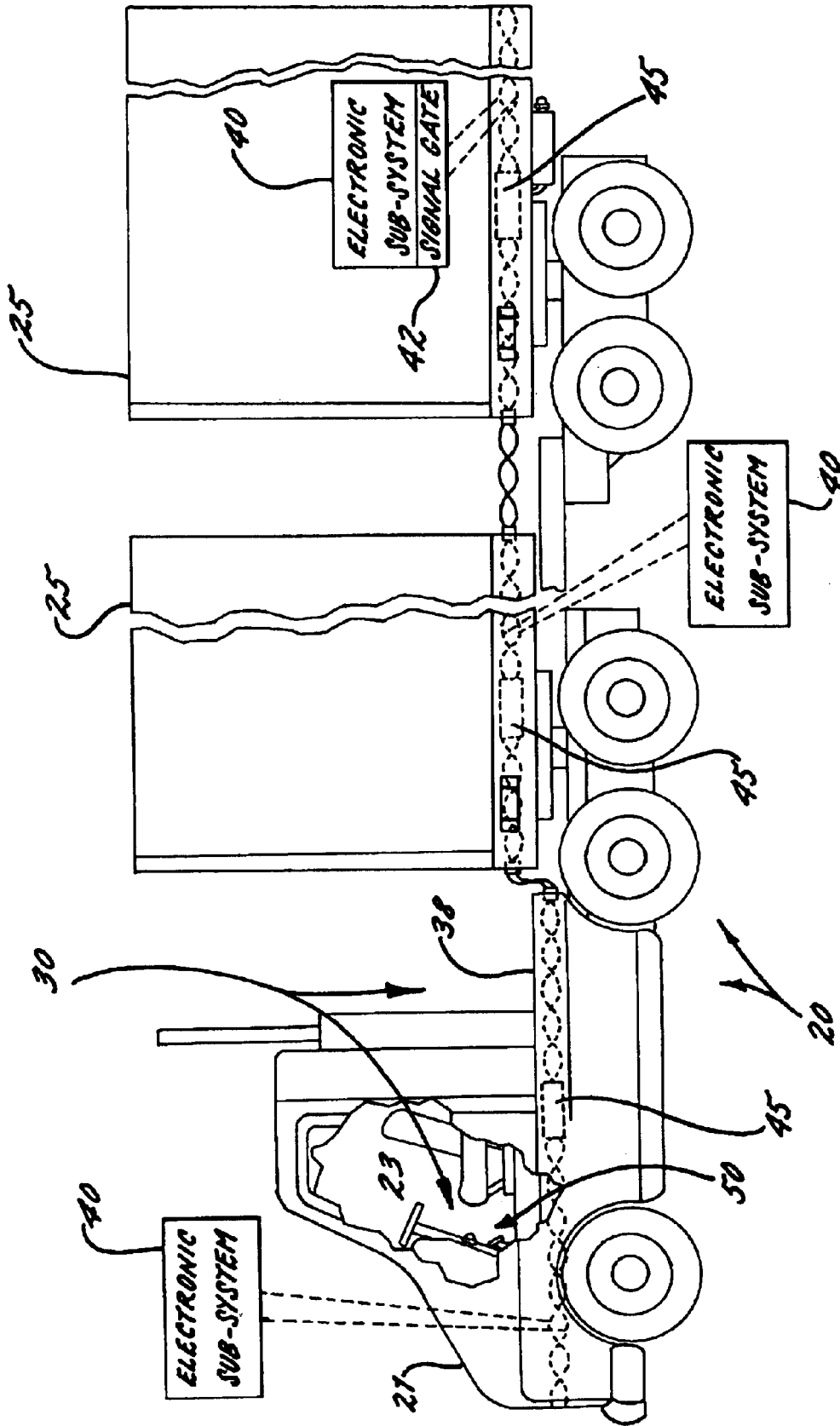

FIG. 1.

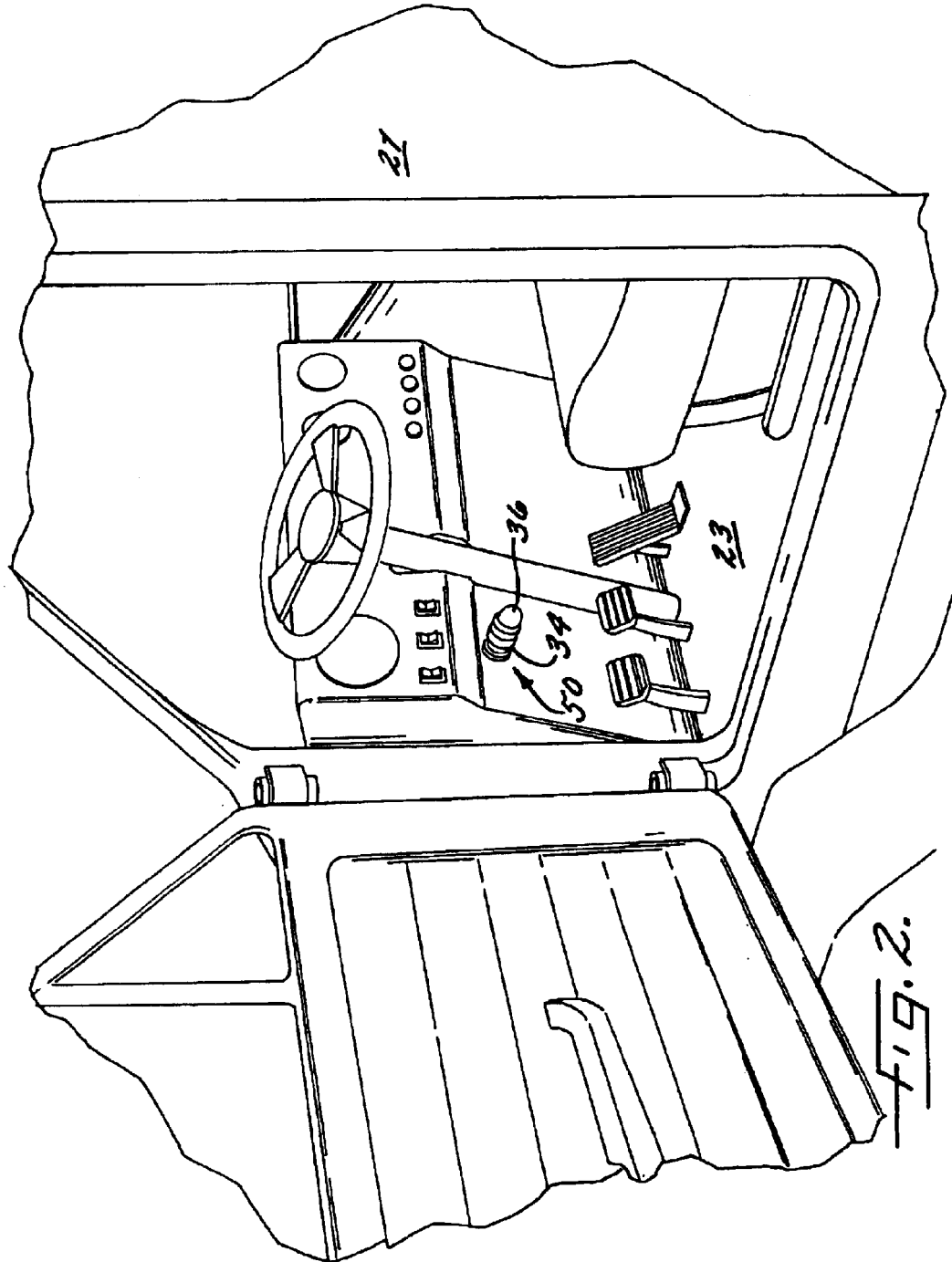
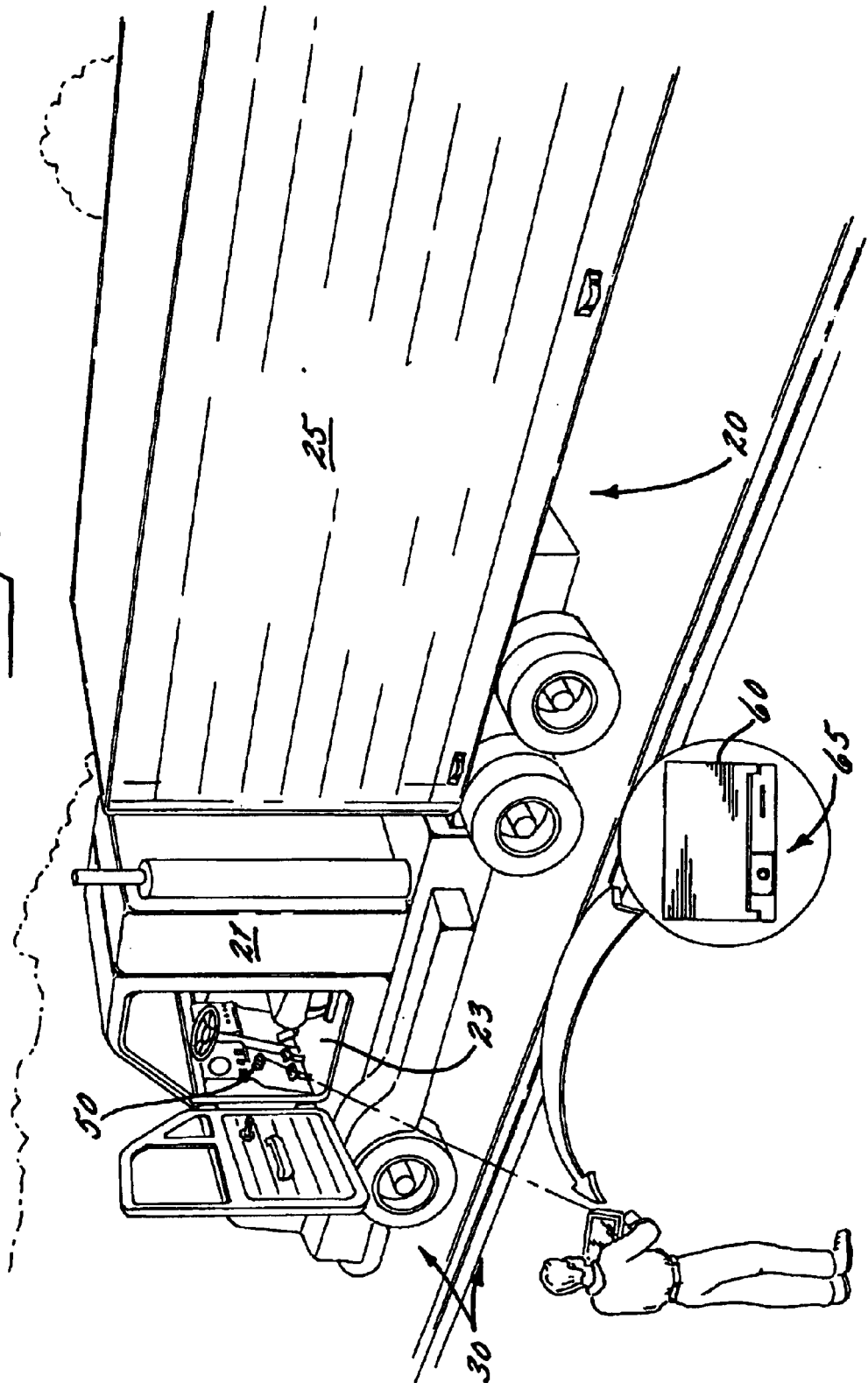
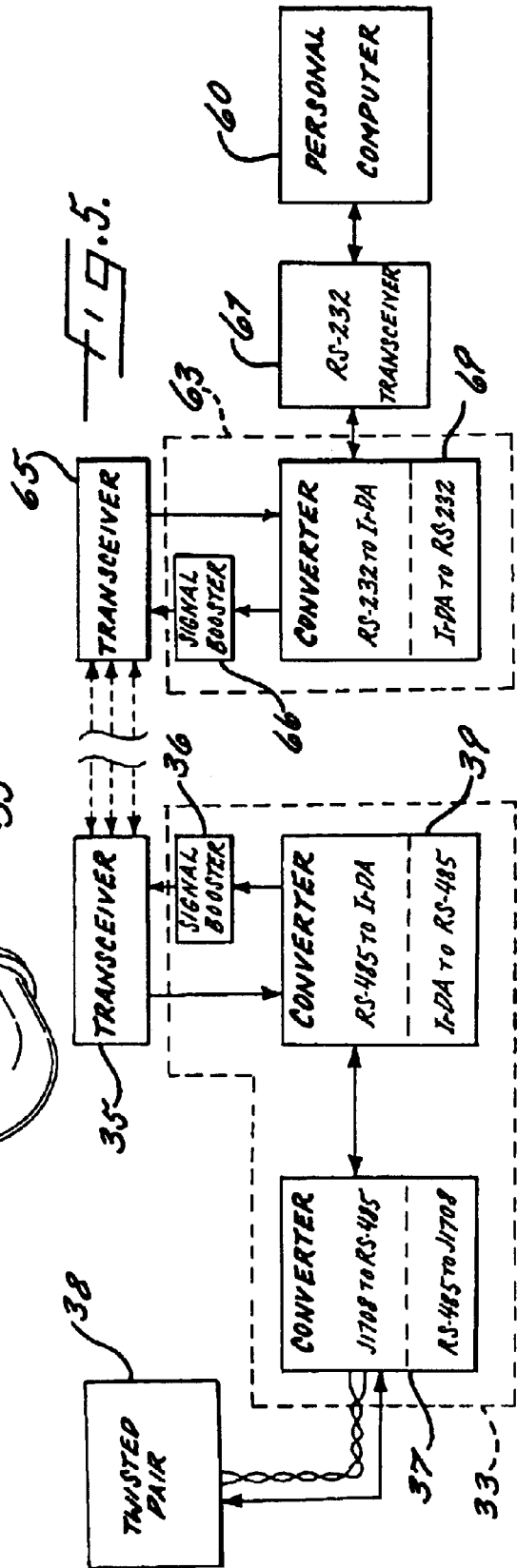
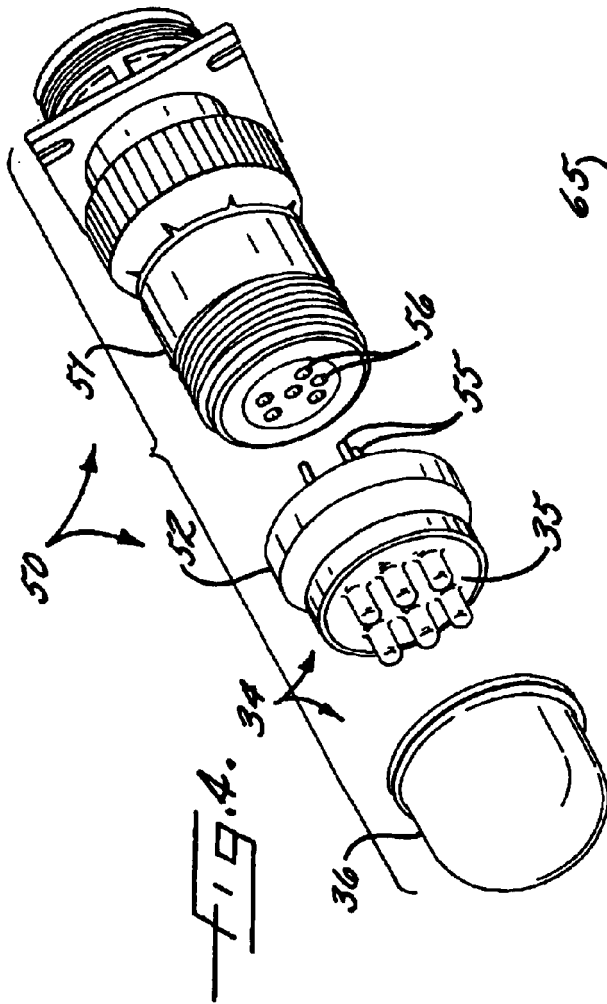
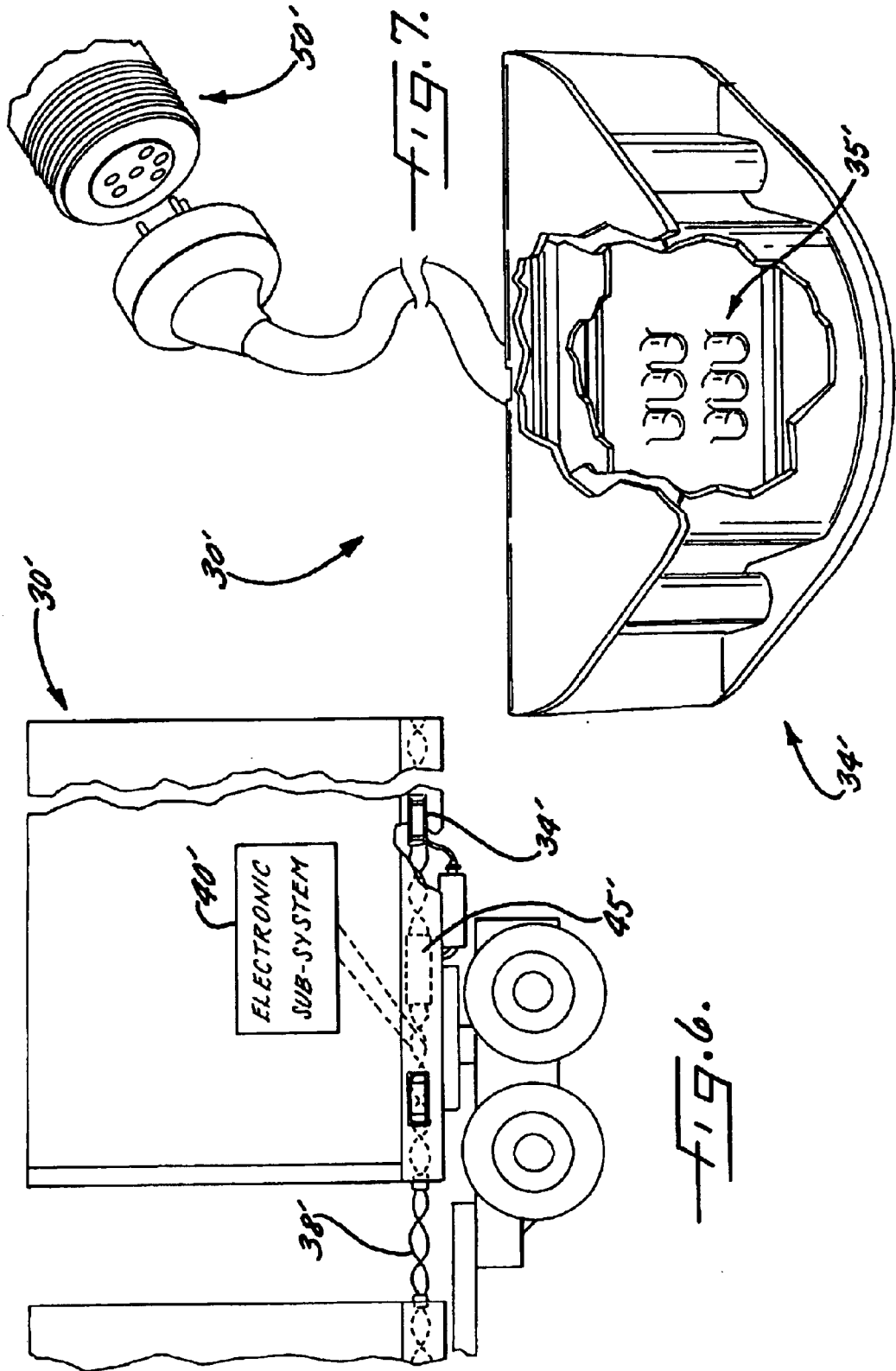
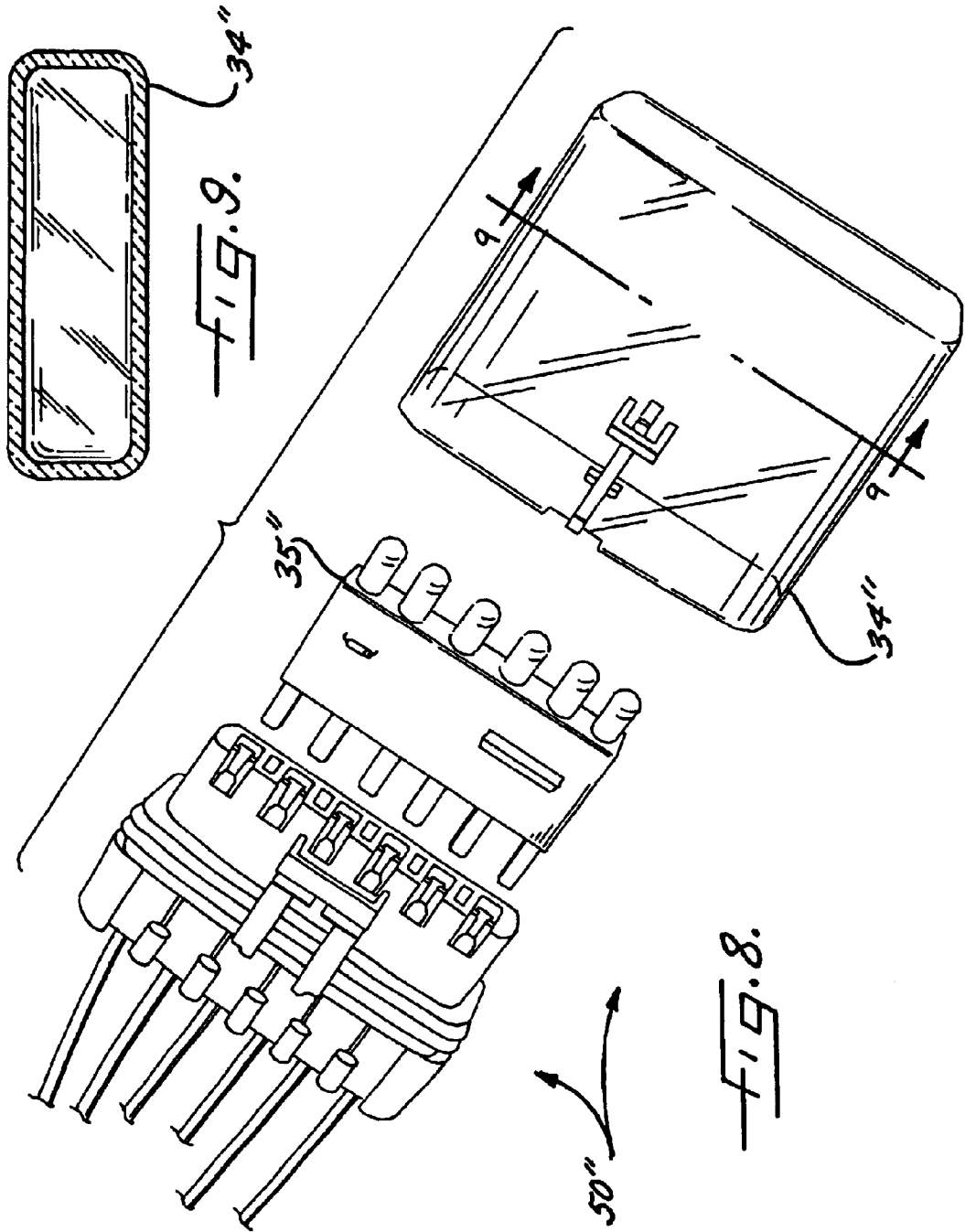

FIG. 3.









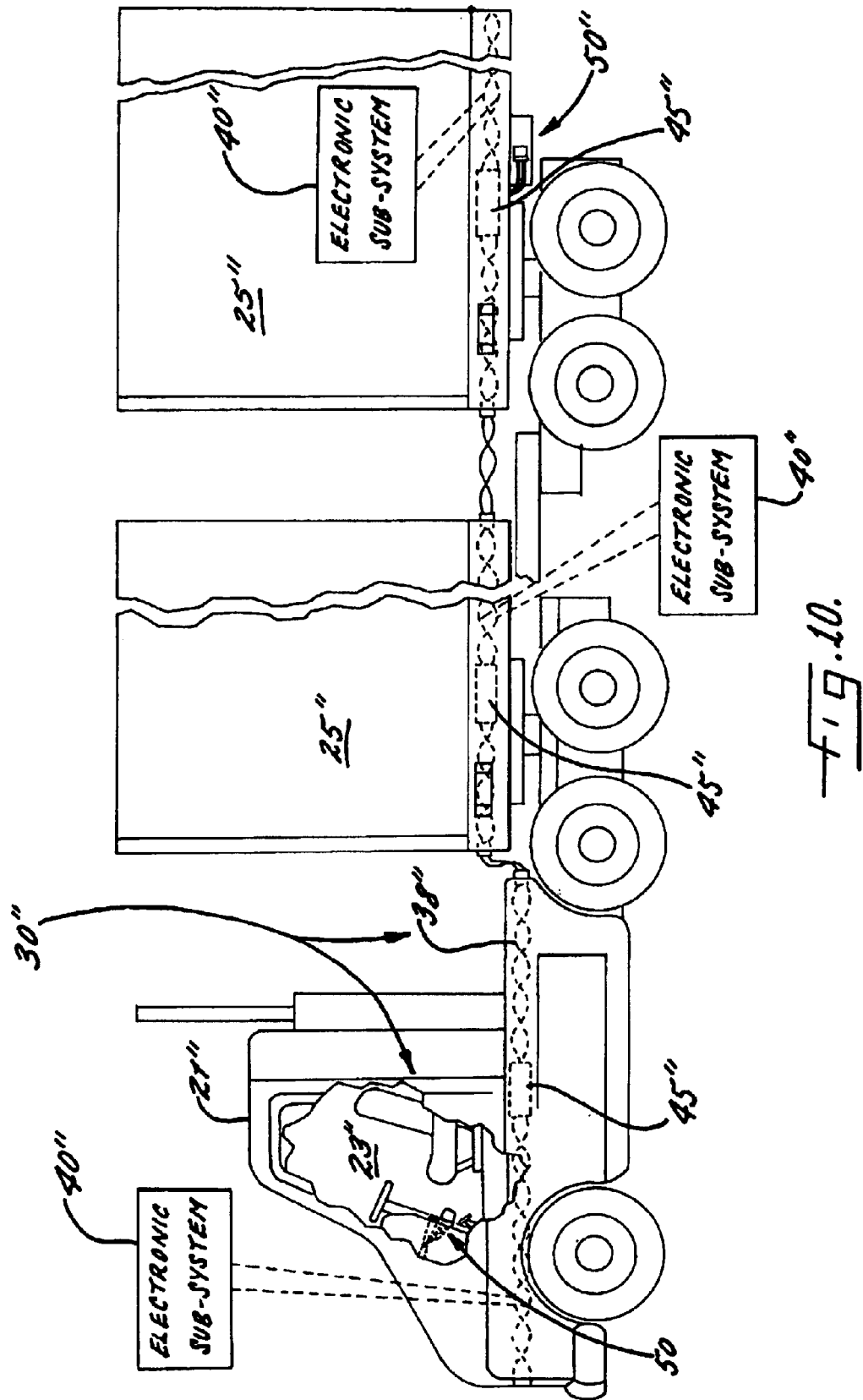

FIG. 10.

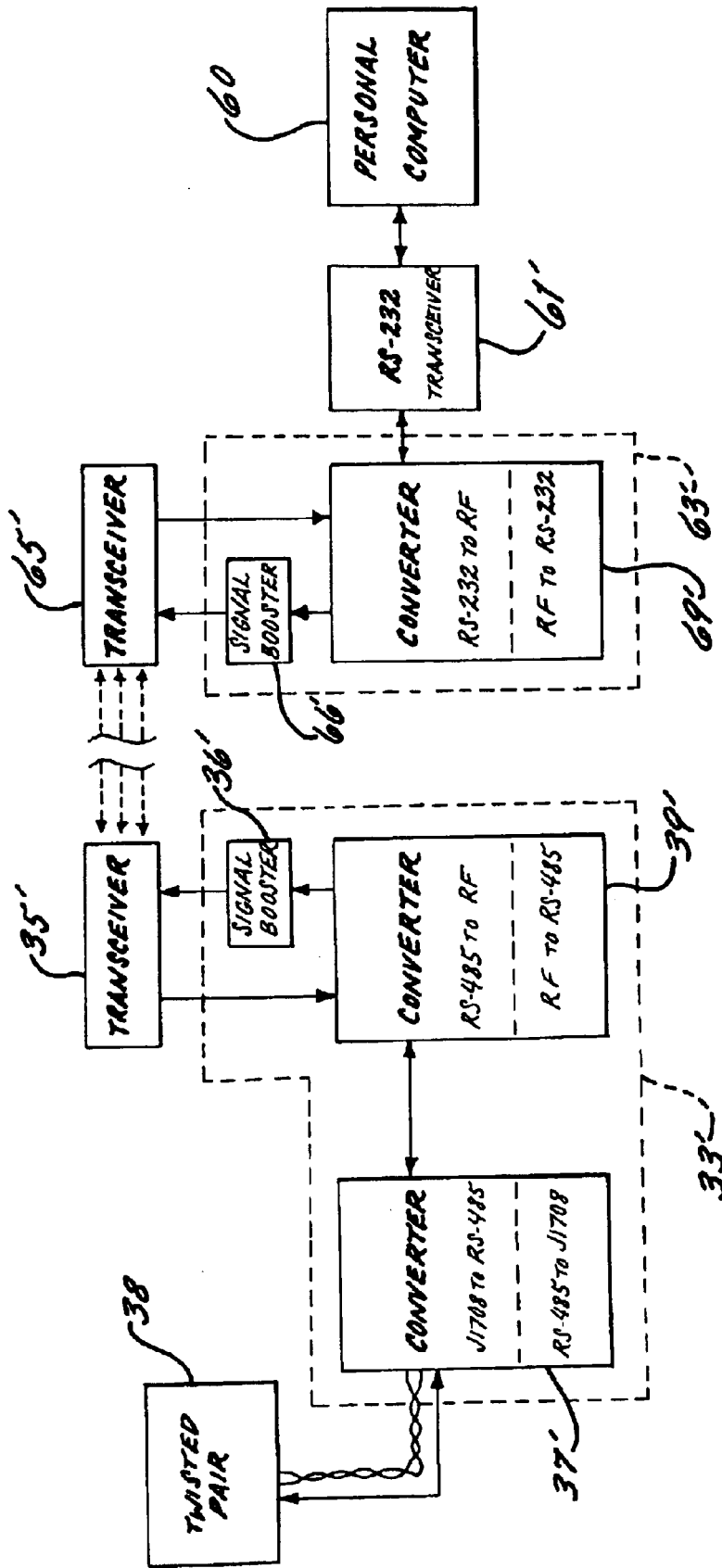
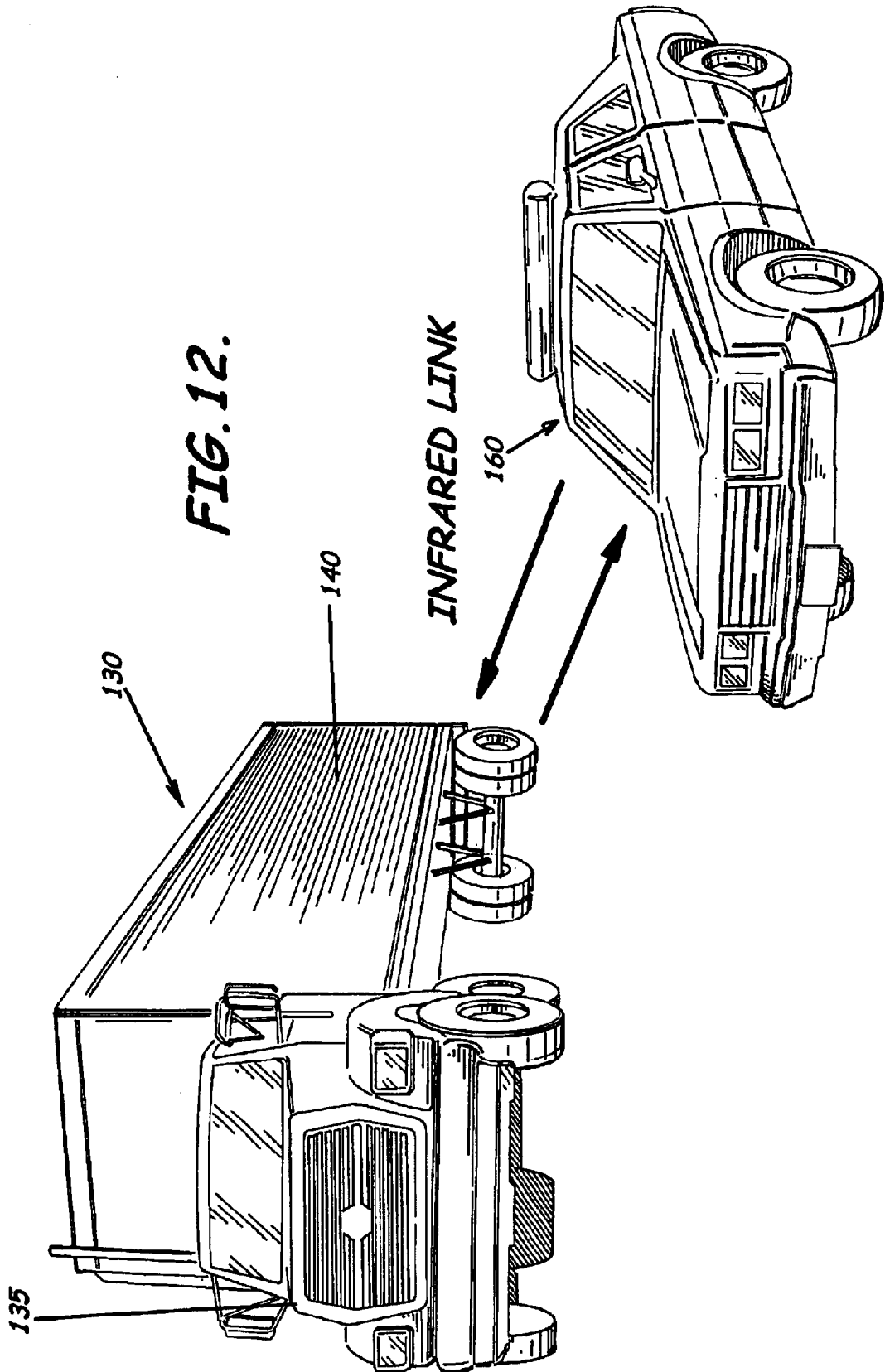

FIG. 11.



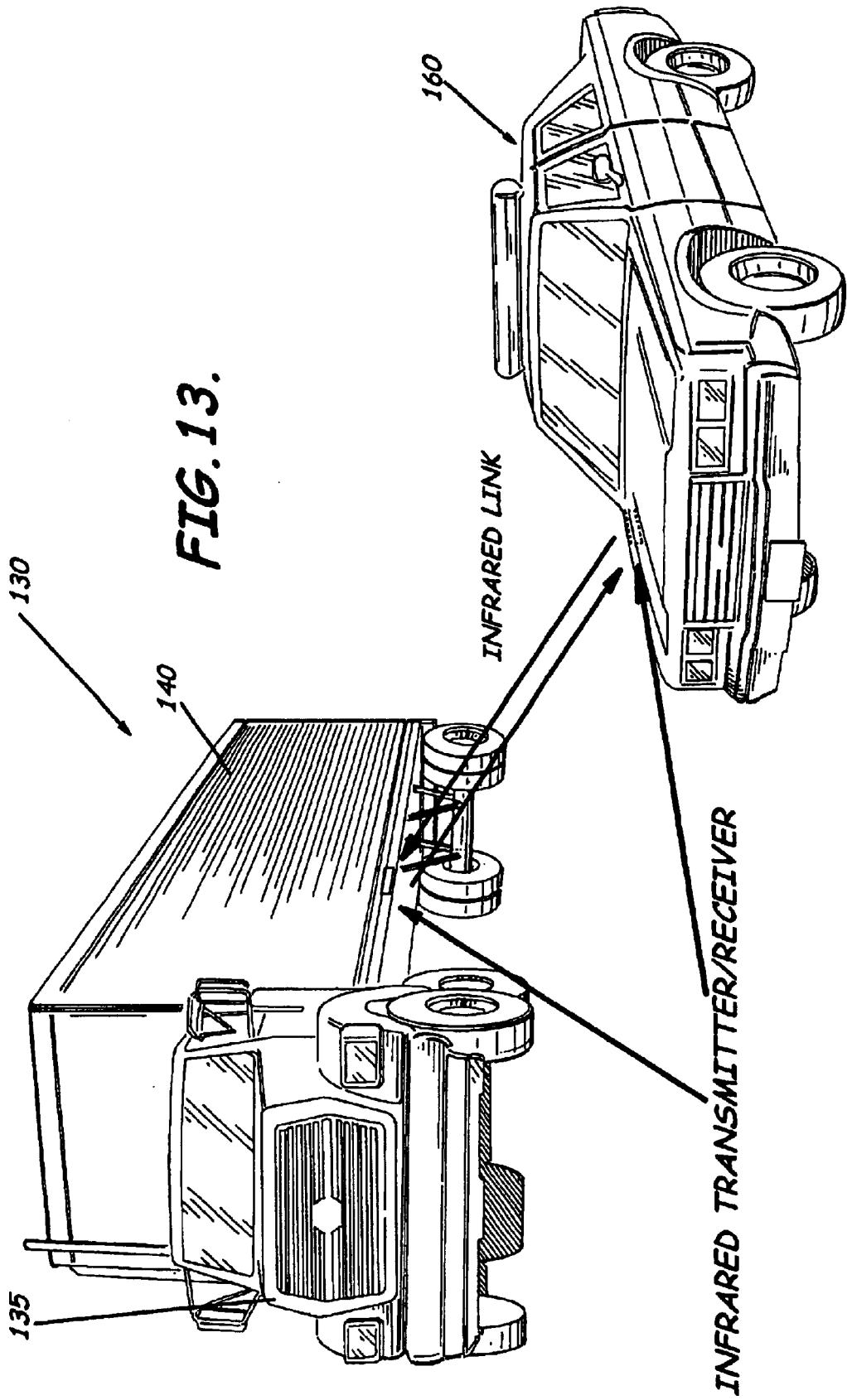

FIG. 14.

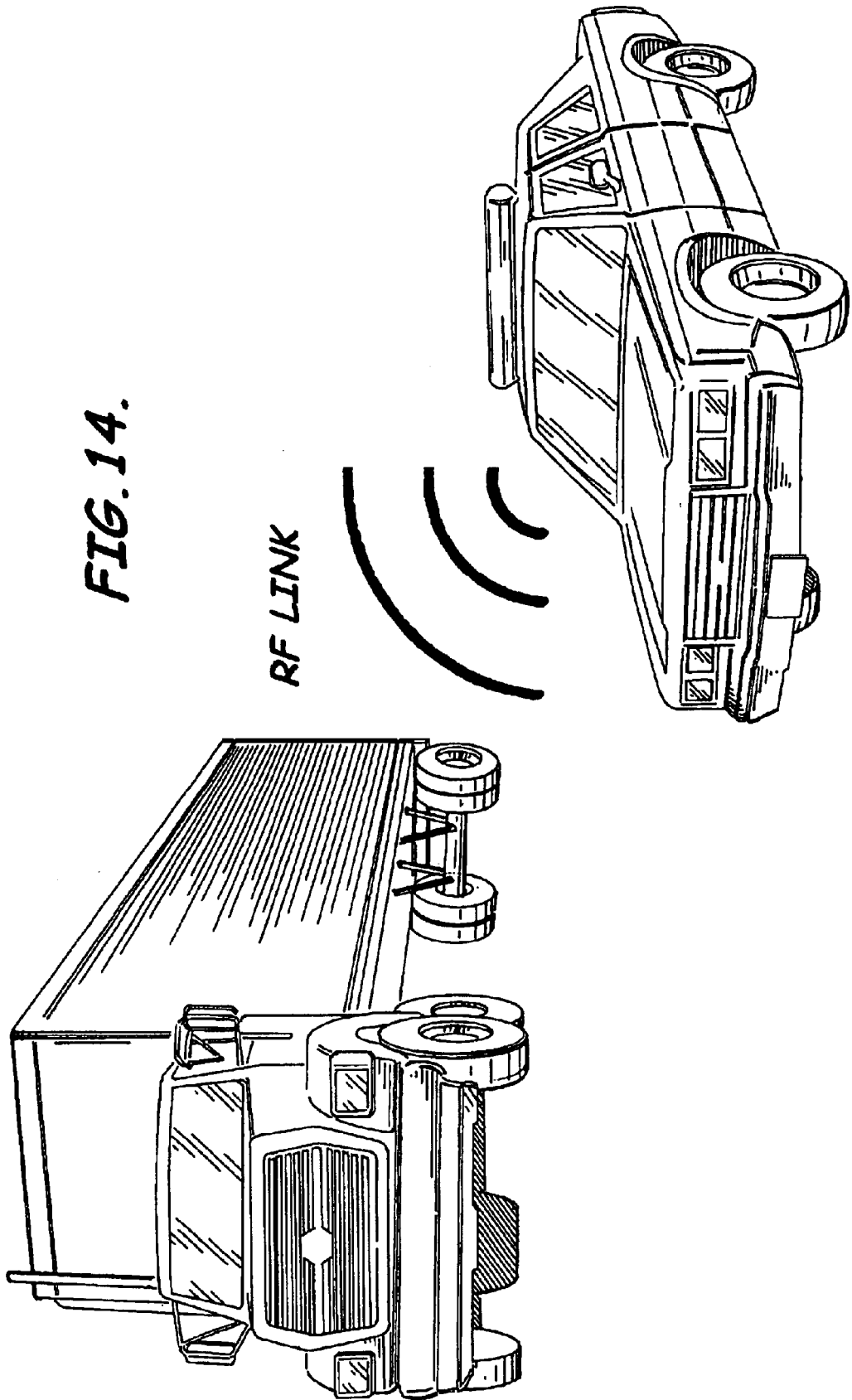
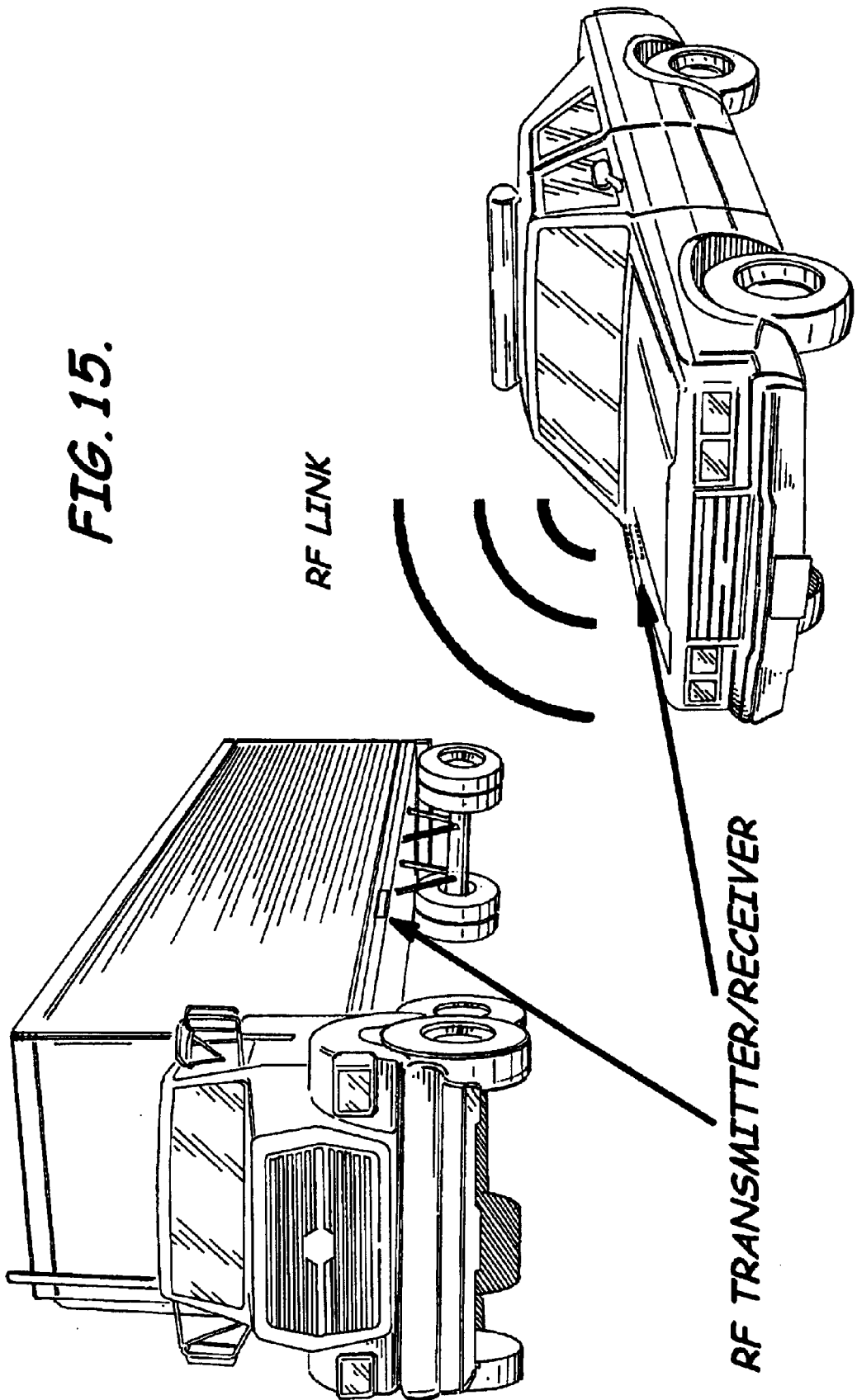
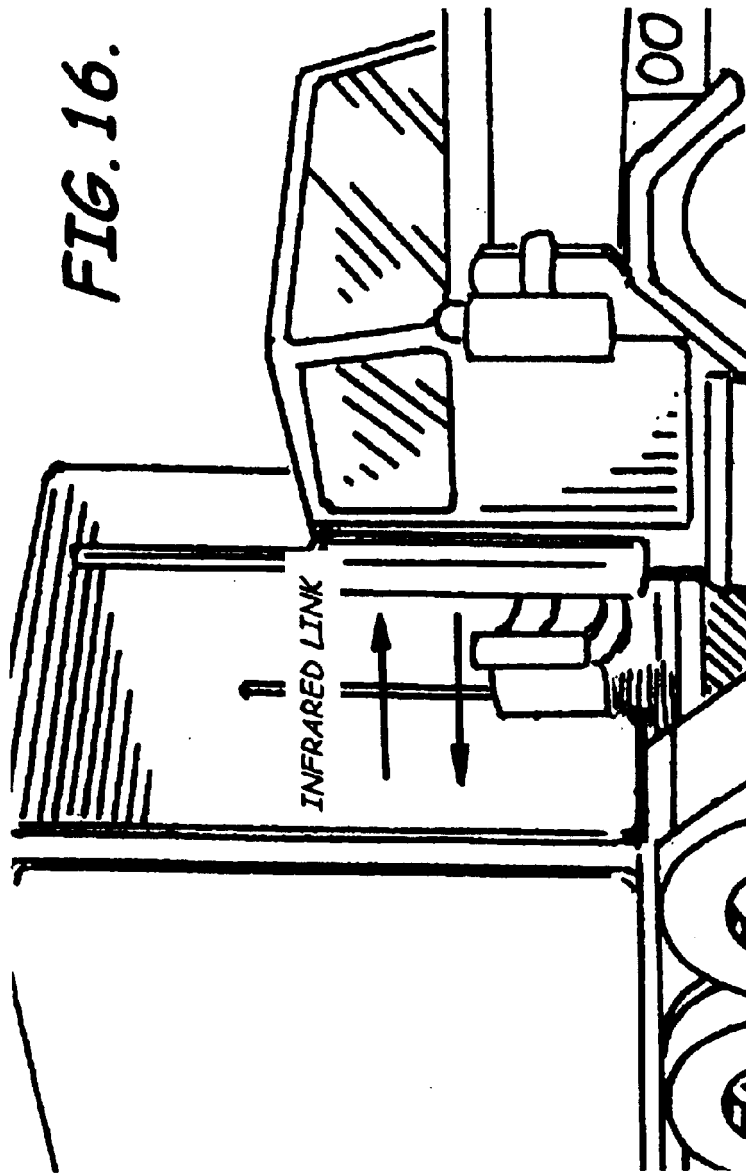

FIG. 15.





TRACTOR TO TRAILER IR COMMUNICATION

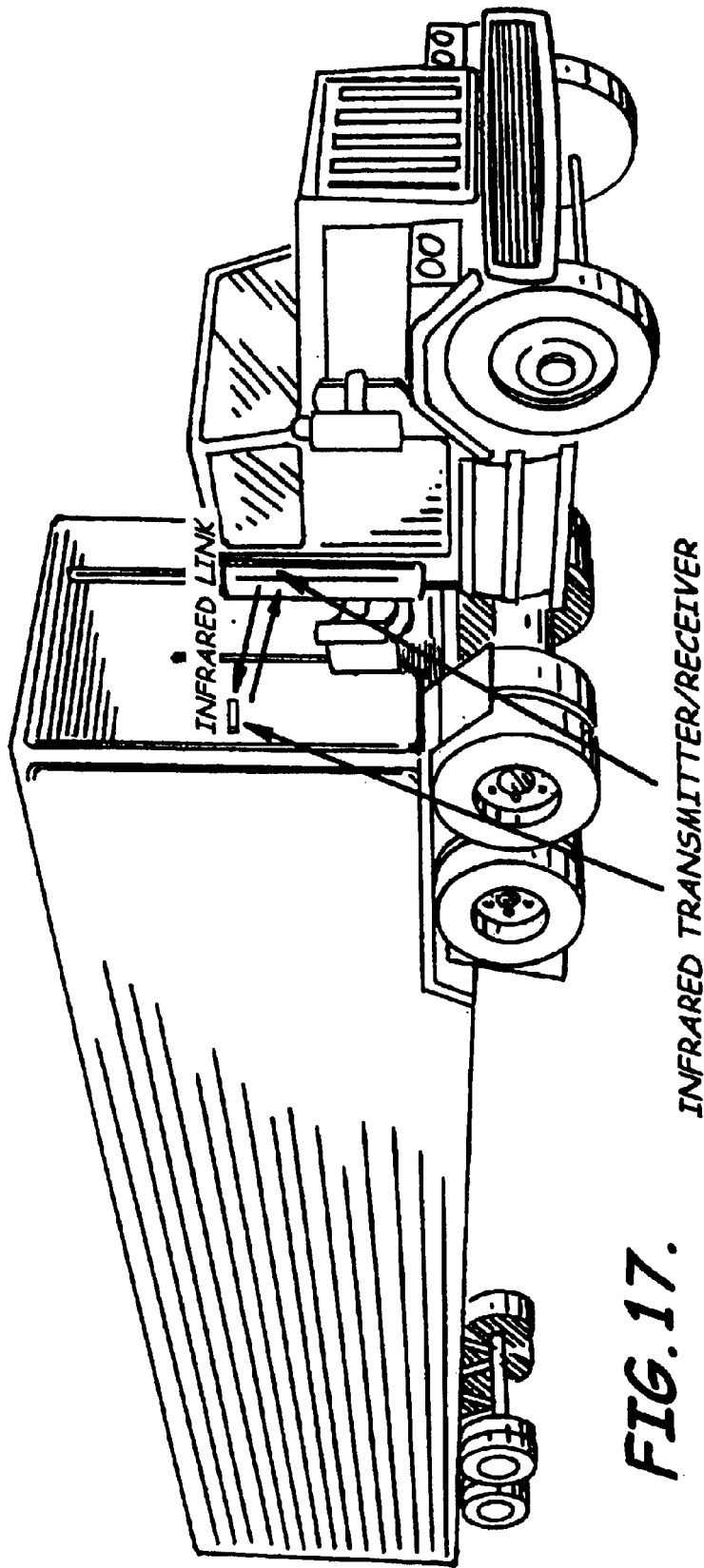
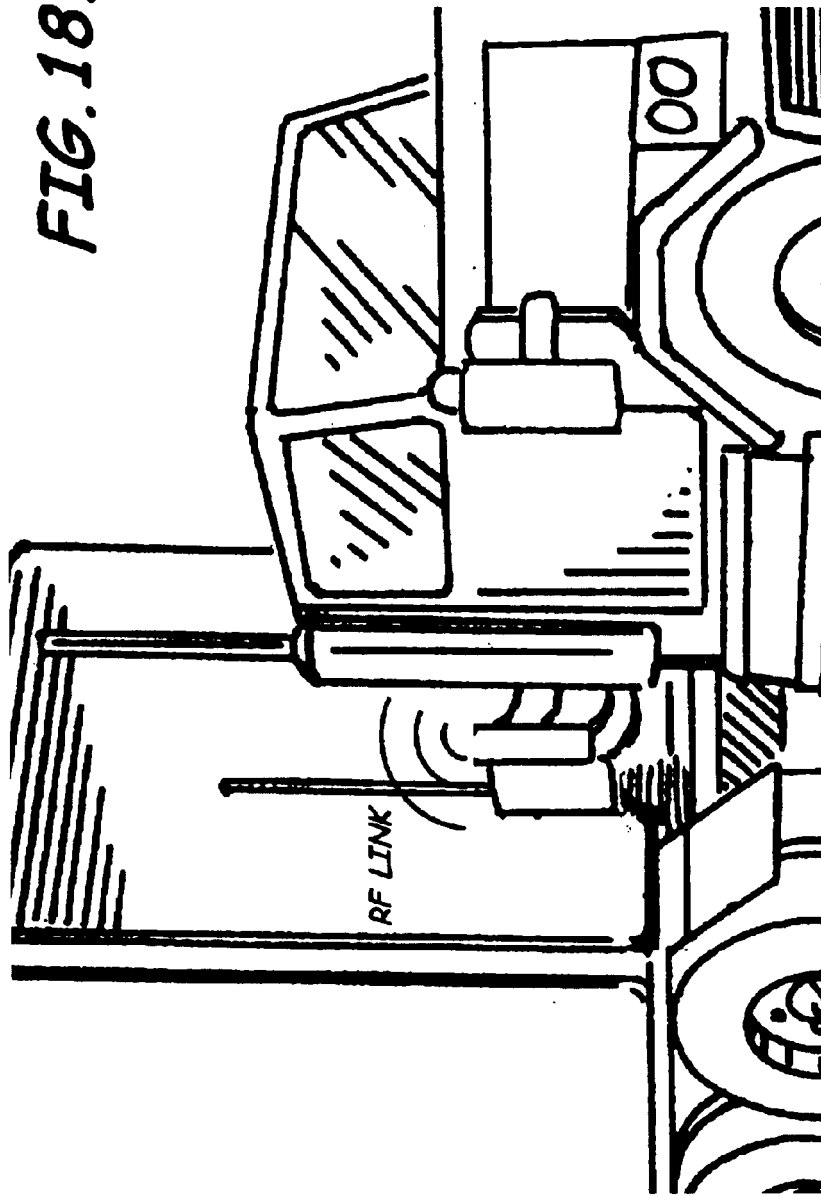

FIG. 17.

FIG. 18.



TRACTOR TO TRAILER RF COMMUNICATION

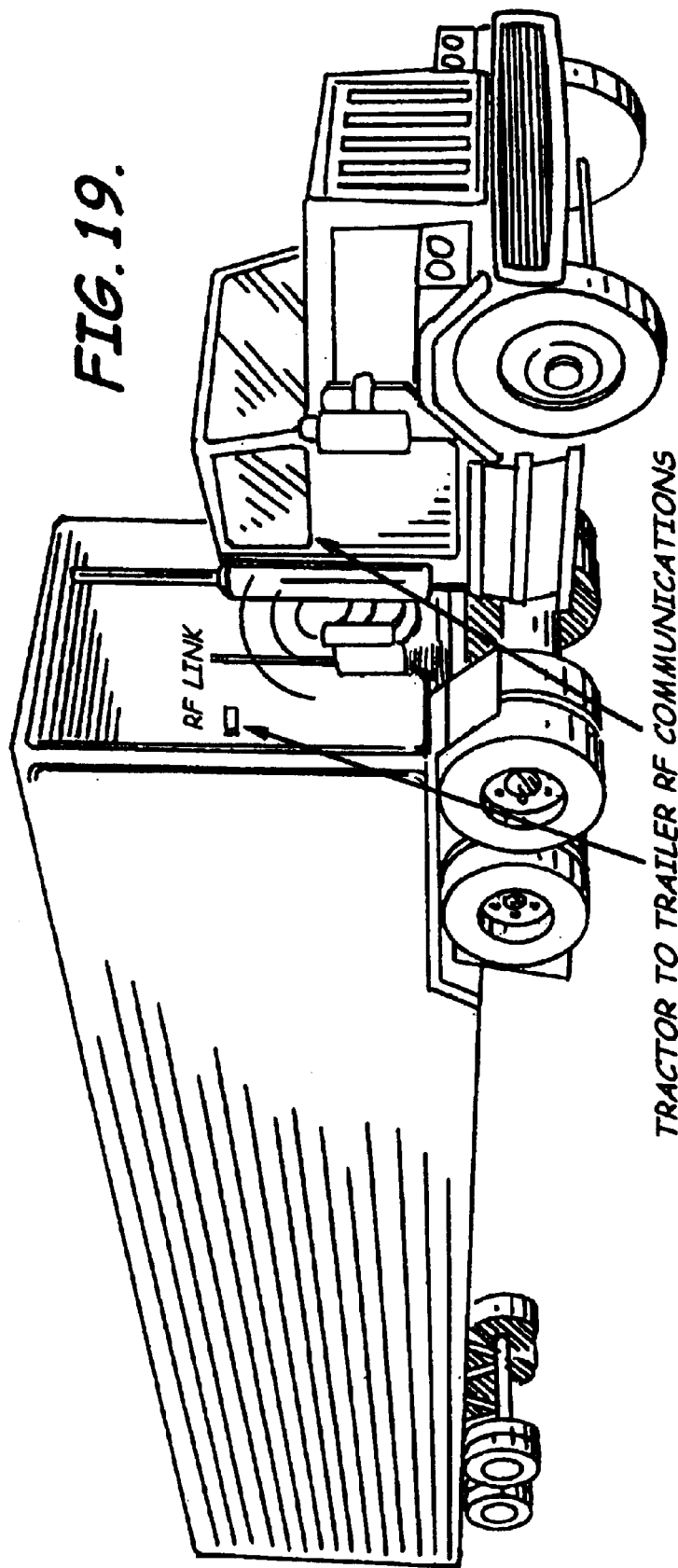
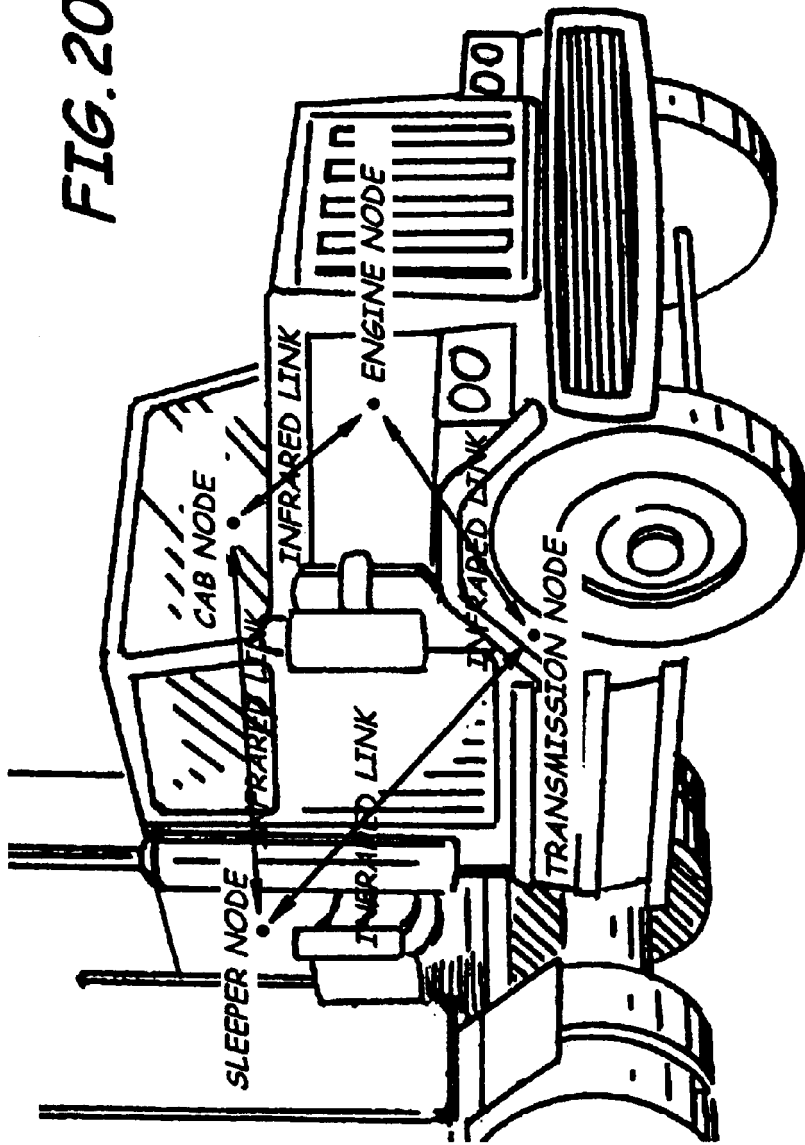

FIG. 19.

TRACTOR TO TRAILER RF COMMUNICATIONS

FIG. 20.



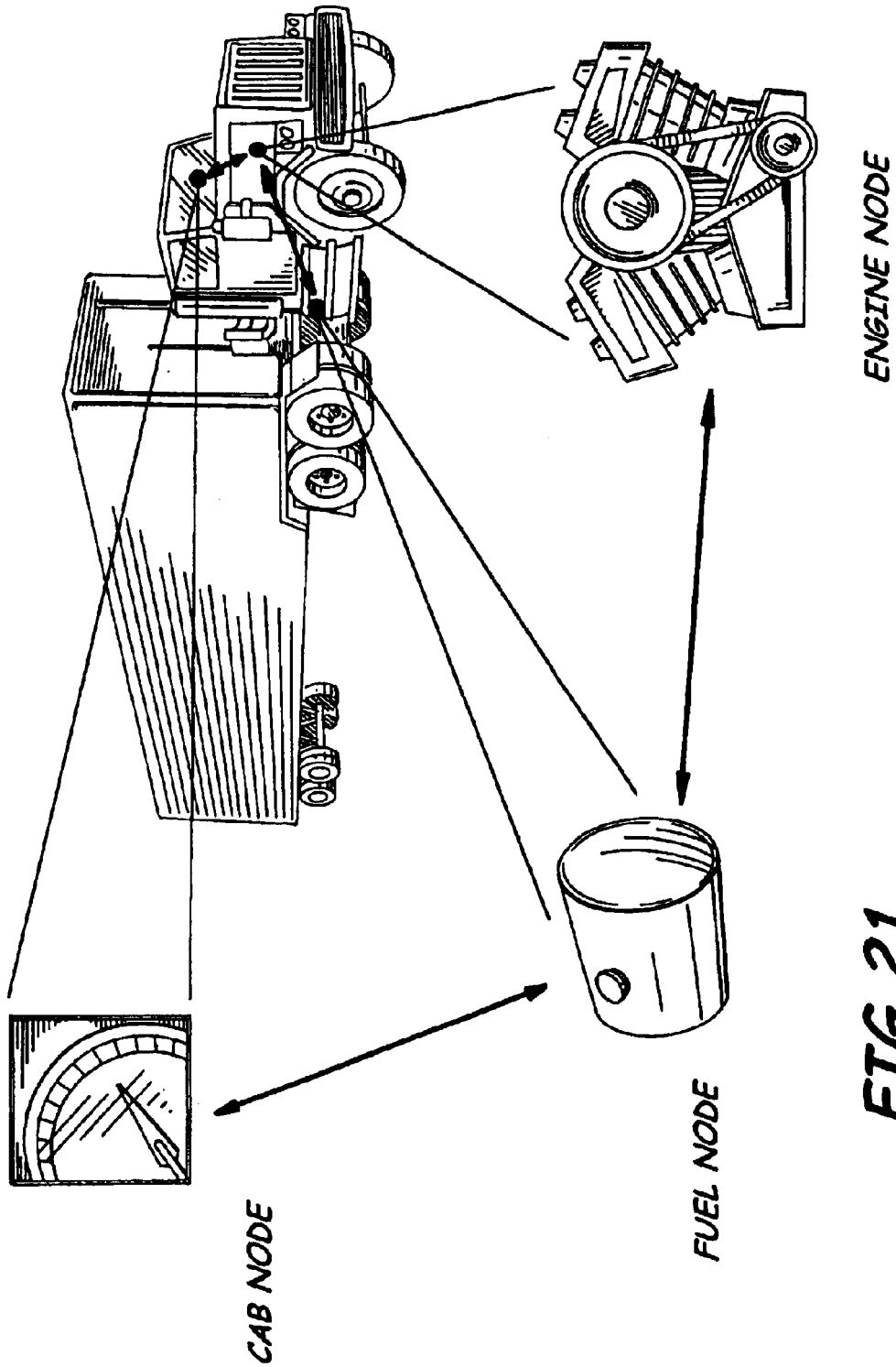

FIG. 21.

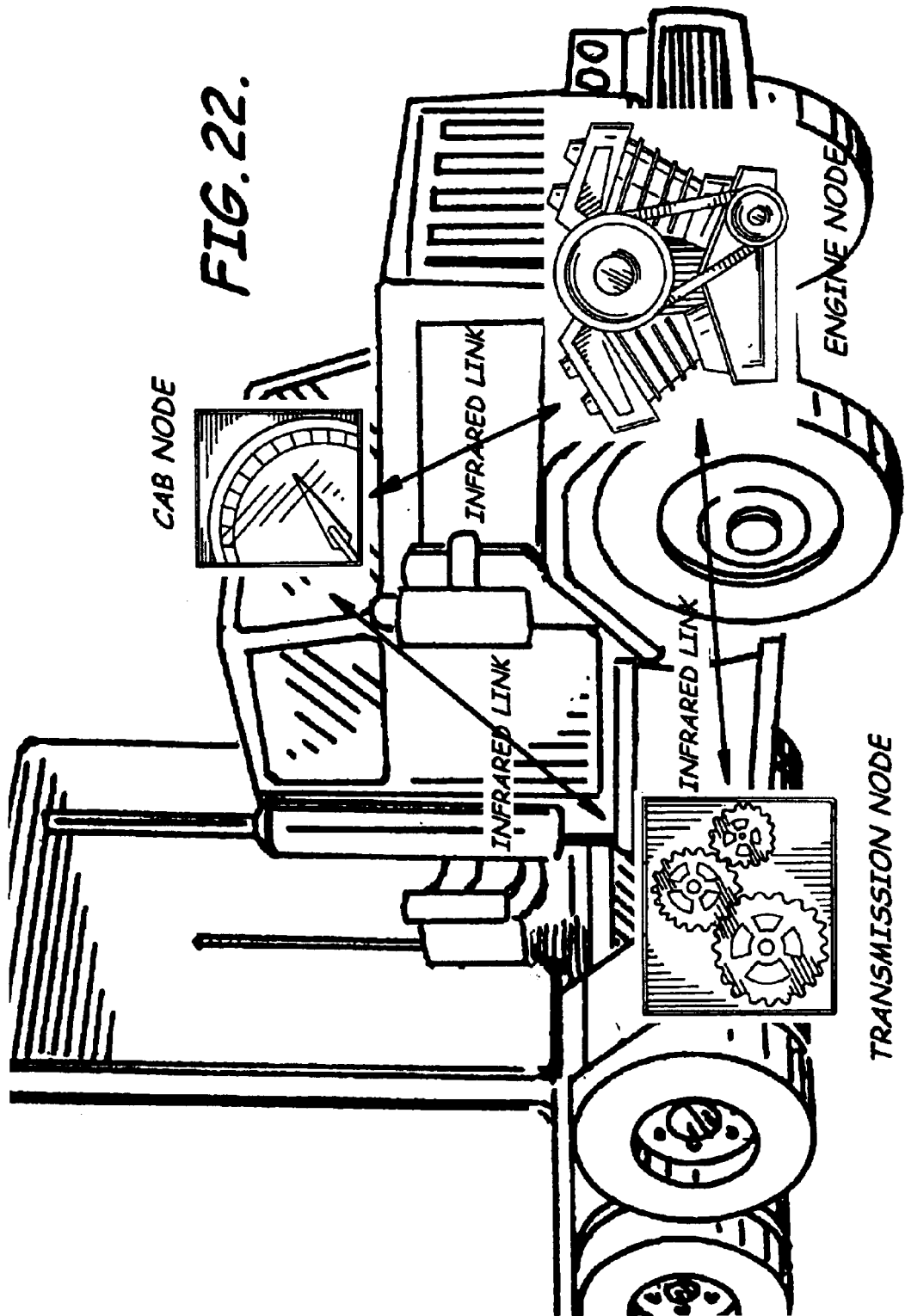
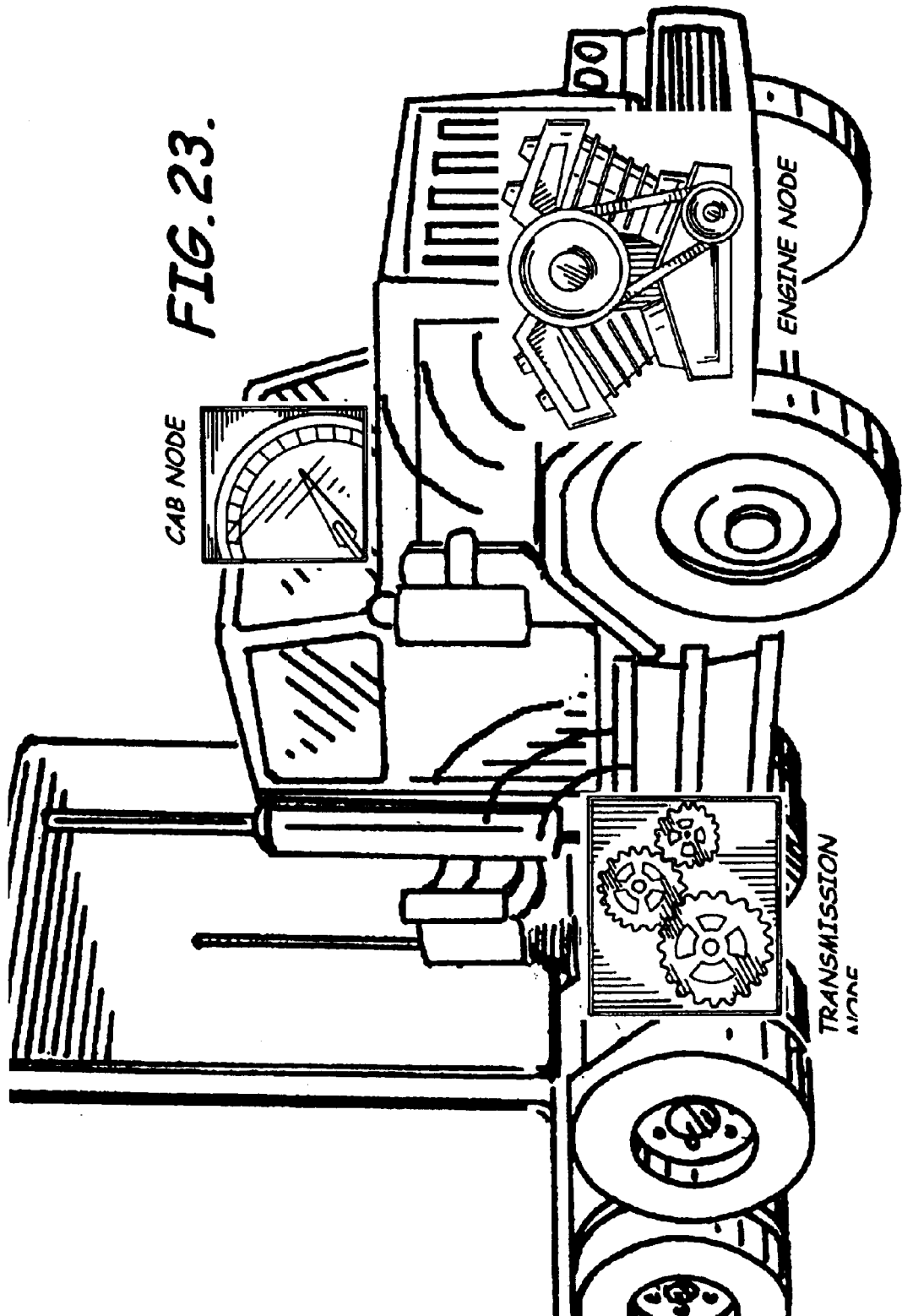

FIG. 23.



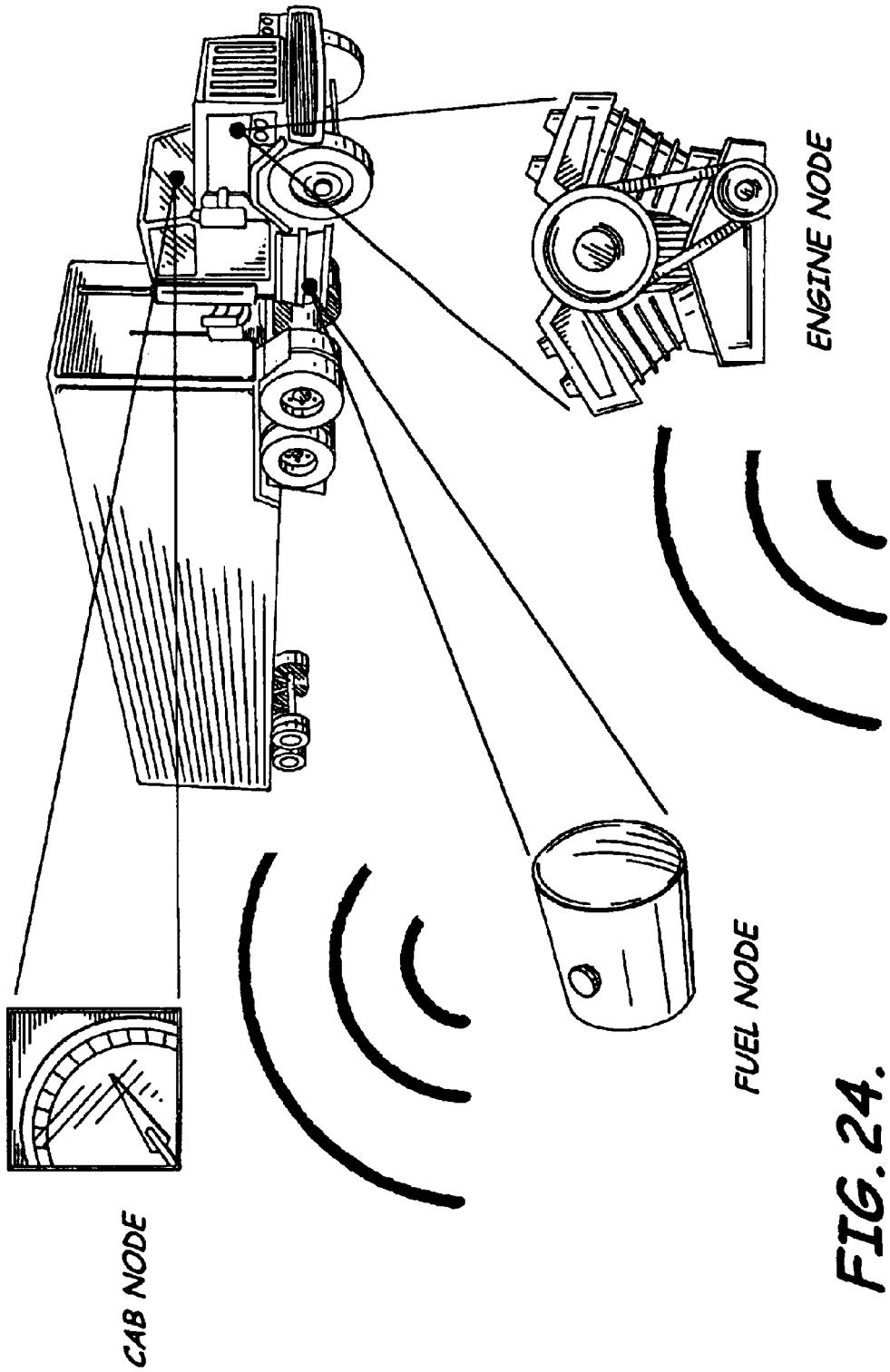

FIG. 24.

FIG. 25.

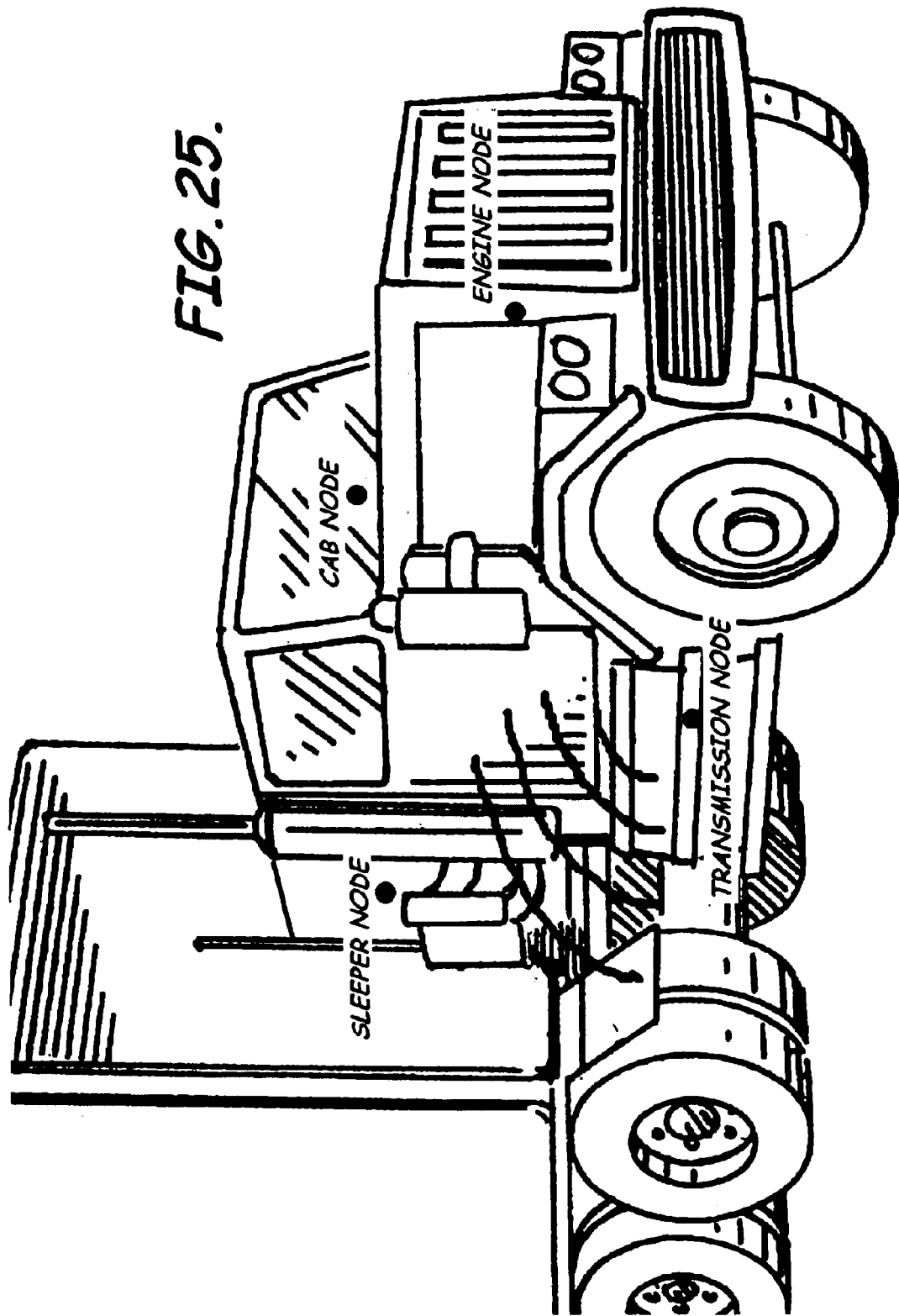

FIG. 26.

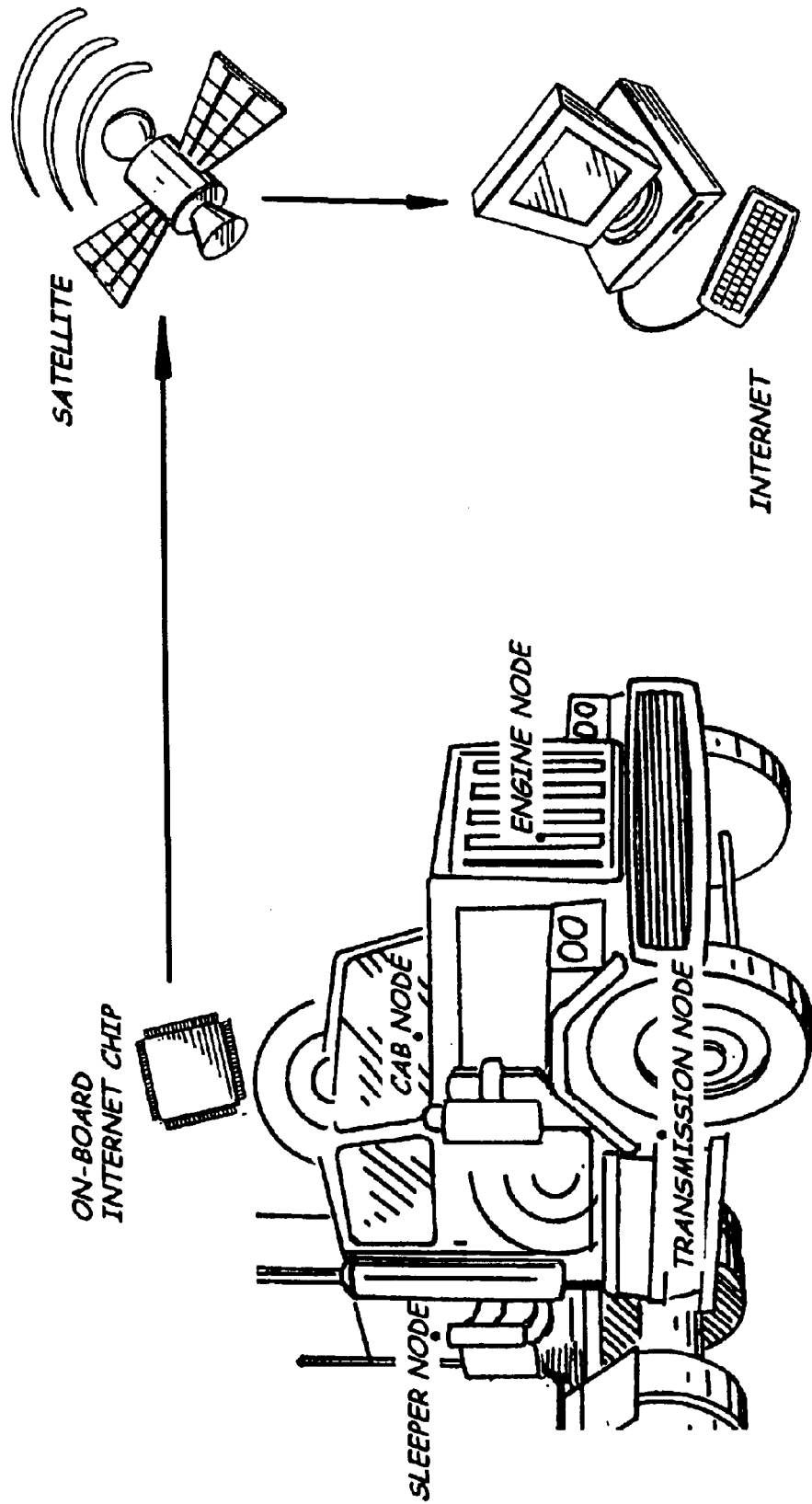
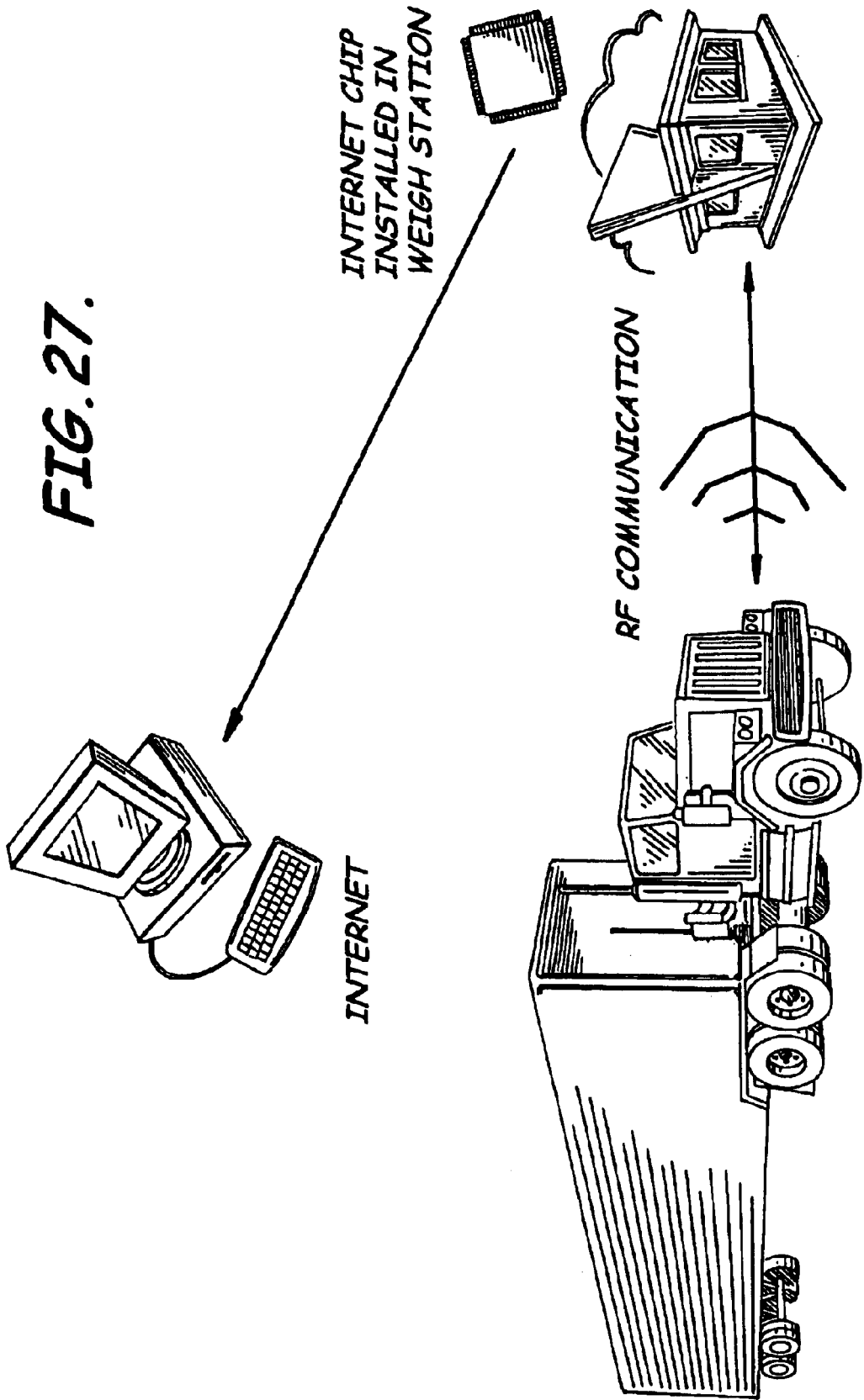

FIG. 27.



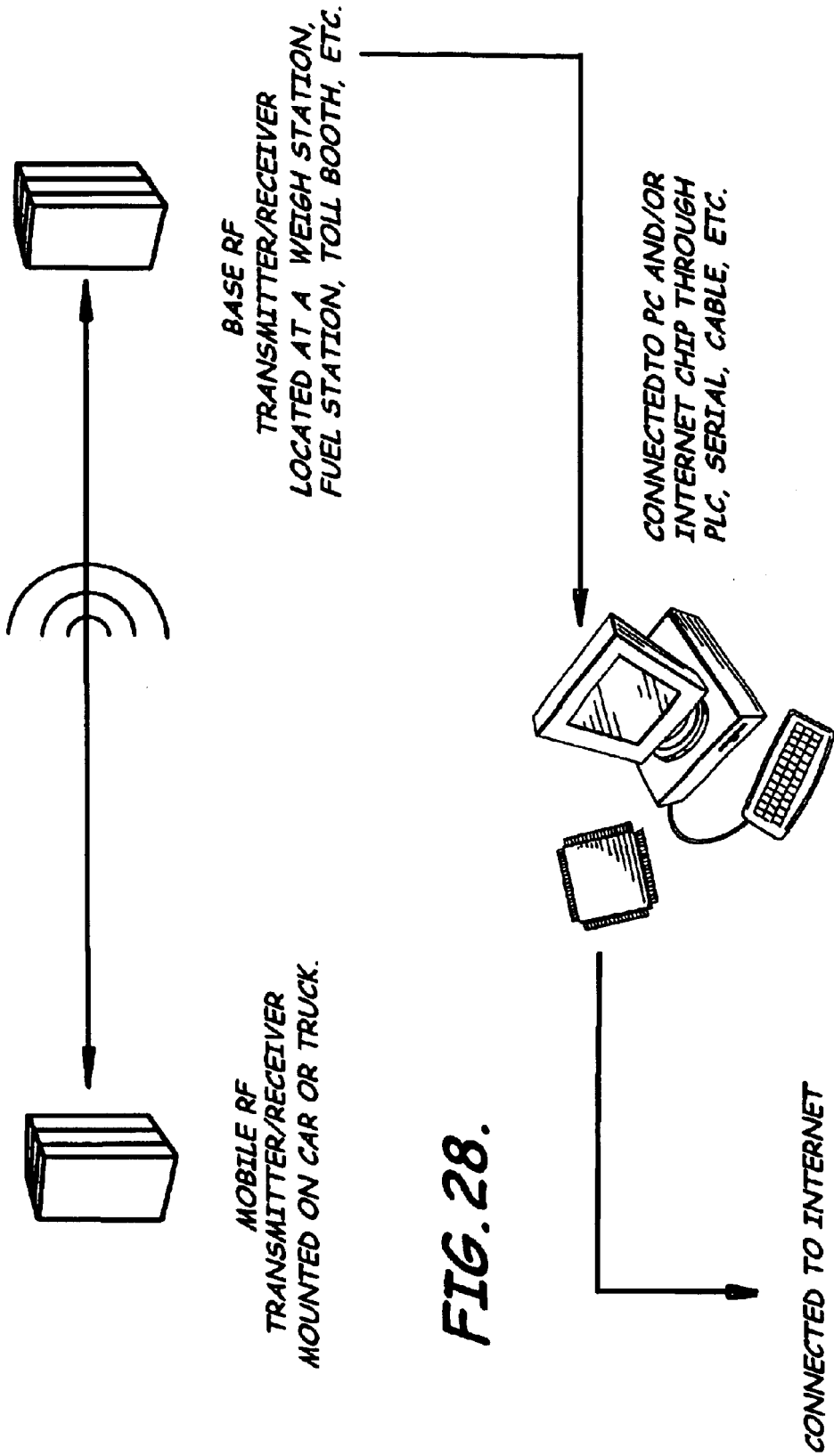
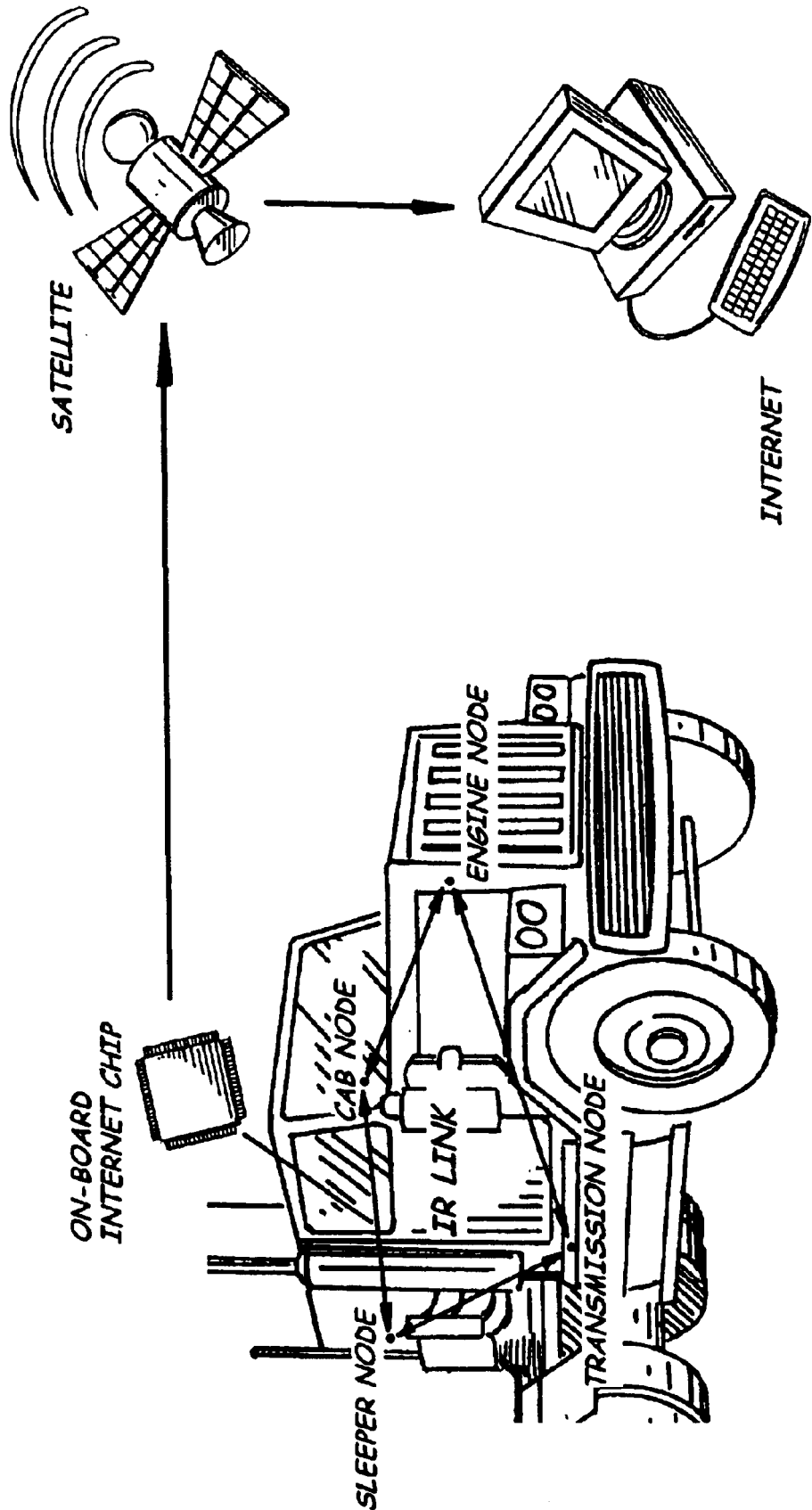
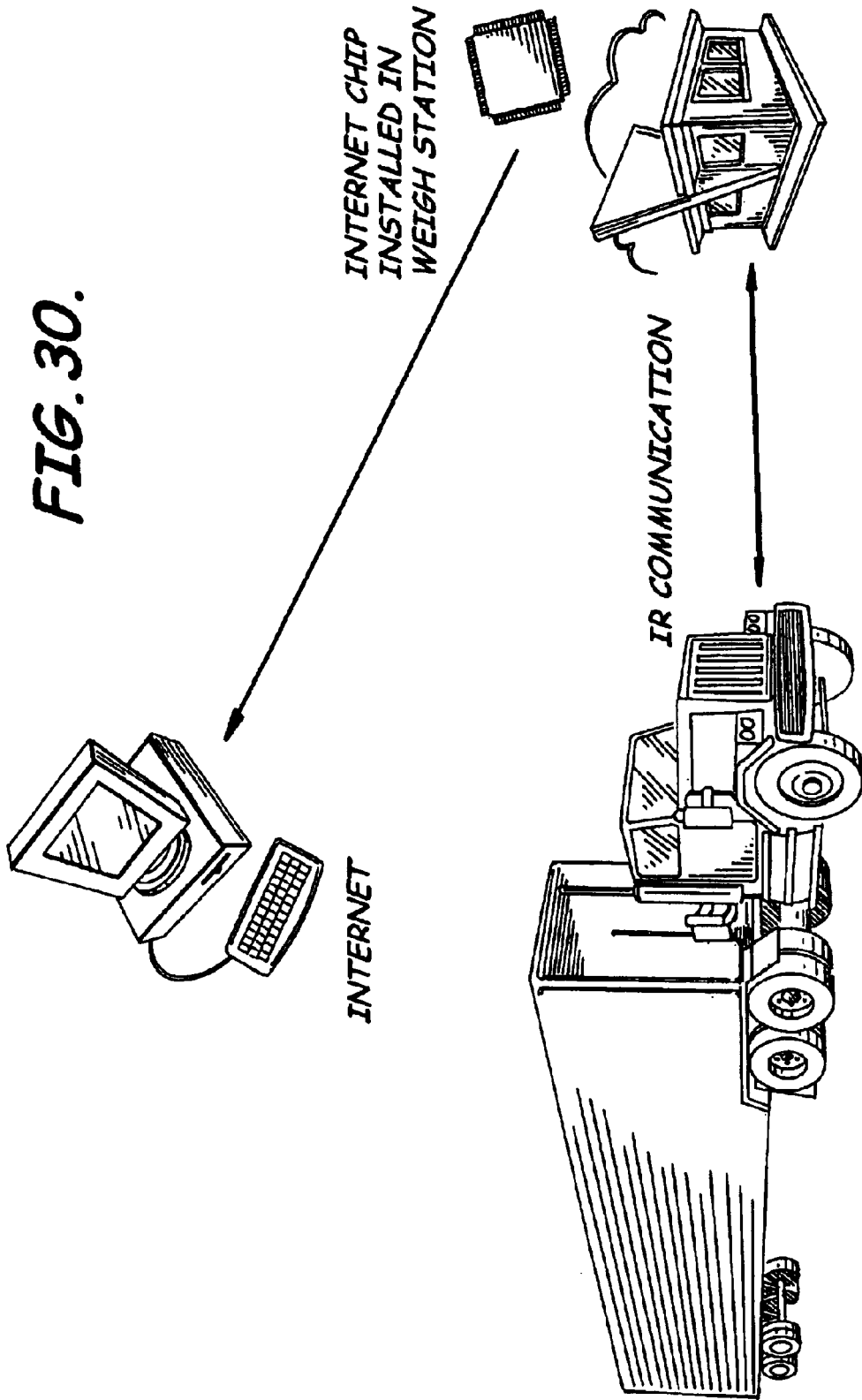

FIG. 28.

FIG. 29.





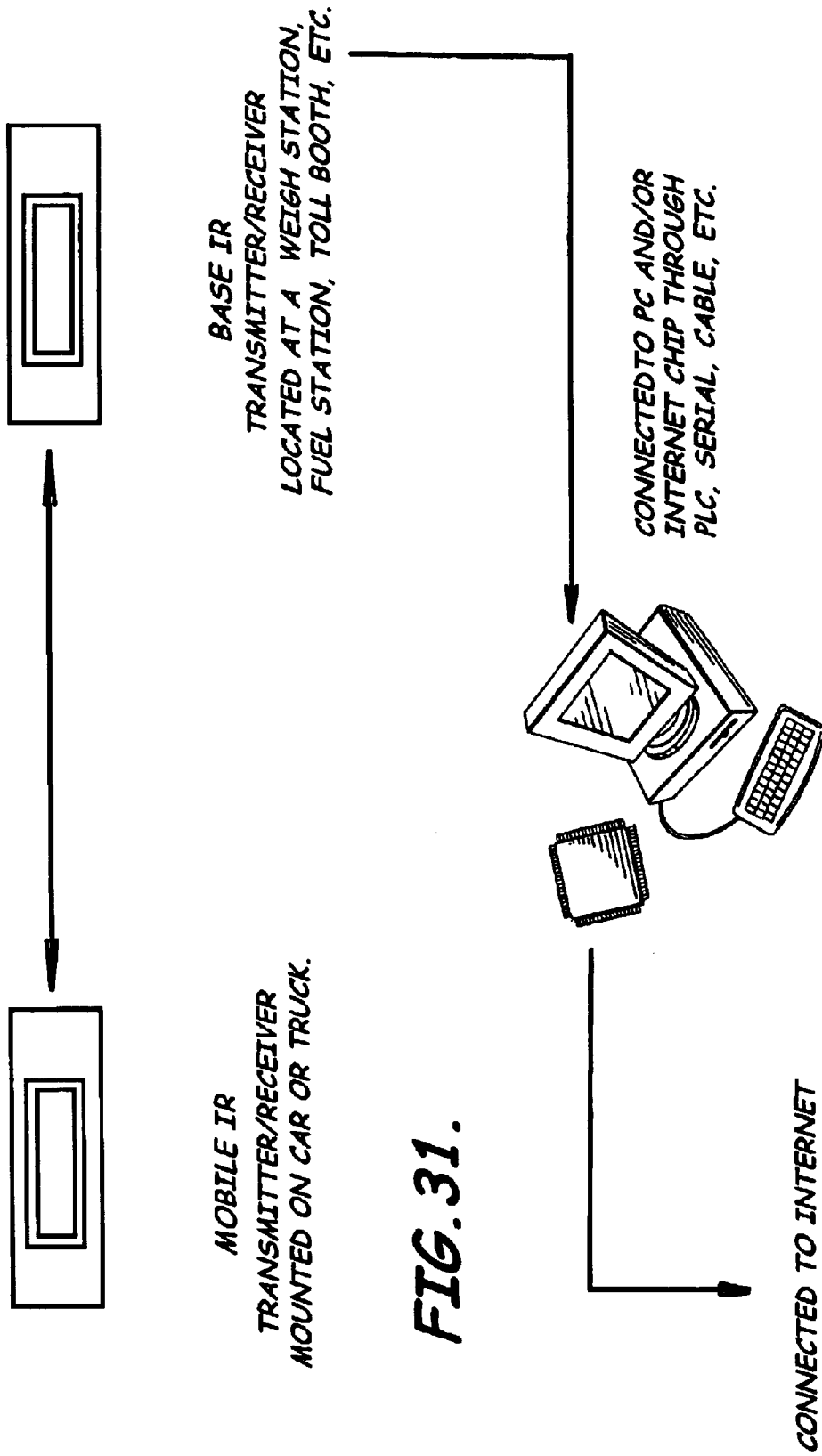

FIG. 31.

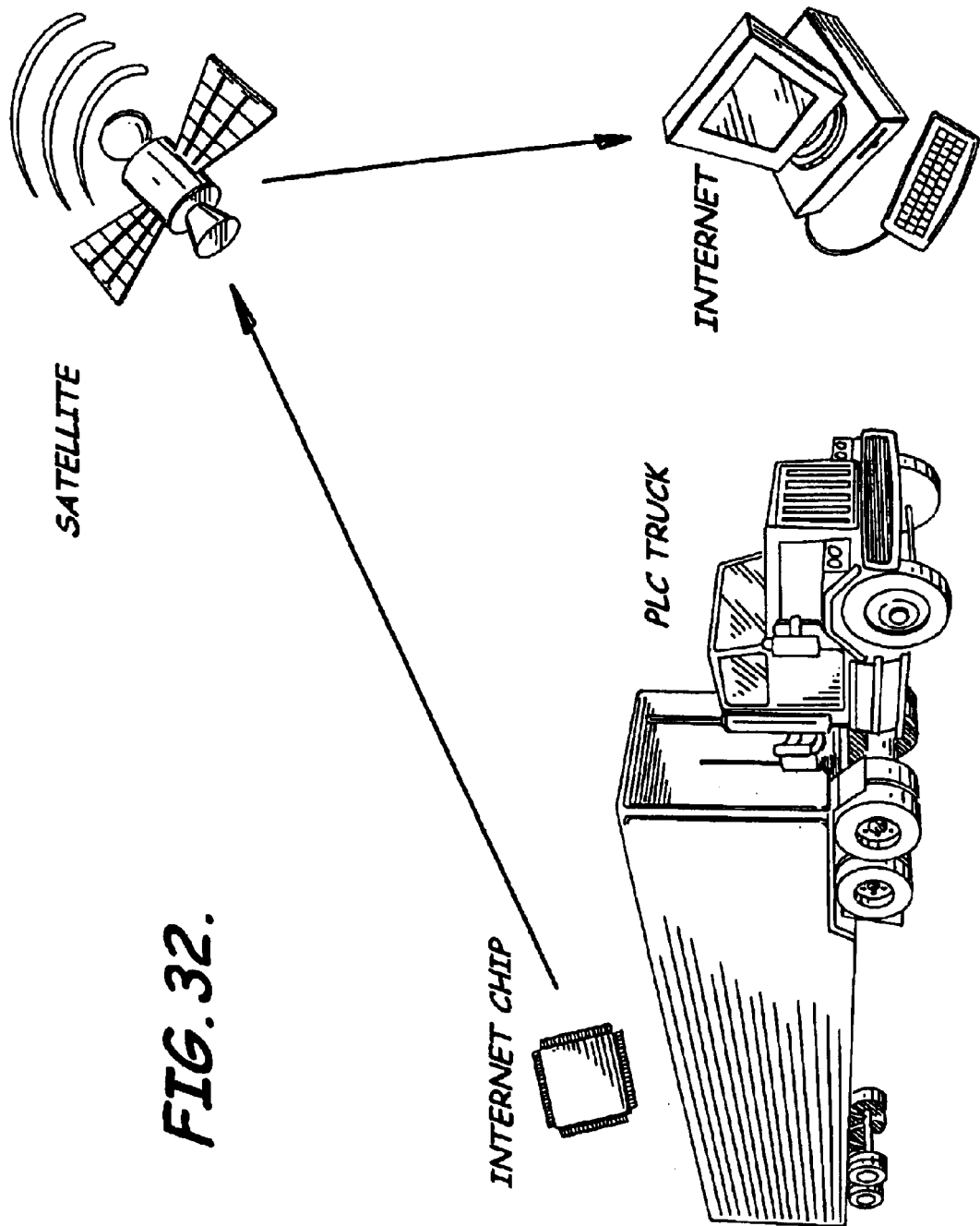
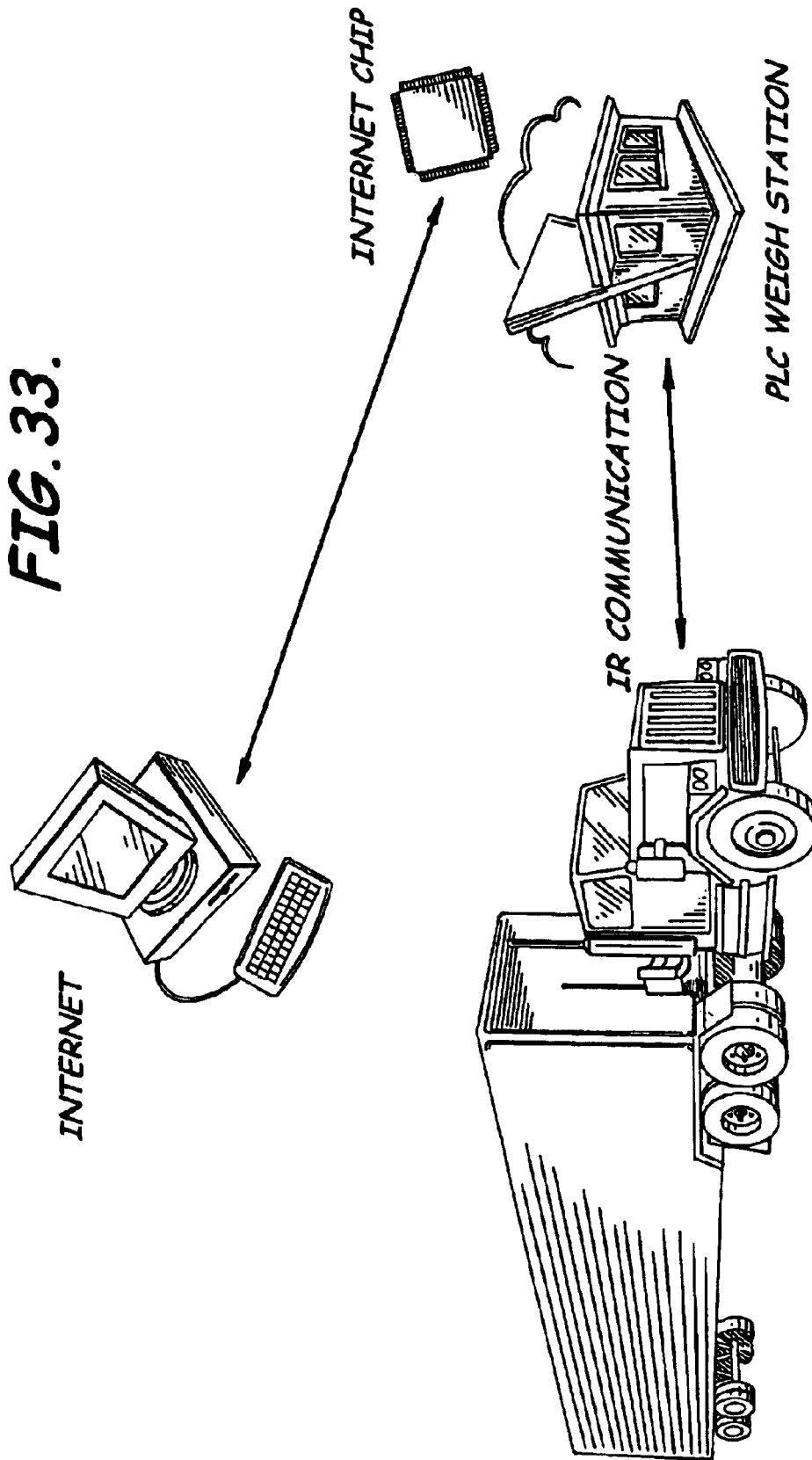

FIG. 32.



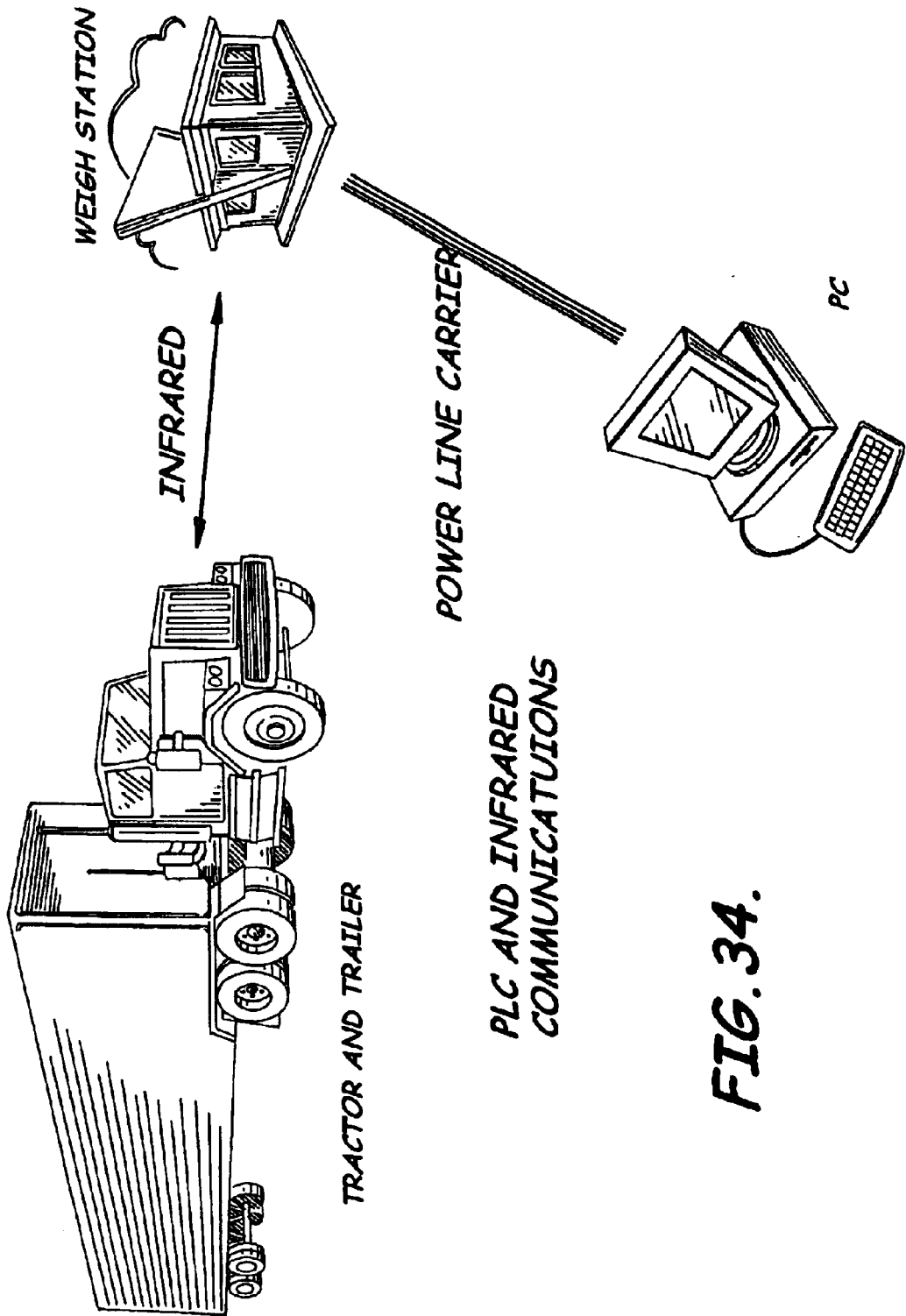

FIG. 34.

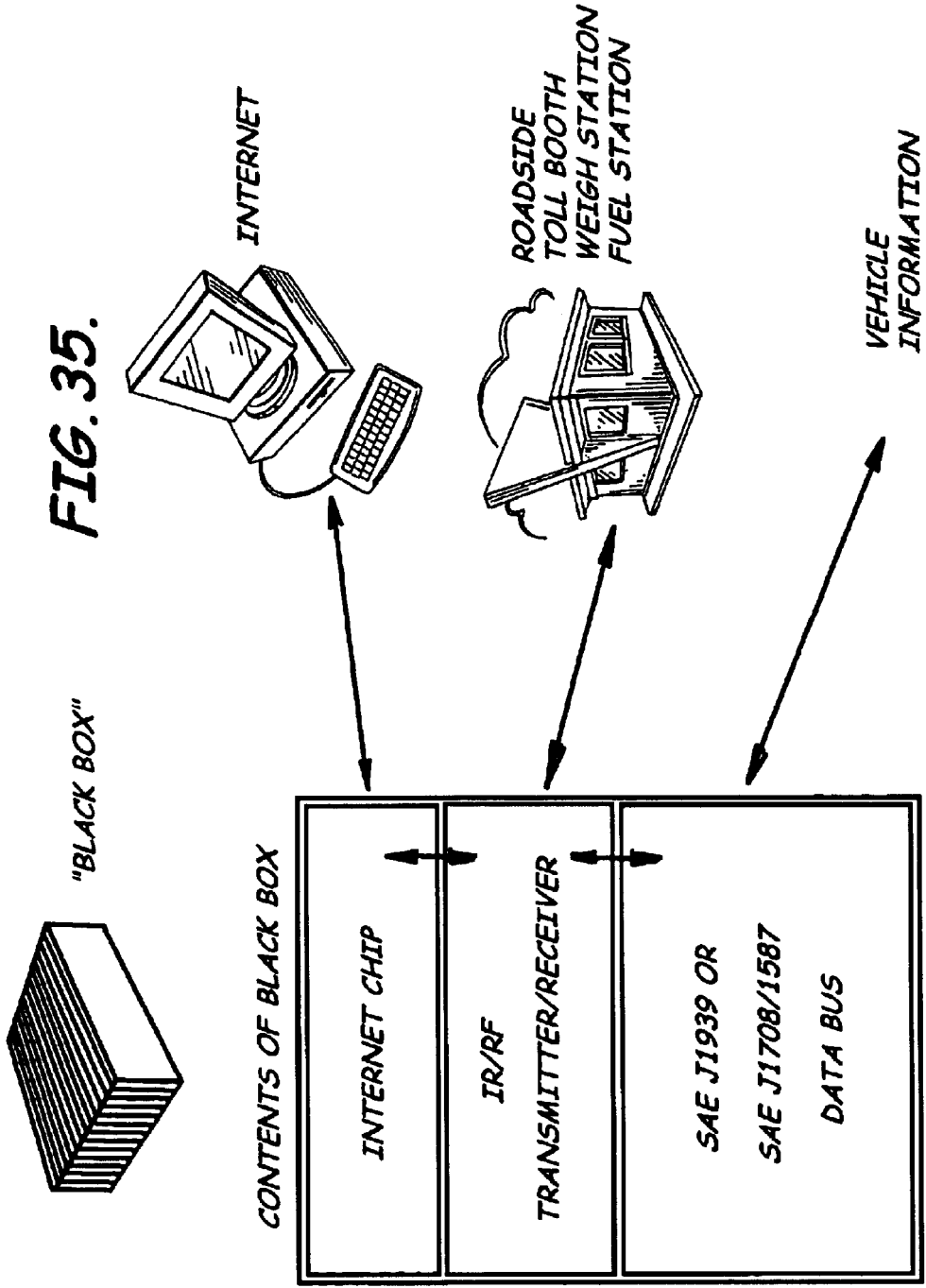
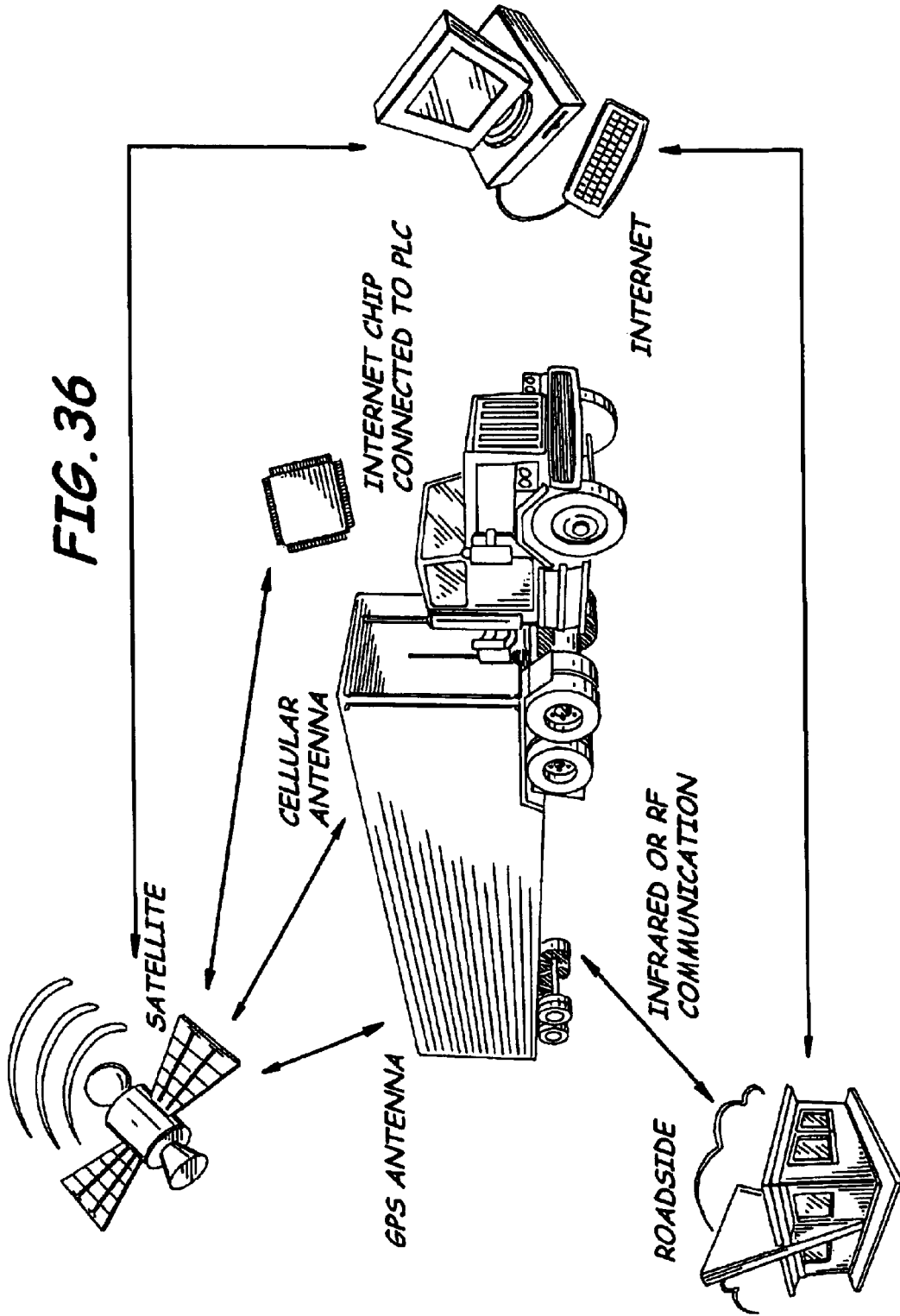

FIG. 35.



**SYSTEM, APPARATUS AND METHODS FOR
DATA COMMUNICATION BETWEEN
VEHICLE AND REMOTE DATA
COMMUNICATION TERMINAL, BETWEEN
PORTIONS OF VEHICLE AND OTHER
PORTIONS OF VEHICLE, BETWEEN TWO
OR MORE VEHICLES, AND BETWEEN
VEHICLE AND COMMUNICATIONS
NETWORK**

RELATED APPLICATIONS

This application is a continuation-in-part of U.S. patent application Ser. No. 10/007,032 filed on Nov. 8, 2001 and now U.S. Pat. No. 6,608,554, which is a continuation of U.S. patent application Ser. No. 09/569,995 filed on May 12, 2000 and now issued as U.S. Pat. No. 6,411,203, which is a continuation of U.S. patent application Ser. No. 08/907,861 filed on Aug. 8, 1997 and now issued as U.S. Pat. No. 6,064,299, which is a continuation-in-part of U.S. patent application Ser. No. 08/594,255 filed on Jan. 30, 1996 and now issued as U.S. Pat. No. 6,111,524, which is also a continuation-in-part of U.S. patent application Ser. No. 08/554,907 filed on Nov. 9, 1995 and now abandoned, and which are all incorporated herein by reference in their entireties.

BACKGROUND OF THE INVENTION

The present invention relates to the field of vehicle data communications and, more particularly, to data communications from a vehicle, such as a tractor or a trailer of a truck or an automobile, to a remote location, from a portion of a vehicle to other portions of the vehicle, from one vehicle to one or more other vehicles, or from a vehicle to a communications network.

Over the years, the vehicle industry and particularly the heavy duty vehicle industry has used tractor and trailer combinations to transport cargo over the roadways to various desired destinations. The tractors and trailer are conventionally mechanically coupled together so that the tractor efficiently and effectively pulls the trailer. Also, this mechanical coupling can often be an integral formed trailer with a tractor or cab region of a vehicle such as a pick-up truck, dump truck or other vehicle. Additionally, one or more other trailers can also be mechanically coupled to another trailer so that only one tractor or cab region pulls a plurality of trailers.

Various links between the tractor and the trailer provide vehicle subsystems, e.g., hydraulic, pneumatic, or electrical, with power and/or control signals to operate effectively. These subsystem have associated electrical conductors, pneumatic lines, or hydraulic lines extending between the tractor and trailer(s) so that these subsystems can effectively operate.

Data communications between a tractor and trailer for these subsystems also has been developed. An example of this data communications can be seen in U.S. Pat. No. 5,488,352 by Jasper titled "*Communications And Control System For Tractor/Trailer And Associated Method*" which is assigned to the common assignee of the present application. As described in this patent, the use of the Society of Automotive Engineering ("SAE") standard J1708 titled "*Serial Data Communications Between Microcomputer Systems In Heavy Duty Vehicle Applications*" and SAE standard J1939 are also known for data communications in the heavy duty vehicle environment.

Only recently, however, has the vehicle industries, and particularly the heavy duty vehicle industries, begun to use sophisticated electrical electronic subsystems in and associated with these vehicles to perform varied task that usually involve data manipulation and transmission. Previously, computers, controllers, and computer-type electrical systems were simply not found in these vehicles, such as the tractor and trailer combinations or recreational vehicles, in a significant manner. Much of this previous slow or lack of development and advances could be attributed, for example, to the lack of governmental or other authoritative initiatives which would have otherwise required systems to be installed on these heavy duty vehicles to include sophisticated electronics and data communications.

Although only recently have advances been made with data communications in the vehicle industries, and particularly the heavy duty vehicle industry, many of the advances require extensive retrofitting or extensive additions to the vehicle. Accordingly, many vehicle owners have been hesitant to adopt and purchase sophisticated electronics and data communications because of the expense and uncertainty with the advances in the technology. Yet, having the capability to monitor and communicate with the various electronic subsystems of a vehicle such as a tractor-trailer truck, recreational vehicle, or automobile can be beneficial to the driver, the owner, governmental officials or agencies, and others having an interest in the vehicle industries.

SUMMARY OF THE INVENTION

With the foregoing in mind, the present invention advantageously provides a system, an apparatus and methods of data communication between a vehicle and a remote data communication terminal so that various operating characteristics of the vehicle can be monitored or observed. The remote data communications terminal, for example, can be in a portable computer, a base station, another vehicle, a building, or a building structure. The present invention also advantageously provides a system, an apparatus and methods of data communication for discretely and compactly communicating data between a vehicle and a remote data communication terminal, between portions of a vehicle, between vehicles, and between a vehicle and a communication network. The present invention additionally provides a system, an apparatus and methods of data communication which is readily adapted to existing vehicle data communication technology and does not require either extensive retrofitting or extensive and expensive additions to existing vehicle data communication technology. The present invention further advantageously provides a system, an apparatus and methods of data communication so that when the apparatus is mounted to a vehicle a third party would not readily recognize that the vehicle is equipped for data communications from the vehicle to a remote data communications terminal to thereby reduce risk of theft, damage, or interference with the vehicle communication.

More particularly, a combination of a vehicle and a data communication apparatus are provided according to the present invention. Although the vehicle is preferably a tractor and a trailer connected to the tractor, as understood by those skilled in the art other various types of vehicles, including various types of heavy duty vehicles, can be used as well according to the present invention. The tractor preferably includes a cab. The cab can also be within an automobile, truck, train, airplane, or boat as well. The data communications apparatus is preferably connected to the tractor and the trailer for communicating data to and from the tractor and the trailer to a remote data terminal. The data

communications apparatus preferably includes a plurality of electrical conductors associated with and extending between the tractor and the trailer. A connector preferably is connected to, e.g., in series with, the plurality of electrical conductors and positioned in the cab of the tractor or other vehicle. It will be understood by those skilled in the art, however, that various other positions associated with the tractor or other portions of a vehicle can be used as well according to the present invention, e.g., along the outer peripheral walls of a vehicle, mounted to a window of a vehicle, mounted to or within a trailer, or mounted to an engine or an engine compartment of a vehicle. The apparatus also includes vehicle data communications protocol converter connected to the plurality of electrical conductors to convert a first data communications protocol used to communicate data along the plurality of electrical conductors to a second data communications protocol. For example, the second data communications protocol is preferably one of either an infrared data communications protocol, a radio frequency ("RF") data communications protocol, including Bluetooth and Institute for Electronic and Electrical Engineers ("IEEE") 802.11 standards, an Internet or other global communications network data protocol, a local area network data communications protocol, other wireless data communications protocol, or a power line carrier ("PLC") communications protocol, including Spread Spectrum PLC protocol. A first transceiver preferably is associated with the connector and is connected to the vehicle data communications protocol converter to transmit and receive the second data communications protocol. A remote data communication terminal which preferably includes a second transceiver to transmit the second data communications protocol to the first transceiver and receive the data communications protocol from the first transceiver.

Also, according to another aspect of the present invention, the data communication apparatus preferably includes a plurality of electrical conductors associated with a vehicle. A vehicle data communications protocol converter is preferably connected to the plurality of electrical conductors to convert a first data communications protocol associated with data communications along the plurality of electrical conductors to a second data communications protocol. The apparatus also preferably includes a transceiver connected to the vehicle data communications protocol converter to transmit the data communications protocol from the vehicle and receive the data communications protocol from a remote data communications terminal.

According to yet another aspect of the present invention, an apparatus for data communications associated with a vehicle preferably includes a transceiver housing adapted to be connected to at least one of a plurality of electrical conductors associated with the vehicle. A vehicle data communications protocol converter is preferably positioned in the transceiver housing to convert a first data communications protocol associated with data communications along the plurality of electrical conductors to a second data communications protocol. The apparatus also has a transceiver positioned within the transceiver housing and connected to the vehicle data communications protocol converter to transmit the second data communications protocol from the vehicle and receive the data communications protocol from a remote data communications terminal.

Still according to another aspect of the present invention, an apparatus for data communications associated with a vehicle preferably includes a transceiver housing mounted to a vehicle. The transceiver housing is preferably a vehicle light housing such as a side light marker housing. A vehicle

data communications protocol converter is preferably positioned in the transceiver housing to convert a first data communications protocol associated with data communications along the plurality of electrical conductors to a second data communications protocol. A transceiver is preferably positioned within the transceiver housing and is connected to the vehicle data communications protocol converter to transmit the second data communications protocol from the vehicle and receive the data communications protocol from a remote data communications terminal.

A method of data communications associated with a vehicle is also provided according to the present invention. The method preferably includes providing a plurality of electrical conductors associated with a vehicle and converting a first data communications protocol associated with data communications along the plurality of conductors to a second data communications protocol. The second data communications protocol is preferably one of either an infrared data communications protocol, a radio frequency ("RF") data communications protocol, including Bluetooth and IEEE 802.11 Standards, an Internet or other global communications network protocol, a local area network data communications protocol, other wireless data communications protocols, or a power line carrier communications protocol, including Spread Spectrum PLC protocol. The method also includes transmitting the data communications protocol from the vehicle to a remote data communications terminal, to other portions of the vehicle, to one or more other vehicles, or to a communications network.

BRIEF DESCRIPTION OF THE DRAWINGS

Some of the objects and advantages of the present invention having been stated, others will become apparent as the description proceeds when taken in conjunction with the accompanying drawings in which:

FIG. 1 is a side elevational view of a vehicle in an embodiment as a tractor/trailer truck in combination with an apparatus for data communications between the truck and a remote data communication terminal according to the present invention;

FIG. 2 is a perspective view of an apparatus for data communications between a vehicle and a remote data communications terminal having a transceiver positioned in a cab of a tractor of a tractor/trailer truck according to a first embodiment of the present invention;

FIG. 3 is a perspective view of an apparatus for data communications between a vehicle and a remote data communications terminal having a transceiver positioned in a cab of a tractor of a tractor/trailer truck and a remote data communications terminal positioned in the hands of a driver according to a first embodiment of the present invention;

FIG. 4 is an exploded perspective view of a connector, a transceiver housing, and a transceiver of an apparatus for data communications between a vehicle and a remote data communications terminal according to a first embodiment of the present invention;

FIG. 5 is a schematic block diagram of an apparatus for data communications between a vehicle and a remote data communications terminal according to the present invention;

FIG. 6 is a fragmentary side elevational view of an apparatus for data communications between a vehicle and a remote data communications terminal according to a second embodiment of the present invention;

FIG. 7 is an enlarged perspective view of a vehicle light housing in the form of a vehicle side light marker housing

5

having portions thereof broken away for clarity and having a transceiver positioned therein of an apparatus for data communications between a vehicle and a remote data communications terminal according to a second embodiment of the present invention;

FIG. 8 is an enlarged perspective view of a connector, a transceiver housing, and a transceiver positioned in the transceiver housing of an apparatus for data communications between a vehicle and a remote data communications terminal according to a third embodiment of the present invention;

FIG. 9 is a sectional view of a transceiver housing of an apparatus for data communications between a vehicle and a remote data communications terminal taken along line 9—9 of FIG. 8 according to a third embodiment of the present invention;

FIG. 10 is a side elevational view of an apparatus for data communications between a vehicle and a remote data communications terminal according to a third embodiment of the present invention;

FIG. 11 is schematic block diagram of an apparatus for data communications between a vehicle and a remote data communications terminal according to the present invention;

FIG. 12 is a perspective environmental view of a system for data communication between vehicles using an infrared communication link from a cab of tractor through a window to a cab of a security automobile according to a fourth embodiment of the present invention the present invention;

FIG. 13 is a perspective environmental view of an apparatus for data communication between a trailer of a heavy duty vehicle and a security automobile using an infrared communication link mounted to a side panel of the trailer and a side panel of the security vehicle according to a fifth embodiment of the present invention;

FIG. 14 is a perspective environmental view of a system for data communication between vehicles using a radio frequency link from a cab of a tractor to a cab of a security automobile according to a sixth embodiment of the present invention;

FIG. 15 is a perspective environmental view of an apparatus for data communication between vehicles using a radio frequency link mounted to a side panel of a trailer and a side panel of a security vehicle according to a seventh embodiment of the present invention;

FIG. 16 is a perspective view of a system for data communication between a tractor and a trailer of a heavy duty vehicle using an infrared link according to an eighth embodiment of the present invention;

FIG. 17 is a perspective view of a system for data communication between a tractor and a trailer of a heavy duty vehicle using an infrared link according to the eighth embodiment of the present invention;

FIG. 18 is a perspective view of a system for data communication between a tractor and a trailer of a heavy duty vehicle using a radio frequency link according to an eighth embodiment of the present invention;

FIG. 19 is a perspective view of a system for data communication between a tractor and a trailer of a heavy duty vehicle using a radio frequency link according to the eighth embodiment of the present invention;

FIG. 20 is a perspective environmental view of a system for data communication between portions of a vehicle using an infrared link according to a ninth embodiment of the present invention;

6

FIG. 21 is an exploded perspective view of a system for data communication between a portion of a tractor and to a portion of a trailer of a heavy duty vehicle using an infrared link according to a tenth embodiment of the present invention;

FIG. 22 is a perspective environmental view of a system for data communication between portions of a vehicle using an infrared link according to an eleventh embodiment of the present invention;

FIG. 23 is a perspective environmental view of a system for data communication between portions of a vehicle using a radio frequency link according to a twelfth embodiment of the present invention;

FIG. 24 is an exploded perspective view of a system for data communication between a portion of a tractor and to a portion of a trailer of a heavy duty vehicle using a radio frequency link according to a thirteenth embodiment of the present invention;

FIG. 25 is a perspective environmental view of a system for data communication between portions of a vehicle using a radio frequency link according to an fourteenth embodiment of the present invention;

FIG. 26 is a schematic view of a system for data communications between portions of a vehicle and a communications network using a radio frequency link and to a remote data terminal through the communications network according to a fifteenth embodiment of the present invention;

FIG. 27 is a schematic view of a system for data communications between a vehicle and a remote data terminal or communications network using a radio frequency link and then to remote data terminal through the communications network according to a sixteenth embodiment of the present invention;

FIG. 28 is a schematic view of an apparatus for data communications having a mobile radio frequency transmitter and receiver mounted on a truck or automobile and a remote base radio frequency transmitter and receiver adapted to be positioned in a remote location such as a weigh station, a fuel station, or a toll booth and which is then connected to a remote data communications terminal positioned to communicate to a communications network such as the Internet according to a seventeenth embodiment of the present invention;

FIG. 29 is a schematic view of a system for data communications between portions of a vehicle and a communications network using an infrared link and to a remote data terminal through the communications network according to a fifteenth embodiment of the present invention;

FIG. 30 is a schematic view of a system for data communications between a vehicle and a remote data terminal or communications network using an infrared link and then to remote data terminal through the communications network according to a sixteenth embodiment of the present invention;

FIG. 31 is a schematic view of an apparatus for data communications having a mobile infrared transmitter and receiver mounted on a truck or automobile and a remote base infrared transmitter and receiver adapted to be positioned in a remote location such as a weigh station, a fuel station, or a toll booth and which is then connected to a remote data communications terminal positioned to communicate to a communications network such as the Internet according to a seventeenth embodiment of the present invention;

FIG. 32 is a schematic view of a system for data communications to a remote data terminal using a communica-

tion network module mounted to a vehicle according to an eighteenth embodiment of the present invention;

FIG. 33 is a schematic view of a system for data communications between a vehicle and a communications network using an infrared link where the communications network is located at a weigh station having a power line carrier interface and a link to a communications network through a network module such as an Internet chip according to a nineteenth embodiment of the present invention;

FIG. 34 is a schematic view of a system for data communications between a vehicle and a remote communications network using an infrared link where the communications network is located in a weight station and the communications network has a power line carrier interface to a remote data communications terminal according to a twentieth embodiment of the present invention;

FIG. 35 is a schematic view of an apparatus for data communications to be mounted to a vehicle having a communications protocol interface for a vehicle, a communications protocol for transmitting to a remote data communications terminal or communications network, and for communicating to a remote communications network such as the Internet according to a twenty-first embodiment of the present invention; and

FIG. 36 is a schematic view of a system for data communications between a vehicle having a power line carrier communication link and having mounted thereto communication to a remote data communications terminal using either an infrared or radio frequency link in communication with the power line carrier communication link, to a communications network using a communications network module such as an Internet connected to the power line carrier communication link, to a cellular communications link having a cellular communications module in communication with the power line carrier communications link, and a positioning system data communications network in communication with the power line carrier communications link according to a twenty-second embodiment of the present invention.

DETAILED DESCRIPTION

The present invention will now be described more fully hereinafter with reference to the accompanying drawings, in which preferred embodiments of the invention are shown. This invention may, however, be embodied in many different forms and should not be construed as limited to the illustrated embodiments set forth herein. Rather, these illustrated embodiments are provided so that this disclosure will be thorough and complete, and will fully convey the scope of the invention to those skilled in the art. Like numbers refer to like elements throughout, and prime and double prime notation are used to indicate similar elements in alternative embodiments.

FIGS. 1-36 illustrate various embodiments of system, apparatus 30 and methods for data communication between a vehicle 20 and a remote data communication terminal, between portions of vehicle and other portions of vehicle, between two or more vehicles, and between a vehicle and a communications network according to the present invention. FIGS. 1-3 illustrate an apparatus 30 for data communications associated with a vehicle 20, such as a tractor/trailer combination or tractor/trailer truck of a heavy duty vehicle (s), according to a first embodiment of the present invention. As understood by those skilled in the art, the tractor/trailer combination preferably includes a tractor 21 connected to a trailer 25 for pulling the trailer 25. The tractor 21 and trailer 25 include respective frames and coupling means or cou-

plers for coupling the trailer 25 to the tractor 21. In addition, the tractor 21 includes an engine, such as a diesel engine or other motor, for moving the tractor 21 to thereby pull the trailer 25. Although the present invention is particularly advantageous to heavy duty vehicles, it will also be understood by those skilled in the art that other types of vehicles, such as a recreational vehicle, agricultural tractors or other heavy duty vehicles used in association with agricultural uses, automobiles, e.g., sedans, sports cars, luxury cars, race cars, train cars, pick-up trucks, sports recreations vehicles, and boats can also be used according to the present invention.

The data communications apparatus 30 preferably includes at least one electronic subsystem 40 associated with the vehicle 20. The at least one electronic subsystem 40, for example, can include an anti-locking brake system ("ABS") 41 connected to the vehicle 20. The tractor/trailer combination or other vehicle, however, preferably includes a plurality of electronic subsystems associated with tractor 21 and/or trailer 25. The electronic subsystems 40 preferably produce data or includes some type of signal generating means, e.g., preferably provided by a signal generator 42. Some examples of these electronic subsystems 40 and features which may be controlled and/or monitored by the apparatus of the present invention are illustrated for a tractor/trailer combination in Table I and for an agricultural tractor in Table II below:

TABLE I

TRACTOR	TRAILER
Mirror Tracking	Reefer Temperatures
Mirror with Trailer Display	Reefer Pressures
Controls for Reefer (Engine)	Trailer Identification
Controls for Trailer Slide	Blind Spot Warning
Axle	Cargo Information
Controls for Landing Gear	Smoke/Fire Detection
Active Faring	Overfill (Tanker)
Recorder for Trailer Functions	Cargo Shift
Satellite for Trailer Functions	Weight Detection
Brake System Information	Anti Lock Failure
Brake By Wire	Brake By Wire
Climate Controls for Reefer	Backup Lamps
Fuel Levels	Suspension Control
Oil Levels	Sliding Axle Control
Engine Temperature	Liftable Tailgate
Battery Voltage Levels	Time Pressure Monitor
Heating, Ventilation and Air Conditioning Functions	Lamp Outage Monitor
Transmission System Functions	Stop Lamp Saver (with Doubles and Triples)
Lighting System Functions	Water in Air Reservoir
Vehicle Speed	Liftable Landing Gear
Engine Speed	Brake Temperature
Mirror with Trailer Display	Emergency Line Pressure Detection
Trailer Identification	Vehicle Identification
Trailer Brake Temperature	Blind Spot Warning
Trailer Axle Temperatures	Cargo Information
Trailer Security	Time Pressure Warning
Weight Broadcast	Smoke Detector
Trailer Voltage Status	Roll Over Protection
GPS (Satellite Control to Implement)	Active Conspicuity (Lighting)
Vehicle Identification	Active Tire Pressure
	Backup Alarm
	Inventory Data Collection
	Security Warning
	Trailer Engine Start
	Trailer Engine Monitor
	Tractor/Changing from Reefer
	Trailer Dome Lamps
	Rear Door Lift (Motorized)
	Rear Door Status

TABLE II

TRACTOR	IMPLEMENT
Vehicle Speed Optimization	Sprayer Pressure
Engine Speed Optimization	Speed Planning Rates
Implement Display	Depth Position
GPS (Satellite Control to Implement)	Hydraulic Controls
	Speed Counting
	Moisture Sensing

The data communications apparatus **30** also preferably includes a plurality of electrical conductors **38**, e.g., preferably provided by twisted pair wiring as understood by those skilled in the art, or other conductor configurations such as single wire, which are preferably connected to the plurality of electronic subsystems **40** and associated with the vehicle **20**. The plurality of electrical conductors **38** preferably provide one or more data communications channels or paths for data communications with the electronic subsystems **40**, as well as a controller **45** as described further below herein. For example, data can be directly communicated, e.g., on/off, status, threshold levels, RS-232, or RS-485 protocols, through the conductors or power line carrier (“PLC”) communication protocols such as Spread Spectrum, e.g., CEBus, X-10, such as offered by Cogency Semiconductor, Inc. of Canada or Intellon Corp. of Ocala, Fla. or other protocols along the conductors as understood by those skilled in the art.

As perhaps best illustrated in FIGS. **5** and **11**, the data communications apparatus **30** preferably also has vehicle data communications protocol converting means **33**, **33'**, e.g., preferably provided by a vehicle data communications protocol converter as illustrated by first and second data communications protocol converters **37**, **39**, **37'**, **39'** and a first signal booster **36**, **36'**, connected to the plurality of electrical conductors **38**, **38'** for converting a first data communications protocol associated with data communications along the plurality of electrical conductors **38**, **38'** to a second data communications protocol. As understood by those skilled in the art, the first data communications protocol is preferably according to SAE J1708, but also could be according to SAE J1939, SAE J1587, RS-485, or power line carrier (“PLC”) protocols as well. In other words, the first data communications protocol is preferably an existing data communications protocol associated with a vehicle **20**. The first data communications protocol converter **37** is preferably an RS-485 transceiver, as understood by those skilled in the art, which transmits and receives data communications according to the J1708 or other protocols to the plurality of conductors **38** and transmits and receives data communications according to the RS-485 protocol to the second data communications protocol converter **39** and vice-versa. Other data communication protocols such as global communications network, e.g., Internet, protocol can be used as well according to the present invention. A through-the-air data communications protocol, however, can be particularly advantageous so that a driver or passenger does not have to exit a vehicle, locate a cable, and connect it to a vehicle and yet can accomplish accurate and efficient data communications.

Additionally, the vehicle data communications protocol converting means **33** can convert the first data communications protocol, e.g., SAE J1708, into a third data communications protocol, e.g., RS-485, and then convert the third data communications protocol, e.g., RS-485, into yet the second data communications protocol, e.g., IrDa or other

infrared or RF data communications protocol such as Bluetooth, 802.11 Standard, or other RF data communications protocols, or a designated communications network protocol such as the Internet, which is used to transmit data through-the-air to a remote data communications terminal **60**, **60'** (see FIGS. **5** and **11**). The second data communications protocol converter **39** preferably is a combination of a microprocessor or other microcontroller connected to the RS-485 transceiver which transmits and receives logic level signals and an infrared IrDA compliant integrated circuit, such as provided by Hewlett Packard or Rohm as understood by those skilled in the art, connected to the microprocessor which transmits and receives the logic level signals, a Bluetooth, 802.11 Standard or other RF data communications protocol compliant integrated circuit, or a designated communication network, such as the Internet, compliant integrated circuit, such as provided by Zilog, e.g., the eZ80 Webserver, as understood by those skilled in the art.

When transmitting from the vehicle **20**, the IrDA compliant integrated circuit receives logic levels from the microcontroller and converts the logic levels to IrDA data communications protocol based upon timed infrared pulse signals of a predetermined position, pulse widths, and/or duration depending on the desired baud or bit rate of data communications. The IrDA integrated circuit also receives an infrared data communications protocol and transmits logic levels when receiving data communications from a remote data communications terminal **60**. The IrDA integrated circuit can include a built-in infrared transceiver **35**, e.g., an infrared light emitting diode and an infrared photodetector or photodiode. At least the infrared light emitter or light emitting diode, however, is preferably not built into the IrDA integrated circuit because the vehicle data communications protocol converting means **33** also preferably includes the first signal booster **36**. If infrared is used, for example, an infrared transceiver or emitter/detector pair such as provided by Sharp Corp., namely the Opto-Electronic Devices Division such as Model No. GP2W0004YP.

If infrared is one or more of the first, second, or third data communications protocol as described herein, then preferably one or more coverings to effect shading and/or filtering of a receiver or detector portion of an infrared transceiver is preferably used to reduce any impact or interference from station, room or other lights which may emit infrared or near infrared wavelengths of light and to increase the ease and clarity of recognition of a data communications signal. The covering, for example, can be a hood or cup formed closely adjacent at least a portion of the receiver or detector other than the standard encapsulation of the receiver or detector so that the potential interfering light is shaded out or reduced so that it is not directed toward the receiver as much. In addition to or as an alternative, different filtering techniques can be used as well such as covering the receiver with a lens or other filter which assists in enhancing data communication signal recognition, especially in environments which may otherwise cause signal recognition to be somewhat difficult. For example, an infrared receiver or detector can have a standard encapsulation and then according to the present invention a lens or protective covering can be used to overlie or surround the encapsulated receiver or detector. Then still, a hood, cup, or other protective and shading member can be used to further shade or cover the lens to yet further reduce interference from room, station, or other lights or to enhance signal recognition.

The second data communications protocol is preferably one of either an infrared data communications protocol, an

RF data communications protocol, or a designated communications network protocol such as the Internet. In other words, the second data communications protocol is preferably a through-the-air type of data communications protocol which does not require equipment to be coupled to the vehicle **20** when obtaining data therefrom or monitoring vehicle operational conditions. If the data communications is according to an RF data communications protocol as illustrated in FIG. **11**, then the second data communication protocol converter **39'** preferably includes an RF data communications integrated circuit or analog circuit as understood by those skilled in the art which receives and transmits logic levels to a microprocessor or microcontroller and transmits and receives RF data communications according to predetermined RF data communications protocol, e.g., a simple modulation scheme or a more complex protocol such as CEBus as understood by those skilled in the art.

Additionally, particularly on the transmit portion of the vehicle data communications converting means **33**, the converting means **33** also preferably includes a signal booster **36**, e.g., preferably provided by amplification circuitry and/or power boosting circuitry, which advantageously boosts the transmit signal to thereby increase the successful transmit range of the associated transmit portion of the transceiver **35**.

An infrared data communications protocol, such as IrDA as understood by those skilled in the art, can be particularly advantageous in association with vehicles for numerous reasons. For example, dirt, dust, grime, corrosive atmospheres, vibration, rough handling, or other obstacles can often be readily overcome with appropriate design of the driving and receiving electronics. Also, infrared data communications is immune from electro-magnetic interference ("EMI") which, as understood by those skilled in the art, can impact other types of data communications media. Further, infrared data communications would not interfere with other type of through-the-air data communications channels such as RF data communications.

If an RF data communications protocol is used, as understood by those skilled in the art, then the RF data communications protocol preferably has designated bandwidths or other techniques used to reduce noise.

As illustrated in FIGS. **1-2** and **4**, a connector **50** is preferably connected to the plurality of electrical conductors **38**. The connector **50** can also be connected to one or more of the electronic subsystems **40**, e.g., an ABS system, preferably through the electrical conductors **38**. For example, the connector **50** can be a six-pin Deutch connector or other well known connector associated with trucks or other vehicles (see FIG. **4**). The connector **50**, in a first embodiment, also can be advantageously positioned in the cab **23** of the tractor **21** of the truck (see FIGS. **2-3**). This location, for example, is a secure position for a transceiver **35**, as described further below herein, because the cab **23** can be locked and a security alarm system or other security system can be associated with the cab **23**. Additionally, the cab **23** provides a convenient position for the driver, government officials, or others involved in the related industry to provide access to operational conditions of the vehicle **20**. This further takes advantage of existing positions of vehicle connectors to tap into or access the plurality of electrical conductors **38** which provide data or information to the cab of the tractor without requiring extensive rewiring, retrofitting, or adding expensive equipment to the vehicle **20**.

As perhaps best illustrated in FIGS. **8-10**, in a second embodiment of the connector **50'**, for example, the connector

50' can be positioned more closely in association with one of the electronic subsystems **40** such as the ABS system of the trailer **25** of the truck. The second embodiment also illustrates a connector **50'** known to those in the vehicle art, and namely the trucking industry. This connector **50'**, however, is advantageously modified by adding a transceiver housing **34** and a transceiver **35** as described further below herein. In each of the first and second embodiments, the connector **50, 50'** preferably includes a plurality of pins **55** having a predetermined pin configuration. The connector **50, 50'** also preferably has one of either a generally cylindrical or a generally rectangular shape.

The connector **50, 50'** also preferably has first and second mating connector portions **51, 52, 51', 52'** which are joined together by a frictional fit so that the plurality of pins **55** are matingly received into a corresponding plurality of contact elements **56**. As understood by those skilled in the art, the connector **50, 50'** can also have some type of connector aligning means associated therewith for readily aligning the first and second mating connector portions **51, 52, 51', 52'**.

A transceiver housing **34** is preferably detachably connected to the connector **50, 50'**. The transceiver housing **34, 34'** also preferably includes a translucent cover member **31** for transmitting the second data communications protocol therethrough. In a first embodiment of the transceiver housing **34**, the transceiver housing **34** can either include the second mating connector portion **52** being formed as a portion of or integrally as a single piece therewith, or the second mating connector portion **52** can define the transceiver housing **34**. The transceiver housing **34** in this embodiment likewise preferably has one of either a cylindrical or a rectangular shape. The transceiver housing **34** preferably includes or has integrally formed as one piece therewith an optically translucent cover member **31** for transmitting and receiving infrared or RF data communications therethrough to the remote data communications terminal **60**. Advantageously, because the transceiver housing **34** forms a portion of or readily attaches to a standard vehicle connector, e.g., the first mating connector portion **51**, the data communications apparatus **30** is readily adapted to existing vehicle data communication technology and does not require either extensive retrofitting or extensive and expensive additions to existing vehicle data communication technology.

As perhaps best illustrated in FIGS. **6-7**, in a second embodiment of the transceiver housing **34'**, the transceiver housing **34'** can advantageously be a vehicle light housing mounted to the vehicle **20** for housing a vehicle light. The vehicle light housing, for example, can advantageously be a side-marker light housing mounted to the trailer **25** of a truck so that a third party would not readily recognize that the truck is equipped with the data communications apparatus **30**.

A transceiver **35** is preferably positioned within the transceiver housing **34, 34'** and connected to the vehicle data communications protocol converting means **33** for transmitting the second data communications protocol from the vehicle **20** and receiving the data communications protocol from a remote data communications terminal **60**. For infrared data communications, for example, the transceiver **35** (see also FIG. **4**) preferably includes a plurality of infrared light emitter or light emitting diodes, a plurality of infrared photodiodes, and associated drive and amplification circuitry as understood by those skilled in the art.

As also understood by those skilled in the art, the transceiver **35** is preferably only a physical layer signal process-

ing transceiver, e.g., infrared or radio frequency, and preferably includes a combination transmitter and receiver which collects data or information from the various subsystems and communicates the data to one or more remote data communications terminals **60**. It will be understood by those skilled in the art that the apparatus is not limited to communication by a physical layer signal processing transceiver, but that other communication protocol techniques can be used as well. The transceiver **35** is preferably a first transceiver **35**, and the one or more remote data communication terminals **60** preferably each include a second transceiver **65**, **65'** for transmitting the second data communications protocol to the first transceiver **35** and receiving the second data communications protocol from the first transceiver **35**. The second transceiver **65**, **65'** is preferably similar to the first transceiver **35** as described herein above and accordingly for brevity will not be repeated herein.

The first and second transceivers **35**, **35'**, **65**, **65'** also each include a signal processing physical layer. Advantageously, the second data communications protocol only uses the physical layer of the first and second transceivers **35**, **65** for signal processing and not a data link layer ("DLL") as understood by those skilled in the art. By only using the physical layer for signal processing, the data communications and coding or modulation schemes for the communications is greatly simplified and the data conversion from one data communications protocol to another data communications protocol is also simplified.

The remote data communications terminal **60** is preferably a computer, e.g., provided by a portable laptop or handheld computer, or other portable or substantially stationary remote data collection stations as understood by those skilled in the art. The remote data communications terminal, for example, can be positioned at one or more locations where a vehicle owner, another vehicle, security system, or other data collection point such as an entrance to a shop, station, or fuel island desires to collect data. The second transceiver does not need to be near or adjacent the computer or other terminal itself as long as the second transceiver is positioned to receive the second data communication protocol from the vehicle. The remote data communications terminal **60** also includes remote data communications protocol converting means **63**, e.g., preferably provided by a remote data communication protocol converter as illustrated by the third data communications protocol converter **69** and the second signal booster **66**, for converting the second data communications protocol received by the remote data communications terminal to a third data communications protocol associated with the computer. The third data communications protocol, for example, can be RS-232, RS-422, RS-423 or other data communications protocol, as understood by those skilled in the art. If two conversions occur in the vehicle data converter **33**, e.g., RS-485 to RS-232 and RS-232 to IrDA or RF, then the third data communications protocol would actually be yet a fourth data communications protocol as sequentially illustrated in FIGS. **5** and **10**. The remote data communications protocol converting means **63**, e.g., a remote data communications protocol converter, also preferably includes data signal boosting means, e.g., a second signal booster **66** similar to the first signal booster **36** as described above herein, for boosting the range of the signal between the remote data communications terminal **60** and the first transceiver **35** of the data communications apparatus **30** to thereby increase the effective range of transmission for which the apparatus **30** is anticipated to be used. The remote

data communications terminal also preferably includes a predetermined data communications protocol transceiver **61**, **61'**, e.g., preferably provided by an RS-232 transceiver or other type of transceiver as understood by those skilled in the art, as a data communications interface to the personal computer **68** or other data terminal.

The data communications apparatus **30** according to the present invention preferably also includes at least one controller **45** connected to the at least one electronic subsystem **40** and the plurality of electrical connectors **38** for controlling data communications along the plurality of electrical conductors **38**, e.g., to and from the electronic subsystem(s) **40**. As understood by those skilled in the art, the controller **45** preferably includes a microprocessor or microcomputer operating under stored program control to perform various functions related to the monitoring and control of various electronic subsystems on either or both of the tractor **21** and trailer **25** or to the remote data communications terminals **60**.

As set forth previously above, each electronic subsystem **40** to be controlled and/or monitored preferably includes signal generating means, e.g., preferably provided by a signal generator, connected to the controller **45** for generating a signal related to the operation of the vehicle **20**. The controller **45**, for example, produces or outputs a number of digital or analog output controls in the form of relay contact closures or other signals to either the subsystems or to the transceiver **35**. The controller **45**, for example, can also be an ABS controller which actuates control valves on the trailer **25** to control the brake chambers of the brakes associated with the trailer **25**.

Alternatively, as illustrated in FIGS. **12-36**, the apparatus also provides communication between vehicles, from portions of a vehicle, e.g., within nodes, and communication to other communication networks such as in a building or a global communications network. In these embodiments, a vehicle, such as a tractor-trailer combination which is actually two vehicles, e.g., a tractor **135** and a trailer **140**, communicates with another vehicle, namely a security vehicle such as a law enforcement or police vehicle **160** (see FIGS. **12-13** and FIGS. **14-15**). In these embodiments, for example, a first infrared or RF transceiver preferably is advantageously mounted to a trailer **140** (or a tractor **135**) for communication with the security vehicle **160** using wireless data communications. The security vehicle **160** then has a second infrared or RF transceiver mounted thereto for wireless data communications between the vehicles.

In this manner, the security vehicle **160**, for example, can gather information such as vehicle identification data, secure information such as vehicle and/or cargo weight, driver registration information, cargo contents, or operation characteristics of the vehicle without the need to stop the vehicle. This, in turn, provides an added level of security to highway or other roadway travel, especially in the event of a stolen, unauthorized, hijacked, or other potentially dangerous or hazardous situation. In these embodiments, the security vehicle **160** is preferably equipped with a remote data communications terminal or other data collection, gathering, or transmitting device such as mounted to a side panel of a door, positioned in a dashboard region of the security vehicle **160**, positioned along one of the windows of the security vehicle **160**, or positioned in association with the trunk or engine compartments of the security vehicle **160**. The apparatus **130** in these embodiments is preferably substantially similar to the one described in the above embodiments and can be positioned in a light marker housing or other housing for communication between vehicles.

In addition, such as shown in FIGS. 16–19, the apparatus 130' also includes communications between a tractor and a trailer as two separate vehicles or as a combination of one vehicle. In these embodiments, a first transceiver preferably is mounted to the rearward portions of the tractor and a second transceiver preferably is mounted to the forward portions of the trailer so that the distance between the transceivers is minimized and be readily ascertainable. In this manner, a driver can monitor the contents of the trailer without having to leave his seat to physically inspect the trailer. The driver can also be made aware of various trailer conditions. In turn, the tractor can have a remote data terminal positioned therein so that the trailer has the first data communications protocol in a network within the trailer, the first data communications protocol is converted to the second data communications protocol for a through the air wireless communication between the trailer and the tractor, the tractor receives the second data communications protocol, and then converts it to a third data communications protocol for a remote terminal such as positioned in the cab of the tractor for displaying, viewing, and interfacing with the driver or passenger.

Also, for example, a high speed and a low speed data communications protocol such as PLC can coexist on the same power lines. Also, two or more low speed data communications protocols, such as CEBus and PowerBus, can coexist on the same lines if desired as a PLC communications. At low speed, although there may be a certain amount of conflict between the communication protocols, the communication protocols preferably share the available bandwidth where coexistence is desired or occurs. Adding PowerBus nodes to a CEBus network will reduce the throughput of the CEBus network, but should not result in communication failures using either technology. Although lower speeds, e.g., less than 100 kilobits per second (Kbps), may be desired due to lower cost and increased reliability for certain types of communication, but higher speeds, e.g., greater than 100 Kbps can be used as well according to the present invention. Higher speeds, for example, are particular applicable to shared broadband access, low-latency audio and video streaming, and high reliability using high speed PLC integrated circuit or chip sets such as provided by Cogency Semiconductor, Inc. of Canada or Intellon Corp. of Ocala, Fla. More preferably, these higher speeds are even higher than 10 Megabits per second (Mbps). The higher speed PLC, for example, can use orthogonal frequency-division multiplexing signal processing over power lines as understood by those skilled in the art and can be used as an alternative to lower speed PLC or, more preferably, in conjunction with lower speed PLC. When used in conjunction with the lower speed PLC, the higher speed PLC is preferably positioned in the same controller, but two separate controllers can be used as well as understood by those skilled in the art.

As illustrated in FIGS. 1–36, the present invention also includes methods of data communications associated with a vehicle 20. The method preferably includes providing a plurality of electrical conductors 38 associated with a vehicle 20 and converting a first vehicle data communications protocol associated with data communications along the plurality of electrical conductors 38 to a second data communications protocol. The method also includes transmitting the second data communications protocol from the vehicle 20 to a remote data communications terminal 60. The first data communications protocol is preferably either SAE J1708 or SAE J1939. The second data communications protocol, on the other hand, is preferably one of either an

infrared data communications protocol or an RF data communications protocol.

The method can also include receiving the second data communications protocol from the remote data communications terminal 60, controlling data communications along the plurality of electrical conductors 38, and generating a signal related to the operation of the vehicle 20. For example, the remote data communications terminal 60 can be a computer, and the method can include remotely converting the second data communications protocol received by the remote data communications terminal 60 to a third data communications protocol associated with the computer.

The method additionally can include positioning a connector 50 so as to be connected in series with the plurality of electrical conductors 38, positioning a transceiver 35 in association with the connector 50, detachably connecting a transceiver housing 34 to the connector 50, and positioning the transceiver 35 within the transceiver housing 34. The transceiver housing 34 preferably includes a translucent cover member 31 for transmitting and receiving the second data communications protocol therethrough.

The method can still further include providing at least one electronic subsystem 40 associated with the heavy duty vehicle 20 and connected to the plurality of electrical conductors 38 related to operation of the vehicle 20. The transceiver 35 is preferably a first transceiver, and the remote data communication terminal 60 includes a second transceiver 65. The method also includes transmitting the second data communications protocol to the first transceiver 35 and receiving the second data communications protocol from the first transceiver 35. The first and second transceivers 35, 65 each preferably include a physical layer, and the method further includes transmitting and receiving the second data communications protocol only using the physical layer of the first and second transceivers 35, 65.

In the drawings and specification, there have been disclosed a typical preferred embodiment of the invention, and although specific terms are employed, the terms are used in a descriptive sense only and not for purposes of limitation. The invention has been described in considerable detail with specific reference to these illustrated embodiments. It will be apparent, however, that various modifications and changes can be made within the spirit and scope of the invention as described in the foregoing specification and as defined in the appended claims.

That which is claimed:

1. A vehicle comprising:

a cab; and

a data communications apparatus connected to said cab for communicating data to and from said cab, said data communications apparatus comprising:

at least one electronic subsystem associated with the vehicle and related to the operation of the vehicle;

a plurality of electrical conductors connected to the at least one electronic subsystem and associated with the vehicle;

a connector connected in series with said plurality of electrical conductors and positioned in said cab;

vehicle data communications protocol converting means connected to said plurality of electrical conductors for converting a first data communications protocol associated with data communications along the plurality of electrical conductors to a second data communications protocol;

a first transceiver associated with said connector and connected to said vehicle data communications pro-

protocol converting means for transmitting and receiving the second data communications protocol; and a remote data communications terminal including a second transceiver for transmitting the second data communications protocol to said first transceiver and receiving the second data communications protocol from said first transceiver.

2. A vehicle as defined in claim 1, further comprising a transceiver housing detachably connected to said connector and positioned within the cab, and wherein said first transceiver is positioned within said transceiver housing.

3. A vehicle as defined in claim 2, wherein the second data communications protocol comprises one of either an infrared data communications protocol, an RF data communications protocol, a global communications network protocol, or a power line carrier protocol, and wherein said transceiver housing includes a translucent cover member for optically transmitting the data communications protocol there-through.

4. A vehicle as defined in claim 3, wherein said first and second transceivers each include a signal processing physical layer, and wherein the second data communications protocol only uses the physical layer of the first and second transceivers for signal processing.

5. A vehicle as defined in claim 4, wherein said connector includes a plurality of pins having a predetermined pin configuration, and wherein said connector has one of either a generally cylindrical or a generally rectangular shape.

6. A vehicle as defined in claim 5, wherein said connector comprises a six-pin connector having first and second connector portions thereof, and wherein the second connector portion defines said transceiver housing.

7. A vehicle as defined in claim 5, wherein the first data communications protocol comprises one of the data communications protocols specified by either SAE J1708, SAE J1939, or IEEE 802.11 Standard.

8. A vehicle as defined in claim 7, wherein said at least one electronic subsystem comprises an anti-locking brake system, and wherein said connector is also connected to said anti-locking brake system.

9. A vehicle as defined in claim 8, further comprising a controller connected to said at least one electronic subsystem and said plurality of electrical connectors for controlling data communications along said plurality of electrical conductors and signal generating means connected to said controller for generating a signal related to the operation of the vehicle.

10. A vehicle as defined in claim 9, wherein said remote data communications terminal comprises a computer and further includes remote data communications protocol converting means for converting the second data communications protocol received by said remote data communications terminal to a third data communications protocol associated with said computer.

11. An apparatus for data communications associated with a vehicle, the apparatus comprising:

a plurality of electrical conductors associated with the vehicle;

a vehicle data communications protocol converter connected to said plurality of electrical conductors to convert a first data communications protocol associated with data communications along the plurality of electrical conductors to a second data communications protocol; and

a transceiver connected to said vehicle data communications protocol converter to transmit the second data communications protocol from the vehicle and receive

the second data communications protocol from a remote data communications terminal.

12. An apparatus as defined in claim 11, further comprising a connector connected in series with said plurality of electrical conductors, and wherein said transceiver is associated with said connector.

13. An apparatus as defined in claim 12, further comprising a transceiver housing detachably connected to said connector, and wherein said transceiver is positioned within said transceiver housing.

14. An apparatus as defined in claim 13, wherein the second data communications protocol comprises one of either an infrared data communications protocol, an RF data communications protocol, a global communication network protocol, or a power line carrier communications protocol, and wherein said transceiver housing includes a translucent cover member for transmitting the second data communications protocol therethrough.

15. An apparatus as defined in claim 14, wherein said connector includes a plurality of pins having a predetermined pin configuration, and wherein said connector has one of either a generally cylindrical or a generally rectangular shape.

16. An apparatus as defined in claim 15, wherein said connector comprises a six-pin connector having first and second connector portions thereof, and wherein the second connector portion defines said transceiver housing.

17. An apparatus as defined in claim 12, further comprising at least one electronic subsystem associated with the heavy duty vehicle and related to operation of the vehicle, the at least one electronic subsystem including an anti-locking brake system connected to the vehicle, and wherein said connector is also connected to said anti-locking brake system.

18. An apparatus as defined in claim 17, wherein said transceiver comprises a first transceiver, and wherein the remote data communication terminal includes a second transceiver for transmitting the second data communications protocol to said first transceiver and receiving the second data communications protocol from said first transceiver.

19. An apparatus as defined in claim 18, wherein the first and second transceivers each include a signal processing physical layer, and wherein the second data communications protocol only uses the physical layer of the first and second transceivers for signal processing.

20. An apparatus as defined in claim 19, wherein said remote data communications terminal comprises a computer and further includes remote data communications protocol converting means for converting the second data communications protocol received by said remote data communications terminal to a third data communications protocol associated with said computer.

21. An apparatus as defined in claim 20, further comprising a controller connected to said at least one electronic subsystem and said plurality of electrical connectors for controlling data communications along said plurality of electrical conductors and signal generating means connected to said controller for generating a signal related to the operation of the vehicle.

22. An apparatus as defined in claim 11, further comprising a vehicle light housing connected to the heavy duty vehicle for housing a vehicle light, and wherein said transceiver is positioned in said vehicle light housing.

23. An apparatus as defined in claim 22, wherein said vehicle light housing comprises a side-marker light housing.

24. An apparatus as defined in claim 23, wherein said transceiver comprises a first transceiver, and wherein the

remote data communication terminal includes a second transceiver for transmitting the second data communications protocol to said first transceiver and receiving the second data communications protocol from said first transceiver.

25. An apparatus as defined in claim 24, wherein the first and second transceivers each include a physical layer, and wherein the second data communications protocol only uses the physical layer of the first and second transceivers.

26. An apparatus as defined in claim 22, wherein the first data communications protocol comprises one of the data communications protocols specified by either SAE J1708, SAE J1939, or IEEE 802.11 Standard.

27. An apparatus for data communications associated with a vehicle, the apparatus comprising:

- at least one electronic subsystem associated with the vehicle;
- a plurality of electrical conductors connected to the at least one electronic subsystem and associated with the vehicle;
- a vehicle data communications protocol converter connected to said plurality of electrical conductors to convert a first data communications protocol associated with data communications along the plurality of electrical conductors to a second data communications protocol;
- a connector connected to said plurality of electrical conductors;
- a transceiver housing connected to said connector; and a transceiver positioned within said transceiver housing connected to said vehicle data communications protocol converter to transmit the second data communications protocol from the vehicle and receive the data communications protocol from a remote data communications terminal.

28. An apparatus as defined in claim 27, wherein the second data communications protocol comprises one of either an infrared data communications protocol, an RF data communications protocol, a global communications network protocol, or a power line carrier communications protocol, and wherein said transceiver housing includes a translucent cover member for transmitting the second data communications protocol therethrough.

29. An apparatus as defined in claim 28, wherein the at least one electronic subsystem includes an antilocking brake system connected to the heavy duty vehicle, and wherein said connector is also connected to said anti-locking brake system.

30. An apparatus as defined in claim 28, wherein said connector includes a plurality of pins having a predetermined pin configuration, and wherein said connector has one of either a generally cylindrical or a generally rectangular shape.

31. An apparatus as defined in claim 30, wherein said connector comprises a six-pin connector having first and second connector portions thereof, and wherein the second connector portion defines said transceiver housing.

32. An apparatus as defined in claim 28, wherein said transceiver comprises a first transceiver, and wherein the remote data communication terminal includes a second transceiver for transmitting the second data communications protocol to said first transceiver and receiving the second data communications protocol from said first transceiver.

33. An apparatus as defined in claim 32, wherein the first and second transceivers each include a signal processing physical layer, and wherein the second data communications protocol only uses the physical layer of the first and second transceivers for signal processing.

34. An apparatus as defined in claim 33, wherein said transceiver housing comprises a vehicle light housing connected to said connector for housing a vehicle light, and wherein said transceiver is positioned in said vehicle light housing.

35. An apparatus as defined in claim 34, wherein said vehicle light housing comprises a side-marker light housing.

36. An apparatus as defined in claim 33, wherein said remote data communications terminal comprises a computer and further includes remote data communications protocol converting means for converting the second data communications protocol received by said remote data communications terminal to a third data communications protocol associated with said computer.

37. An apparatus as defined in claim 36, further comprising a controller connected to said at least one electronic subsystem and said plurality of electrical connectors for controlling data communications along said plurality of electrical conductors and signal generating means connected to said controller for generating a signal related to the operation of the vehicle.

38. An apparatus as defined in claim 37, wherein the first data communications protocol comprises one of the data communications protocols specified by either SAE J1708, SAE J1939, or IEEE 802.11 Standard.

39. An apparatus for data communications associated with a vehicle, the apparatus comprising:

- a transceiver housing adapted to be detachably connected to a connector mounted to a vehicle, the connector being connected to a plurality of electrical conductors associated with the vehicle;
- a vehicle data communications protocol converter positioned in said housing to convert a first data communications protocol associated with data communications along the plurality of electrical conductors to a second data communications protocol; and a transceiver positioned within said transceiver housing and connected to said vehicle data communications protocol converter to transmit the second data communications protocol from the vehicle and receive the data communications protocol from a remote data communications terminal.

40. An apparatus as defined in claim 39, wherein the second data communications protocol comprises one of either an infrared data communications protocol, an RF data communications protocol, a global communications network protocol, or a power line carrier communications protocol, and wherein said transceiver housing includes a translucent cover member for transmitting the second data communications protocol therethrough.

41. An apparatus as defined in claim 40, wherein the connector of the vehicle is positioned in a cab of the vehicle.

42. An apparatus as defined in claim 40, wherein the connector of the vehicle is positioned in associated with an anti-locking braking system of the trailer of a truck.

43. An apparatus as defined in claim 40, wherein the connector has first and second mating connector portions, and wherein said transceiver housing includes the second mating connector portion for connecting to the connector of the vehicle.

44. An apparatus as defined in claim 43, wherein said transceiver housing has one of either a generally cylindrical or a generally rectangular shape.

45. An apparatus as defined in claim 43, wherein said transceiver includes a signal processing physical layer, and wherein the second data communications protocol only uses the physical layer of said transceiver for signal processing.

46. An apparatus as defined in claim 40, wherein the first communications protocol comprises one of the data communications protocols specified by either SAE J1708, SAE J1939, or IEEE 802.11 Standard.

47. An apparatus for data communications associated with a vehicle, the apparatus comprising:

- a transceiver housing mounted to a vehicle;
- a vehicle data communications protocol converter positioned in said housing to convert a first data communications protocol associated with data communications along a plurality of electrical conductors to a second data communications protocol; and

a transceiver positioned within said transceiver housing and connected to said vehicle data communications protocol converter to transmit the second data communications protocol from the vehicle and receive the data communications protocol from a remote data communications terminal.

48. An apparatus as defined in claim 47, wherein said transceiver housing comprises a vehicle light housing mounted to the vehicle, and wherein said transceiver and said vehicle data converter are both positioned in said vehicle light housing.

49. An apparatus as defined in claim 48, wherein said vehicle light housing comprises a side-marker light housing.

50. An apparatus as defined in claim 49, wherein the second data communications protocol comprises one of either an infrared data communications protocol, an RF data communications protocol, a global communications network protocol, or a power line carrier communication protocol, and wherein said side marker light housing includes a translucent cover member for transmitting the second data communications protocol therethrough.

51. An apparatus as defined in claim 50, wherein said side marker light housing of the vehicle is mounted to a trailer of a truck.

52. An apparatus as defined in claim 51, wherein said side marker light housing is also connected to an antilocking braking system of the trailer of the truck.

53. An apparatus as defined in claim 50, wherein said transceiver includes a signal processing physical layer, and wherein the second data communications protocol only uses the physical layer of said transceiver for signal processing.

54. An apparatus as defined in claim 53, wherein the first communications protocol comprises one of the data communications protocols specified by either SAE J1708, SAE J1939, or IEEE 802.11 Standard.

55. A method of data communications associated with a vehicle, the method comprising the steps of: providing a plurality of electrical conductors associated with a vehicle; converting a first vehicle data communications protocol associated with data communications along the plurality of electrical conductors to a second data communications protocol; and

transmitting the second data communications protocol from the vehicle to a remote data communications terminal.

56. A method as defined in claim 55, further comprising receiving the second data communications protocol from the remote data communications terminal.

57. A method as defined in claim 56, further comprising controlling data communications along the plurality of electrical conductors and generating a signal related to the operation of the vehicle.

58. A method as defined in claim 57, further comprising positioning a connector so as to be connected in series with the plurality of electrical conductors and positioning a transceiver in association with the connector.

59. A method as defined in claim 58, further comprising detachably connecting a transceiver housing to the connector and positioning the transceiver within the transceiver housing.

60. A method as defined in claim 59, wherein the second data communications protocol comprises one of either an infrared data communications protocol, an RF data communications protocol, a global communications network protocol, or a power line carrier communications protocol, and wherein the transceiver housing includes a translucent cover member for transmitting and receiving the second data communications protocol therethrough.

61. A method as defined in claim 60, further comprising providing at least one electronic subsystem associated with the vehicle and connected to the plurality of electrical conductors related to operation of the vehicle.

62. A method as defined in claim 61, wherein the transceiver comprises a first transceiver, and wherein the remote data communication terminal includes a second transceiver, the method further comprising transmitting the second data communications protocol to the first transceiver and receiving the second data communications protocol from the first transceiver.

63. A method as defined in claim 62, wherein the first and second transceivers each include a physical layer, and the method further comprising transmitting and receiving the second data communications protocol only using the physical layer of the first and second transceivers.

64. A method as defined in claim 63, wherein the remote data communications terminal comprises a computer, and the method further comprises remotely converting the second data communications protocol received by the remote data communications terminal to a third data communications protocol associated with the computer.

65. A method as defined in claim 64, wherein the first data communications protocol comprises one of the data communications protocols specified by either SAE J1708, SAE J1939, or IEEE 802.11 Standard.

* * * * *