

UNITED STATES DISTRICT COURT  
EASTERN DISTRICT OF MICHIGAN  
SOUTHERN DIVISION

CHOON'S DESIGN, LLC,

Plaintiff and Counter-Defendant,

v.

IDEA VILLAGE PRODUCTS CORP.,

Defendant and Counter-Claimant.

Case No. 2:13-cv-13568

Honorable Laurie J. Michelson

Magistrate Judge R. Steven Whalen

---

**OPINION AND ORDER CONSTRUING PATENT CLAIM TERMS**

---

For the past few years, looms that help link a number of small, colorful elastic bands to create bracelets, necklaces, and the like have been extremely popular, especially among school-aged children. Choon's Design Inc. ("Choon") introduced its highly-successful version of this product, the Rainbow Loom, in late 2011. It has since sold over five million of them. Choon says the Rainbow Loom's success spawned a number of unlawful imitations. In this case (the first of twelve Choon filed in this District), Choon accuses IdeaVillage Products Corporation, which sells a competing product called the Fun Loom, of infringing two of its utility patents: United States Patent No. 8,485,565 ("the '565 patent") and United States Patent No. 8,684,420 ("the '420 patent").

The parties dispute the meaning of the claims of these two patents. As with all patents, it is the claims that define the patent holder's exclusive territory: a competing product infringes a patent only if the device has every feature, or every "limitation," set out in one of the patent's claims. *SmithKline Diagnostics, Inc. v. Helena Labs. Corp.*, 859 F.2d 878, 889 (Fed. Cir. 1988). Choon seeks an interpretation, or "a construction," of the claims such that they cover the Fun

Loom, while IdeaVillage seeks constructions that narrow Choon’s exclusive territory such that the claims do not cover the Fun Loom.

The parties ask the Court to resolve their dispute about the scope of two claims of the ’565 patent and one claim of the ’420 patent by declaring the meaning of ten claim terms. Having been advised by extensive briefing, the case law, and a *Markman* hearing, the Court issues this opinion explaining its construction of certain claim terms in dispute. *See generally Markman v. Westview Instruments, Inc.*, 517 U.S. 370 (1996). In brief, the Court finds that claims 9 and 14 of the ’565 patent do not cover one-piece looms with “pin bars” that are integrated with the “base” while claim 3 of the ’420 patent does cover looms with “pins” that are integrated with the “base.” A list of the Court’s constructions appears at the end of this opinion.

## I.

### A.

There are two patents in suit: United States Patent No. 8,485,565 and United States Patent No. 8,684,420. The parties ask the Court to construe terms in claims 9 and 14 of the ’565 patent and terms in claim 3 of the ’420 patent. What follows is an overview of the two patents and these three claims.

#### 1.

The United States Patent and Trademark Office issued the ’565 patent on July 16, 2013. (Dkt. 150, Jt. Claim Constr. App’x Ex. 1, ’565 patent.) The patent “relates to a method and device for creating a linked wearable item from elastic bands.” (’565 patent col. 1, ll. 14–16.) At slightly greater specificity, the patent is directed toward creating wearable items from Brunnian links, which the patent defines as “a link formed from a closed loop doubled over itself to

capture another closed loop to form a chain.” (’565 patent col. 1, ll. 31–33.) A Brunnian link (20) is depicted below:

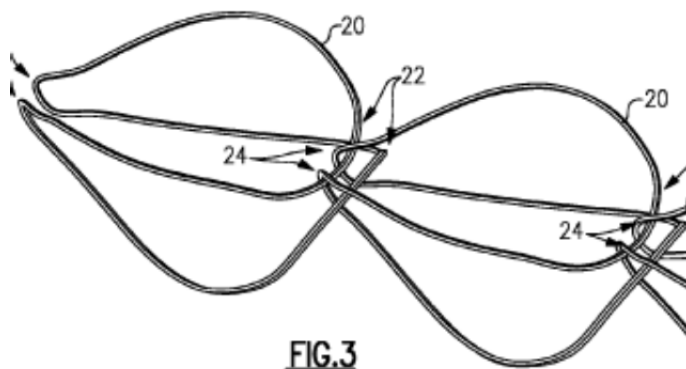

(’565 patent Fig. 3.) With enough such links, one can create a wearable item like this bracelet:



(’565 patent Fig. 2.)

Claim 9 of the ’565 patent describes a kit for creating items like the bracelet shown above. With limitations inherited from claim 1,<sup>1</sup> claim 9 gives Choon the exclusive rights to anything fitting this description:

---

<sup>1</sup> Claim 9 is a “child” or “dependent” of claim 1. This means that it “inherits” all the limitations of its “parent” or “independent” claim 1. When a patentee wants to make a new, narrower claim by adding a limitation to an existing claim, instead of rewriting all the limitations in the earlier claim again, the patentee incorporates those limitations by reference. Thus, when properly drafted, child claims necessarily have narrower scope than their parents.

Although claim 1 of the ’565 patent has broader scope than claim 9 then, Choon asserts infringement of claim 9 because it disclaimed (withdrew) claim 1 after the ’565 patent issued. The effect of Choon’s disclaimers has been analyzed at length. *See generally Choon’s Design, LLC v. Zenacon, LLC*, No. 2:13-CV-13568, 2015 WL 539441 (E.D. Mich. Feb. 9, 2015).

A kit for creating an item consisting of a series of links, the device comprising:

a base; []

at least one *pin bar supported on the base*, the pin bar including a plurality of pins each including *a top flared portion for holding a link in a desired orientation and an opening on a front side of each of the plurality of pins*]; and]

a *clip* for securing ends of the series of links together.

('565 patent col. 5, ll. 10–16; '565 patent col. 6, ll. 1–2 (disputed claim terms emphasized).) The following is picture of four example bases (12), three example pin bars (14) mounted on three of the bases, pins (26), and one clip (18):

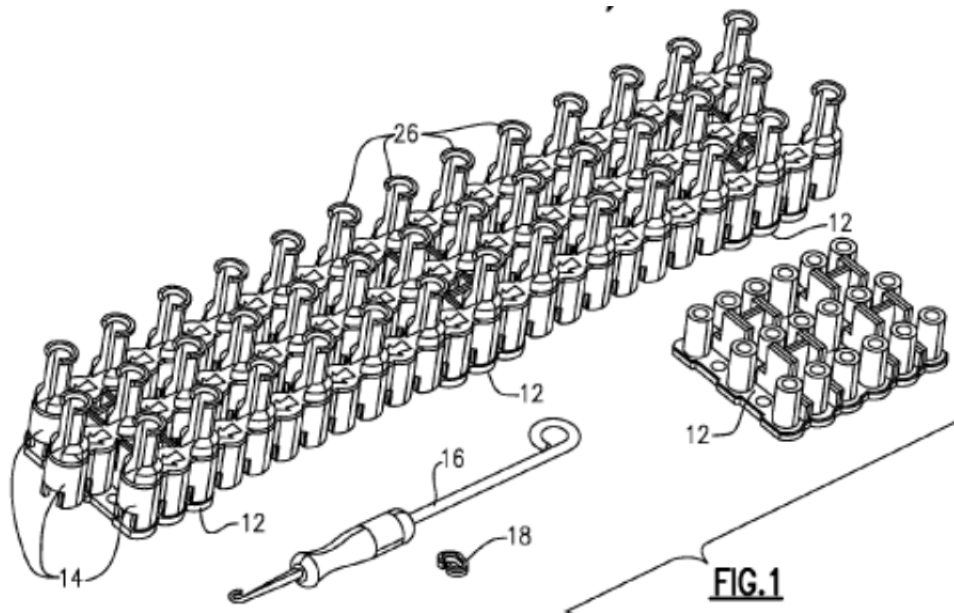

('565 patent Fig. 1.) In an embodiment of Choon's invention, openings (30) in the bottom of the pin bar (14) fit snugly over cylinders (28) of a base (12) so that the pin bar ends up mounted on the base:

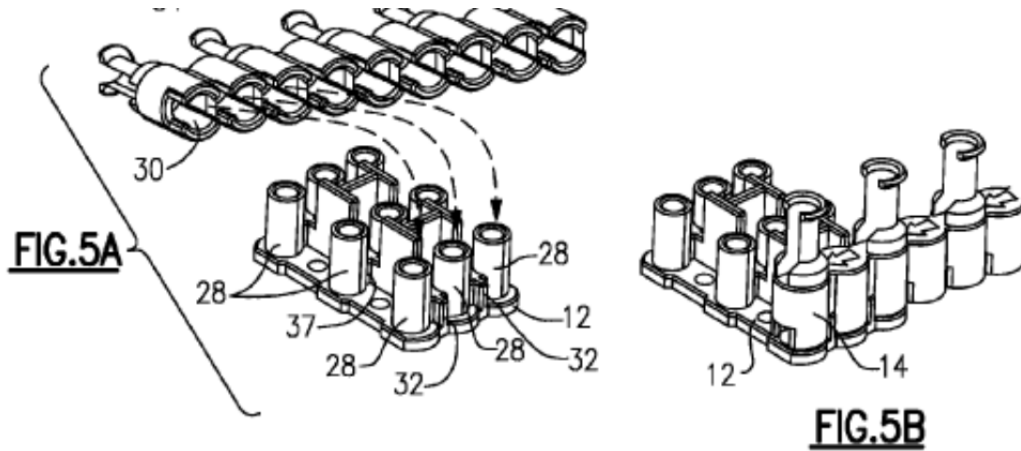

('565 patent Figs. 5A, 5B.)

2.

Choon also asserts infringement of claim 14 of the '565 patent, a method claim setting out steps for linking elastic bands. With limitations inherited from claims 12 and 13, it claims this territory:

A method of creating a linked item comprising the steps of:

*supporting at least one pin bar including a plurality of pins to a base to define a desired relative [spatial] relationship between at least two adjacent pins;*

*assembling at least two elastic bands across adjacent pins wherein a second of the at least two elastic bands is placed atop one end of the first of the at least two elastic bands on a common pin;*

*capturing one end of an elastic band and pulling the end over and onto an adjacent pin while engaged with another elastic band wherein capturing one end of the elastic band includes using a hook tool reaching into an access groove of the pin to extend below the top most elastic band and grasp a bottom elastic band with the hook tool; and*

*capturing and pulling subsequent ends over until a desired link length and configuration is obtained.*

('565 patent col. 6, ll. 7-26 (disputed claim terms emphasized).)

In an embodiment, the method of claim 14 is carried out this way:

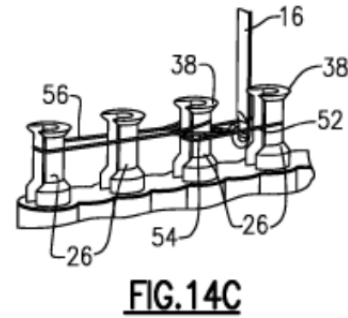
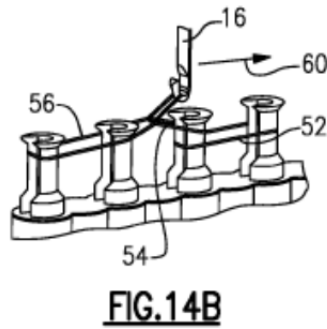
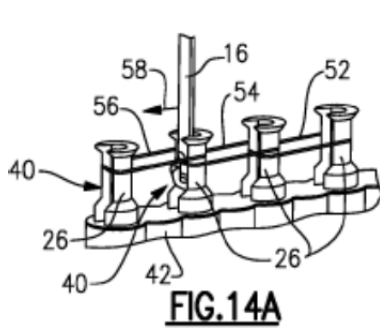

(’565 patent Figs. 14A–14C.)

### 3.

On April 1, 2014, the United States Patent and Trademark Office issued Choon a second utility patent, United States Patent No. 8,684,420. (Dkt. 150, Jt. Claim Constr. App’x Ex. 3, ’420 patent; 4th Am. Compl. ¶ 39.) With the exception of removing discussion of a “pin bar” from the last two sentences of the Abstract, the ’420 patent, as a continuation, shares the same written description as the ’565 patent. As the modification to the Abstract suggests, the claims of the ’420 patent do not mention a pin bar. (*See* ’420 patent cols. 5–6.)

The parties ask the Court to construe terms in claim 3 of the ’420 patent. (*See* Dkt. 160, Jt. Claim Constr. Chart.) Claim 3 is a child of claim 1 and with its parent’s limitations it reads:

A device for creating an item consisting of a series of links, the device comprising:

*a base; and*

*a plurality of pins supported on the base, wherein each of the plurality of pins includes a top portion for holding a link in a desired orientation wherein the top portion comprises a flared portion for holding a link in place on at least one of the plurality of pins and an opening on at least one side of each of the plurality of pins, wherein the plurality of pins comprises rows of offset pins spaced apart and extending upward from the base.*

(’420 patent col. 5, ll. 18–26, 30–33 (disputed claim terms emphasized).)

**B.**

Choon filed this lawsuit in August 2013 (Dkt. 1) and a Fourth Amended Complaint in July 2014 (Dkt. 81). Choon alleges that “[a]fter taking note of Choon’s great success” IdeaVillage (along with three other defendants that have since settled their dispute with Choon) “decided to take action, producing their own loom kit, the Fun Loom.” (Dkt. 81, 4th Am. Compl. ¶ 16.) The following are images of a Fun Loom:



(Dkt. 114, Choon’s Mot. for Prelim. Inj. Ex. 8; Dkt. 156, Choon’s Sealed Mot. for Claim Constr. at 6.)

Choon has acknowledged what is suggested by these pictures: the Fun Loom “is a one piece item.” (Choon’s Sealed Mot. for Claim Constr. at 6; *see also* Dkt. 115, Choon’s Sealed Mot. Prelim. Inj. at 7.) Choon maintains, however, that “the one-piece construction of the Fun Loom does not avoid the patent claims.” (Choon’s Sealed Mot. Prelim. Inj. at 8.)

IdeaVillage disagrees. Not only does IdeaVillage say that its Fun Loom does not fall within the scope of the claims of the ’565 patent or the ’420 patent, it asserts that those two patents are, for various reasons, invalid. (*See* Dkt. 88, IdeaVillage’s Counterclaims ¶¶ 26, 31.)

The parties now ask the Court to narrow their dispute by construing ten claim terms found in the ’565 patent and the ’420 patent. (Dkt. 156, Choon’s Sealed Mot. for Claim Constr. (“Choon’s Mot.”); Dkt. 157, IdeaVillage’s Mot. for Claim Constr. (“IdeaVillage’s Mot.”); *see also* Dkts. 149, 150, 155, 158, 159, 160.)

## II.

“The words of a claim are generally given their ordinary and customary meaning as understood by a person of ordinary skill in the art when read in the context of the specification and prosecution history.” *Starhome GmbH v. AT & T Mobility LLC*, 743 F.3d 849, 856 (Fed. Cir. 2014) (quoting *Thorner v. Sony Computer Entm’t Am. LLC*, 669 F.3d 1362, 1365 (Fed. Cir. 2012)). “There are only two exceptions to this general rule: 1) when a patentee sets out a definition and acts as his own lexicographer, or 2) when the patentee disavows the full scope of a claim term either in the specification or during prosecution.” *Id.* (quoting *Thorner*, 669 F.3d at 1365). “To act as its own lexicographer, a patentee must clearly set forth a definition of the disputed claim term other than its plain and ordinary meaning,” and “[t]he standard for disavowal of claim scope is similarly exacting.” *Thorner*, 669 F.3d 1365–66.

As these rules for claim construction suggest, the intrinsic record—the patent’s claims, written description, and prosecution history (including the prior art cited during prosecution)—is of primary import. *Phillips v. AWH Corp.*, 415 F.3d 1303, 1317 (Fed. Cir. 2005) (en banc).<sup>2</sup> Everything else—dictionary definitions, expert testimony, and the like—is considered extrinsic evidence and often has a lesser role to play in claim construction. *See id.* Still, there is no rigid process for construing claims and this Court, in its sound discretion, may consult any evidence at

---

<sup>2</sup> A patent “consist[s] principally of a specification that concludes with the claims.” *Phillips*, 415 F.3d at 1316. The purpose of the “written description” portion of the specification (as opposed to the claim portion) is to teach the public how to make and use the claimed invention. *See* 35 U.S.C. § 112(a) (“The specification shall contain a written description of the invention, and of the manner and process of making and using it, in such full, clear, concise, and exact terms as to enable any person skilled in the art to which it pertains, or with which it is most nearly connected, to make and use the same . . .”). Courts sometimes use the terms written description and specification synonymously although they are technically distinct. *See* 35 U.S.C. § 112(b) (“The specification shall conclude with one or more claims particularly pointing out and distinctly claiming the subject matter which the inventor or a joint inventor regards as the invention.”).



any point in the analytical process: “[W]e [have] recognized that there is no magic formula or catechism for conducting claim construction. Nor is the court barred from considering any particular sources or required to analyze sources in any specific sequence, as long as those sources are not used to contradict claim meaning that is unambiguous in light of the intrinsic evidence.” *Id.* at 132.

“Ultimately, the interpretation to be given a term can only be determined and confirmed with a full understanding of what the inventors actually invented and intended to envelop with the claim. The construction that stays true to the claim language and most naturally aligns with the patent’s description of the invention will be, in the end, the correct construction.” *Phillips*, 415 F.3d at 1316 (quoting *Renishaw PLC v. Marposs Societa’ per Azioni*, 158 F.3d 1243, 1250 (Fed. Cir. 1998)).

#### A.

The Court first resolves the parties’ dispute over this claim term: “supported on.”

The parties’ constructions of this term, and the related terms “kit,” “a base,” and “pin bar,” reflect their infringement positions in this case. Choon’s constructions of these four terms revolve around its belief that neither the claim language nor the intrinsic record excludes a pin bar from being integrated with the bottom of the claimed device, i.e., the pin bar and base may be one piece. It takes this position, quite apparently, because of the Fun Loom’s one-piece design. IdeaVillage’s constructions of these terms revolve around its belief that the written description only discloses pin bars and bases as separate pieces that can be detached from one another. This position is also taken, quite obviously, because of the Fun Loom’s one-piece design. So the parties’ conflict as to the meaning of four claim terms (“supported on,” “a base,” “kit,” and “pin bar”) can be largely resolved by answering this question: do the asserted patent claims cover

only devices with pin bars and bases that can be detached from one another (IdeaVillage's position) or do they also cover devices where the pin bar and base are integrated into a single unit (Choon's position)?

The term "supported on" appears in claim 9 of the '565 patent, claim 14 of the '565 patent (in the form "supporting"), and claim 3 of the '420 patent.

### 1.

The Court begins with claim 9 of the '565 patent. This phrase from that claim is the critical language: "at least one pin bar supported on the base." Choon says that the term "supported on" means "integral with or attached to the base." (*See* Dkt. 160, Jt. Claim Constr. Chart.) Substituting in Choon's definition leads to this proposed construction of the phrase under scrutiny: "at least one pin bar [integral with or attached to] the base." Making a likewise substitution using IdeaVillage's definition for "supported on" yields this proposed construction: "at least one pin bar [maintained in one desired alignment on] the base." (*See* Jt. Claim Constr. Chart.) As evidenced by IdeaVillage's other proposed constructions, "desired" in its definition means that the user of the loom can attach pin bars to, and detach pin bars from bases as he or she desires. (*See id.*)

Choon's proposed construction is not the most natural interpretation of the phrase. A more natural way to have claimed what Choon now says claim 9 means would have been to use the word "portion" (and perhaps the word "by" rather than "on"): "the device comprising: a base portion; and at least one pin bar portion supported by the base portion." Indeed, in the case Choon primarily relies upon, the Federal Circuit said that the word "portion" "unambiguous[ly] . . . encompass[ed] meanings of both 'integral' and 'separate.'" *Rexnord Corp. v. Laitram Corp.*, 274 F.3d 1336, 1348 (Fed. Cir. 2001).

Still, the claim language as written does not plainly exclude Choon’s construction. Choon is correct that neither “supported” nor “on”—while both suggesting an object supported by a different object—plainly excludes integration. See Merriam-Webster, *support* (transitive verb), <http://www.merriam-webster.com/dictionary/supported> (last visited Aug. 13, 2015) (“to hold up or serve as a foundation or prop for”); Merriam-Webster, *on* (preposition), <http://www.merriam-webster.com/dictionary/on> (last visited Aug. 13, 2015) (“used as a function word to indicate position in contact with and supported by the top surface of”).<sup>3</sup>

And it is not too difficult to imagine an object with an integrated base the remainder of which is “supported on” that base. Consider, for example, this statue carved from marble:

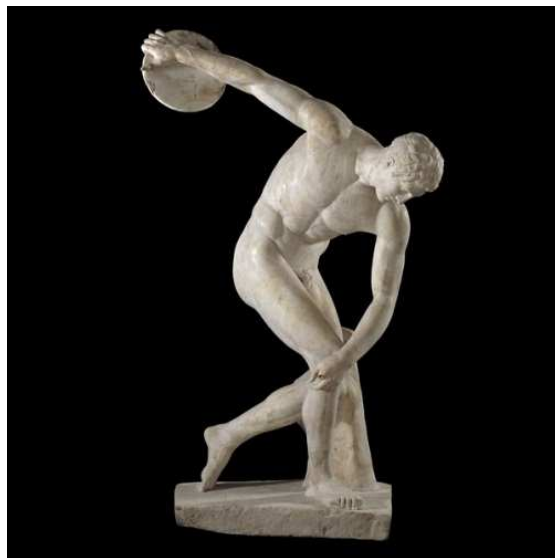

The British Museum, *Discus-thrower (discobolus)*, [http://www.britishmuseum.org/explore/highlights/highlight\\_objects/gr/d/discus-thrower\\_discobolus.aspx](http://www.britishmuseum.org/explore/highlights/highlight_objects/gr/d/discus-thrower_discobolus.aspx) (last visited Aug. 13, 2015) (Creative Commons Code CC BY-NC-SA 4.0). Certainly one could (and perhaps even would) refer to the portion of the statue upon which the discus thrower is standing as the statue’s “base.”

---

<sup>3</sup> As both parties rely on definitions from the Merriam-Webster dictionary found at <http://www.merriam-webster.com/>, where possible, the Court also takes its definitions from that dictionary.

So the above object could be claimed this way: “a statue comprising: a base; and a discus thrower supported on the base.” And Choon would be correct to point out that this is analogous to the language at issue in claim 9 and that the discus thrower is “integrated with” the base (the statue appears to have been carved from a single piece of rock).

While the plain language of the phrase “at least one pin bar supported on the base” thus permits Choon’s constructions of “supported on,” the written description of the ’565 patent all but explicitly precludes it. The written description, which, again, was drafted by Ng through counsel, repeatedly extolls the benefits of a loom having separate pin bars and bases that can be attached to and detached from one another:

As is appreciated, the extent to which additional bases and pin bars 14 can be added and the configurations possible are limited only b[y] the desire of the user of the disclosed kit. *The addition of pin bars 14 provides for more unique and intricate designs limited only by the imagination of the user of the kit. . . .*

The example base template 12 can be arranged to support many pin bars 14 and therefore links can be formed longitudinally and laterally across adjacent pin bar 14 *to form a wide variety of link configurations and combinations. . . .*

As appreciated, any number of base templates 66 can be secured to each other to form many different desired configurations. *The different configurations provide for many options for creating different shapes and configurations of wearable items.*

(’565 patent col. 3, ll. 56–61; ’565 patent col. 4, ll. 24–28; ’565 patent col. 4, ll. 57–61 (emphases added); *see also* ’565 patent col. 1, ll. 48–50; ’565 patent col. 3, ll. 39–42.) That these passages constitute important disclosure is underscored by the fact that the detachable-pin-bars feature takes up two sentences of the patent’s five-sentence Abstract: “The base and pin bars may be assembled in various combination and orientations to provide endless variation of completed link orientations. Additional bases and pin bars can be [added] to further expand possible completed article creation.” (’565 patent, Abstract.) Thus, a person having ordinary skill

in the art, reading the claims in view of the written description at the time of the invention, would have surely thought that an important aspect of the invention of the '565 patent was the ability to detach and reconfigure the pin bars on bases.

And any doubt in the mind of this person with ordinary skill in the art would have been quelled by the fact that *every* single embodiment disclosed in the written description, and *every* single drawing of the pin bars and bases, shows the pin bars and bases as separate pieces that can be attached and detached. In fact, when the Court asked Choon at oral argument to identify any specification language that does not teach separate pin bars and bases, Choon could only point to the following: “. . . the example kit 10 includes a base 12 that supports pin bars 14 that each includes a plurality of pins 26.” (*See also* Choon’s Mot. at 21.) True, this quoted language is entirely silent on how the base “supports” pin bars and so it can be read as encompassing an integrated, one-piece design. The problem for Choon is that it has stripped this quote of its context. The sentence that Choon cites starts this way: “Referring to FIG. 1, . . . .” (’565 patent col. 2, ll. 43–44.) And Figure 1 of the ’565 patent, reproduced in Part I.A.1 of this opinion, plainly shows pin bars mounted on and detachable from bases. This is to say nothing of the remainder of the paragraph from which Choon cites, which discusses detachable pin bars. (’565 patent col. 2, ll. 49–53 (“In this example, a center pin bar 14 is incremented one up from the two outermost pin bars 14. In this example three bases 12 are utilized to support the pin bars 14 in a desired relative orientation.”).)

Choon makes several attempts to escape what the written description unmistakably reveals about the scope of claim 9 of the ’565 patent. None are availing.

For one, Choon relies heavily on the Federal Circuit’s warning to district courts that embodiments disclosed in the specification are just that—examples of the invention but not the

invention. *See* (Choon’s Mot. at 17); (Dkt. 158, Choon’s Resp. at 9); *Liebel-Flarsheim Co. v. Medrad, Inc.*, 358 F.3d 898, 906 (Fed. Cir. 2004) (“Even when the specification describes only a single embodiment, the claims of the patent will not be read restrictively unless the patentee has demonstrated a clear intention to limit the claim scope using words or expressions of manifest exclusion or restriction.” (internal quotation marks omitted)); *Rexnord Corp. v. Laitram Corp.*, 274 F.3d 1336, 1344 (Fed. Cir. 2001) (“Our case law is clear that an applicant is not required to describe in the specification every conceivable and possible future embodiment of his invention. . . . Specifications teach. Claims claim.” (internal quotation marks omitted)).

The Court has heeded this warning. But it has done so in light of the fact that the ordinary meaning of “at least one pin bar supported on the base” is not so plain: it does not dictate an answer to the question of whether the base and pin bar may be integrated or must be separate. *Cf. Kaneka Corp. v. Xiamen Kingdomway Grp. Co.*, — F.3d —, No. 2014-1373, 2015 WL 3613644, at \*4 (Fed. Cir. June 10, 2015) (“An adjective such as ‘sealed’ may have more than one plain and ordinary meaning.”). As such, this is not a case of limiting claim language that plainly encompasses an integrated design because the specification discloses only two-piece assemblies. Rather, this is a case of determining what one skilled in the art would understand less-than-entirely-plain claim language to mean after he or she reads the written description. *See Kaneka Corp.*, 2015 WL 3613644, at \*4 (“The specification is the single best guide to the meaning of a disputed term.” (internal quotation marks omitted)); *Phillips*, 415 F.3d at 1316 (“The construction that stays true to the claim language and most naturally aligns with the patent’s description of the invention will be, in the end, the correct construction.”); *Vitronics Corp. v. Conceptronic, Inc.*, 90 F.3d 1576, 1582 (Fed. Cir. 1996) (“[T]he specification is always highly

relevant to the claim construction analysis. Usually, it is dispositive; it is the single best guide to the meaning of a disputed term.”).

Moreover, to the extent that it is improper to restrict a claim’s scope to the specification’s embodiments, it is also improper to interpret a claim in such a way that it does not encompass an important feature of the invention. *Toro Co. v. White Consolidated Industries, Inc.*, 199 F.3d 1295 (Fed. Cir. 1999), illustrates this principle.

There, The Toro Company had invented an improved combination leaf blower and leaf vacuum. Prior art had taught a combined vacuum-blower where the user “place[d] a protective cover over the air inlet” when the tool was in blower mode. *Toro*, 199 F.3d at 1297. In Toro’s improvement, the protective cover was “fitted with a ring that restricted the size of the air inlet in blower mode.” *Id.* The ring, by restricting the air inlet, allowed the blower to blow harder. *See id.* Toro obtained a patent for this improvement with a claim that read in part, “[the] cover *including* means for increasing the pressure developed by [the] vacuum-blower during operation as a blower.” *Id.* at 1298 (quoting U.S. Patent No. 4,694,528) (emphasis added). White Consolidated introduced a competing vacuum-blower that, unlike Toro’s, had a restriction ring that was “not attached as part of the air inlet cover but was a separate part.” *Id.* White Consolidated claimed that its vacuum-blower was a “successful attempt to design around” the claims of Toro’s patent. *Id.* The district court disagreed: it construed the claim term “including” to “comprehend[] a separate restriction ring that is not part of the cover but is separately inserted and removed.” *Id.* at 1300.

The Federal Circuit reversed. Over a dissent that argued that undoubtedly “the ordinary meaning of ‘include’ does not require physical attachment,” *Toro*, 199 F.3d at 1303 (Rader, J., dissenting), the majority held that the patent claims were limited to a restriction ring that was

“permanently affixed to and included as part of the cover,” *id.* at 1302. In justifying this construction, the majority stressed that the patent’s specification touted the advantages of the restriction ring being affixed to the cover: “it automatically restricts the size of air inlet depending upon which operation is being conducted without having the operator manually insert or remove a replaceable ring.” *Id.* at 1301 (quoting U.S. Patent No. 4,694,528, col. 7, ll. 6–12). The majority also relied on the fact that the sole embodiment disclosed in the specification “show[ed] the restriction ring as ‘part of’ and permanently attached to the cover” and none of the patent’s twenty-one drawings showed anything different. *Id.* at 1301. The Federal Circuit further explained that this was “not a case of limiting the claims to a ‘preferred embodiment’ of an invention that has been more broadly disclosed” or “a case of limiting claims to immaterial details of a broader invention as set forth in the specification.” *Id.* at 1301–02. Instead, it was a situation where the specification had failed to disclose an invention fitting the claim construction urged by the patentee. *Id.* at 1302.

So too here. Each and every discussion of the pin bars and bases in the specification of the ’565 patent treats the two parts as separate with the ability to engage and disengage each other. (*See e.g.*, ’565 patent col. 3, ll. 45–47 (“The base 12 can engage and be [*sic*] receive three pin bars 14 longitudinally, and/or may be added to a side of a group of pin bars to add additional pin bars beyond the three provided for by one base 12.”).) Of all the ’565 patent’s twenty drawings, not one shows a pin bar permanently integrated with a base. Further, similar to the patent in *Toro* touting the cover-ring assembly, the ’565 patent discusses the virtues of configurable pin bars and bases, and the Court cannot say that, given the repeated emphasis on the feature, it is merely an “immaterial detail[] of a broader invention.” *Toro*, 199 F.3d at 1302. Instead, one skilled in the art would understand it to be an “important” part of what Ng invented.



See *Liebel-Flarsheim Co. v. Medrad, Inc.*, 358 F.3d 898, 908 (Fed. Cir. 2004) (distinguishing *Toro* on the basis that the specification in *Toro* described a particular structure as “important to the invention”).

Choon also argues that the Court must adopt its construction because, in *Rexnord Corp. v. Laitram Corp.*, 274 F.3d 1336 (Fed. Cir. 2001), the Federal Circuit decided an indistinguishable issue. (Choon’s Resp. at 1.) The Court disagrees with Choon that *Rexnord* requires that the phrase “at least one pin bar supported on the base” be construed as encompassing an integrated-pin-bar-and-base device.

In *Rexnord*, the patented invention was a “specially-shaped ‘transfer conveyor’” (for, say, conveying bottles in a manufacturing facility). 274 F.3d at 1339. The transfer conveyor was made with a series of “chain links.” The “chain links,” in the language of one of the claims at issue, “includ[ed] a link module portion . . . and a cantilevered portion extending laterally from said link module portion.” *Id.* at 1340 (quoting U.S. Patent No. 5,634,550.) This picture illustrates the chain link and its two portions:

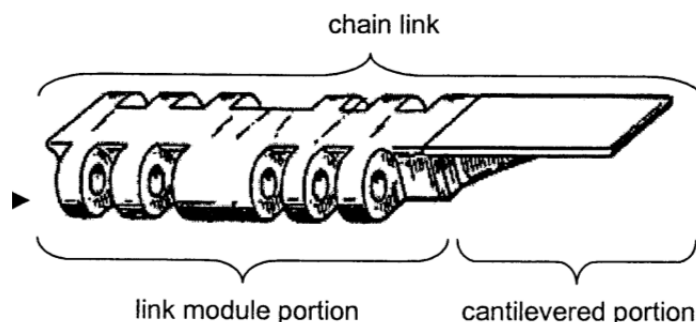

*Id.* at 1340. In the allegedly infringing conveyor, the link module portion and the cantilevered portion were a single, integrated piece. So the question was whether the claim language above captured the accused device’s one-piece chain link.

The Federal Circuit answered this question in the affirmative. The Court explained that the plain and ordinary meaning of the term “portion” included both “separable from the whole”

and “not separated from the whole.” *Rexnord*, 274 F.3d at 1343. It then reasoned that this plain and ordinary meaning controlled unless the patent specification (or patent prosecution history) limited the scope of the claims. *See* 1342–44. The Court found that the specification did not restrict the plain language of the claim because, while one embodiment taught a separate cantilevered portion, two other embodiments did “not describe two-piece, or separate, constructions.” *Id.* at 1345. In fact, one of these two embodiments was “described completely without the use of any words that connote a quality of being ‘separate’—such as ‘attachment,’ ‘mountable,’ ‘second piece,’ or ‘securable.’” *Id.* The Federal Circuit summarized the basis for its construction this way:

In the end, we have a term, “portion,” that is unambiguous in encompassing meanings of both “integral” and “separate.” When the invention is being described in the specification (as opposed to when the preferred embodiment is being described), we have two distinct embodiments distinguished from one other embodiment. With the score two to one (i.e., two embodiments broadly defined as opposed to one narrowly described), the embodiments not restricted to “separate” structures must be understood to refer to a single structure that includes both the “link module” and “cantilevered” portions.

*Rexnord*, 274 F.3d at 1348.

This case is not like *Rexnord*. For one, *Rexnord* involved the claim term “portion” and, as stated at the outset of the Court’s analysis, that word would have been a much more natural way to claim what Choon now says claim 9 means. Indeed, the Federal Circuit held in *Rexnord* that the word “portion” “is *unambiguous* in encompassing meanings of both ‘integral’ and ‘separate,’” 274 F.3d at 1348 (emphasis added). Again, the comparable “supported on” of claim 9 does not so plainly include both integral and separate. Second, every single embodiment disclosed in the ’565 patent’s specification teaches a separate bin par and base. As noted, when asked, Choon could not identify any exception. In contrast, the *Rexnord* patent disclosed two embodiments without using language indicating separate structures: “The chain links also

include cantilevered portions that extend laterally from the link module portions to provide an extension of the article supporting surface of the second conveyor.” U.S. Patent No. 5,634,550 col. 2, ll. 51–54; *see also Rexnord*, 274 F.3d at 1348. These distinctions make a difference. So the Court does not agree with Choon that *Rexnord* dictates that the claim language “at least one pin bar supported on the base” be construed as encompassing a loom with an integrated pin bar and base.

Choon also relies on the doctrine of claim differentiation in support of its construction. That claim-construction cannon basically says that where a child claim adds a limitation, the Court should presume that its parent did not already have the limitation. *See Seachange Int’l, Inc. v. C-COR, Inc.*, 413 F.3d 1361, 1369 (Fed. Cir. 2005). Choon relies on claim 2 (a child of claim 1), which reads, “The kit as recited in claim 1, wherein the pin bar and the base including corresponding mating features for securing the pin bar to the base.” Choon says that because claim 2 adds “securing the pin bar to the base,” that claim, not claim 1, introduces the limitation that the pin bar and the base are separate pieces that can be detached from one another. (*See* Choon’s Mot. at 21–22.) This, says Choon, means that claim 1 (and therefore claim 9 which adds only a clip to the invention of claim 1) necessarily encompasses a device with an integrated pin bar and base. (*See id.*)

Not necessarily. As IdeaVillage points out (Dkt. 159, IdeaVillage’s Resp. at 13 & n.14), the doctrine of claim differentiation can be applied equally well with a contrary result. One could read claim 2 as specifying a particular manner in which the pin bar is supported on the base, i.e., via “mating features” (as opposed to any number of other fastening means). So read, claim 2 does not add the limitation of separate pin bar and base components and does not preclude claim 1 from including that limitation.

Choon further argues that the International Trade Commission, during its 2014 investigation of infringement of the '565 patent, adopted Choon's construction of "integral with or attached to." (Choon's Mot. at 18–19.) Choon stresses that the investigation involved an administrative law judge and a staff attorney learned in patent law and that staff attorneys "will take an active role in challenging the patent-in-suit." (*Id.*) But Choon cites not a single case in which a federal district court gave an ITC finding significant weight. (*See* Choon's Mot. at 19 (citing cases).) And in this particular case, as IdeaVillage points out (IdeaVillage's Resp. at 19–20), the ITC proceeding was uncontested by any of the nine accused infringers (most defaulted) and the staff attorney simply argued that if the ALJ elected to construe the claims, the terms should be given their plain and ordinary meaning. (Choon's Mot. Ex. 7, *In the Matter of Certain Loom Kits for Creating Linked Articles*, Inv. No. 337-TA-923, slip op. at 1–3, 25 (USITC Feb. 3, 2015).) Moreover, Choon informed the Court at oral argument that not one of the accused devices involved in the ITC investigation were one-piece looms—each had separate pin bars and bases like Choon's Rainbow Loom. As such, the ITC had no reason to question whether the language "at least one pin bar supported on the base" encompassed an integrated design. Under these circumstances, the Court is not persuaded by the ITC's constructions.

\* \* \*

The parties' arguments thus having been fully considered, the Court will construe the phrase "at least one pin bar supported on the base" in claim 9 of the '565 patent as meaning "at least one pin bar *attached to but detachable from* the base." The word "detachable" means capable of being separated without damage. *See* Merriam-Webster Unabridged, *detachable* (*adjective*), <http://unabridged.merriam-webster.com/unabridged/detachable> (last visited Aug. 13, 2015).

## 2.

The parties agree that claim 14 of the '565 patent should be interpreted consistently with claim 9 of that patent. (*See* Jt. Claim Constr. Chart.) The Court agrees. *See Omega Eng'g, Inc. v. Raytek Corp.*, 334 F.3d 1314, 1334 (Fed. Cir. 2003) (“[W]e presume, unless otherwise compelled, that the same claim term in the same patent . . . carries the same construed meaning”). So the Court construes the phrase “supporting at least one pin bar including a plurality of pins to a base” in claim 14 as “*attaching* at least one pin bar including a plurality of pins to a base *such that the at least one pin bar is detachable from the base.*” As before, the word “detachable” means capable of being separated without damage.

## 3.

As for claim 3 of the '420 patent, it, like claim 9 of the '565 patent, uses the term “supported on.” (*See* Jt. Claim Constr. Chart.) “[O]rdinarily” claims are interpreted “consistently across patents having the same specification.” *In re Katz Interactive Call Processing Patent Litig.*, 639 F.3d 1303, 1325 (Fed. Cir. 2011). As noted, save for the last two sentences of the two patents’ abstracts, the '565 and '420 patents have an identical written description. Thus, the parties quite reasonably urge the Court to assign the term “supported on” the same meaning in both patents. (*See* Jt. Claim Constr. Chart; Choon’s Mot. at 10–11; IdeaVillage’s Mot. at n.9, n.15.)

But “ordinarily” means that there are exceptions; this case is one of them. As explained, although not the most natural construction of the phrase “at least one pin bar supported on the base,” that language of claim 9 of the '565 patent is amenable to Choon’s position that the claim covers one-piece looms. The Court ultimately rejected Choon’s construction given the '565

patent's written description: that critical piece of intrinsic evidence describes only detachable pin bars and bases and repeatedly stresses the benefits of that feature.

Now consider the '420 patent and, in particular, the language of claim 3 which the parties ask the Court to construe. It reads, "a base; and a plurality of *pins* supported on the base." ('420 patent col. 5, ll. 20–21 (emphasis added).) There is no mention of a pin bar. This means that the Court's central reasoning, and the essence of IdeaVillage's arguments, regarding the '565 patent—the specification's exclusive discussion of *pin bars* that detach from bases and its repeated stressing of that feature—applies with much less force to the '420 patent: the claim language simply does not involve pin bars. Indeed, the '420 patent specification provides not even one example of "pins supported on the base" apart from the use of a pin bar. True, the Abstract says, "The pins may be assembled in various combination and orientations to provide endless variation of completed link orientations," but this sentence is preceded by two about the base and pin bar: "The example kit provides for the successful creation of unique wearable articles using Brunnian link assembly techniques and includes several pin bars that are supported in a desired [spatial] orientation by at least one base. The desired [spatial] orientation is dependent on the desired linked configuration of the completed article." ('420 patent, Abstract.) As such, one skilled in the art reading the Abstract could understand that "[t]he pins may be assembled in various combination and orientations to provide endless variation of completed link orientations" only because one can rearrange the pin bars. In any event, this one sentence is not sufficient to preclude Choon's reading of the claim language "a plurality of pins supported on the base."

Additionally, the written description of the '420 patent does not teach pins as individual pieces that can be attached to or detached from another part of the device. Instead, it discloses

pins as an integrated part of a larger structure: “The pin bar 14 is an integral structure having the plurality of pins 28 defined in a single row.” (’420 patent col. 4, ll. 4–5.) And consider the following drawing found in the specification showing a pin (26) integrated with a “bar portion” (42):

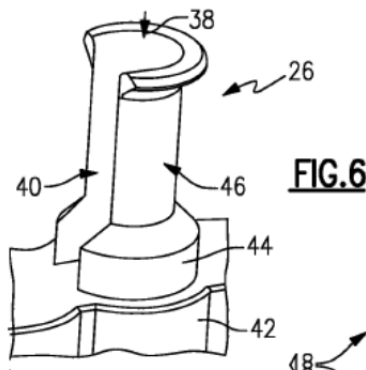

(’420 patent Fig. 6.) This drawing, along with the description of a pin bar as an “integral structure having . . . pins,” especially when contrasted against the disclosure regarding detachable pin bars and bases, would lead a person having ordinary skill in the art to conclude that the phrase, “a base; and a plurality of pins supported on the base” to encompass an integrated pin-base design.

Such a construction is also supported by the history of Choon’s dispute with IdeaVillage (and others who have manufactured a one-piece loom). After the Fun Loom and other similar one-piece looms hit the market, Choon filed an application for what later became the ’420 patent, i.e., Choon drafted the claims of the ’420 patent in an attempt to capture a one-piece design. (See IdeaVillage’s Mot. at 3–4.) Given how the claims of the ’420 patent were a reaction to the sale of one-piece looms, it would be odd to think that the “supported on” language of claim 9 of the ’565 patent referring to “pin bars” means the same thing as the “supported on” language of claim 3 of the ’420 patent referring to “pins.”

So the Court construes the phrase “a plurality of pins supported on the base” of claim 3 of the ’420 patent as follows: “a plurality of pins *integral with or attached to* the base.”

**B.**

In addition to “supported on,” the parties ask the Court to construe seven other terms in claim 9 of the ’565 patent: (1) “a kit” or “a kit for creating an item consisting of a series of links”; (2) “a base”; (3) “pin bar”; (4) “a top flared portion” or “a top flared portion for holding a link in a desired orientation”; (5) “a link”; (6) “an opening on a front side” or “an opening on a front side of each of the plurality of pins”; and (7) “a clip” or “a clip for securing ends of the series of links together.” (*See* Jt. Claim Constr. Chart.)

But the Court believes that the construction it has provided for the phrase “at least one pin bar supported on the base” in claim 9 of the ’565 patent resolves the parties’ central dispute about that claim. Further, the construction allows this case to take several steps forward either by way of settlement discussions, dispositive-motion practice, or a stipulated judgment on certain counts of the Fourth Amended Complaint. Without a more complete understanding of how the parties will proceed following this Court’s construction of the phrase “at least one pin bar supported on the base,” the Court declines—at this time—to construe these seven additional disputed terms of claim 9 of the ’565 patent. *See AstraZeneca LP v. Breath Ltd.*, 542 F. App’x 971, 981 (Fed. Cir. 2013) (“[T]his court has indicated that a district court can dismiss an invalidity counterclaim when it finds noninfringement or dismisses an infringement claim with prejudice.”); *Aqua Marine Supply v. AIM Machining, Inc.*, 247 F.3d 1216, 1220 (Fed. Cir. 2001) (“[W]here, as here, the alleged infringer has settled the infringement issue, and no longer professes any interest in defending its declaratory judgment of invalidity, the case has become moot as a result of the voluntary act of the patentee.”); *but see Telcordia Technologies, Inc. v.*



*Cisco Sys., Inc.*, 612 F.3d 1365, 1375 (Fed. Cir. 2010) (“[T]his court’s affirmance of the district court’s non-infringement findings as to the ’306 patent does not moot Cisco’s invalidity counterclaim on cross-appeal.”).

### C.

As the constructions provided are sufficient for the parties to narrow or completely resolve their dispute over the ’565 patent, remaining for consideration are the disputed claim terms of the ’420 patent. But aside from “supported on” and “a base”—terms for which the constructions provided are sufficient to resolve the parties’ dispute—there is only one other claim term of the ’420 patent that the parties ask the Court to construe: “wherein the top portion comprises a flared portion for holding a link in place on at least one of the plurality of pins.” (*See generally* Jt. Claim Constr. Chart.)

IdeaVillage initially argued that this entire phrase did not need construction. (*See* IdeaVillage’s Mot. at 19.) It asserted in its briefing that only the shorter phrase, “a flared portion,” of claim 3 of the ’420 patent should be construed because the language that follows (“for holding a link in place on at least one of the plurality of pins”) is merely functional and, thus, was entitled to no patentable weight under Federal Circuit precedent. (*Id.*)

But at oral argument, IdeaVillage indicated that it took this position primarily because it had taken the same position regarding functional language in other disputed claim terms. IdeaVillage indicated that if this Court were to separately analyze the functional language of the claims in dispute, it would be amenable to a construction of the entire phrase (“wherein the top portion comprises a flared portion for holding a link in place on at least one of the plurality of pins”).

As such, the Court agrees with Choon that the entire phrase should be construed. *See Textron Innovations Inc. v. Am. Eurocopter Corp.*, 498 F. App'x 23, 28 (Fed. Cir. 2012) (“In certain circumstances functional language may be used to add limitations to an apparatus claim.”).

At oral argument, both Choon and IdeaVillage provided that if the Court were to construe the entire phrase, they would agree to the following construction: “an upper portion that projects outward in shape for maintaining a link in place on at least one of the plurality of pins.” Accordingly, this is the construction that the Court provides for the phrase “the top portion comprises a flared portion for holding a link in place on at least one of the plurality of pins” in claim 3 of the '420 patent.

### III.

For the foregoing reasons, the Court finds that

- (1) in claim 9 of the '565 patent, the phrase “at least one pin bar supported on the base” means “at least one pin bar *attached to but detachable from* the base” where “detachable” means “capable of being separated without damage”;
- (2) in claim 14 of the '565 patent, the phrase “supporting at least one pin bar including a plurality of pins to a base” means “*attaching* at least one pin bar including a plurality of pins to a base *such that the at least one pin bar is detachable from the base*” where “detachable” means “capable of being separated without damage”;
- (3) in claim 3 of the '420 patent, the phrase “a plurality of pins supported on the base” means “a plurality of pins *integral with or attached to* the base”; and
- (4) in claim 3 of the '420 patent, the phrase “the top portion comprises a flared portion for holding a link in place on at least one of the plurality of pins” means “*an upper portion*”

*that projects outward in shape for maintaining a link in place on at least one of the plurality of pins.”*

For reasons explained, the Court declines to construe any other terms in dispute at this time. Choon’s Sealed Motion for Claim Construction (Dkts. 155, 156) is GRANTED IN PART AND DENIED IN PART and IdeaVillage’s Motion for Claim Construction (Dkt. 157) is GRANTED IN PART AND DENIED IN PART.

SO ORDERED.

s/Laurie J. Michelson  
LAURIE J. MICHELSON  
UNITED STATES DISTRICT JUDGE

Dated: August 18, 2015

CERTIFICATE OF SERVICE

The undersigned certifies that a copy of the foregoing document was served on the attorneys and/or parties of record by electronic means or U.S. Mail on August 18, 2015.

s/Jane Johnson  
Case Manager to  
Honorable Laurie J. Michelson