

**UNITED STATES DISTRICT COURT
DISTRICT OF MINNESOTA**

Icon Health & Fitness, Inc.,
a Delaware corporation,

Plaintiff,

v.

**MEMORANDUM
OPINION AND ORDER**
Civil No. 09-319 ADM/SRN

Octane Fitness, LLC,
a Minnesota limited liability company; and
Nellie’s Exercise Equipment, Inc.,
a California corporation,

Defendants.

C.J. Veverka, Esq., David R. Wright, Esq., H. Craig Hall, Jr., Esq., Larry R. Laycock, Esq., and Mark W. Ford, Esq., Workman Nydegger, Salt Lake City, UT; and Jeanette M. Bazis, Esq., and Lawrence M. Shapiro, Greene Espel, P.L.L.P., Minneapolis, MN, on behalf of Plaintiff.

Matthew L. Cutler, Esq., Randy J. Soriano, Esq., Rudolph A. Telscher, Jr., Esq., Harness, Dickey & Pierce, P.L.C., St. Louis, MO; and Michael A. Lindsay, Esq., Dorsey & Whitney, L.L.P., Minneapolis, MN, on behalf of Defendant Octane Fitness, LLC.

I. INTRODUCTION

On October 21, 2010, a Markman hearing was held before the undersigned United States District Judge in this patent infringement action by Plaintiff Icon Health & Fitness, Inc. (“Icon”) against Defendant Octane Fitness, LLC (“Octane”).¹ Icon alleges that Octane infringed claims 1-5, 7, and 9-11 of U.S. Patent No. 6,019,710 (the “710 patent”). Octane denies the

¹ An unrepresented party, Nellie’s Exercise Equipment, Inc. (“Nellie’s”), an Octane distributor, is also a Defendant in this litigation. See Docket. Nellie’s and Octane filed substantially identical counterclaims [Docket Nos. 10, 12, 57]. However, Nellie’s counsel withdrew in June 2009, and Nellie’s has not participated in subsequent court proceedings, including the claim construction process. Mot. To Withdraw as Counsel [Docket No. 83]; see generally Docket. As Nellie’s former counsel represented that the causes of action against Nellie’s are not expected to advance, the Court will proceed with claim construction based on the arguments propounded by Icon and Octane. Mot. To Withdraw as Counsel.

infringement allegations and counterclaims for a declaratory judgment of non-infringement, invalidity, and unenforceability of the '710 patent.

II. BACKGROUND

The '710 patent, entitled "Exercising Device with Elliptical Movement," covers an elliptical exercise machine designed to take up less floor space than prior art models and to allow for adjustable stride length. Pl.'s Opening Mem. Supp. Claim Constr. [Docket No. 131] Ex. A ("710 patent"). The invention also employed a simpler mechanical design than prior art designs. Id. Figure 1 from the '710 patent is shown as Figure 1, below.

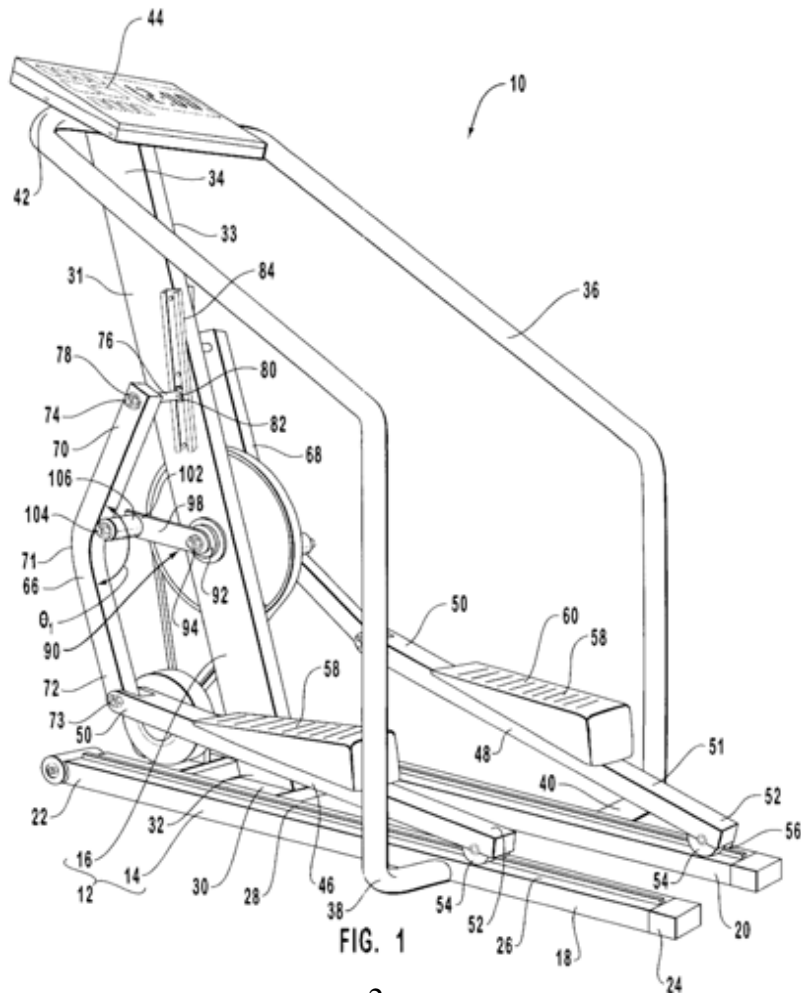

The elliptical machine described in the '710 patent includes a frame with a base configured to rest on a ground surface and a support stand upstanding from the base. '710 patent, col.2 ll.1-4; see, supra, Figure 1 (reproduced above). A hand rail extends from the top of the support stand to each side of the base, and a display board is mounted on top of the hand rail above the support stand. Id. at ll.4-6. The machine also includes two foot rails, spaced apart, that are each connected to the support stand by a stroke rail (see, supra, Figure 1 (no. 70)) and a rotatable crank arm (see, supra, Figure 1, (no. 98)). Id. at ll. 5-6.

During operation, an exerciser places one foot on each foot rail and moves his or her feet back and forth so that the front end of each foot rail moves in a substantially elliptical path. Id. at ll.23-26. When the exerciser's feet move in an elliptical pattern, it simulates a running motion. Id. at ll.28-29.

To create an elliptical machine that would occupy a smaller space, the inventors of the '710 patent placed the foot-rail linking mechanism in front of the device rather than in the back of the device. '710 patent, col.1 ll.30-35; see, infra, Figure 2. In the '710 patent, a stroke rail is attached to the forward end of a foot rail and connected to the frame via: 1) a pin mounted within a C-shaped channel (the "C-channel") (see, infra, Figure 3 (no. 84)) on the support stand; and 2) a collar (see, infra, Figure 2 (no. 106)) encircling a pin (see, infra, Figure 2 (no. 104)) projecting from a rotatable crank arm (see, infra, Figure 2 (no. 98)), which is connected to an axle (see, infra, Figure 2 (no. 92)) extending through the support stand. See, infra, Figure 2 (stroke rail highlighted).

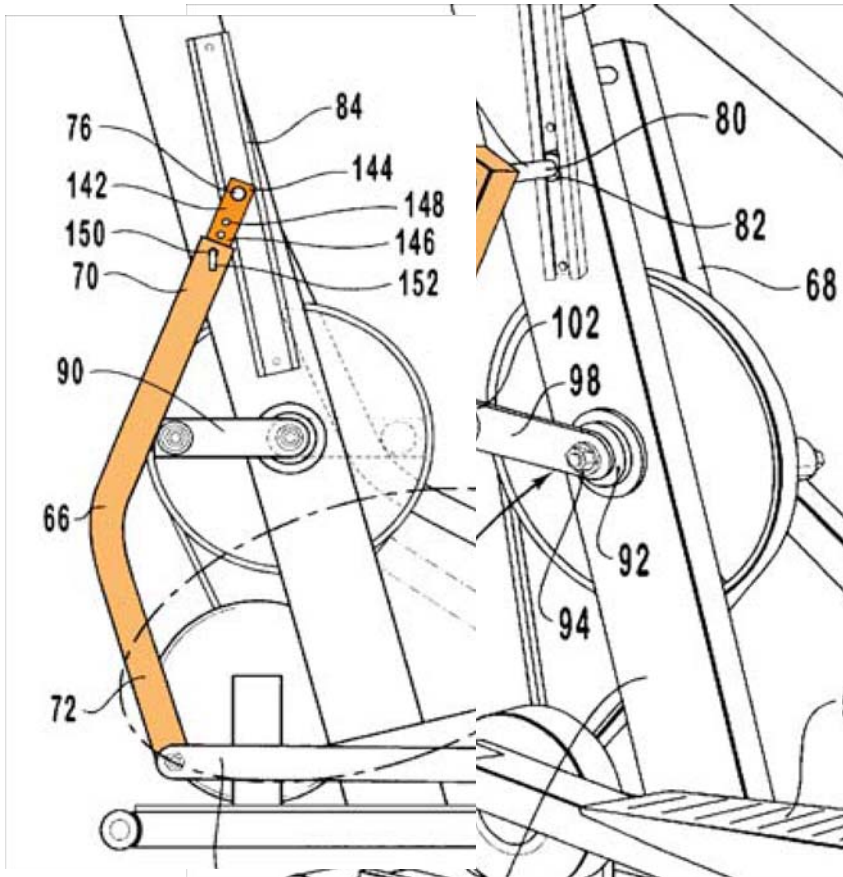

Figure 2

The '710 patent describes two types of stroke rails. The first type, depicted in Figures 1 and 2, is a unitary stroke rail that is not capable of varying in length. See '710 patent, Figs. 1, 5; Pl.'s Opening Mem. Supp. Claim Constr. at 14. The second type of stroke rail has the capability to increase or decrease in length via manual adjustment or motorized adjustment. See '710 patent, Figs. 5, 6; see, infra, Figure 3 (manual), Figure 4 (motorized).

Figure 3

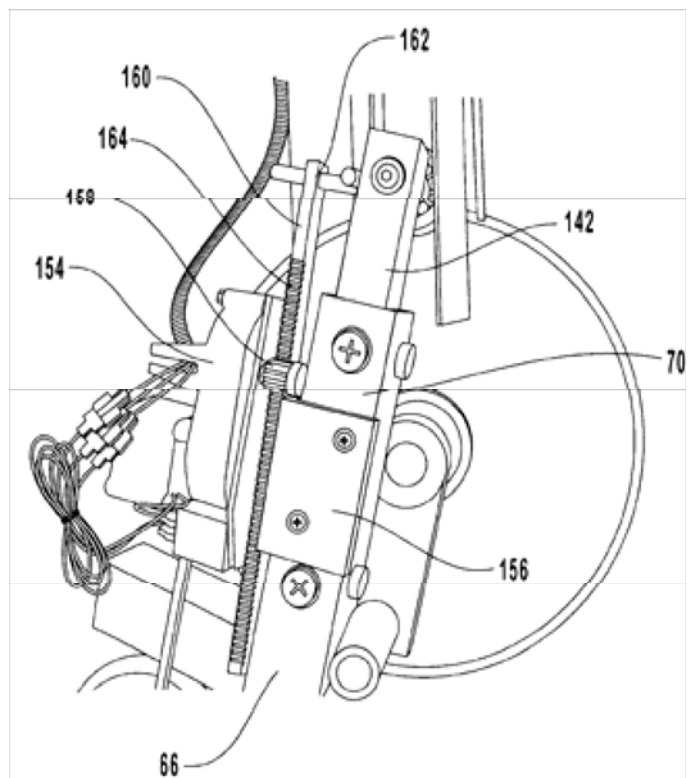

Figure 4

At issue in this litigation are claims 1-5, 7, and 9-11 of the '710 patent. The parties submitted a Joint Claim Construction Statement [Docket Nos. 85, 87, 88], identifying several

disputed claim terms and phrases. The Court will construe two claim terms and three claim phrases.

III. DISCUSSION

A. Standard of Review

Claim construction is a matter of law. Markman v. Westview Instruments, Inc., 52 F.3d 967, 979 (Fed. Cir. 1995), aff'd, 517 U.S. 370 (1996). In construing claims, courts should look first to intrinsic evidence, which includes the claims, the specification, and the prosecution history. Vitronics Corp. v. Conceptronic, Inc., 90 F.3d 1576, 1582 (Fed. Cir. 1996). Claim terms are “generally given their ordinary and customary meaning,” which is “the meaning that the term would have to a person of ordinary skill in the art in question at the time of the invention, i.e., as of the effective filing date of the patent application.” Phillips v. AWH Corp., 415 F.3d 1303, 1312-13 (Fed. Cir. 2005) (quotation and citations omitted). However, a patentee can choose to be “his or her own lexicographer by clearly setting forth an explicit definition for a claim term.” Johnson Worldwide Assocs., Inc. v. Zebco Corp., 175 F.3d 985, 989 (Fed. Cir. 1999). Claim terms “should be construed consistently with [their] appearance in other places in the same claim or other claims of the same patent.” Rexnord Corp. v. The Laitram Corp., 274 F.3d 1336, 1342 (Fed. Cir. 2001). In addition, the specification is usually “dispositive; it is the single best guide to the meaning of a disputed term.” Vitronics, 90 F.3d at 1582. Courts are nonetheless cautioned not to import limitations from the specification into the claims. Phillips, 415 F.3d at 1323; The Laitram Corp. v. NEC Corp., 163 F.3d 1342, 1347 (Fed. Cir. 1998).

While courts can consider extrinsic evidence to educate themselves about the patent and technology at issue, it is improper to rely on extrinsic evidence in construing claims unless, after consideration of all the intrinsic evidence, ambiguity remains. Mantech Envtl. Corp. v. Hudson

Envtl. Servs., Inc., 152 F.3d 1368, 1373 (Fed. Cir. 1998); Vitrionics, 90 F.3d at 1584. Extrinsic evidence is “evidence which is external to the patent and file history, such as expert testimony, inventor testimony, dictionaries, and technical treatises and articles.” Vitrionics, 90 F.3d at 1584. Dictionaries may be useful to courts in understanding the ordinary and customary meaning of words, and courts may “rely on dictionary definitions when construing claim terms, so long as the dictionary definition does not contradict any definition found in or ascertained by a reading of the patent documents.” Phillips, 415 F.3d at 1322-23.

B. “Stroke Rail”

Icon submits that the term “stroke rail” does not need to be construed. Alternatively, Icon proposes the following construction: “A structure comprised of one or more parts that is attached to a foot rail and connected to the frame.” Pl.’s Opening Mem. Supp. Claim Constr. [Docket No. 131] Ex. B (“Disputed Claims Chart”). For its part, Octane submits the following construction: “A linear or curved bar, which can be made to vary in length, extending from a foot rail to a frame on an elliptical machine.” Id.

First, the parties agree that the term “stroke rail” is a term formulated by the patentees and has no meaning to a person of ordinary skill in the art. However, to conclude, as Icon urges, that the stroke rail is “a structure comprised of one or more parts” would impermissibly broaden the scope of the ‘710 patent. Icon’s broad construction excludes other inventors from the use of infinite combinations of parts that link a footrail and a frame on an elliptical machine. See Phillips, 415 F.3d 1303, 1312 (Fed. Cir. 2005) (stating that the words of the patent claim define the invention to which a patentee is entitled the right to exclude). The Court need not look further than the claims and the specification to discover that “stroke rail” cannot be so broadly construed. See Vitrionics, 90 F.3d at 1582. The embodiments of the stroke rail described in the

patent claims and depicted in the specification are relatively simple, with the most complex embodiment consisting of a rail and a motorized extender. The intrinsic evidence, then, makes clear that the term “stroke rail” in the ‘710 patent cannot encompass the complex possibilities implicated by the general phrase “one or more parts” in Icon’s proposed construction.

Still, the Court agrees with Icon’s argument that it serves no meaningful purpose to substitute the word “bar” for the word “rail,” as Octane urges. Additionally, substituting the word “may” for the word “can” in Octane’s proposed construction ensures the construction encompasses both a unitary stroke rail and an adjustable stroke rail. Thus, the Court construes a “stroke rail” to be: A linear or curved rail, which may be made to vary in length, extending from a foot rail to a frame on an elliptical machine.

C. “Linear Reciprocating Displacement”

Octane submits that the term “linear reciprocating displacement” does not require construction. Disputed Claims Chart at 3. In contrast, Icon proposes the following construction: “A change in position from a first point to a second point followed by a change in position from the second point back to the first point, where the change in position from one point to the other results in a net change in position along a line. Linear reciprocating displacement does not require movement along a linear path.” Id.

Octane argues that “linear means linear,” and that the ordinary and customary meaning of “linear reciprocating displacement” is movement back and forth in a straight line. Def.’s Resp. Br. [Docket No. 134] at 22-23. An examination of the ‘710 patent’s claims and specification make clear that one end of a stroke rail slides back and forth (i.e., reciprocates) in a linear path by means of a straight “C-channel.” ‘710 patent, col.2 ll.12-13, col.4 ll.3-17, col.5 ll.46-48, and col.6 ll.14-18; Figs. 1-6; see, supra, Figures 1-3. The claims describe how the first end of the

stroke rail moves back and forth within the C-channel, creating elliptical movement of the second end of the stroke rail. Id. Nothing in the '710 patent indicates that the first end of the stroke rail should move in anything other than a straight line. There is no evidence that the patentees intended the C-channel to be non-linear, or that the first end of the stroke rail be connected to the support stand by anything other than a straight C-channel.

In response, Icon points to various dictionary definitions of the term “linear reciprocating displacement.” However, dictionary definitions are extrinsic evidence. As the construction of the claim term “linear reciprocating displacement” is resolved based on intrinsic evidence – the ordinary and customary meaning of the claim language and the specification – examination of extrinsic evidence is unnecessary and improper. See Mantech, 152 F.3d at 1373; see also Phillips, 415 F.3d at 1312-13 (“Importantly, the person of ordinary skill in the art is deemed to read the claim term not only in the context of the particular claim in which the disputed term appears, but in the context of the entire patent, including the specification.”). Accordingly, the Court concludes that no construction of “linear reciprocating displacement” is necessary.

D. Means-Plus-Function Claim Phrases

The remaining disputed claim elements are subject to a means-plus-function analysis.

Means-plus-function claim elements are interpreted according to 35 U.S.C. § 112, ¶ 6:

An element in a claim for a combination may be expressed as a means or step for performing a specified function without the recital of structure, material, or acts in support thereof, and such claim shall be construed to cover the corresponding structure, material, or acts described in the specification and equivalents thereof.

“Whether certain claim language invokes 35 U.S.C. § 112, ¶ 6 is an exercise in claim construction and . . . a question of law.” Personalized Media Commc'ns, LLC v. Int'l Trade Comm'n, 161 F.3d 696, 702 (Fed. Cir. 1998). The claim phrases construed below are written in

means-plus-function form, and the parties agree that all three claim phrases are to be construed as a means-plus-function elements.

1. **“Means for connecting each stroke rail to the frame such that linear reciprocating displacement of the first end of each stroke rail results in displacement of the second end of each stroke rail in a substantially elliptical path.”**

- i. **Function**

Icon proposes the following function: “connecting each stroke rail to the frame in a manner that results in displacement of the second end of each stroke rail in a substantially elliptical path if the first end undergoes linear reciprocating displacement.” Disputed Claims Chart at 2. Octane proposes that the function recited in this element, “connects each stroke rail to the frame such that linear reciprocating displacement of the first end of each stroke rail results in displacement of the second end of each stroke rail in a substantially elliptical path,” requires no construction because the plain and ordinary meanings of the terms used to describe the function are sufficiently clear. Disputed Claims Chart at 2-3. The Court agrees. See Phillips, 415 F.3d at 1312-13. Thus, no construction of the function is necessary.

- ii. **Corresponding Structure**

Icon proposes the following corresponding structure: “An axle mounted to a pair of crank arms, a pin projecting from each crank arm, and a collar encircling each pin. The axle is mounted to the frame and each collar is attached to a stroke rail.” Disputed Claims Chart at 2. Octane proposes a much narrower description of the corresponding structure, referencing the numbered parts depicted in Figure 1 of the ‘710 patent (see, supra, Figure 1):

- 1) Pin 76 (and the corresponding pin on the opposite side of the frame from pin 76, that is not labeled);
- 2) Nut 78 (and the corresponding nut on the opposite side of the frame from nut 78, that is not labeled);

- 3) Flared head 82 (and the corresponding flared head on the opposite side of the frame from flared head 82, that is not labeled);
- 4) C-shaped channel 84 (and the corresponding C-shaped channel on the opposite side of the frame from C-shaped channel 84, that is not labeled);
- 5) Axle 92;
- 6) Crank arms 98 and 100;
- 7) Nuts 94 and 96;
- 8) Pins 104 and 105 (pin 105 is not labeled in the Figures of the '710 patent);
- 9) Collars 106 and 107 (107 is not labeled in the Figures of the '710 patent);
- 10) Spot welds that hold the two collars, referenced in 9) above, to the stroke rails 66 and 68; and
- 11) Nuts/washers at the end of pins 104 and 105.

Id. at 2-3.

The function of this claim phrase is to connect the stroke rail to the frame in such a way as to cause the first end of the stroke rail to undergo linear reciprocating displacement (which then causes the second end of the stroke rail to move in an elliptical path). The Federal Circuit teaches that the corresponding structure must include all structure that “actually performs the recited function.” Cardiac Pacemakers, Inc. v. St. Jude Med., Inc., 296 F.3d 1106, 1119 (Fed. Cir. 2002); Asyst Techs., Inc. v. Empak, Inc., 268 F.3d 1364, 1371 (Fed. Cir. 2001). Thus, the corresponding structure here must simultaneously connect the stroke rail to the frame and cause the first end of the stroke rail to undergo linear reciprocating displacement.

The parties agree, and the Court accepts, that the corresponding structure includes an axle mounted to the frame and also mounted to a pair of crank arms, a pin projecting from each crank

arm, and a collar encircling each pin that is attached to a stroke rail. The parties disagree as to whether the following are corresponding structure: 1) the C-channel, corresponding pin, and flared head; 2) the spot welds connecting the collar to the stroke rail, and 3) various nuts and washers.

The Court finds that the corresponding structure that performs the recited function must include the C-channel and corresponding pin. Linear reciprocating displacement of the first end of the stroke rail is caused when the pin, which is connected to the stroke rail, moves up and down within the straight C-channel. Icon argues that because claims 8 and 12 of the patent articulate that one end of the stroke rail is “slidably attached,” the “claim differentiation” doctrine dictates that the C-channel cannot be corresponding structure. However, the Federal Circuit has held that the doctrine of claim differentiation cannot override means-plus-function construction required by 35 U.S.C. § 112, ¶ 6. Laitram Corp. v. Rexnord, Inc., 939 F.2d 1533, 1538 (Fed. Cir. 1991) (“Claim differentiation is a guide, not a rigid rule. If a claim will bear only one interpretation, similarity will have to be tolerated.”) (quoting Autogiro Co. of Am. v. United States, 384 F.2d 391, 404 (Ct. Cl. 1967)). Thus, although the C-channel and corresponding pin may be articulated in claims 8 and 12, the C-channel and corresponding pin are not excluded as the corresponding structure for this means-plus-function claim element. See id. (“[A] means-plus-function limitation is not made open-ended by the presence of another claim specifically claiming the disclosed structure which underlies the means clause or an equivalent of that structure.”).

Additionally, the flared head (or the equivalent thereof) must also be included in the corresponding structure because, without it, the pin would slip out of the C-channel (instead of reciprocating in a linear fashion.) See ‘710 patent, col.4 ll.14-16 (stating flared head is “slidably

captured within a C-shaped channel”); Cardiac Pacemakers, 296 F.3d at 1119. Similarly, the nuts and washers (or the equivalent thereof) connecting the pin to the first end of the stroke rail must be included in the corresponding structure. Cardiac Pacemakers, 296 F.3d at 1119.

The same reasoning applies equally to 1) the spot welds attaching the collar to the stroke rail and 2) the nuts and washers connecting the pin to the collar. Without the spot welds, or their equivalents, the collar would not be attached to the stroke rail. As the connection between the collar and the stroke rail is required to produce any movement at all, let alone linear reciprocating displacement, the spot welds are corresponding structure. Similarly, the nuts and washers (or the equivalents thereof) are required to keep the pin within the collar. Icon argues that the corresponding structure cannot be limited by the term “spot welds” because the ‘710 patent’s detailed description of the preferred embodiments states that the collars are “spot welded *or otherwise secured*” to the stroke rails. ‘710 patent, col.4 ll.50-56 (emphasis added). In so arguing, Icon attempts to impermissibly broaden its patent claim. See, e.g., Halliburton Energy Svcs., Inc., v. M-I LLC, 514 F.3d 1244, 1256 n.7 (Fed. Cir. 2008) (noting that § 112, ¶ 6 “was meant to preclude the over breadth inherent in open-ended functional claims . . . which effectively purport to cover any and all means so long as they perform the recited functions”); see also Neopost Industrie B.V. v. PFE Int’l, Inc., No. 04-5047, 2005 WL 6266289, *4 (N.D. Ill. Apr. 26, 2005) (stating “general, catch-all statement cannot eviscerate the requirement that a means-plus-function limitation is ‘sharply limited’ to the structures disclosed in the written description and their equivalents” and refusing to “impermissibly entitle” plaintiff to “claims that are ‘unbounded by any reference to structure’ in the written description.”) (quoting Medical Instrumentation and Diagnostics Corp. v. Elektra AB, 344 F.3d 1205, 1211 (Fed. Cir. 2003)).

The only undisclosed structures that can be included within the construction of a

means-plus-function limitation are the structural equivalents expressly contemplated by § 112 ¶

6. Id. Thus, the spot welds and the nuts and washers connecting the pin to the collar (or the equivalents thereof) are also corresponding structure.

In summary, the Court adopts Octane’s proposed construction for this means-plus-function claim phrase. See Disputed Claims Chart at 2-3.

2. “Means for selectively varying the size of the substantially elliptical path that the second end of each stroke rail travels.”

The parties represented at the hearing that they agree the function, “selectively varying the size of the substantially elliptical path that the second end of each stroke rail travels,” needs no construction.

However, Icon proposes the following construction for the corresponding structure: “(1) An arm with holes along a portion of its length that can be aligned with a pin and a hole in a stroke rail; or (2) an electric motor driving a gear that engages teeth on a bar to move an adjustment arm.” Again, Octane counters with a significantly narrower proposed construction:

There are two embodiments disclosed in the ‘710 patent that contain structure that corresponds to this function. The first embodiment is referred to herein as the “Manual Adjustment Arm Embodiment” and is shown in Figure 5.

The structure from this embodiment that corresponds to the above-referenced function is:

1) Adjustment arm 142 (and the corresponding adjustment arm on the opposite side of the frame from adjustment arm 142, that is not shown in the Figures of the ‘710 patent);

2) Plurality of holes 148 (and the corresponding plurality of holes on the adjustment arm located on the opposite side of the frame from adjustment arm 142, that is now shown in the Figures of the ‘710 patent);

- 3) Complementary hole 150 located in stroke rail 66 (and the corresponding complimentary [sic] hole in stroke rail 68, that is not shown in the Figures of the '710 patent);
- 4) Pin 152 (and the corresponding pin located on the opposite side of the frame from pin 152, that is now [sic] shown in the Figures of the '710 patent);
- 5) Pin 76 (and the corresponding pin on the opposite side of the frame from pin 76, that is not labeled);
- 6) Nut 78 (and the corresponding nut on the opposite side of the frame from nut 78, that is not labeled);
- 7) Flared head 82 (and the corresponding flared head on the opposite side of the frame from flared head 82, that is not labeled; and
- 8) C-shaped 84 (and the corresponding C-shaped channel on the opposite side of the frame from C-Shaped channel 84, that is not labeled).

Disputed Claims Chart at 3-4.

The second embodiment is referred to herein as the “Motorized Adjustment Arm Embodiment” and is shown in Figure 6. The structure from this embodiment that corresponds to the above-reference function is:

- 1) Electric motor 154 (and the corresponding electric motor located on the opposite side of the frame from electric motor 154, that is not shown in the Figures of the '710 patent);
- 2) Bracket 156 (and the corresponding bracket located on the opposite side of the frame from bracket 156, that is not shown in the Figures of the '710 patent);
- 3) Gear 158 (and the corresponding gear located on the opposite side of the frame from gear 158, that is not shown in the Figures of the '710 patent);
- 4) Elongated engagement bar 160 (and the corresponding elongated engagement bar located on the opposite side of the frame from elongated engagement bar 160, that is not shown in the Figures of the '710 patent);

- 5) Teeth 164 (and the corresponding teeth located on the opposite side of the frame from teeth 164, that are not shown in the Figures of the '710 patent);
- 6) Adjustment arm 142 (and the corresponding adjustment arm located on the opposite side of the frame from adjustment arm 142, that is not shown in the Figures of the '710 patent);
- 7) Rod that connects elongated engagement bar 160 to adjustment arm 142 (and the corresponding rod located on the opposite side of the frame from the rod that connects elongated engagement bar 160 to adjustment arm 142, that is not shown in the Figures of the '710 patent);
- 8) Bias mechanism that biases engagement bar 160 against gear 158 (and the corresponding bias mechanism on the opposite side of the frame from engagement bar 160 and gear 158, that is not shown in the Figures of the '710 patent);
- 9) Pin 76 (and the corresponding pin on the opposite side of the frame from pin 76, that is not labeled);
- 10) Nut 78 (and the corresponding nut on the opposite side of the frame from nut 78, that is not labeled);
- 11) Flared head 82 (and the corresponding flared head on the opposite side of the frame from flared head 82, that is not labeled);
and
- 12) C-shaped channel 84 (and the corresponding C-shaped channel on the opposite side of the frame from C-shaped channel 84, that is not labeled).

Id. at 4-6.

First, Icon and Octane disagree as to whether the nuts, washers, spot welds, C-channel, corresponding pin and flared head are corresponding structure. Applying the reasoning set forth in Part D(1)(ii), supra, the nuts, washers, and spot welds described by Octane, or the equivalents thereof, are corresponding structure. Cardiac Pacemakers, 296 F.3d at 1119.

However, the C-channel is not corresponding structure because it does not perform the recited function of “selectively varying the size of the substantially elliptical path that the second

end of each stroke rail travels.” As discussed above, the C-channel is corresponding structure for the function of creating linear reciprocating displacement. The C-channel does not, however, vary the size of the elliptical path that the stroke rail travels. For both the manual and motorized embodiments, the method of varying the size of the elliptical path consists of increasing or decreasing the length of the stroke rail. ‘710 patent, col.2 ll. 47-51, col.6 ll.28-42. (“By extending or retracting the adjustment arm within the corresponding stroke rail, the effective length of the stroke rail is varied. By varying the effective length of the stroke rail, the stride over which the foot rails travel is varied.”) The C-channel, corresponding pin, and flared head do not change the length of the stroke rail. Therefore, they are not corresponding structure. See Cardiac Pacemakers, 296 F.3d at 1119 (“[C]orresponding structure need not include all things necessary to enable the claimed invention to work.”).

Next, Icon and Octane disagree as to the level of specificity required to describe the corresponding structure for the manual adjustment and the motorized adjustment alternatives. Icon proposes the corresponding structure for the manual adjustment embodiment be the following: “An arm with holes along a portion of its length that can be aligned with a pin and a hole in a stroke rail.” The Court construes the corresponding structure for the manual adjustment embodiment to be: An adjustment arm with holes along a portion of its length that can be aligned with a pin and a complementary hole in a stroke rail.

Icon proposes the corresponding structure for the motorized adjustment embodiment alternative be the following: “An electric motor driving a gear that engages teeth on a bar to move an adjustment arm.” The Court construes the corresponding structure for the motorized adjustment embodiment to be: An electric motor driving a gear that engages teeth on an elongated engagement bar to move an adjustment arm. The electric motor is mounted to the

stroke rail by a bracket, and the adjustment arm is connected to the elongated engagement bar by a rod.

3. “Means for coupling each crank arm to a corresponding stroke rail so as to enable free rotation of the axle.”

The parties agree that the function, “coupling each crank arm to a corresponding stroke rail so as to enable free rotation of the axle,” requires no construction, as the plain and ordinary meanings of the terms used to describe the function are sufficiently clear.

Again, the parties disagree as to the corresponding structure. Icon proposes the following construction for corresponding structure: “A pair of collars, each encircling a pin. Each pin projects from a crank arm and each collar is attached to a stroke rail.” Octane proposes the following construction:

The structure from the specification of the ‘710 patent that corresponds to this function is:

- 1) Pins 104 and 105 (pin 105 is not labeled in the Figures of the ‘710 patent);
- 2) Collars 106 and 107 (collar 107 is not labeled in the Figures of the ‘710 patent);
- 3) Spot welds that hold the two collars, referenced in 2) above, to the stroke rails 66 and 68; and
- 4) Nuts/washers at the end of pins 104 and 105.

Consistent with the reasoning set forth above, the Court adopts the following construction for the corresponding structure that performs the recited function of “coupling each crank arm to a corresponding stroke rail so as to enable free rotation of the axle”: A pair of collars, each encircling a pin. Each pin projects from a crank arm and each collar is attached to a stroke rail via spot welds or their equivalents. Nuts and washers, or the equivalents thereof, are positioned at the end of the pins.

IV. CONCLUSION

Based upon the foregoing, and all of the files, records and proceedings herein, **IT IS HEREBY ORDERED** that, in interpreting the '710 patent, the contested terms be construed in accordance with this Order.

BY THE COURT:

s/Ann D. Montgomery
ANN D. MONTGOMERY
U.S. DISTRICT JUDGE

Dated: December 22, 2010.