

Exhibit E

Exhibit E



US006647260B2

(12) **United States Patent**
Dusse et al.

(10) **Patent No.:** **US 6,647,260 B2**
(45) **Date of Patent:** **Nov. 11, 2003**

(54) **METHOD AND SYSTEM FACILITATING WEB BASED PROVISIONING OF TWO-WAY MOBILE COMMUNICATIONS DEVICES**

5,812,953 A * 9/1998 Griffith et al. 455/550

(List continued on next page.)

(75) Inventors: **Steve Dusse**, Woodside, CA (US);
Peter F. King, Half Moon Bay, CA (US);
Bruce V. Schwartz, San Mateo, CA (US);
Bruce K. Martin, Jr., Palo Alto, CA (US)

FOREIGN PATENT DOCUMENTS

EP	0 804 045	*	10/1997	H04Q/7/22
EP	1043905		10/2000		
EP	1091606		4/2001		
WO	95/15065		6/1995	H04Q/7/32
WO	97/13382	*	4/1997	H04Q/7/22
WO	97/28662		8/1997	H04Q/7/22
WO	98/58506	*	12/1998	H04Q/7/22
WO	99/07173		2/1999	H04Q/7/38
WO	01/39526	A1 *	5/2001	H04Q/7/06

(73) Assignee: **Openwave Systems Inc.**, Redwood City, CA (US)

OTHER PUBLICATIONS

(*) Notice: Subject to any disclaimer, the term of this patent is extended or adjusted under 35 U.S.C. 154(b) by 0 days.

“Mobile Management Server”, pp. 1–4, downloaded from <http://www.phone.com/products/mms/html> on Mar. 5, 2001.

(21) Appl. No.: **09/289,559**

Primary Examiner—William Trost

(22) Filed: **Apr. 9, 1999**

Assistant Examiner—Rafael Perez-Gutierrez

(65) **Prior Publication Data**

(74) *Attorney, Agent, or Firm*—Blakely, Sokoloff, Taylor & Zafman LLP

US 2002/0068554 A1 Jun. 6, 2002

ABSTRACT

(51) **Int. Cl.**⁷ **H04M 3/00**; G06F 15/16; H04L 9/00

A system and method for provisioning a two-way mobile communications device having a display screen and user interface that is initiated from the device to be provisioned. The device to be provisioned establishes a secure communications session with a provisioning server device. The subject communications path may utilize an intermediate server device. The user of the device is then presented with a plurality of input and choice screens, which may be used in conjunction with the user interface to provide user information, select device features and services. The user information and selected feature and service requests are then forwarded to the provisioning server device. The provisioning server device processes the received information and generates provisioning packages, registration requests, and notifications for the subject mobile device and for any associated server device providing services. The provisioning packages may comprise software modules, parameters and any required security information.

(52) **U.S. Cl.** **455/419**; 455/411; 709/219; 713/169

(58) **Field of Search** 455/419, 418, 455/414, 466, 411, 517, 410; 370/338, 352, 401, 402, 403, 404, 313; 709/218, 219, 223, 225, 227; 713/168, 169, 201

(56) **References Cited**

U.S. PATENT DOCUMENTS

5,485,505	A	*	1/1996	Norman et al.	455/419
5,586,260	A	*	12/1996	Hu	713/201
5,603,084	A	*	2/1997	Henry, Jr. et al.	455/419
5,673,322	A		9/1997	Pepe et al.		
5,719,918	A		2/1998	Serbetciouglu et al.	455/466
5,727,159	A	*	3/1998	Kikinis	709/246
5,732,074	A	*	3/1998	Spaur et al.	370/401
5,742,905	A		4/1998	Pepe et al.	455/461
5,809,415	A	*	9/1998	Rossmann	370/352

42 Claims, 9 Drawing Sheets

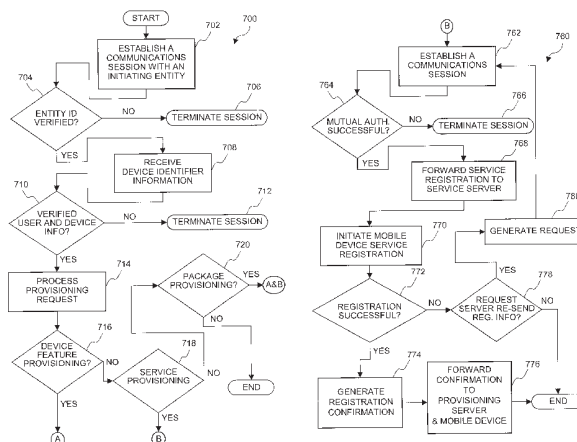

U.S. PATENT DOCUMENTS

5,841,764	A	11/1998	Roderique et al.	370/310	6,173,316	B1	*	1/2001	De Boor et al.	709/219
5,848,064	A	* 12/1998	Cowan	370/338	6,195,366	B1	*	2/2001	Kayashima et al.	370/401
5,875,394	A	* 2/1999	Daly et al.	455/419	6,195,546	B1	*	2/2001	Leung et al.	455/419
5,943,399	A	* 8/1999	Bannister et al.	379/88.17	6,195,547	B1	*	2/2001	Corriveau et al.	455/419
5,956,636	A	* 9/1999	Lipsit	455/419	6,233,608	B1	*	5/2001	Laursen et al.	709/217
6,031,830	A	* 2/2000	Cowan	370/338	6,253,326	B1	*	6/2001	Lincke et al.	713/168
6,049,821	A	* 4/2000	Theriault et al.	709/203	6,275,693	B1	*	8/2001	Lin et al.	455/414
6,065,120	A	* 5/2000	Laursen et al.	713/201	6,295,291	B1	*	9/2001	Larkins	709/219
6,138,009	A	* 10/2000	Birgerson	455/419	6,343,323	B1	*	1/2002	Kalpio et al.	709/217
6,138,158	A	* 10/2000	Boyle et al.	709/219	6,421,781	B1	*	7/2002	Fox et al.	713/201
6,148,405	A	* 11/2000	Liao et al.	713/201	2001/0032254	A1	*	10/2001	Hawkins	709/219
6,151,628	A	* 11/2000	Xu et al.	713/201	2002/0068554	A1	*	6/2002	Dusse	455/419

* cited by examiner

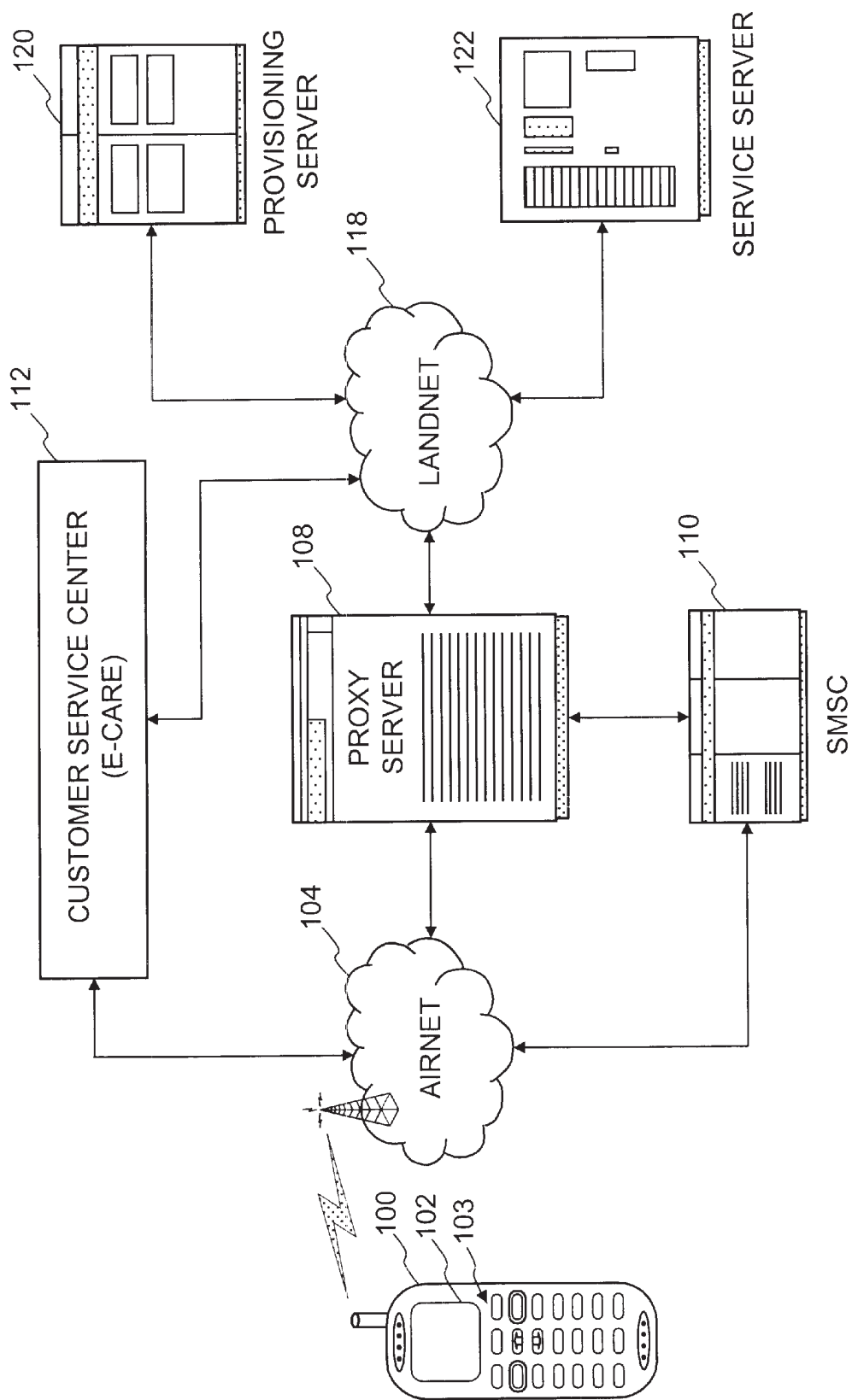

Fig. 1

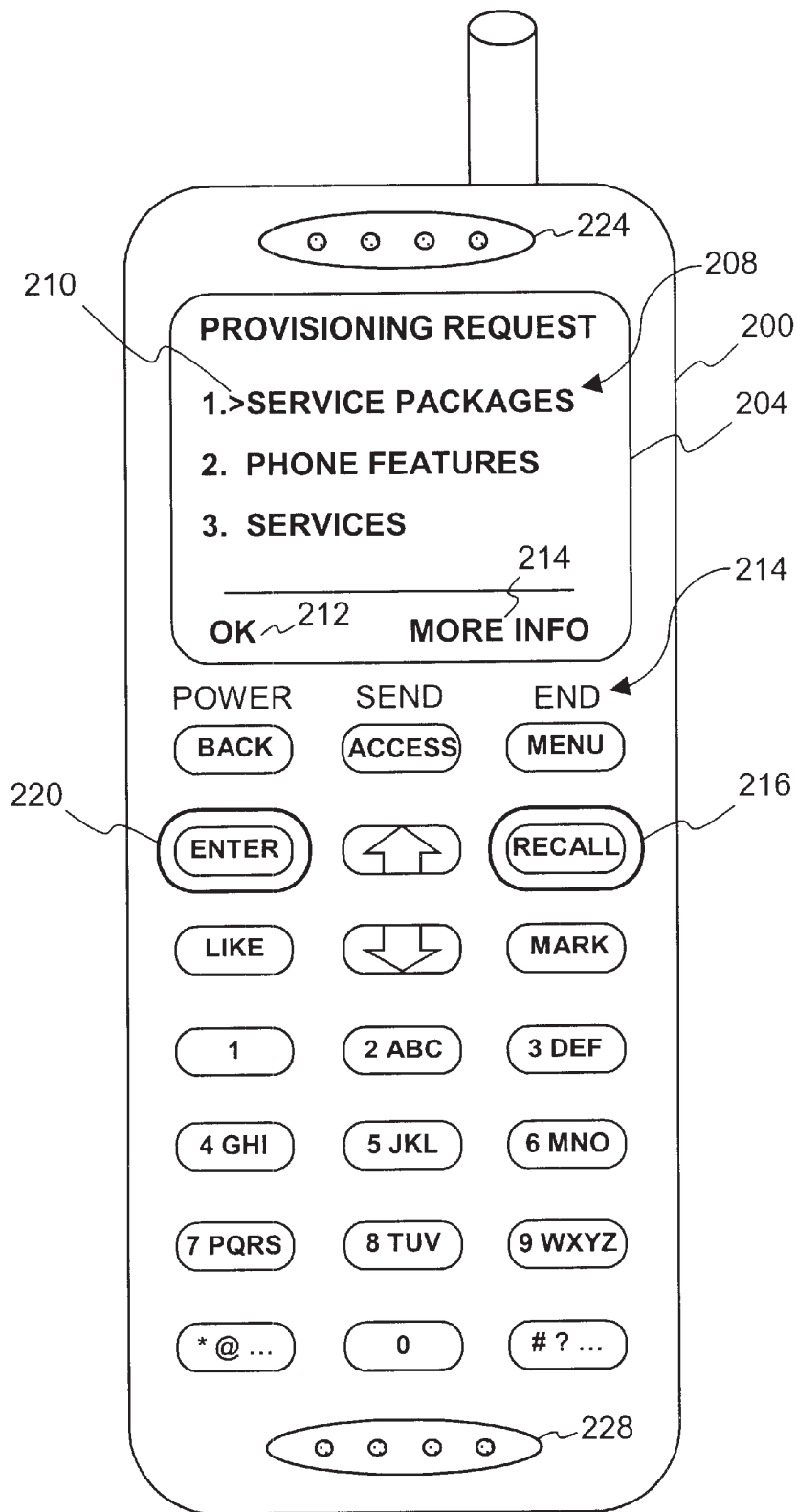

Fig. 2

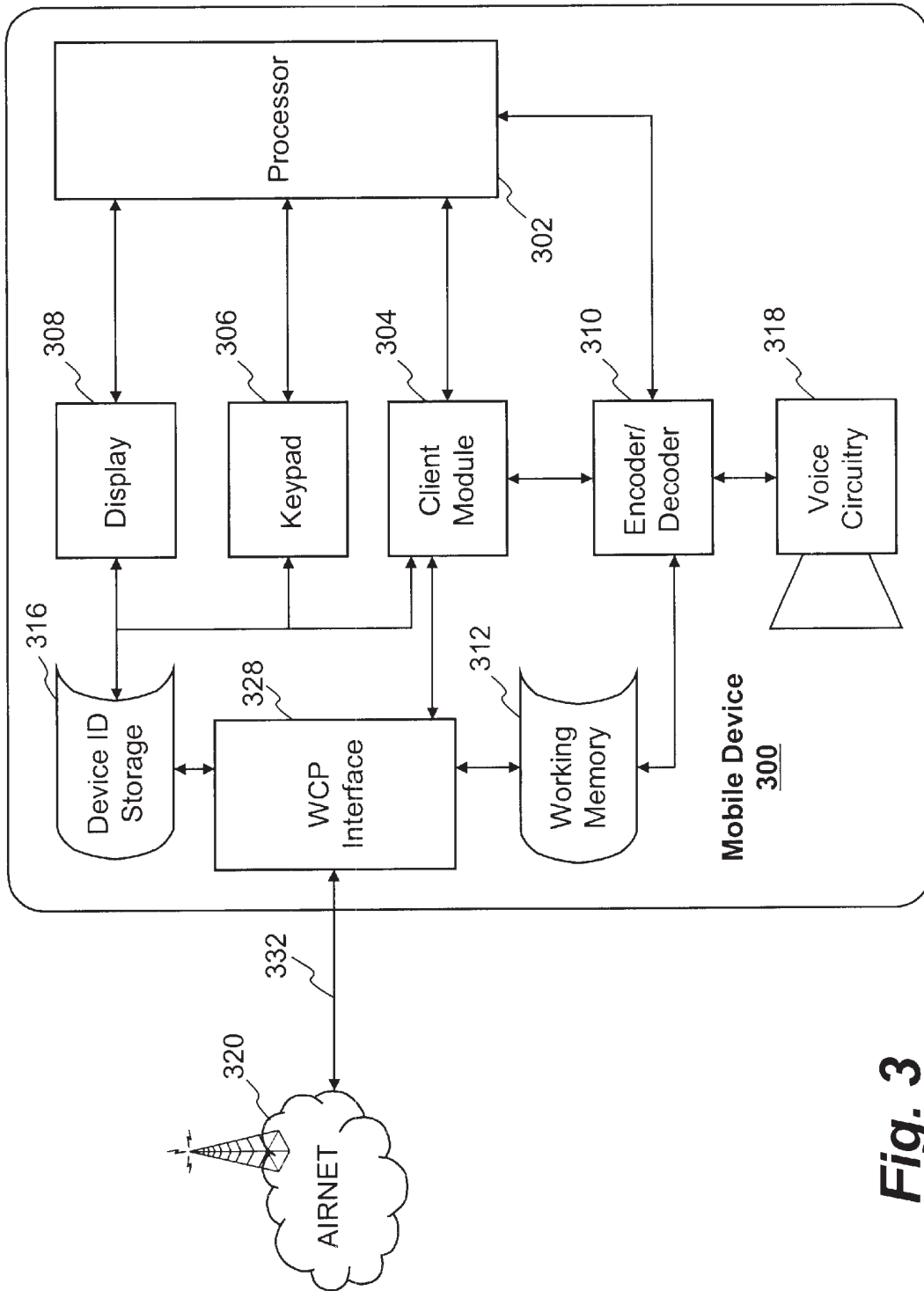

Fig. 3

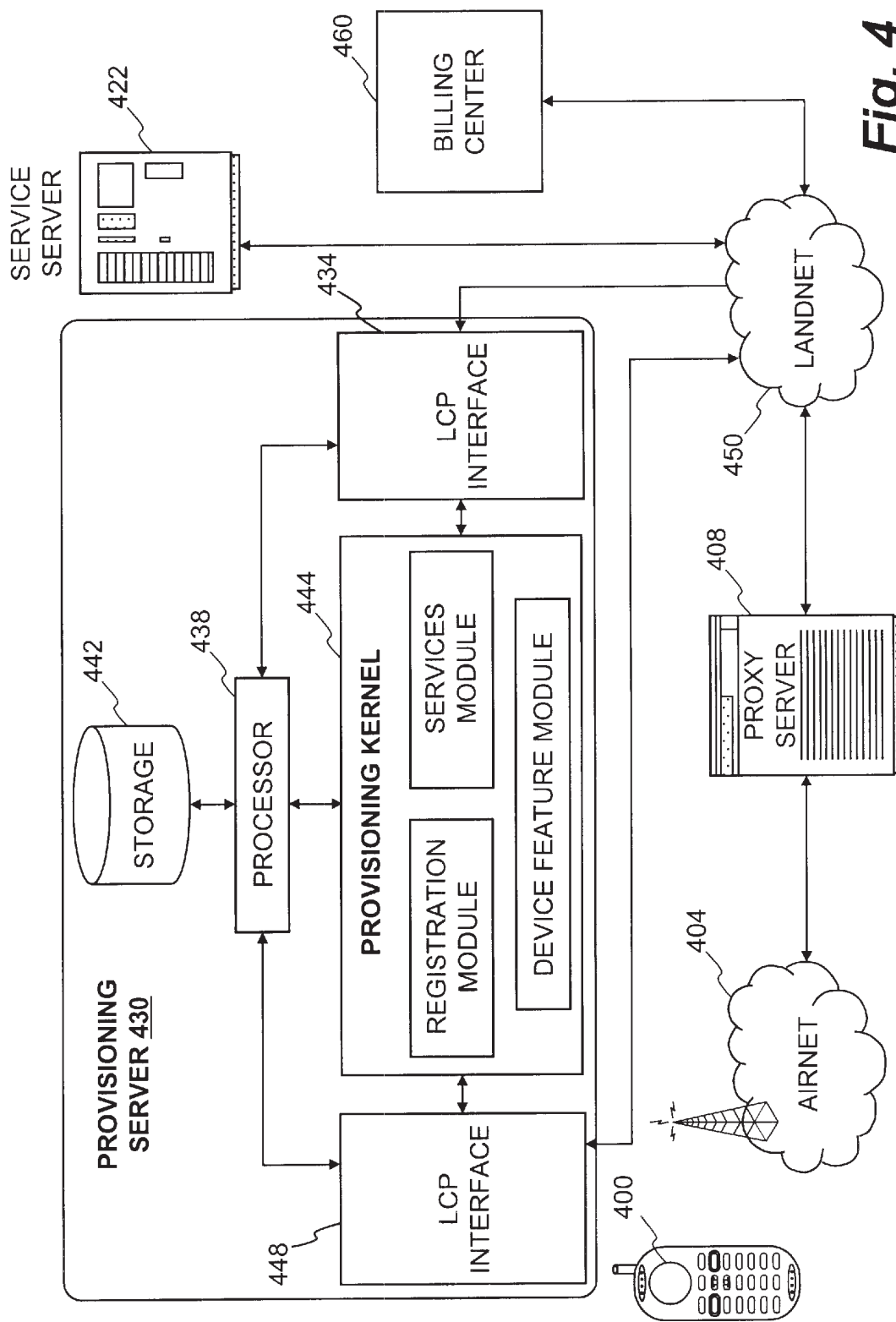

Fig. 4

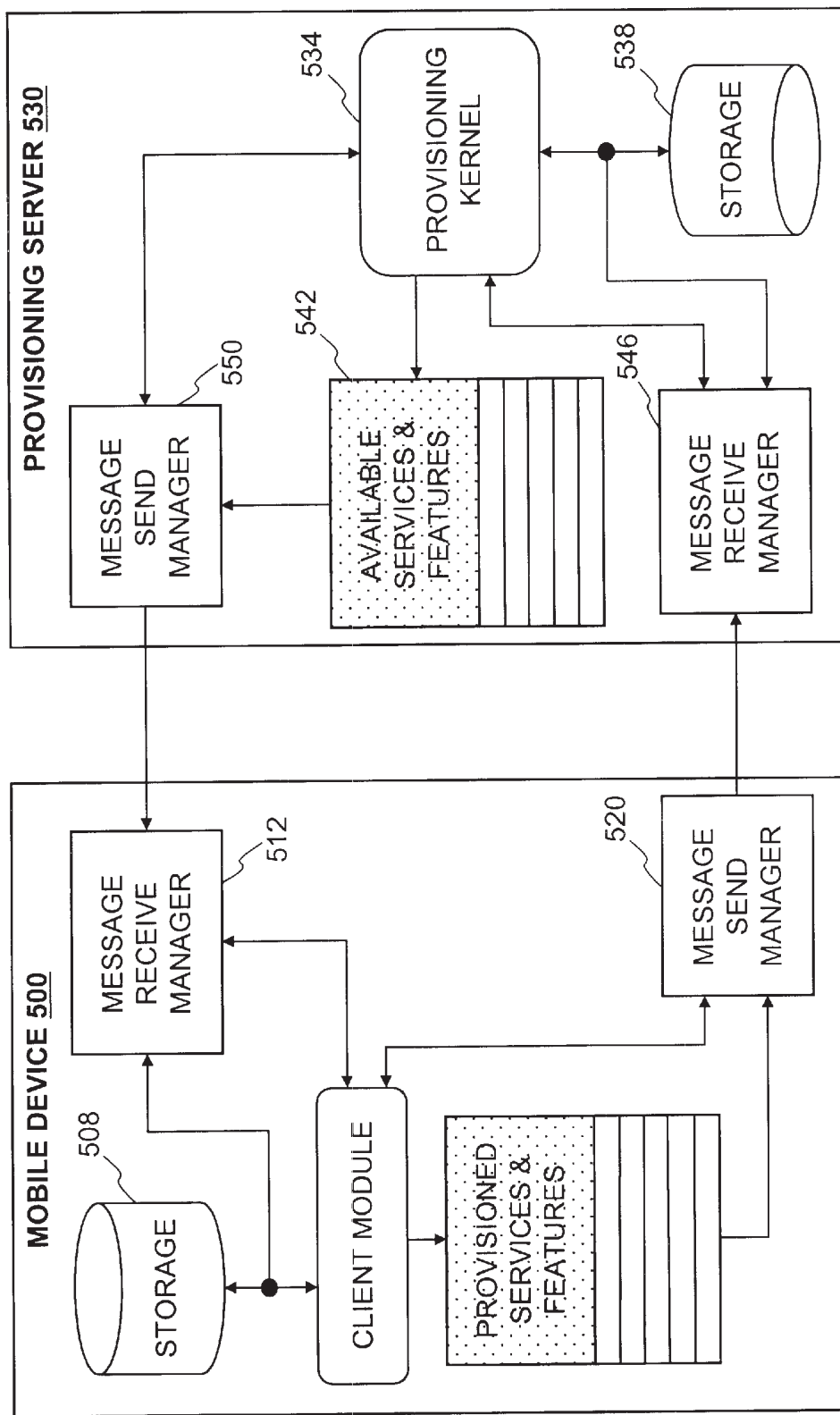

Fig. 5

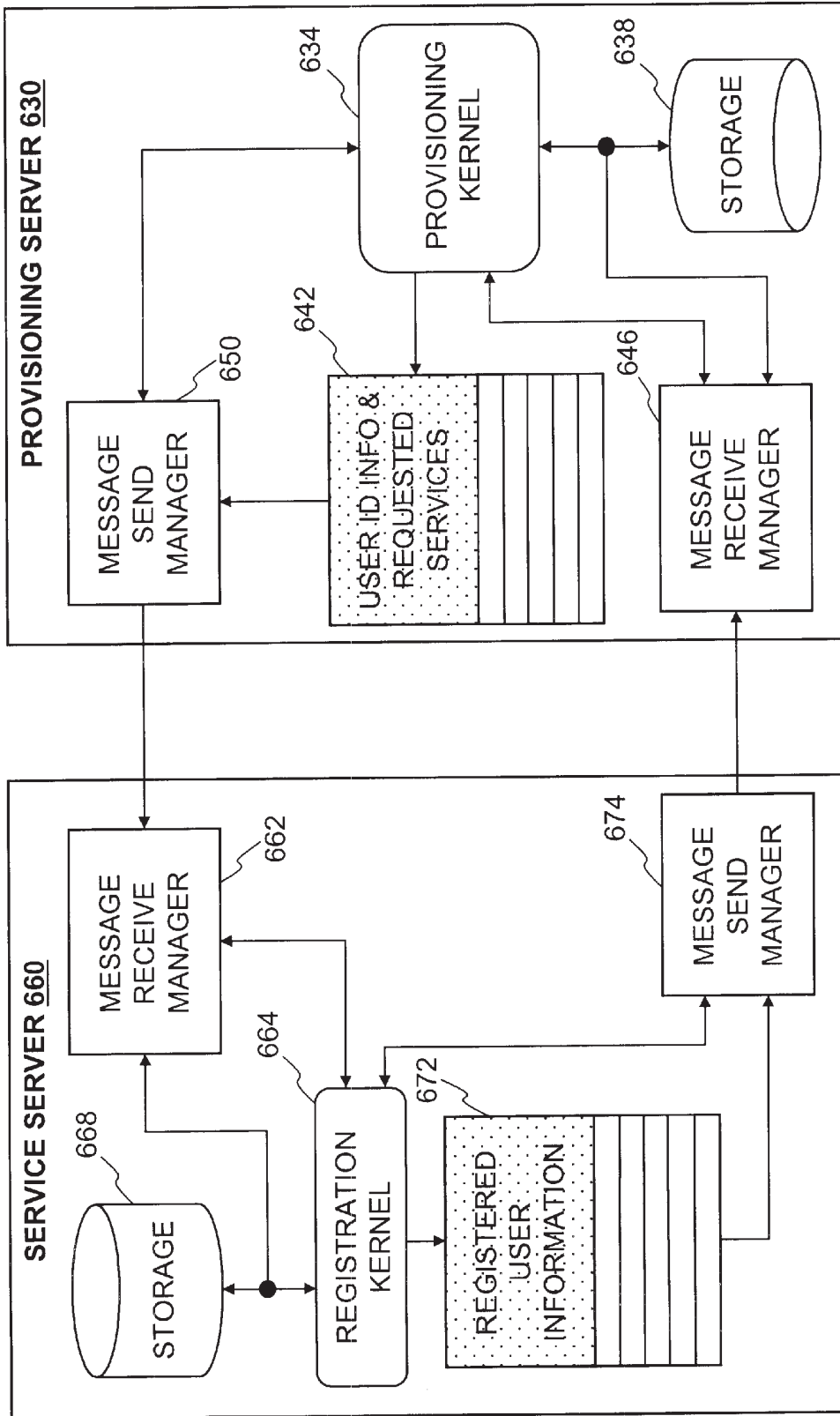

Fig. 6

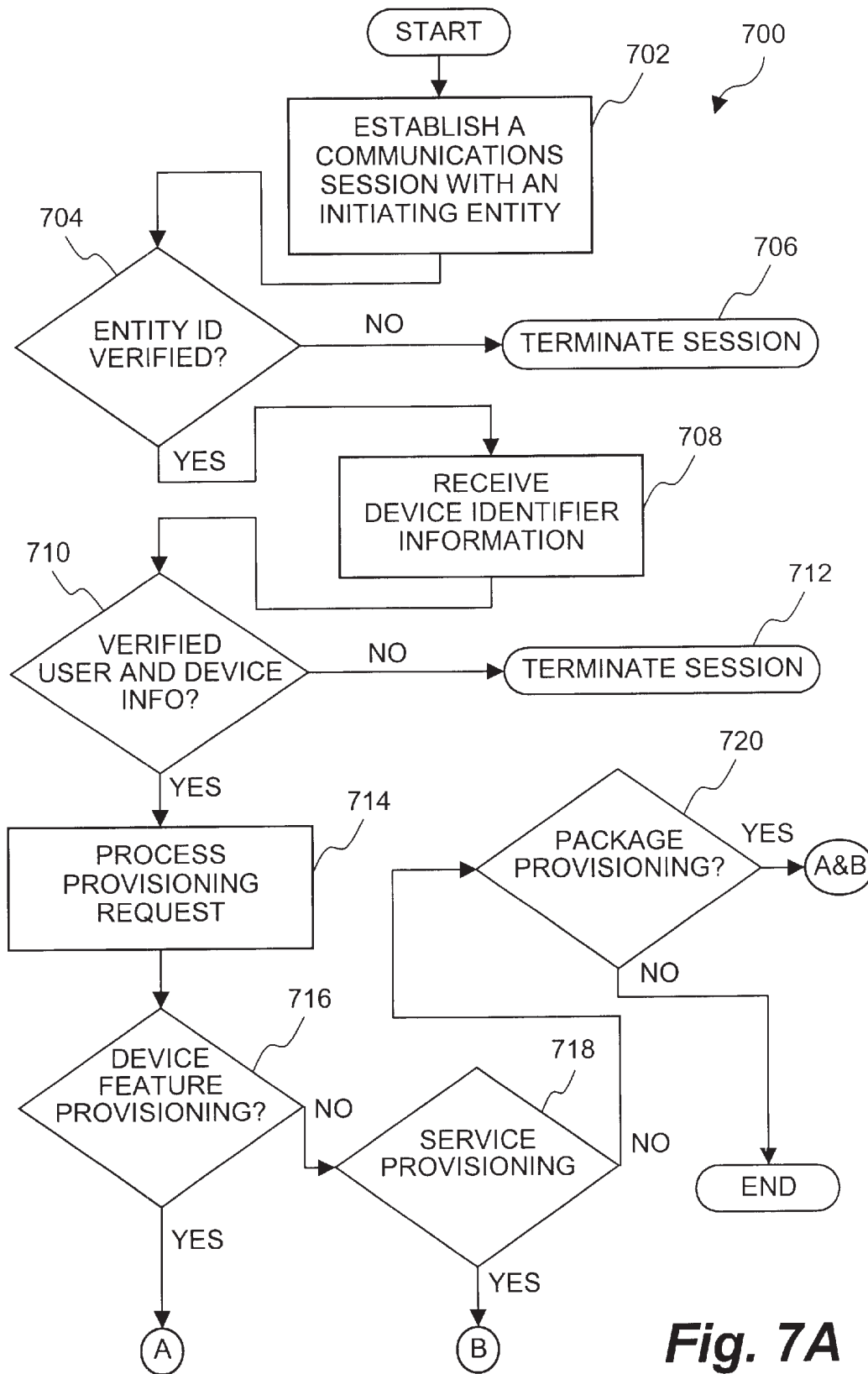

Fig. 7A

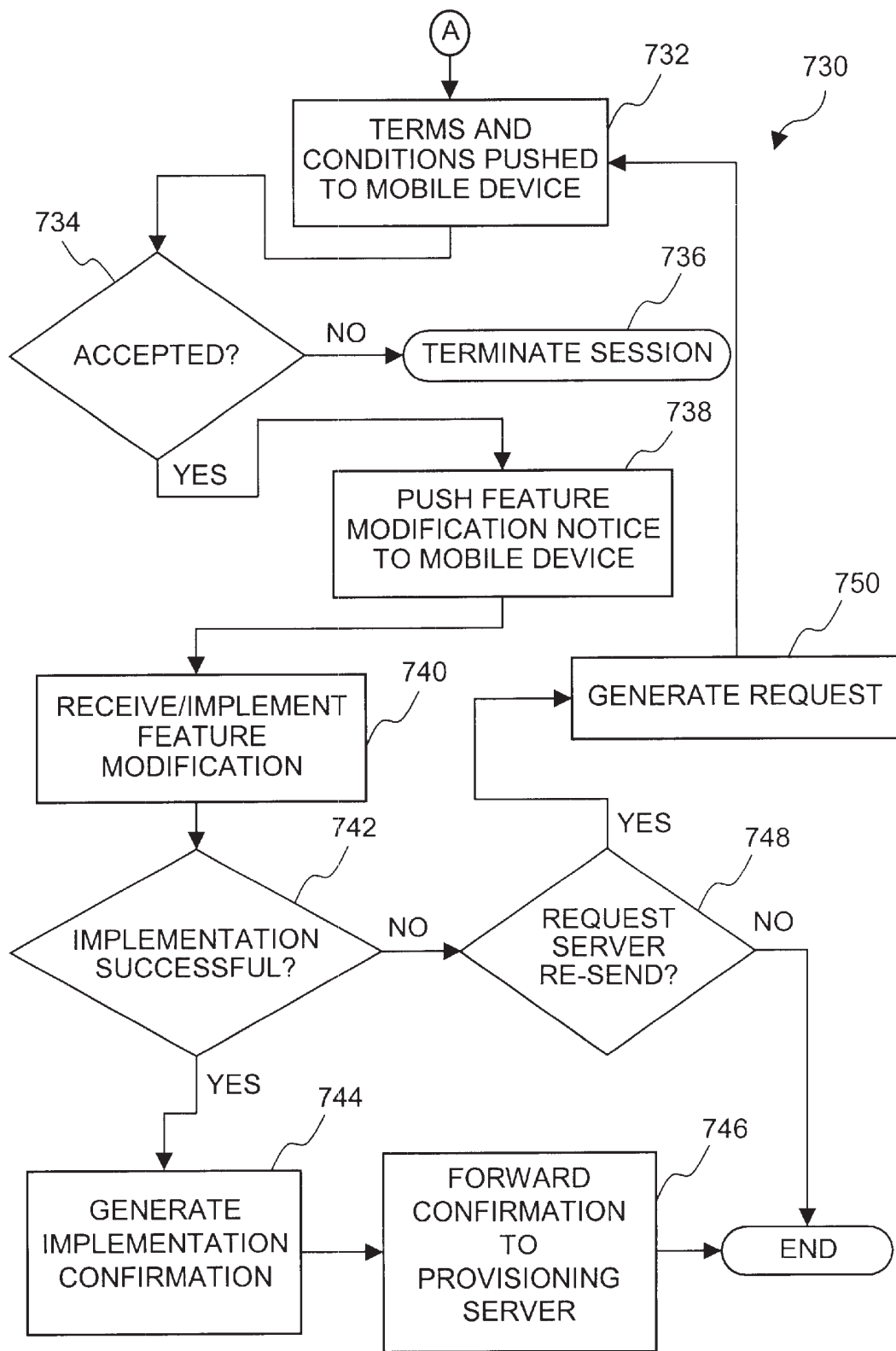

Fig. 7B

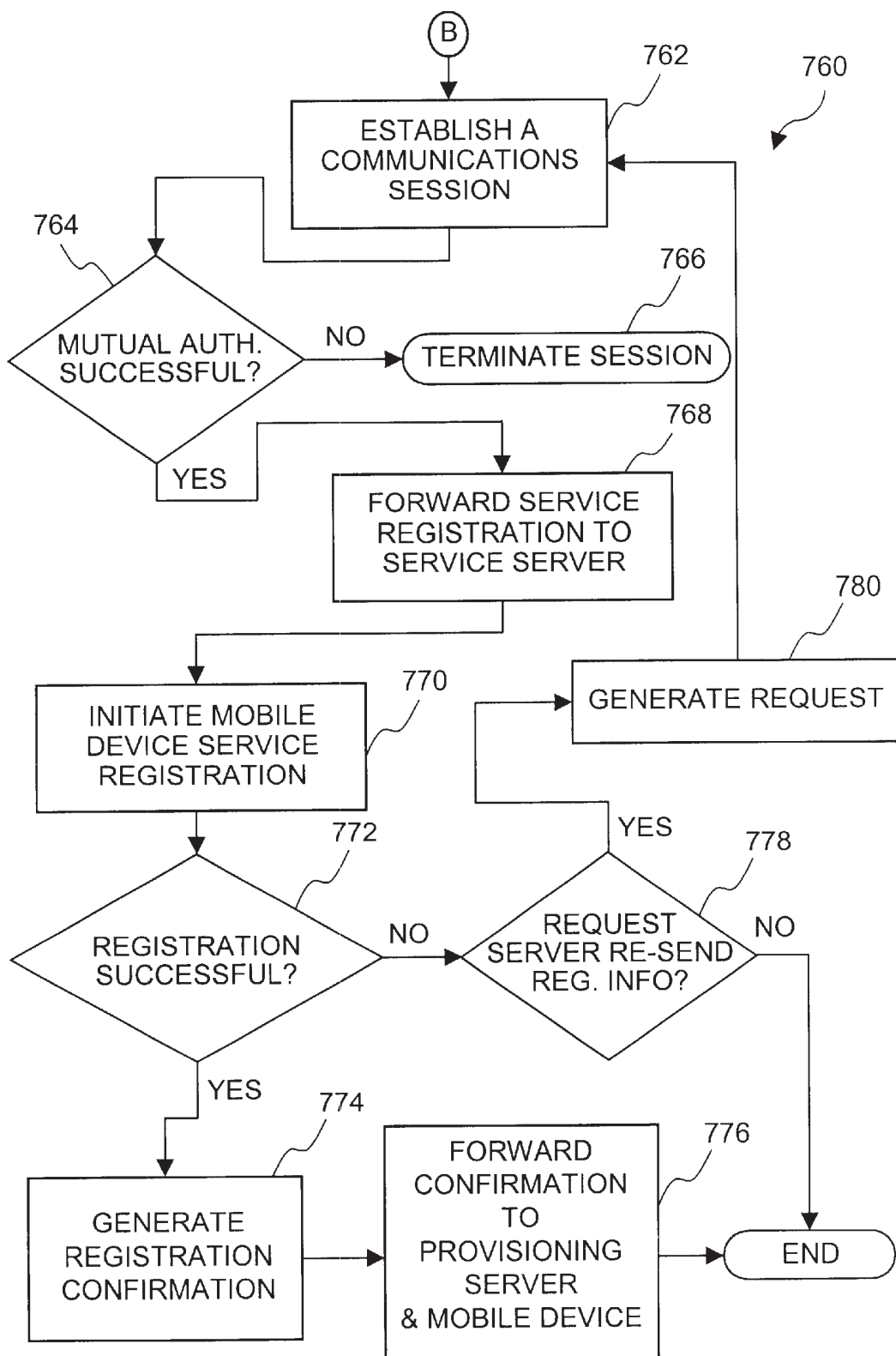

Fig. 7C

METHOD AND SYSTEM FACILITATING WEB BASED PROVISIONING OF TWO-WAY MOBILE COMMUNICATIONS DEVICES

BACKGROUND OF THE INVENTION

1. Field of the Invention

The present invention relates to two-way mobile communication devices and, more particularly, to a method and system for provisioning the features and services available to the two-way mobile communication devices.

2. Description of the Related Art

For persons and businesses requiring instant access to information, the Internet and Intranets have provided a vehicle for near real-time delivery of information from an enormous number of sources. For many of those same individuals, two-way mobile communication devices (e.g., cellular phones, two-way pagers, Personal Digital Assistants (PDAs), and handheld computing devices) have provided a means for communicating irrespective of locality. It was only natural for these two exploding mediums to come together in a manner such that two-way mobile communication devices have become one of a plurality of entry vehicles into the Internet and Intranets.

The current generation of two-way mobile communication devices have microprocessors, information storage capability, and run one or more software applications. Examples of software applications used in these devices include micro-browsers, address books, and email clients. Additionally, this generation of two-way mobile communication devices has access to a plurality of services via the Internet and Intranets.

Before a consumer can use one of these devices, a number of parameters must be provisioned into the device in order to enable communication services and applications and in order to distinguish the device from others within the communications network. In addition to provisioning the two-way mobile communication device, it is also necessary to provision network elements in the communications network which are responsible for effecting mobile communications services and applications (e.g., billing plan, voice mail, call forwarding, email, information services etc.).

As with any other service-related industry, consumers demand convenience in the provisioning process. From the consumer's perspective it would be preferable to be able to walk into a store and select from an assortment of devices and services without being pressured by a sales person pushing a particular device or service.

Unfortunately, there are other concerns that effect the manner and procedures involved in provisioning the two-way mobile communications devices and services. Fraud is a \$1 billion dollar problem for the telecommunications industry. In 1997, about \$600 million was lost due to cloning fraud and another \$400 million was lost from subscription fraud (Corsair Communications).

Thus, there exists a need for a method and system for provisioning two-way mobile communications devices and services that is convenient for consumers and secure for the service providers and device manufacturers.

SUMMARY OF THE INVENTION

In view of the above, it is one of the objects in the present invention to provide a method and system for provisioning two-way mobile communications devices and services that provides convenience for consumers without compromising the carrier's and service provider's sensitive provisioning information.

According to one aspect of the present invention, a system and method for provisioning a two-way mobile communications device having a display screen and user interface that is initiated from the device to be provisioned. The device to be provisioned establishes a secure communications session with a provisioning server device. The subject communications path may utilize an intermediate server device. The user of the device is then presented with a plurality of input and choice screens, which may be used in conjunction with the user interface to input user information and select device features and services. The user information and selected features and services are then forwarded to a provisioning server device. The provisioning server device processes the received information and generates provisioning content and notifications for the subject mobile device and for any associated server device providing service(s). The provisioning packages may be comprised of software modules and any required security information.

According to another aspect of the present invention, a system and method for provisioning a two-way mobile communications device having a display screen and user interface that is initiated from a remote server device. The remote server device establishes a secure communications session with a provisioning server device and provides the provisioning server with user information and features and services for which the two-way mobile communications device is to be provisioned for. The provisioning server device processes the received information and generates provisioning packages and notifications for the two-way mobile communications device and for any associated server device providing services. Preferably the provisioning packages may comprise software modules, parameters, and any required security information. User information may be provided to the remote server device through a system utilizing a telephone and an Interactive Voice Response Unit (IVRU) or from a user to a representative who forwards the information to the provisioning server device.

The advantages of the invention are numerous. Different embodiments or implementations may yield one or more of the following advantages. One advantage of the present invention is that the user of a two-way mobile communications device can initially provision features and services without having to go to a retail establishment. Another advantage of the present invention is that the user can change the features and services associated with their two-way mobile communications device after the initial provisioning. Still another advantage of the present invention is that the carrier can remotely change the features and services associated with a two-way mobile communications device and provide a system for notifying the user of the changes made.

Other aspects and advantages of the invention will become apparent from the following detailed description taken in conjunction with the accompanying drawings, which illustrate by way of example, the principles of the invention.

BRIEF DESCRIPTION OF THE DRAWINGS

The present invention will be readily understood by the following detailed description in conjunction with the accompanying drawings, wherein like referenced numerals designate the structural elements, and in which:

FIG. 1 illustrates a communications system, which may be utilized to practice the present invention;

FIG. 2 illustrates a schematic of a two-way mobile communications device according to an embodiment of the present invention;

3

FIG. 3 illustrates a block diagram of the principle components of an exemplary two-way mobile communications device;

FIG. 4 schematically illustrates the relationship between the provisioning server and the other system components;

FIG. 5 schematically illustrates the mechanism for exchanging information between the two way mobile communications device and the provisioning server;

FIG. 6 schematically illustrates the mechanism for exchanging information between a service server and the provisioning server;

FIG. 7A is a flow chart, which describes a two-way mobile communications device request for provisioning;

FIG. 7B is a flow chart, which describes the provisioning of the features requested by the two-way mobile communications device; and

FIG. 7C is a flow chart, which describes the provisioning of the services requested by the two-way mobile communications device.

DETAILED DESCRIPTION OF THE INVENTION

The invention pertains to systems and methods, which enables the provisioning of a two-way mobile communications device having a display screen and user interface. According to one embodiment of the present invention, a provisioning transaction is initiated by a request to a provisioning server device from the two-way mobile communications device to be provisioned. The provisioning request may be forwarded through a proxy server device, which acts as a trusted third party in authenticating the principle participants. The provisioning request includes information input by the user using the user interface and device identification information resident in the mobile communication device. User input information may include personal identification information and financial information (e.g., credit card numbers, bank account numbers etc.) requiring verification by an outside processing entity (e.g., TRW). Upon verification of the user information and the device information, the provisioning server device processes the provisioning request. This processing may require the delivery of software modules and registration information to the provisioned two-way mobile communications device and any server devices (e.g., service servers) providing service. During the process, the user of the device may receive notifications relating to the state of processing and the services and features provisioned. These notifications may be pushed to the provisioned device through a narrow-band data channel (e.g., Short Message Service (SMS)).

The two-way mobile communication device, also referred to as two-way interactive communication devices, wireless client devices, and mobile devices, include but are not limited to personal digital assistants, palm-sized computing devices, cellular phones, two-way pagers, and wireless capable remote controllers. Such devices typically have significantly less memory and processing capability than is found in desktop and laptop computers. These mobile devices typically have a small display screen and a keypad with a reduced character set, as opposed to the full function keyboards and monitors associated with desktop or laptop computers.

Embodiments of the invention are discussed below with reference to FIGS. 1-7C. However those skilled in the art will readily appreciate that the detailed description given herein with respect to these figures is for exemplary pur-

4

poses as the invention extends beyond the embodiments discussed below.

To facilitate a description of the present invention, it is deemed necessary to recite some of the features of a communications system in which the invention may be practiced. Referring to FIG. 1 a block diagram of a typical communications system according to one embodiment of the present invention is displayed. Mobile device **100** (e.g., a cellular telephone, a two-way pager, a personal digital assistant, or a palm-sized computer) receives phone calls through a voice communications channel and hypermedia information (e.g., Hyper Text Markup Language (HTML) documents, Compact Hypertext Transport Protocol (cHTML) documents, Extensible Markup Language (XML) documents, Handheld Device Markup Language (HDML) documents, or Wireless Markup Language (WML) documents) from remote server devices through broad-band and narrow-band (e.g., SMS) data communications channels which may include proxy server device **108** and Short Message Service center (SMSC) **110**. Mobile device **100** has a display **102** and a user interface **103**. Additionally, mobile device **100** may have a micro-browser (e.g., a micro-browser from Unwired Planet, Inc. 800 Chesapeake Drive, Redwood City, Calif., 94063) stored in a local memory which enables it to process hypermedia information received from remote server devices.

Information is exchanged between mobile devices **100** and remote server devices (e.g., provisioning server **120** and service server **122**) using airnet **104** and landnet **118**. Airnet **104** may be, for example, a cellular digital packet data network (CDPD), a Global System for Mobile (GSM) network, a Code Division Multiple Access (CDMA) network, a Time Division Multiple Access (TDMA) network, a Personal Digital Cellular (PDC) network or a Personal Handy-phone System (PHS) network. The communications protocols used by airnet **104** may, for example, be Wireless Access Protocol (WAP) or Handheld Device Transport Protocol (HDTP). Landnet **118** is a land-based network that may be the Internet, an Intranet or a data network of any private network. Typically the communication protocol supporting landnet **118** may be Transmission Control Protocol (TCP/IP), Hypertext Transport Protocol (HTTP), or Secure Hypertext Transport Protocol (sHTTP).

The data communication path between airnet **104** and landnet **118** may be bridged by proxy server device **108**, which coordinates the exchange of information on the wide-band and narrow-band communications channels providing communication with mobile device **100**. The narrow-band channel may be used for the exchange of content requiring limited bandwidth transmission services (e.g., Short Message Service (SMS)) and the wide-band channel is used for all other exchanges. An additional server device (e.g., Short Message Service Center (SMSC)) **110** generally coordinates communications on the narrow-band channel.

Proxy server device **108** and SMSC **110** may be, for example, a SPARC workstation from Sun Microsystems, Inc. (<http://www.sun.com>). As previously stated proxy server device **108** acts as a bridge between airnet **104** and remote devices connected by landnet **118**. It should be pointed out, however, that the functions of proxy server device **108** and SMSC **110** may be performed by network server devices connected to landnet **118** with hardware well known in the art providing the connection between airnet **104** and landnet **118**.

According to one embodiment of the present invention, mobile device **100** is initially unprovisioned when obtained

(e.g., at a retail store or via the mail) by a user. When mobile device **100** is initially turned on a communications session is established with proxy server device **108** and a provisioning application is activated which displays scripts on display screen **102** of mobile device **100** prompting the user to input provisioning related information via user interface **103**. The provisioning related information and pre-stored device identification information (also referred to as a provisioning request herein) are forwarded to provisioning server **120** via proxy server device **108** using a secure communications session. The secure communications session is facilitated by a previously stored uniform resource identifier (URI) associated with provisioning server **120** and authentication services provided by proxy server device **108**.

The provisioning request contains information relating to the mobile device features and services desired by the user. Additionally, the provisioning request may contain the accounting information (e.g., credit card information, bank-cards etc.) used to establish a user account. The provided accounting information can be verified by applications resident on provisioning server **120** or by outside financial services, which are accessible via landnet **118** (e.g., TRW). Once the information in the provisioning request is verified, provisioning content is forwarded to mobile device **100** and provided to any network element (e.g., service server **122**) providing service to mobile device **100** as a result of the services requested. Additionally, the user may be provided with periodic status updates relating to the processing of the provisioning request and information relating to the features and services actually provisioned.

Mobile device **100** is pre-provisioned with the content required to communicate with an automated Customer Service Center (E-CARE) **112** via data and voice communications channels. The E-CARE center **112** may provide assistance to the user during the provisioning process. One embodiment of an E-CARE center is disclosed in U.S. patent application Ser. No. 09/093,944 entitled "Visual Interface to Mobile Account Services" and is hereby incorporated by reference.

With reference now to FIG. **2**, mobile device **200** (e.g. a cellular telephone, a two-way pager, a personal digital assistant, or a palm-sized computer) comprises a display screen **204**, a user interface **216**, a speaker **224**, and microphone **228**. Display screen **204** contains hyper media information **208**, a hypermedia selection identifier ">" **210** and softkey identifiers **212** and **214**. User interface **214** has function keys (e.g., "MENU", "BACK"), alphanumeric keys, and navigation keys (↑ and ↓). Additionally, function keys **216** and **220** are utilized for soft key inputs.

Hypermedia information **208** is illustrative of the type of an entry screen relating to the provisioning application. Hypermedia information **208** is comprised of a plurality of selectable identifiers corresponding to selections available in the provisioning application. It is important to note that each of the identifiers is associated with a Uniform Resource identifier (URI) and the associated URIs may be for the same provisioning server device or different provisioning server devices. The navigation keys (↑ and ↓) are used to navigate the list of selectable identifiers where hypermedia selection identifier ">" **210** indicates the selected item. The provisioning application allows the user to pick and chose desired device features and services (selections 2 and 3 on screen **204**) or to select predetermined device and service configurations (selection 1 on screen **204**).

Referring now to FIG. **3**, a more detailed description of mobile device **300**, which may be mobile device **100** of FIG.

1, is provided. Mobile device **300** includes memory **312** that stores data and/or software for performing many of the functions of the device **300** when executed by a processor **302**. Mobile device **300** also includes a Wireless Control Protocol (WCP) interface **328** that couples to a carrier network via airnet **320** to receive incoming and outgoing signals. Device identifier (ID) storage **316** stores and supplies a device ID to WCP interface **328** for the purpose of identifying mobile device **300** to outside entities (e.g., proxy server device **108** of FIG. **1**). The device ID identifies a specific code that is associated with mobile device **300** and directly corresponds to the device ID in the user account typically provided in an associated proxy server device (e.g., **108** of FIG. **1**). In addition, mobile device **300** includes a client module **304** that performs many of the processing tasks performed by mobile device **300** including: establishing a communication session with a proxy server device via airnet **320**, operating and maintaining a resident address book, displaying information on a display screen **308** thereof, and receiving user input from keypad **306**. The client module **304** is coupled to WCP interface **328** for the establishment of a communication session and the requesting and receiving of data. The device **300** further includes voice circuitry **318** for inputting and outputting audio, and an encoder/decoder **310** coupled between processor **302** and voice circuitry **318** for encoding and decoding audio signals.

FIG. **4** schematically illustrates the relationship between the provisioning server **430**, which may correspond to provisioning server **120** of FIG. **1**, and the other components of the communications system. It is important to note at this point that the functions of provisioning server **430** may be incorporated in proxy server device **408** or another device with direct or indirect access to airnet **404**. Provisioning server **430** is comprised of Land Control Protocol (LCP) interfaces **434** and **448**, processor **438**, storage device **442** and a provisioning kernel **444** comprised of a plurality of software modules. More specifically, the provisioning kernel is comprised of a Registration Module, a Services Module, and a Device Feature Module.

The Registration Module coordinates the processing of the provisioning request in terms of verifying the request components (e.g., device identification information, accounting and information) and matching the requested device features and services with available features and services. It is important to note at this point that the provisioning content required to process the request may be resident on the provisioning server receiving the request or on any server device accessible via landnet **450**.

Provisioning content relating to mobile device features are retrieved from the Device Feature Module. The provisioning content relating to requests for device features takes the form of software modules, which modify the resident features of mobile device **400** or activation information required to initialize previously installed non-operational applications. Once the features of mobile device **400** have been provisioned, a notification is provided to billing center **460**. The provisioned features are also displayed on the display of mobile device **400**.

Provisioning content relating to services are retrieved from the Services Module. The provisioning content relating to requests for services takes the form of a request to register a new user. This request is comprised of the URI of service server providing the service (e.g., service server **422**) and registration information relating to the user of mobile device **400**. Once mobile device **400** has been registered, a notification is provided to billing center **460**. Additional notifications and information required to access the provisioned

services (e.g., passwords) are sent to mobile device **400** through a narrow band channel (e.g., an SMS message).

FIG. 5 schematically illustrates the exchange of provisioning content between mobile device **500**, which may be mobile device **100** of FIG. 1 and provisioning server **530**, which may be provisioning server **120** of FIG. 1. Mobile device **500** generates a provisioning request which is then forwarded to provisioning server **530** via the message send manager **520** resident in mobile device **500** and the message receive manager **546** resident in provisioning server **530**. As previously stated, information relating to the mobile device (e.g., a pre-stored device identification number) and information required to establish a user account (e.g., credit card information) are verified prior to processing the provisioning request if the phone has not previously been provisioned. The information verification process can be performed by applications resident in provisioning kernel **534** using information stored in storage device **538**. Additionally the verification process can be performed by outside entities accessible through a landnet (e.g., the Internet or an Intranet).

The provisioning request received from mobile device **500** contains requests for specific device features and services. Applications resident within provisioning kernel **534** match the requested features and services with available features and services listed in database **542**. The content relating to the features and services listed in database **542** need not be resident on provisioning server **530**. The content may be resident on a remote server device accessible through a landnet (not shown). If requested features or services are not resident within database **542** or if there is some conflict with the features or services requested then a notification message (e.g., SMS message) is sent to mobile device **500**. Content relating to matching device features and services is forwarded to the requesting mobile device via message send manager **550** and message receive manager **512** and is stored in storage **508**. The content may be comprised of software modules and information required to communicate with limited access commercial server devices. Additionally, mobile device **500** is registered with the limited access server devices providing requested services and registered with a billing entity.

FIG. 6 schematically illustrates the exchange of information between service server **660**, which may be service server **122** of FIG. 1 and provisioning server **630**, which may be provisioning server **120** of FIG. 1. Provisioning server **630** forwards a user registration request to service server **660** via a message send manager **650** and message receive manager **662**. Provisioning server **630** and service server **660** are connected by a landnet (e.g., the Internet or an Intranet) which is not shown in the drawing. Mutual authentication of the participants involved in the transaction are by methods well known in the art. User information and information relating to requested services is stored in database **642**. The information is forwarded to service server **660** where it is stored in storage **668** and used to register the user for the requested services. Acknowledgments regarding the user's registration and provisioning content **672** (e.g. passwords security information, etc.) are forwarded to provisioning server **630** by a registration kernel **664** via message send manager **674** and message receive manager **646**. Provisioning server **630** forwards the provisioning content and any related notifications to the requesting mobile device.

Once the initial device features and services are provisioned, account information is registered with a billing entity. Changes to the features or services may be initiated at any time by the user or by an authorized administering entity using the systems and methods described above.

Corresponding changes to the billing account will be made concurrently. Additionally, offers relating to feature and service upgrades can be forwarded to the device user via a narrowband channel (e.g., an SMS message).

It is important to note at this point that the exchange of information between the mobile device requesting provisioning (e.g., **100** of FIG. 1), the provisioning server (e.g., **120** of FIG. 1) and the service server (e.g., **122** of FIG. 1) is conducted using mutually exclusive secure communications sessions. In effect the provisioning server acts as a trusted third party in registering the requesting mobile device with the service server providing the requested service.

FIG. 7A illustrates a process flow chart which describes the process **700** used by a mobile device (e.g., mobile device **100** of FIG. 1) to generate a provisioning request. At **702** a secure communications session is established between the requesting mobile device and the provisioning server (e.g., provisioning server **120** of FIG. 1). At **704** the identity of both participants is mutually authenticated. If mutual authentication fails the session is terminated at **706**. If mutual authentication is successful, the device identification information and user information are forwarded, at **708**, to the provisioning server where they are verified at **710**. If either the device information or the user information fails the verification process then the session is terminated at **712**. If the verification process is successful then the provisioning request is processed at **714**. Feature provisioning (**716-A**) is described in FIG. 7B, service provisioning (**718-B**) is described in FIG. 7C and package provisioning provisions, at **720**, a predetermined group of features and services using the process described in FIGS. 7B and 7C.

Referring now to FIG. 7B, the process **730** of feature provisioning is described. Upon processing of the provisioning request, terms, conditions, and related information notifications are pushed to the requesting mobile device using the narrowband channel (e.g., an SMS message) at **732** for approval by the user prior to implementation. Additionally this information may forwarded to the user through a predetermined email address or facsimile number. If the user declines at **734**, then the session is terminated at **736**. If the user accepts then, at **738**, a notification to that effect is forwarded to the requesting mobile device through a narrowband channel and the provisioning content is forwarded to the mobile device via a wideband channel. The provisioning content is provisioned at **740** and a determination is made at **742** as to whether the provisioning content was implemented successfully. If the implementation fails then the user has the option of requesting a retransmission at **748** via a request generated at **750**. If the implementation is successful then a confirmation message is generated at **744** and forwarded to the provisioning server at **746**.

Referring now to FIG. 7C the process **760** utilized by the provisioning server (e.g., **120** of FIG. 1) to register a requesting mobile device (e.g., **100** of FIG. 1) with a server device providing service (e.g., **122** of FIG. 1) is described. At **762** a communications session is established between the provisioning server and the service server where the two are subjected to a mutual authentication process at **764**. If the mutual authentication process fails then the session is terminated at **766**. If mutual authentication is successful then user registration information is forwarded to the service server **768**. The registration request is processed at **770** and if the device is successfully registered (**772**) then a registration confirmation notification is generated at **774** and forwarded to the provisioning server at **776**. If registration fails (**772**) due to corrupted registration information or

missing information then the user has the option of re-sending a registration request at 778. This is done by the service server which generates a request for the missing or corrupted information at 780.

The present invention has been described in sufficient detail with a certain degree of particularity. It is understood to those skilled in the art that the present disclosure of embodiments has been made by way of example only and that numerous changes in the arrangement and combination of parts as well as steps may be resorted to without departing from the spirit and scope of the invention as claimed. Accordingly, the scope of the present invention is defined by the appended claims rather than the foregoing description of one embodiment.

What is claimed is:

1. A method for provisioning a two-way mobile communications device having a display and a user interface, the method being performed by the two-way mobile communications device and comprising:

receiving user information required to establish a user account;

displaying a list of selectable identifiers on the display, each selectable identifier corresponding to a selectable service or feature for which the two-way mobile communications device can be provisioned;

receiving a user's selection of a selectable identifier from the list;

generating a provisioning request comprising the user information and the user's selection;

establishing a communications link with a provisioning server;

providing authentication information to enable a remote server to authenticate the two-way mobile communications device;

sending the provisioning request to the provisioning server over the communications link;

receiving a reply to the provisioning request; and provisioning the two-way mobile communications device with a feature or service based on the reply.

2. The method of claim 1, wherein receiving the reply comprises receiving software to enable the services; and provisioning the two-way mobile communications device comprises installing the software in the two-way mobile communications device.

3. The method of claim 1, wherein receiving the reply comprises receiving activation information to render operational previously installed non-operational software in the two-way mobile communications device.

4. The method of claim 3, wherein provisioning the two-way mobile communications device comprises activating the non-operational software with the activation information.

5. The method of claim 1, wherein establishing the communications link with the provisioning server is accomplished via a wide area communications network.

6. The method of claim 5, wherein the wide area communications network comprises the Internet.

7. The method of claim 6, wherein establishing the communications link is accomplished via a proxy server.

8. The method of claim 7, wherein the proxy server acts as a gateway to bridge communications between an airnet with which the two-way mobile communications device communicates and the wide area communications network with which the provisioning server communicates.

9. The method of claim 8, wherein the remote server, the proxy server, and the provisioning server are included in a single server device.

10. The method of claim 9, wherein the selectable identifiers further correspond to selectable service packages, each package comprising predetermined feature and services configurations for the two-way mobile communications device.

11. The method of claim 10, wherein each selectable identifier comprises an identifier of a corresponding provisioning server.

12. The method of claim 11, wherein the identifier is a uniform resource locator.

13. The method of claim 1, wherein receiving the reply comprises receiving terms and conditions on which a service provider is prepared to provide services.

14. The method of claim 13, further comprising receiving the user's approval of the terms and conditions; and forwarding the user's approval to the provisioning server.

15. The method of claim 1, wherein receiving the reply comprises receiving a notification indicating which services and features have been provisioned.

16. The method of claim 1, wherein receiving the reply comprises receiving a notification relating to a state of processing of the provisioning request.

17. The method of claim 1, wherein establishing the communications link comprises establishing a secure communications link.

18. The method of claim 1, wherein receiving the reply is accomplished on a narrow band channel.

19. The method of claim 18, wherein the narrow band channel is an SMS channel.

20. A provisioning server comprising a processor and a memory coupled thereto, the memory storing instructions which when executed by the processor cause the processor to perform a method comprising:

receiving an authentication request from a proxy server;

sending authentication information to the proxy server in response to the authentication request;

receiving a provisioning request from a two-way mobile communications device as a forwarded message from the proxy server, the provisioning request comprising user information required to establish a user account, device information identifying the two-way mobile communications device, and a user selection indicating a user's selection of services to be provisioned;

verifying the user information and device information; and

provisioning the two-way mobile communications device with the user's selection of services.

21. The provisioning server of claim 20, wherein provisioning the two-way mobile communications device comprises generating notifications relating to terms and conditions associated with a service in the user selection; forwarding the generated notifications to the two-way mobile communications device; and receiving user acceptance of the terms and conditions.

22. The provisioning server of claim 20, wherein provisioning the two-way mobile communications device comprises establishing a communications link with a service server providing a service which has been requested in the provisioning request; and sending a request to the service server requesting registration of the user for the service.

23. The provisioning server of claim 22, wherein the communications link is a secure communication link.

24. The provisioning server of claim 20, wherein provisioning the two-way mobile communications device comprises sending activation information required to activate previously stored non-operational applications in the two-way mobile communications device.

25. The provisioning server of claim 20, wherein provisioning the two-way mobile communications device comprises sending software modules to the two-way mobile communications device to enable the requested services.

26. A method for processing a provisioning request from a two-way mobile communications device, the method comprising:

receiving at a provisioning server, an authentication request from a proxy server;

sending authentication information to the proxy server in response to the authentication request;

receiving the provisioning request from the two-way mobile communications device as a forwarded message from the proxy server, the provisioning request comprising user information required to establish a user account, device information identifying the two-way mobile communications device, and a user selection indicating a user's selection of services to be provisioned;

verifying the user information and device information; and

provisioning the two-way mobile communications device with the user's selection of services.

27. The method of claim 26, wherein provisioning the two-way mobile communications device comprises generating notifications relating to terms and conditions associated with a service in the user selection; forwarding the generated notification to the two-way mobile communications device; and receiving user acceptance of the terms and conditions.

28. The method of claim 26, wherein provisioning the two-way mobile communications device comprises establishing a secure communications link with a service server providing a service which has been requested in the provisioning request; and sending a request to the service server requesting registration of the user for the service.

29. The method of claim 26, wherein provisioning the two-way mobile communications device comprises sending activation information required to activate previously stored non-operational applications in the two-way mobile communications device.

30. The method of claim 26, wherein provisioning the two-way mobile communications device comprises sending software modules to the two-way mobile communications device to enable the requested services.

31. The method of claim 26, wherein the provisioning server is connected to a landnet and the proxy server bridges communications between the landnet and an airnet to which the two-way mobile communications device is connected.

32. The method of claim 26, wherein the user selection further comprises the user's selection of features of the two-way mobile communications device the user wishes activated.

33. A method for provisioning a two-way mobile communications device, the method comprising:

receiving a provisioning request from the two-way mobile communications device;

mutually authenticating the two-way mobile communications device and a provisioning server; and

forwarding the provisioning request to the provisioning server only if the mutual authentication was successful; wherein the receiving, the mutual authenticating, and the forwarding is performed by a proxy server which bridges communications between a first communications network and a second communications network.

34. The method of claim 33, wherein the first communications network is an airnet; and the second communications network is a wide area communications network.

35. The method of claim 34, wherein receiving the provisioning request is via the airnet and forwarding the provisioning request is via the wide area communications network.

36. The method of claim 35, wherein the proxy server exchanges information between the two-way mobile communication device and the provisioning server via mutually exclusive secure communications sessions with the two-way mobile communications device and the provisioning server, respectively.

37. The method of claim 36, wherein the proxy server and the provisioning server are included in a single server device.

38. A proxy server comprising a processor and a memory coupled thereto, the memory storing instructions which when executed by the processor cause the processor to perform a method comprising:

receiving a provisioning request from a two-way mobile communications device;

mutually authenticating the two-way mobile communications device and a provisioning server; and

forwarding the provisioning request to the provisioning server only if the mutual authentication was successful.

39. The proxy server of claim 38, wherein the proxy server bridges communications between a first communications network and a second communications network.

40. The proxy server of claim 39, wherein the first communications network is an airnet; and the second communications network is a wide area communications network.

41. The proxy server of claim 40, wherein receiving the provisioning request is via the airnet; and forwarding the provisioning request is via the wide area communications network.

42. The proxy server of claim 41, which operates to exchange information between the two-way mobile communications device and the provisioning server via mutually exclusive secure communications sessions with the two-way mobile communications device and the provisioning server, respectively.

* * * * *