

NOT FOR PUBLICATION

**UNITED STATES DISTRICT COURT
DISTRICT OF NEW JERSEY**

_____)	
LG ELECTRONICS U.S.A., INC. AND)	
LG ELECTRONICS INC.,)	
)	
Plaintiffs,)	
)	
v.)	Civil Action No. 09-5142 (GEB-ES)
)	
WHIRLPOOL CORP. AND ANCHOR)	
APPLIANCE, INC.,)	MARKMAN OPINION
)	
Defendants.)	
_____)	

BROWN, Chief Judge

This matter comes before the Court on a request from the parties for claim construction in a *Markman* hearing. The parties submitted a Joint Claim Construction Chart (“JCC”) that set forth the parties’ proposed constructions for the forty-seven terms at issue and the intrinsic evidence supporting those constructions; the parties also submitted opening and responsive briefs. (Doc. Ents. 72, 86, 87, 89, 90). After reviewing the parties’ submissions, the Court held a *Markman* hearing on March 18, 2011 and April 1, 2011. The Court construed the majority of the claims at the hearing and this opinion addresses only the remaining terms.

I. BACKGROUND

This is a patent infringement case concerning technologies for French door refrigerators with external ice-dispensers on one of the French doors. Plaintiffs filed this action on October 7, 2009, asserting that Whirlpool infringed one patent, but later amended their complaint to assert

infringement of the other three patents in the action. There four patents at issue are – United States Patent Numbers 7,392,655 (“the ‘665 patent”), 7,484,382 (“the ‘382 patent”), 7,428,820 (“the ‘820 patent”), and 7,490,475 (“the ‘475 patent”). The patented inventions purport to solve problems in the art with the fact that the freezer on these refrigerators is on the bottom, which makes it difficult to dispense the ice traditionally produced there to the doors above. The general solution posed by the patents is to produce ice in a segregated compartment in the refrigerator and dispense the ice to the dispenser on the door.

The ‘655 patent is directed generally to an air duct system with fans and dampers in a French door refrigerator. The patent asserts that the air duct system allows cold air generated in a freezing compartment to be routed to the refrigerating compartment and ice compartment, which is mounted in the top portion of the refrigerator.

The remaining patents, the ‘382, ‘820 and ‘475 patents share a common specification that is generally directed toward an ice and water dispensing system on the French door refrigerator. The claims of the ‘382 patent claim structures for transporting ice from the ice compartments to the dispensers on the door. The ‘820 and ‘475 patents claim differing designs that deliver water to the ice makers and dispensers.

II. DISCUSSION

A. Standard of Review

The first step in a patent infringement analysis is to define the meaning and scope of the claims of the patent. *Markman v. Westview Instruments, Inc.*, 52 F.3d 967, 976 (Fed. Cir. 1995) (*en banc*), *aff'd*, 517 U.S. 370 (1996). Claim construction, which serves this purpose, is a matter of law exclusively for the court. *Id.* at 979. The focus of a court's claim construction analysis must begin and remain on the language of the claims, "for it is that language that the patentee chose to use to 'particularly point[] out and distinctly claim[] the subject matter which the patentee regards as his invention.'" *Interactive Gift Express, Inc. v. Compuserve, Inc.*, 256 F.3d 1323, 1331 (Fed. Cir. 2001) (quoting 35 U.S.C. § 112, ¶ 2).

Generally, there is a presumption that the words of a claim will receive the full breadth of their ordinary meaning. *NTP, Inc. v. Research In Motion, Ltd.*, 392 F.3d 1336, 1346 (Fed. Cir. 2004). The ordinary meaning may be derived from a variety of sources; including intrinsic evidence, such as the claim language, the written description, drawings, and the prosecution history; as well as extrinsic evidence, such as dictionaries, treatises, or expert testimony. *Id.*

When determining the meaning of the terms, the court must primarily consider the intrinsic evidence, including the specification and prosecution history. *Vitronics Corp. v. Conceptoronic, Inc.*, 90 F.3d 1576, 1582-83 (Fed. Cir. 1996). The specification "is the single best guide to the meaning of a disputed term." *Id.* at 1587. However, it is improper to import limitations from the specification into the claims. *Phillips v. AWH Corp.*, 415 F.3d 1303, 1320, 1323 (Fed. Cir. 2005); *Resonate Inc. v. Alteon Websystems, Inc.*, 338 F.3d 1360, 1364-65 (Fed. Cir. 2003). Courts "should also consider the prosecution history of the asserted patents" because

it “can inform the meaning of the claim language by demonstrating how the inventor understood the invention and whether the inventor limited the invention in the course of prosecution.”

Telcordia Techs., Inc. v. Cisco Sys., 612 F.3d 1365, 1372 (Fed. Cir. 2010); *Phillips*, 415 F.3d at 1317. Courts should, however, grant the communications in the prosecution history less weight than the specification because they are negotiations and “often lack[] the clarity of the specification.” *Phillips*, 415 F.3d at 1317.

In addition to the specification and prosecution history, a court may also consider extrinsic evidence to determine the meaning of a term when an analysis of the intrinsic evidence alone does not resolve the ambiguities of a disputed claim term. *Vitronics Corp.*, 90 F.3d at 1582-83. However, such evidence should be accorded less weight than the intrinsic record and should never be used to contradict the intrinsic evidence. *Phillips*, 415 F.3d at 1324.

B. Analysis

The terms that remain to be construed are:

- (1) proximate to;
- (2) a damper configured to regulate air flow, from the ice compartment to the refrigerating compartment, through an opening in the wall of the ice compartment
- (3) damper is configured to enable regulation of a temperature associated with the refrigerating compartment, through the opening in the wall of the ice compartment;
- (4) ice transportation mechanism located within the ice compartment configured to promote the movement of ice stored within the ice compartment through an outlet defined in the ice compartment;
- (5) ice transportation mechanism is configured to, when the first door is in the closed position and the ice discharge duct is opened, transport ice stored within the ice compartment to the dispenser through the first and second portions of the ice discharge duct;
- (6) wherein the ice discharge duct is selectively opened and closed such that ice can be transferred to the dispenser positioned on the first door;

- (7) the ice discharge duct is selectively opened and closed independent of the movement of the first door;
- (8) dispenser tube configured to guide liquid water to the dispenser; and
- (9) dispenser tube being different than the ice maker tube.

These terms appear in a variety of claims in the four patents. The Court provides its constructions and the reasons for those constructions below.

1. proximate to

'665 patent, claims 10 and 32; '475 patent, claims 1, 2, 6, 7, 11, 12

LG's Construction	Whirlpool's Construction
in or very near	very near

(JCC at 8).

Both parties agree that the plain meaning of “proximate” means “very near” and does not include being “in.” (LG’s Op. Br. at 17). Further, neither party alleges that people in the art understand the term to mean anything other than “very near.” However, LG argues that the patent uses the term in a broader sense so as to redefine the term by implication. (*Id.* at 18). LG points to two inferences that can be drawn from the claims that suggest that “proximate” includes being inside something. The Court finds that these inferences are insufficient demonstrate a clear intent to redefine the term as required by the caselaw.

There is a presumption that the claim term be given the full breadth of its ordinary meaning. *NTP, Inc. v. Research In Motion, Ltd.*, 392 F.3d 1336, 1346 (Fed. Cir. 2004). While a patentee may redefine the plain meaning of a term, such intent must be clear. *Merck & Co, Inc. v. Teva Pharms. USA, Inc.*, 395 F.3d 1364, 1370 (Fed. Cir. 2005). The Federal Circuit has “repeatedly encouraged claim drafters who choose to act as their own lexicographers to clearly define terms used in the claims in the specification.” *Sinorgchem Co. v. ITC*, 511 F.3d 1132,

1136 (Fed. Cir. 2007). However, where the intent is clear, a redefinition may be accomplished by implication.

There is no dispute that the patentee did not act as his own lexicographer in the specification or, by repeated and consistent use, redefine the terms. However, Plaintiffs argue that several inferences lead to the conclusion that “proximate” includes being “in.”

First, Plaintiffs argue that claim 10 of the ‘665 patent requires this construction. Claim 10 of the ‘665 patent claims “an evaporator positioned in the refrigerator body *proximate* to the freezing compartment,” (‘665 patent, 14:22-28) (emphasis added), but claim 11, which depends from claim 10, states that the “evaporator is positioned *in* the freezing compartment[.]” (‘665 patent, 14:27-31) (emphasis added). Because claim 10 must be broader than its dependent claim 11, this suggests that “proximate” includes being “in.”

The Court does not find this persuasive. The Court will not allow improper dependency or poor drafting to inure to the benefit of the drafter, who was required to put the public on notice of his invention. *Haemonetics Corp. v. Baxter Healthcare Corp.*, 607 F.3d 776, 781 (Fed. Cir. 2010) (purpose of claims is to notice the public of the scope of the invention). The patentee had every reason to be careful with the wording he used in this ex-parte proceeding. He should not be able to take advantage of such errors to suggest a “clear” redefinition of a term.

Further, while the specification does state in preferred embodiments that “the freezing chamber **51** is provided with an evaporator **65**” and speaks of a “first duct **70** for supplying the cold air formed around the evaporator **65** *in the freezing chamber 51*,” (‘665 patent, 8:41-42; 931-34) (emphasis added), these are also less than clear. Given that the Figures these descriptions purport to be describing show the evaporator partitioned from the portion labeled as

the freezing chamber, these statements seem to refer only to the general location of the evaporator. ('665 patent, Fig. 6-9).¹

Second, Plaintiffs argue that excluding “in” from the definition of “proximate” would read a preferred embodiment out of the claims in the ‘475 patent. Plaintiffs argue that all of the relevant claims of the ‘475 patent list the “branch point,” which is where the water line splits into a line supplying the ice-maker and a line supplying the water dispenser, as being “proximate to” a wall of the refrigerator. ('475 patent, 11:65-12:3; 12:8-13). However, the specification lists tubes for the water line, **54**, **55**, and **58** as “preferably *embedded* into a rear side of an inner case or an insulating material of the walls of the refrigerating chamber **3** so that they are not exposed to the interior of the refrigerating chamber **3**.” ('475 patent at 8:29-34). This text describes

Figure 6:

¹ The Court notes that LG does not argue that such a construction reads a preferred embodiment out of the claims. (LG Op. Br. at 17-18; LG Resp. Br. at 5-7). However, even so, the Court finds that this language refers only to the general position of the evaporator in the bottom of the refrigerating unit.

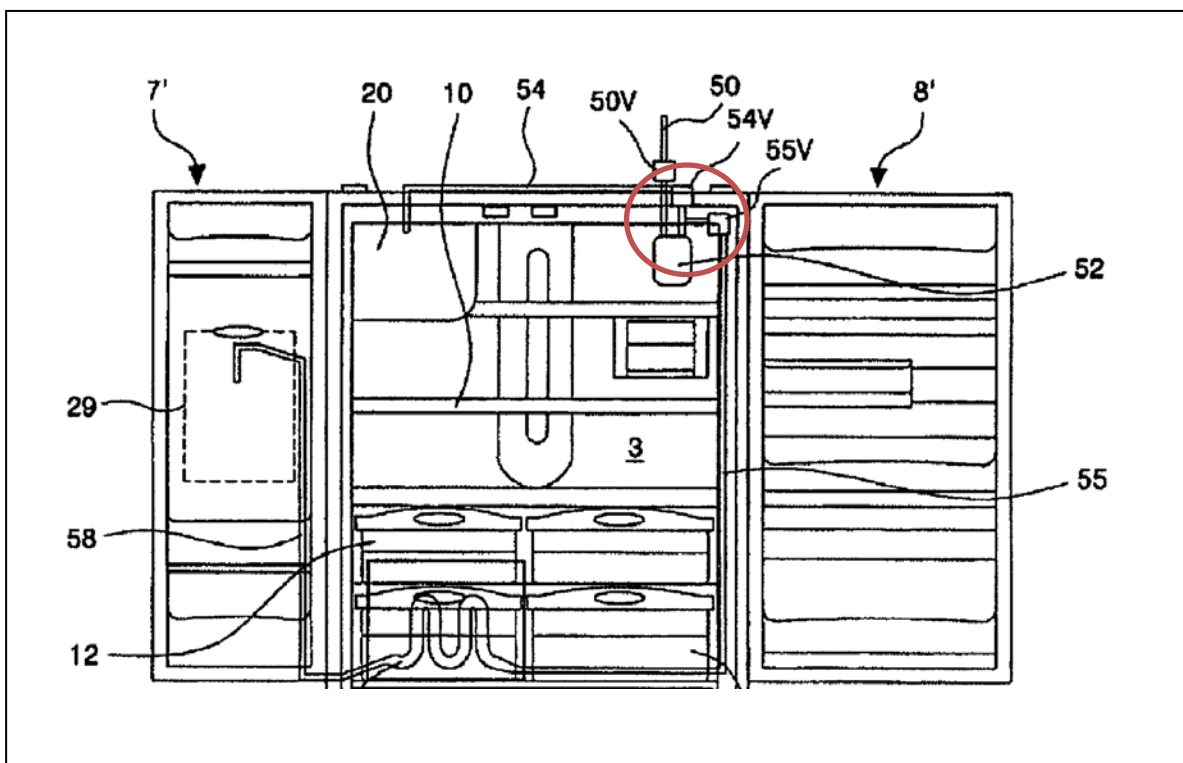

(‘475 patent, Fig. 6) (red circle added). Labels **54**, **55** and **58** are the tubes described and **54V** and **55V** are valves. (‘475 patent, 8:13-15). In the circled area, there appears to be a branch point within the wall of the refrigerator. Plaintiffs argue that this requires “proximate” to include “in” or this preferred embodiment would be excluded from the claim and a claim construction that excludes preferred embodiments “is rarely, if ever, correct and would require highly persuasive evidentiary support.” *Vitronics*, 90 F.3d at 1583.

However, it is less than clear that the picture depicts a branch point. As argued by Defendants, the description of Figure 6 does not require that there even be a branch point in the preferred embodiment. Earlier in the description of Figure 6, where the filter and the tubes are described, the description does not use a branch point, but lists it as optional, not preferred:

The water purified in the filter **52** is transferred to the icemaker **24** and a water tank **56** through an icemaker tube **54** and a tank tube **55** respectively. . . . Of

course, the water *may be* supplied in such a manner that a single tube stems from the filter **52** and the icemaker tube **54** and the tank tube **55** are branched off *through a single valve*.

(‘475 patent, 8:10-18) (emphasis added). Further, if this configuration depicts the branch point, it certainly does not depict them as branched through a single valve, as the valves **54V** and **55V** are depicted as small boxes, not as a possible split in the line.

Even if the picture happens to depict a branch point, it is not a necessary part of the preferred embodiment. The passage mentioning that the tubes are preferably embedded in the walls does not mention a branch-point and the language quoted above suggests that it is optional. As such, part of the preferred embodiment is tubes without a branch point. This portion of the preferred embodiment could be depicted.

However, it cannot be disputed that only embodiments with branch-points are claimed in the ‘475 patent and, therefore, separate tubes coming from the filter are not. This might lead to the entirety of this preferred embodiment (‘475 patent, 5:37-40) being read out of the claims. The logic of this argument is this: If it is undisputed that branch points are the only sub-embodiments claimed, then the embedded tubes of this preferred embodiment described in the discussion of Figure 6 must include a branch point somewhere, otherwise the construction reads a preferred embodiment out of the claims.

The Court’s construction would not necessarily read this embodiment out of the claims. A sub-embodiment could be part of the claims. For example, a refrigerator with a branch point valve abutting the top of the refrigerator, with the tubes exiting the valve and entering the wall of the refrigerator, would fall within the claims and would reflect the preferred embodiment.²

² Any argument that every sub-embodiment of a preferred embodiment must be present in the claims must fail on this specification. There is no question that the specification discloses a sub-embodiment without a branch point. However, only branch points are claimed.

As such, the construction does not necessarily read a preferred embodiment out of the claims. The Court further notes that even if this construction read a preferred embodiment out of the claims, the presumption from *Vitronics* is mitigated here. The fact that the ‘475 patent does not claim the preferred embodiment does not necessarily mean that the patentee did not claim the preferred embodiment in *any* of his patents. Indeed, the ‘820 patent, which has the same specification, claims embodiments that do not require a branch point.

With this issue avoided, there is no reason to redefine the term. Both parties agree that the plain meaning of the term “proximate” means “very near.” Further, it cannot be disputed that the patentee did nothing to clearly define the term – implications buried in claim dependency and inclusion of what might, or might not, be preferred embodiments simply do not qualify. *Merck*, 395 F.3d at 1370 (redefinition must be clear); *Helmsderfer v. Bobrick Washroom Equipt., Inc.*, 527 F.3d 1379, 1381 (Fed. Cir. 2008). “Patent claims function to delineate the precise scope of a claimed invention and to give notice to the public, including potential competitors, of the patentee’s right to exclude.” *Haemonetics Corp.*, 607 F.3d at 781; *see also Markman v. Westview Instruments, Inc.*, 517 U.S. 370, 373 (1996). This purpose would be substantially undermined if patentees could rely upon buried implications to redefine claim terms.

2. ***a damper configured to regulate air flow, from the ice compartment to the refrigerating compartment, through an opening in a wall of the ice compartment***
 ‘665 patent, claim 21

LG’s Construction	Whirlpool’s Construction
No construction necessary. Alternatively, “a damper that regulates the flow of air from the ice compartment to the refrigerating compartment through an opening in the wall of the ice compartment”	Indefinite. Alternatively, “a damper that regulates the flow of air that has first entered the interior of the ice compartment as it flows to the refrigerating compartment through an

	opening in a wall of the ice compartment”
--	---

(JCC at 12).

3. ***damper is configured to enable regulation of a temperature associated with the refrigerating compartment, through the opening in the wall of the ice compartment***
‘665 patent, claim 23

LG’s Construction	Whirlpool’s Construction
No construction necessary. Alternatively, “a damper that regulates the refrigerating compartment temperature by regulating the flow of air from the ice compartment to the refrigerating compartment through the opening of the ice compartment”	Indefinite. Alternatively, “a damper that regulates the refrigerating compartment temperature by regulating the flow of air that has first entered the interior of the ice compartment as it flows to the refrigerating compartment through an opening in a wall of the ice compartment.”

(JCC at 13-14).

Stripped of the indefiniteness question,³ the dispute between the constructions is whether the flow of air must first enter the interior of the ice compartment before flowing to the refrigerating compartment. Despite some illumination at oral argument, the Court is still somewhat baffled by the significance of the difference in explicitly including this limitation. If the damper regulates air flowing through a hole from the ice compartment to the refrigerating

³ The Court defers an indefiniteness determination because its dispositive effect and high burden of proof make it more appropriate for summary judgment. There is a high burden of proof on a party challenging the patent based on indefiniteness, which would be difficult to meet at this early stage. Indefiniteness is proven only “where an accused infringer shows by *clear and convincing* evidence that a skilled artisan could not discern the boundaries of the claim.” *Halliburton Energy Servs., Inc., v. M-I LLC*, 514 F.3d 1244, 1249-50 (Fed. Cir. 2008) (emphasis added). Further, rather than giving meaning to a claim, as a *Markman* hearing is meant to do, indefiniteness invalidates the patent claims entirely. *Exxon Research & Eng'g Co. v. United States*, 265 F.3d 1371, 1376 (Fed. Cir. 2001). This dispositive effect is more appropriately tackled at summary judgment. Thus, this Court finds persuasive the determinations of several other courts to defer indefiniteness until summary judgment. *See, e.g., Intergraph Hardware Techs. Co. v. Toshiba Corp.*, 508 F. Supp. 2d 752, 773 n.3 (N.D. Cal. 2007) (“[The] indefiniteness argument is inappropriate at the claim construction stage.”); *Pharmastem Therapeutics, Inc. v. Viacell Inc.*, 2003 U.S. Dist. LEXIS 877, at *2 n.1 (D. Del. Jan. 13, 2003) (“[T]he court will not address the defendants’ indefiniteness argument at [the *Markman* stage].”). Indeed, the Federal Circuit in *Halliburton*, *Exxon*, and *Datamize* reviewed courts that dismissed the case for indefiniteness at summary judgment, not at a prior *Markman* hearing. *Halliburton*, 514 F.3d at 1249; *Exxon*, 265 F.3d at 1373; *Datamize, LLC v. Plumtree Software, Inc.*, 417 F.3d 1342, 1347 (Fed. Cir. 2005).

compartment, that seems to necessarily imply that the air originated in the interior of the ice compartment. Thus, the plain meaning of the term seems to amply impart this restriction.⁴ In sum, the Court does not see the practical difference between the two constructions.

However, because the parties continue to dispute the distinction, the Court will consider it. The merits of the limitation involve an analysis of the recent prosecution history reexamining the patent at issue. Whirlpool alleges that the LG disclaimed any other arrangement in distinguishing the Tenmyo reference. However, because the plain meaning of the term effectively differentiated the prior art, the Court finds that the patentee's conduct in reexamination does not amount to an unequivocal disavowal of a claim scope. *Vizio, Inc. v. Int'l Trade Comm'n*, 605 F.3d 1330, 1339 n.6 (Fed. Cir. 2010) (disclaimer must be a clear and unequivocal disavowal of claim scope); *Linear Tech. v. Int'l Trade Comm'n*, 566 F.3d 1049, 1057-59 (Fed. Cir. 2009) (same).

The prosecution history that Whirlpool relies upon is this. Faced with a rejection based on Tenmyo, the patentee, in addition to alleging it predated Tenmyo, also distinguished it as follows:

Below, claims 21-36 and 38-41 are addressed based on features recited by claims 21 and 41. Specifically, independent claim 21 recites, among other things, a damper configured to regulate air flow, from an ice compartment to a refrigerating compartment, through an opening in a wall of the ice compartment. Tenmyo, while disclosing a damper, contrasts with this aspect of the claim since the Tenmyo damper regulates air flow from a source other than an ice compartment.

(Nov. 29 reply to Sept. 29, 2010 Action; Durnham Cert. Ex. S; D.E. 86-5) (emphasis in original).⁵ As such, the patentee used the very language of the claim, that the air came “from an

⁴ On the other hand, if the limitation is implicitly in the plain meaning, no harm can accrue from including it.

⁵ The patentee's amended response of March 22, 2011, is identical to the November 29, 2010 reply in all material respects. In fact, other than some attempts to shorten the response, the language is a copy-paste of the prior response.

ice compartment,” to distinguish the prior art. When the patentee uses the unqualified language of the claims to distinguish the prior art, that cannot be said to disclaim any of the scope of the claims.

When the patentee elaborates, he points to the figure from Tenmyo reproduced below:

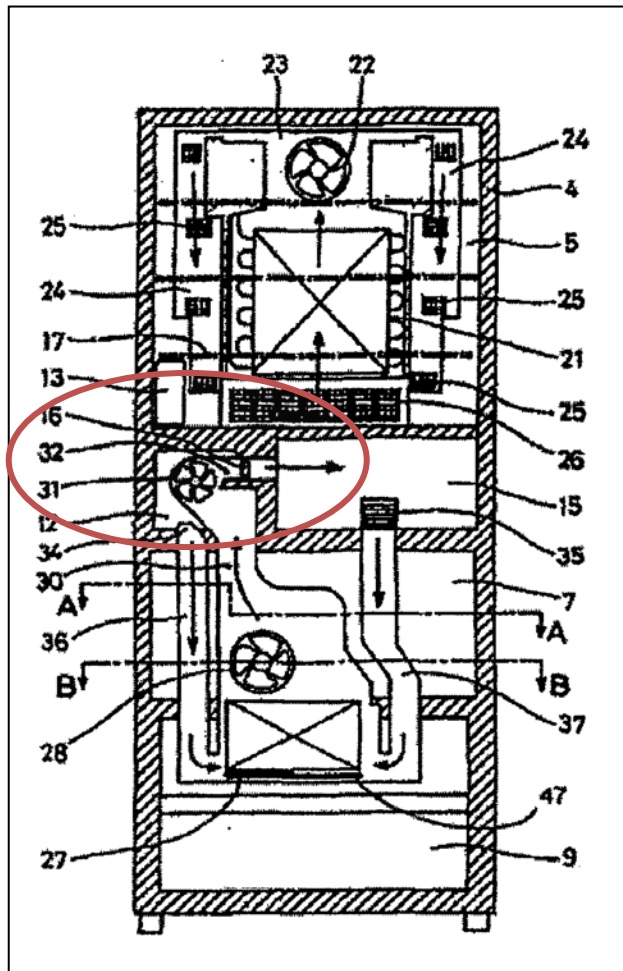

(Red circle added). The patentee explains that the fan 31, sends some air directed out of the page to the icemaker compartment, and some to the right to the damper 16. (*Id.* at 41). As such, the patentee argued that the fan splits the air and the air coming to the damper does not come from the ice compartment at all, but is a separate stream from the one that flows from the fan to the ice compartment.⁶ (*Id.*).

⁶ The Court notes that the patentee’s conclusion that the fan is not in or part of the ice compartment is somewhat dubious given that the description of Tenmyo states that the fan 31 is “provided in the back of the icemaker

While Whirlpool is correct that the patentee states that the air passing to the damper 16 “is not passed through Tenmyo’s ice-maker compartment 12[,]” (*id.* at 42), the Court concludes that the language of the claims itself effectively distinguishes Tenmyo as conceptualized by the patentee.

While the language Whirlpool proposes to add seems innocuous because its meaning is imparted by the claim language itself, the Court declines to add this additional language to the claim. At this stage of the proceeding the Court has little knowledge of the allegedly infringing refrigerator and, as such, does not know what creative meanings the parties will assign to this additional language. If LG is attempting to apply its claims to an arrangement that does not pass the air from the icemaker, Whirlpool may prevail on noninfringement at summary judgment.⁷ However, the plain language of the claims is enough to allow Whirlpool to assert this defense.⁸ Consequently, the Court finds that no construction of either term is necessary.

4. *ice transportation mechanism located within the ice compartment configured to promote movement of ice stored within the ice compartment through an outlet defined in the ice compartment.*
 ‘382 patent, claim 1

LG’s Construction	Whirlpool’s Construction
a mechanism that is separate from the ice maker and is capable of moving ice stored in the ice compartment through an outlet of the ice compartment (e.g., screw wires capable of moving ice by means of their rotation.)	Indefinite as § 112 ¶ 6 with no corresponding structure. Alternatively, construed under § 112 ¶ 6 to mean “rotating screw wires horizontally-disposed in an ice storage area of the ice compartment”

compartment (12)” and that the fan is named the “ice-maker fan.” However, for the purposes of disclaimer, the patentee’s distinction of the prior art must be taken at his word. Whether the patentee was incorrect, and the fan is in the ice-maker compartment (thus making the air flow from the ice-maker compartment, not a portion separate from the compartment), is an inquiry relevant to anticipation and obviousness, not of claim construction.

⁷ Further, to the extent that Whirlpool merely practices the arrangement set forth in Tenmyo, it may have a strong invalidity defenses.

⁸ The Court also declines to construe this term under § 112 ¶ 6, because the word “damper” provides a well-known structure and that structure is narrowed by the functional language. *See MIT*, 462 F.3d 1344, 1355-56 (finding that “aesthetic correction circuit” was not a means-plus function term because “circuit” provided structure, and its purpose further defined that structure).

--	--

(JCC at 19).

5. ***ice transportation mechanism is configured to, when the first door is in the closed position and the ice discharge duct is opened, transport ice stored within the ice compartment to the dispenser through the first and second portions of the ice discharge duct.***

‘382 patent, claim 9

LG’s Construction	Whirlpool’s Construction
No construction necessary. Alternatively, “the ice transporting mechanism moves ice from the ice compartment to the dispenser through the ice discharge duct when the first door is closed and the ice discharge duct is open.”	Indefinite as § 112 ¶ 6 with no corresponding structure. Alternatively, construed under § 112 ¶ 6 to mean “rotating screw wires horizontally-disposed in an ice storage area of the ice compartment”

(JCC at 23).

The difference between the two constructions is that Whirlpool suggests that the term should be construed as a means-plus-function term, despite the fact that it does not include the words “means for.” Whirlpool proposes that this is appropriate because the claim term is purely functional and there is no class of structures in the art known as an ice transportation mechanism. (Whirl. Op. Br. at 9-10). Whirlpool also points out that the Federal Circuit has held repeatedly that “mechanism” recites no structure at all and asserts that “ice transportation” adds no structure to the term. (Whirl. Resp. Br. at 13 (citing *Welker Bearing Co. v. PhD, Inc.*, 550 F.3d 1090, 1096-97 (Fed. Cir. 2008)). Thus, Whirlpool concludes that the term should be construed as a means-plus-function term and, as such, limited to the structure set forth in the specification – horizontal screw wires. *See* 35 U.S.C. § 112 ¶ 6 (means-plus-function construed as structure in the specification and equivalents); *Lighting World, Inc. v. Birchwood Lighting, Inc.*, 382 F.3d 1354, 1358 (Fed. Cir. 2004) (same).

LG argues that this term would be understood by a person in the art as denoting a specific range of structures because it describes the structural relationship between the ice transporting mechanism, the ice compartment, and the outlet defined in the ice compartment. (LG Op. Br. at 14). The Court agrees with Whirlpool and construes the term as a means-plus-function term.

Where the words “means for” do not appear in the claim term, there is a strong presumption that the claim term should not be construed as a means-plus-function term. *Massachusetts Institute of Technology and Electronics For Imaging, Inc. v. Abacus Software (MIT)*, 462 F.3d 1344, 1355-56 (Fed. Cir. 2006). The Federal Circuit has stated that “we have seldom held that a limitation not using the term ‘means’ must be considered to be in means-plus-function form” and that “the circumstances must be [unusual] to overcome the presumption.” *Id.* (alterations in original). To avoid being construed as means-plus-function, the term need not “denote a specific structure” but may avoid such construction “even if the term identifies the structures by their function.” *Id.* Indeed, many common “devices take their names from the functions they perform” including devices such as screwdrivers and clamps. *Greenberg v. Ethicon Endo-Surgery, Inc.*, 91 F.3d 1580, 1582 (Fed. Cir. 1996).

However, the presumption that a term without “means for” should not be construed as a means-plus-function term can be rebutted “by showing that the claim element recite[s] a function without reciting sufficient structure for performing that function” and does not enable one of ordinary skill to identify a class of appropriate structures. *DePuy Spine, Inv. v. Medtronic Sofamor Danek, Inc.*, 469 F.3d 1005 (Fed. Cir. 2006); *see also MIT*, 462 F.3d at 1356; *CCS Fitness, Inc. v. Brunswick Corp.*, 288 F.3d 1359, 1369 (Fed. Cir. 2002).

Whirlpool is correct that the word “mechanism” is a “nonce” word that does not provide any structure to a claim limitation. *Welker Bearing Co. v. PhD, Inc.*, 550 F.3d 1090, 1096-97

(Fed. Cir. 2008); *MIT*, 462 F.3d at 1354. Essentially, “mechanism” sounds like structure but does not tell the person of skill in the art anything other than the item is intended to accomplish a function, which is exactly what the term “means” would accomplish in its place. *See MIT*, 462 F.3d at 1354. However, the fact that the patentee used the word “mechanism” does not end the inquiry.

Where the term at issue uses substantial functional language or a “nonce” words such as the term “mechanism,” the surrounding language and its usage in the art is an important consideration in determining whether the presumption has been overcome. *See DePuy Spine, Inc. v. Medtronic Sofamor Danek, Inc.*, 469 F.3d 1005, 1023 (Fed. Cir. 2006) (finding that claim limitations requiring a “compression member” to fit into a cylindrical opening and to exert force on a screw head weighed against means-plus-function construction). For example, in *MIT*, the Federal Circuit confronted two terms – “colorant selection mechanism” and “aesthetic correction circuitry.” The court found that “colorant selection mechanism” was a mean-plus-function term because “mechanism” did not provide structure and the language modifying it “colorant selection” merely provided a purpose but no structure. 462 F.3d 1344, 1355-56 The court based this conclusion on the fact that no dictionary definition denoted that the term was used as a name for a structure in the art and that the record was devoid of “any suggestion that it had a generally understood” meaning in the art as a structure. *Id.* However, the court found that “aesthetic correction circuitry” denoted sufficient structure because, the word “circuit” denoted structure and the words “aesthetic correction” provided additional information on the type of circuit that was contemplated. *Id.* at 1355. Thus, where structure appears in the term, functional language modifying it can prevent § 112 ¶ 6 treatment; however, where a “nonce” word appears, words designating purpose that do not themselves designate a structure do not save the limitation.

However, where the words surrounding “mechanism” themselves constitute a well known set of structures in the art, the claim should not be construed as means-plus-function. In *Greenberg v. Ethicon Endo-Surgery, Inc.*, the Federal Circuit found that “detent mechanism” was not a means-plus-function claim because the word “detent” itself was a noun that was well known as a structure both in the art and in dictionaries. 91 F.3d 1580, 1582-84 (Fed. Cir. 1996). The fact that the dictionaries defined “detent” in terms of its function was irrelevant because, despite its functional meaning, it denoted a well-known structure in the art. *Id.* at 1583; *see also Cole v. Kimberly-Clark Corp.*, 102 F.3d 524, 530-532 (Fed. Cir. 1996) (“perforation means” denoted structure because perforation itself is a well-known structure and the word “means” was not intended to invoke means-plus-function claiming); *Lighting World, Inc. v. Birchwood Lighting, Inc.*, 382 F.3d 1354, 1358 (Fed. Cir. 2004) (“connector assembly” not means-plus-function because “connector” has a well understood structure, as evidenced by numerous dictionary definitions). Similarly, in *DePuy Spine, Inc. v. Medtronic Sofamor Danek, Inc.*, the court found that because “compression member” had several dictionary definitions that supported that it was a well known structure and because both experts agreed that it denoted a kind of structure in the art, the term was not a means-plus-function limitation. 469 F.3d 1005, 1023 (Fed. Cir. 2006).

There is nothing in the claim here that provides structure to one of skill in the art. In this case, the term “ice transportation mechanism” uses a “nonce” term and the surrounding language does very little to provide structure. Like “colorant selection mechanism” in *MIT*, there is no suggestion in the record, based on a dictionary definition or the experts, that this term has denotes a well known set of structures in the art. While it would not matter if the set of structures was broad, so long as one of skill would know that it designated certain structure,

Lighting World, 382 F.3d at 1359-60, here there is no suggestion before the Court that the purpose designates any understood structure at all. Further, “ice transportation” does not add structure to the nonce word “mechanism.” In sum, there is no structure in either “mechanism” or “ice transportation mechanism” that the purpose could add specificity to. *See MIT*, 462 F.3d at 1355-56 (construing “colorant selection mechanism” as a means-plus function claim, but construing “aesthetic correction circuitry” in line with its plain meaning because “circuit” provided a base of structure upon which “aesthetic selection” elaborated). Finally, the words surrounding the claim do not add to the information about the term – they only give the origin and destination of the ice transported, without clues about the structure that transports the ice there.

Thus, the Court concludes that the term is a means-plus-function term and construes it as limited to those structures disclosed in the specification. However, LG is correct that Whirlpool’s proposed construction reads a limitation into the claims that is not even required by the specification – that the screw wires be *horizontal*. Indeed, while the Figure shows that the wires are horizontal, the specification does not so require:

The ice storage 26 temporarily stores the ice delivered from the icemaker 24, and the ice stored in the ice storage 26 is transported by a mechanism for delivering the ice (e.g. screw wires capable of moving the ice by means of their rotation.)

(‘382 patent, 6:28-33). As such, the Court construes “ice transportation mechanism” as “screw wires capable of moving ice by means of their rotation and equivalent structures.”

6. *wherein the ice discharge duct is selectively opened and closed such that ice can be transferred to the dispenser positioned on the first door*
 Claims 1, 18 of the '382 patent

LG's Construction	Whirlpool's Construction
No construction necessary. Alternatively, "the ice discharge duct is opened and closed in response to a selection to allow ice to be moved from the ice compartment to the dispenser."	Indefinite as a § 112 ¶ 6 term without corresponding structure.

(JCC at 21).

7. *the ice discharge duct is selectively opened and closed independent of the movement of the first door*
 Claims 4, 19 of the '382 patent

LG's Construction	Whirlpool's Construction
No construction necessary. Alternatively, "the opening and closing of the ice discharge duct does not require movement of the door."	Indefinite. Indefinite as a § 112 ¶ 6 term without corresponding structure

(JCC at 21).

At the *Markman* hearing Whirlpool acquiesced to deferring an indefiniteness determination until dispositive motions; however, Whirlpool proposed that the Court read the term in light of what it asserts is a prosecution history disclaimer that the closed duct must be airtight. The Court concludes that the prosecution history is not sufficiently clear to constitute a disclaimer. *See Linear Tech*, 566 F.3d at 1057-59 (prosecution history must provide a clear disavowal of claim scope to limit the plain meaning of the claims).

Claim 4, which incorporates independent claim 1, contains both these limitations and is representative of claims 18, and 19 (which depend from claim 14). The terms at issue appear during the discussion of the ice discharge duct after the claim sets forth the location of the

freezer on the bottom, the refrigerator at the top, the ice compartment within the refrigerator, and the two French doors on the refrigerator. The patent goes on to claim:

a dispenser positioned on the first door corresponding to the ice compartment;

an ice discharge duct that, when the first door corresponding to the ice compartment is in the closed position, extends at least partially between the ice compartment and the dispenser and defines a passage to discharge ice transported from the ice compartment, the ice discharge duct including:

a first portion being defined as a cavity that penetrates the first door, and

a second portion that is configured to be separated from the first portion when the first door is in an opened position and being configured to interface with the first portion when the first door is in a closed position;

wherein the ice discharge duct is selectively opened and closed such that the ice can be transferred to the dispenser positioned on the first door;

wherein the ice discharge duct is selectively opened and closed independent of the movement of the first door.

(‘382 patent, 11:45-12:25) (emphasis added). Essentially, this maps forth an ice discharge duct that is split into two portions; one part stays on the door when it opens, the other part remains on the body of the refrigerator, but when the door is closed, they line up and create a united duct where ice can pass from one to the other and then into the dispenser.

In the reexamination of the patent, the patentee does not, as Whirlpool suggests, distinguish Fisher based upon the fact that Fisher’s duct is not air-tight. Rather, in context, LG argues that there is a *third* chute in the Fisher reference that is opened and closed, and as a result, neither portion of Fisher’s ice discharge duct is opened or closed – it is the third chute above that is opened and closed. (Jan. 31, 2011 Reply to Nov. 30, 2010 Action at 23-24; Durnham Cert. Ex. X; D.E. 86-6). The patentee made the statement about “air (or other content)” to demonstrate that both ducts remained open even when the flapper was closed and it was only the

third duct that Fisher's flapper closed, not to suggest that Fisher differed from the patent only in its lack of an air-tight flapper. (*Id.* at 25).

Specifically, the patentee distinguished Fisher as follows:

Independent claim 1 recites, among other things, an ice discharge duct that includes a first portion being defined as a cavity that penetrates the first door and a second portion that is configured to be separated from the first portion when the door is in an opened position and being configured to interface with the first portion when the first door is in a closed position, where the ice discharge duct is selectively opened and closed such that ice can be transferred to the dispenser positioned on the first door. . . .

[T]he Reexamination Request contends that Fisher's flapper door **114** selectively opens and closes Fisher's ice discharge duct, as required by claim 1. Patentee disagrees.

Fisher's flapper door **114** does not open and close the aspects of Fisher that are mapped (by the Request itself) to the claimed ice discharge duct, as Fisher's flapper door **114** fails to open or close either of Fisher's separate chute 112 (mapped by the Request to the second portion of the claimed discharge duct) or Fisher's inner door chute **128** (mapped by the Request to the first portion of the claimed discharge duct). Rather, the only chute that is opened and closed by Fisher's flapper door **114** is chute **72**, which does not correspond to opening or closing of either of the chutes (112, 128) that are mapped by the Reexamination Request to the claimed ice discharge duct.

(*Id.* at 23-24) (citations omitted, emphasis added). This statement distinguishes Fisher not based upon Fisher's lack of an air-tight closure, but based upon the fact that its flapper closes a third chute that is not present in the claimed invention. As such, there is no clear disavowal of claim scope that the closure must be air-tight.

Whirlpool also argues that LG clearly distinguished the prior art by pointing out that the prior art's opening and closing member controlled the flow of ice "out of the dispenser" and not "to the dispenser" as exists in the patent. (Whirl. Op. Br. at 26). While LG did so distinguish, it did not limit the scope of the claims. Again, the claim terms themselves contain this limitation.

The claim term states:

wherein the ice discharge duct is selectively opened and closed such that the ice can be transferred to the dispenser positioned on the first door.

(‘382 patent, 12:10-15) (emphasis added). Thus, the claim term itself contains this language, and it properly distinguishes the scope of the claims from the prior art. Any additional limitation is superfluous and would be unwise to adopt at this stage of the litigation.

Consequently, the Court finds that the patentee committed no clear disavowal of claim scope and construes the term in line with its plain meaning. *See Linear Tech*, 566 F.3d at 1057-59 (prosecution history must provide a clear disavowal of claim scope to limit the plain meaning of the claims).

8. *a dispenser tube configured to guide liquid water to the dispenser*⁹
 ‘820 patent, claims 1, 11, 13

LG’s Construction	Whirlpool’s Construction
No construction Alternatively, “a dispenser tube that guides liquid water to the dispenser”	a tube that extends from the outlet of a water tank to an inlet of a dispenser

(JCC at 27).

9. *dispenser tube being different than the ice maker tube*
 ‘820 patent, claims 1, 11, 13

LG’s Construction	Whirlpool’s Construction
No construction Alternatively, “the dispenser tube is different than the ice maker tube”	the tube that extends from the outlet of a water tank to an inlet of a dispenser is separate from the tube that extends from a water source to the inlet of the icemaker

(JCC at 27).

⁹ Whirlpool abandoned its indefiniteness arguments for these terms.

The major differences between these constructions are (1) that Whirlpool's constructions require that the dispenser tube extend from a "water tank" and (2) that Whirlpool's constructions use the term "separate" instead of "different," which is present in the claims.

Whirlpool seems to be concerned that LG will argue at trial that the tubes different in color or path, and so wants to limit it to separate tubes, and suggests that the only "different" tubes supported by the specification are those that do not branch. The specification describes branching tubes as "stem[ing]" from one another. ('820 patent, 8:14-17). Whirlpool further argues that the dispenser tube must extend from the water tank to the dispenser because the Summary and preferred embodiments consistently describe the "dispenser tube" as "delivering water from the water tank to the dispenser." (Whirl. Op. Br. at 29) (citing '820 patent, 8:58-60, Fig. 7; '820 patent, 4:60-61, 8:20-22). Whirlpool also points to the prosecution history where, in an amendment, the applicant cancelled all claims relating to the "branched" configuration and filed these in a divisional that became the '475 patent. (Whirl. Op. at 28).

Despite Whirlpool's arguments, the Court concludes that the term does not require construction because: (1) the prosecution history is not sufficiently clear to limit the claim term and (2) the specification's limitations on the dispenser tube describe only a preferred embodiment and not the invention as a whole.

The Court is not persuaded by Whirlpool's prosecution history argument. Whirlpool reads too much into this conduct without explicit evidence of motive. LG could have deleted the "branched" configuration and filed it in a separate patent because LG wanted a genus patent and a species patent. This is supported by the fact that the preferred embodiments depict branching. ('820 patent, Fig. 6, 8:14-17). While Whirlpool's interpretation of the prosecution history may be correct, it falls far short of the clarity required to change the meaning. This is exactly the kind

of unclear negotiation that lacks the clarity to define the term. *Phillips*, 415 F.3d at 1317 (prosecution history often unclear because it is a negotiation between the patentee and the examiner).

Whirlpool's citations of the specification also do not persuade the Court because they seek to import limitations from the specification into the claims. Whirlpool seeks to require the tubes to come from the "water tank" and not merely a "water source," but the claims do not include a limitation of a "water tank." ('820 patent, 11:45-12:5, 12:40-13:4, 13:6-27). It is the language of the claims where the Court's focus must remain. *Interactive Gift Express, Inc.* 256 F.3d at 1331. As such, the fact that the specification describes the tube as emanating from a water tank is immaterial.

At the *Markman* hearing, Whirlpool relied extensively on the fact that the description in the specification of the dispenser tube used the words "the present invention," which the caselaw suggests make it more likely that the claim will be limited to that meaning. *See Honeywell Int'l, Inc. v. ITT Indus., Inc.*, 452 F.3d 1312, 1318 (Fed. Cir. 2006); *Telecordia Tech., Inc., v. Cisco Sys., Inc.*, 612 F.3d 1365, 1374 (Fed. Cir. 2010). The Court recognizes the force of that caselaw, but finds that it is inapplicable here because two elements of the specification make clear that, despite its use of the language "the present invention," the specification is referring to a preferred embodiment.

First, the section of the patent that Whirlpool cites is titled "Best Mode for Carrying Out the Invention" and introduces itself by stating that "hereinafter, preferred embodiments of a refrigerator according to the present invention will be described in detail with reference to the accompanying drawings." ('820 patent, 5:32-40). As such, even if the subsequent language uses

the terms “the present invention,” the language must be read as describing a preferred embodiment.

Second, even the language that uses the term “the present invention,” makes clear that it is describing that invention only with reference to a particular preferred embodiment in Figure 6.

The language states:

Next, the structure for supplying water to the dispenser and the icemaker, according to the present invention will be described *with reference to Fig. 6.*

(‘820 patent, 8:3-5) (emphasis added). As such, the patentee was not describing the entire invention, but a particular embodiment. To import the requirement that “[t]he water tank **56** is connected to the dispenser **29** through the dispenser tube **58** to supply the water to the dispenser **29**” would improperly import limitations from the specification into the claims. *See Phillips v. AWH Corp.*, 415 F.3d 1303, 1320, 1323 (Fed. Cir. 2005) (it is improper to import the limitations of the specification into the claims).

The Court is also unconvinced that branching lines could not be “different.” The portion of the specification cited by Whirlpool is completely unprobative on the issue. (*See* ‘820 patent, 8:10-17). Further, while Whirlpool is correct that “different” could mean a difference in color, the concern that “separate” would read out branching tubes is a greater evil. Indeed, the context of the claim term reduces that possible error: the claim term states that “the dispenser tube being different than the ice maker tube.” This context makes clear that they are two different “tubes,” not the same tube, with two different colors.¹⁰ Consequently, the Court finds that the term does not require construction and should be construed in line with its plain meaning.

¹⁰ The Court does not understand how two tubes could be the same tube and be two different colors. As such, Whirlpool’s argument does not logically support its position.

III. Conclusion

For the foregoing reasons, the Court construes

- (1) “proximate to” to mean “very near”;
- (2) determines that “a damper configured to regulate air flow, from the ice compartment to the refrigerating compartment, through an opening in the wall of the ice compartment” does not require construction;
- (3) determines that “damper is configured to enable regulation of a temperature associated with the refrigerating compartment, through the opening in the wall of the ice compartment” does not require construction;
- (4) construes “ice transportation mechanism located within the ice compartment configured to promote the movement of ice stored within the ice compartment through an outlet defined in the ice compartment” to mean “rotating screw wires (or an equivalent structure) that move the ice stored in the ice compartment through an outlet of the ice compartment”;
- (5) construes “ice transportation mechanism is configured to, when the first door is in the closed position and the ice discharge duct is opened, transport ice stored within the ice compartment to the dispenser through the first and second portions of the ice discharge duct” to mean “rotating screw wires (or an equivalent structure) that, when the first door is in the closed position and the ice discharge duct is opened, transport the ice stored within the ice compartment to the dispenser through the first and second portions of the ice discharge duct”;

- (6) determines that “wherein the ice discharge duct is selectively opened and closed such that ice can be transferred to the dispenser positioned on the first door” does not require construction;
- (7) determines that “the ice discharge duct is selectively opened and closed independent of the movement of the first door” does not require construction;
- (8) determines that “dispenser tube configured to guide liquid water to the dispenser” does not require construction; and
- (9) determines that “dispenser tube being different than the ice maker tube” does not require construction.

Dated: April 25, 2011

/s/ Garrett E. Brown
GARRETT E. BROWN, JR., U.S.D.J.